

"Slip-On" Bushing Current Transformer Kits
KA712L1S, KA712L2S, KA712L3S, and KA712L5S
Installation Instructions and Technical Data

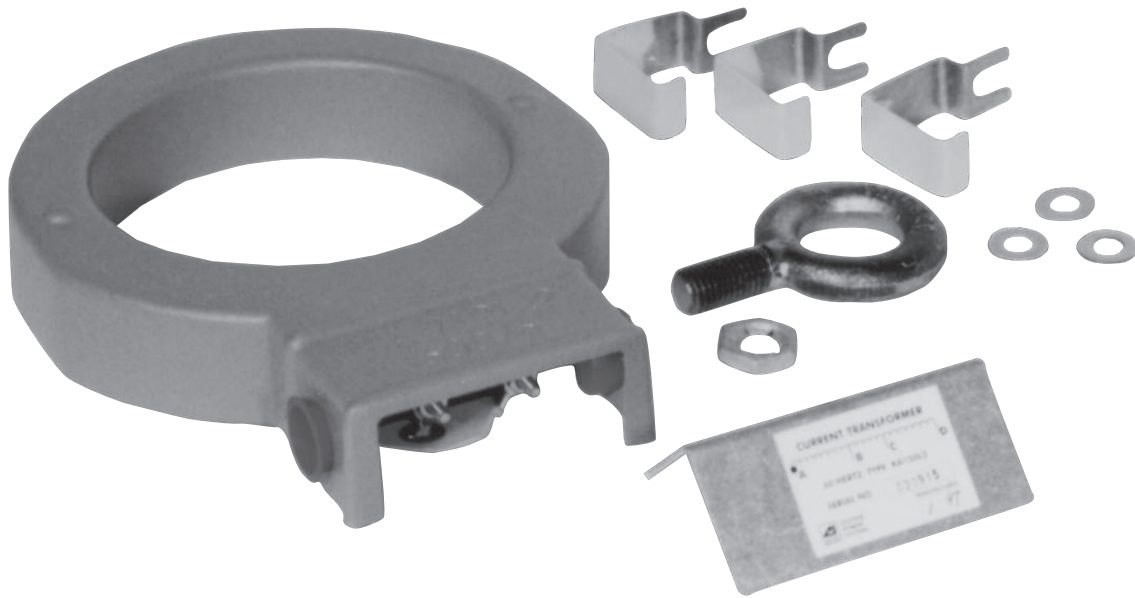

DISCLAIMER OF WARRANTIES AND LIMITATION OF LIABILITY

The information, recommendations, descriptions and safety notations in this document are based on Eaton Corporation's ("Eaton") experience and judgment and may not cover all contingencies. If further information is required, an Eaton sales office should be consulted. Sale of the product shown in this literature is subject to the terms and conditions outlined in appropriate Eaton selling policies or other contractual agreement between Eaton and the purchaser.

THERE ARE NO UNDERSTANDINGS, AGREEMENTS, WARRANTIES, EXPRESSED OR IMPLIED, INCLUDING WARRANTIES OF FITNESS FOR A PARTICULAR PURPOSE OR MERCHANTABILITY, OTHER THAN THOSE SPECIFICALLY SET OUT IN ANY EXISTING CONTRACT BETWEEN THE PARTIES. ANY SUCH CONTRACT STATES THE ENTIRE OBLIGATION OF EATON. THE CONTENTS OF THIS DOCUMENT SHALL NOT BECOME PART OF OR MODIFY ANY CONTRACT BETWEEN THE PARTIES.

In no event will Eaton be responsible to the purchaser or user in contract, in tort (including negligence), strict liability or otherwise for any special, indirect, incidental or consequential damage or loss whatsoever, including but not limited to damage or loss of use of equipment, plant or power system, cost of capital, loss of power, additional expenses in the use of existing power facilities, or claims against the purchaser or user by its customers resulting from the use of the information, recommendations and descriptions contained herein. The information contained in this manual is subject to change without notice.

Contents

DISCLAIMER OF WARRANTIES AND LIMITATION OF LIABILITY	ii
SAFETY FOR LIFE	iv
SAFETY INFORMATION	iv
Safety instructions	iv
PRODUCT INFORMATION	1
Introduction	1
Read this manual first	1
Additional information	1
Acceptance and initial inspection	1
Handling and storage	1
Standards	1
Quality standards	1
Description	2
INSTALLATION	3
Disassembly instructions	3
Connections	4
DIMENSIONS	4
ELECTRICAL DATA AND CHARACTERISTICS	4
Multi-Ratio 450:5	4
Multi-Ratio 450:5	4
Correction curves	5
CT excitation curves	7



Safety for life



Eaton meets or exceeds all applicable industry standards relating to product safety in its Cooper Power™ series products. We actively promote safe practices in the use and maintenance of our products through our service literature, instructional training programs, and the continuous efforts of all Eaton employees involved in product design, manufacture, marketing, and service.

We strongly urge that you always follow all locally approved safety procedures and safety instructions when working around high voltage lines and equipment, and support our “Safety For Life” mission.

Safety information

The instructions in this manual are not intended as a substitute for proper training or adequate experience in the safe operation of the equipment described. Only competent technicians who are familiar with this equipment should install, operate, and service it.

A competent technician has these qualifications:

- Is thoroughly familiar with these instructions.
- Is trained in industry-accepted high and low-voltage safe operating practices and procedures.
- Is trained and authorized to energize, de-energize, clear, and ground power distribution equipment.
- Is trained in the care and use of protective equipment such as arc flash clothing, safety glasses, face shield, hard hat, rubber gloves, clampstick, hotstick, etc.

Following is important safety information. For safe installation and operation of this equipment, be sure to read and understand all cautions and warnings.

Hazard Statement Definitions

This manual may contain four types of hazard statements:

DANGER

Indicates an imminently hazardous situation which, if not avoided, will result in death or serious injury.

WARNING

Indicates a potentially hazardous situation which, if not avoided, could result in death or serious injury.

CAUTION

Indicates a potentially hazardous situation which, if not avoided, may result in minor or moderate injury.

CAUTION

Indicates a potentially hazardous situation which, if not avoided, may result in equipment damage only.

Safety instructions

Following are general caution and warning statements that apply to this equipment. Additional statements, related to specific tasks and procedures, are located throughout the manual.

DANGER

Hazardous voltage. Contact with hazardous voltage will cause death or severe personal injury. Follow all locally approved safety procedures when working around high- and low-voltage lines and equipment.

G103.3

WARNING

Before installing, operating, maintaining, or testing this equipment, carefully read and understand the contents of this manual. Improper operation, handling or maintenance can result in death, severe personal injury, and equipment damage.

G101.0

WARNING

This equipment is not intended to protect human life. Follow all locally approved procedures and safety practices when installing or operating this equipment. Failure to comply can result in death, severe personal injury and equipment damage.

G102.1

WARNING

Power distribution and transmission equipment must be properly selected for the intended application. It must be installed and serviced by competent personnel who have been trained and understand proper safety procedures. These instructions are written for such personnel and are not a substitute for adequate training and experience in safety procedures. Failure to properly select, install or maintain power distribution and transmission equipment can result in death, severe personal injury, and equipment damage.

G122.2

Product information

Introduction

Service Information MN280037EN provides installation instructions and technical data for Eaton’s Cooper Power™ series KA712L1S, KA712L2S, KA712L3S, and KA712L5S “Slip-On” bushing current transformer (CT) kits.

Note: Users intending to install the “Slip-On” bushing CT kit on all three phases of a three-phase recloser must order three kits (one kit per phase).

Note: If desired, connect set of 3 bushing CTs for kit KA712L2S with wiring kit KA895RS. Contact your Eaton representative for additional information.

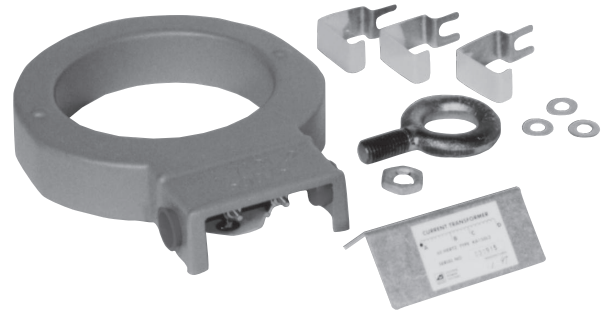

Figure 1. Multi-ratio, “Slip-On” CT kit

Read this manual first

Read and understand the contents of this manual and follow all locally approved procedures and safety practices before installing or operating this equipment.

Additional information

These instructions cannot cover all details or variations in the equipment, procedures, or process described nor provide directions for meeting every possible contingency during installation, operation, or maintenance. For additional information, contact your Eaton representative.

In addition to this manual, also refer to Table 3 for the appropriate service manual for the model being equipped with the kit.

Acceptance and initial inspection

Each “Slip-On” bushing CT kit is in good condition at the factory and when accepted by the carrier for shipment.

Upon receipt, inspect the carton for signs of damage. Unpack the kit(s) and inspect it thoroughly for damage incurred during shipment. If damage is discovered, file a claim with the carrier immediately.

Handling and storage

Be careful during handling and storage of the kit to minimize the possibility of damage. If the kit is to be stored for any length of time prior to installation, provide a clean, dry storage area.

Standards

Eaton’s reclosers are designed and tested in accordance with ANSI® standards C37.60 and C37.85 and ANSI® guideline C37.61.

Quality standards

ISO 9001 Certified Quality Management System

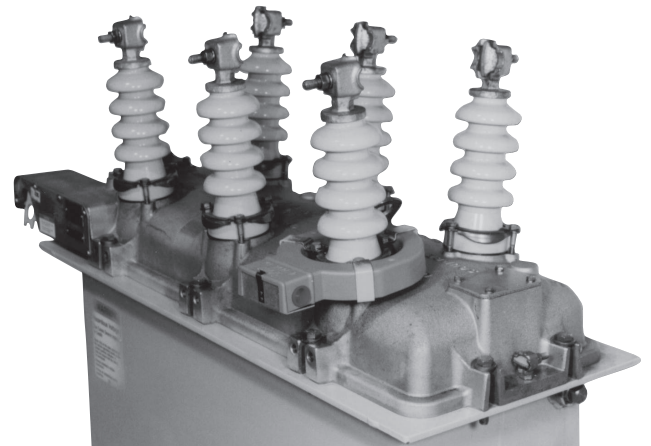

Figure 2. CT properly installed on bushing

“Slip-On” Bushing Current Transformer Kits KA712L1S, KA712L2S, KA712L3S, and KA712L5S

Description

The slip-on, multi-ratio bushing current transformers are especially designed by Eaton for use with numerous Cooper Power series single-and three-phase distribution switchgear for load metering at the equipment location. The CT is available only as a kit for field installation. The kit consists of the epoxy-encapsulated, current-transformer assembly, cover assembly/nameplate, three clamps and washers for attaching the CT to the bushing clamping bolts of the switchgear unit, and an eyebolt lifting lug with a palnut, if applicable (Figure 1 and Table 1). An eyebolt and palnut are supplied with kits KA712L1S, KA712L3S, and KA712L5S for replacement of the standard fabricated lifting lug, to allow additional clearance for the CT on the head. Refer to Table 2 for the appropriate application of each kit.

Table 1. Kit Parts

Part Description	KA712L1S	KA712L2S	KA712L3S	KA712L5S
Current transformer assembly (CT)	1	1	1	1
Clover assembly/nameplate	1	1	1	1
Clamp	3	3	3	1 short, 2 long
Washer	3	3	3	3
Eyebolt	1	-	1	1
Palnut	1	-	1	1

Note: If desired, connect set of 3 BCTs for kit KA712L2S with wiring kit KA895RS. Contact your Eaton representative for additional information.

Table 3. Service Information for Additional Instructions

Product Type	Model	Service Information
Single-Phase Reclosers	E, 4E, L	MN280051EN
	D, DV	MN280030EN
	VXE	S280-16-1
	V4L, V4E	MN280051EN
Three-Phase Reclosers	3H	S280-10-4
	6H, V6H	MN280023EN
	R	MN280026EN
	RE	S280-40-3
	RX	S280-30-8
	RXE	S280-40-7
	RV	S280-30-4
	RC Serial No. 4111 and after	S280-30-9
	RVE	S280-40-5
	W, WV27, WV38X, VW, VVV27, VVV38X	MN280021EN
WE, WVE27, WVE38X, VWE, VVVE27, VVVE38X	MN280060EN	
Sectionalizers	GN3	S270-10-8
	GN3E, GN3VE	MN270001EN
	GV Serial No. 1302 and above	S270-20-2
	GV Serial No. 2265 and above	S270-20-3
	GW	S270-20-3
	GWC	S270-21-1
Switches	F	S260-50-1
	TSC	S260-20-10
	VRV	S260-20-6

Table 2. Kit Description and Application

Catalog Number	Kit Description	Single-Phase Reclosers	Three-Phase Reclosers	Sectionalizers	Switches
KA712L1S	Multi-ratio (450:5 ratio) “Slip-on” Bushing CT	E, 4E, L, V4L, V4E, VXE		GN3, GV*, GN3E, GN3VE	TSC, VRV
KA712L2S (see Note)	Multi-ratio (600:5 ratio) “Slip-on” Bushing CT	DV	R**, RE, RX, RXE, RV, RVE, W, WE, WV27, WV38X, WVE27, WVE38X, VW, VWE, VVV27, VVV38X, VVVE27, VVVE38X, 3H, 6H, V6H	GW, GWC	F
KA712L3S	Multi-ratio (600:5 ratio) “Slip-on” Bushing CT	D	-	-	-
KA712L5S	Multi-ratio (600:5 ratio) “Slip-on” Bushing CT	VXE	-	-	-
Eyebolt	1	-	1	1	

* Not applicable above Serial No. 1000.

** Not applicable below Serial No. 3733.

*** Installing this kit on all three phases of a three-phase recloser requires three kits (one kit for each phase).

Installation

Disassembly instructions

Refer to the appropriate service information instruction manual for the step-by-step procedures to remove the recloser from service. Refer to Table 3 for specific service manual information.

IMPORTANT

Before beginning the disassembly process, ensure the recloser is in the open position.

WARNING

Hazardous voltage. De-energize the switchgear before installing this kit. Follow all locally approved safety practices and procedures when working around high voltage lines and equipment. Failure to comply can result in contact with high voltage, which will cause death or severe personal injury.

T232.3

CAUTION

Follow all locally approved safety practices when lifting and mounting the equipment. Use the tapped lifting provisions provided. Lift the load smoothly and do not allow the load to shift. Improper lifting can result in equipment damage.

G126.0

To begin the installation process:

1. Bypass, trip, and de-energize the recloser.
2. Disconnect the lead wires from the bushings
3. Carefully transport the unit to a suitable service facility.

Note: If the recloser is equipped with extra-creepage busings, it may be necessary to remove the bushings when installing the “slip-on” bushing CT. This may require the tank to be dropped.

CAUTION

Equipment damage. Refer to the specific switchgear unit maintenance manual for tanking/untanking procedures and related instructions. Failure to follow these instructions could result in equipment damage or personal injury.

T238.0

4. For kit KA712L2, skip Step 4. Continue with Step 5. This step is only applicable to kits KA712L1, KA712L3, and KA712L5:

Remove the fabricated lifting lug from the head and substitute the eyebolt lug, locking it in position with the palnut.

5. Slip the CT over the top of the bushing and position it at the base of the bushing with the terminal box positioned outboard and the black-epoxy-side down.

6. Loosen the three bushing clamping bolts and attach the CT by slipping the slotted end of the clamp under the lockwasher while clipping the other end to the CT (Figure 1). Position the clamp so the top surface of the CT is at the level of the bushing clamps in order to maintain the BIL rating of the switch gear unit.

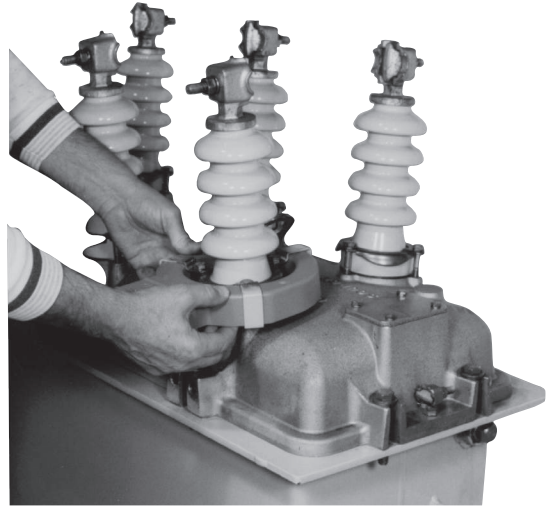

Figure 3. Mounting clamp is clipped to CT assembly and attached under bushing clamping bolt

For kit KA712L5, position the shorter clamp closest to the eyebolt lifting lug and position the two longer clamps towards the outside of the head casting.

Note: Make sure the insulation coating on the CT end of the clamp is intact and undamaged. If bare metal on this end of the bracket touches the head, a “shorted-turn” effect is produced which affects the CT output and accuracy.

CAUTION

Equipment damage. Do not attempt to mount the bushing CT by drilling or tapping into the CT rink assembly. Perforation of the CT ring can damage the internal windings and cause ingress of moisture. Failure to comply can result in equipment damage and misoperation.

T298.0

7. Retighten all three bushing clamping bolts evenly, a little at a time. Refer to Table 3 for the appropriate bushing bolt torque specifications.
8. Snap the cover assembly over the terminal connectors of the CT housing. A properly installed CT kit is shown on the cover page.

“Slip-On” Bushing Current Transformer Kits KA712L1S, KA712L2S, KA712L3S, and KA712L5S

Connections

Connections to the CT are made in the junction box. Terminal connections for the various ratios are shown on the inside of the junction-box cover. The junction box has 7/8 in. diameter holes at either end which will accommodate standard 1/2 in. conduit fittings or Pyle-National, DS series cable-sealing grips (if rubber-covered cable is used for the meter leads).

IMPORTANT

Do not remove the shorting lead across CT terminals until external connections are made.

Dimensions

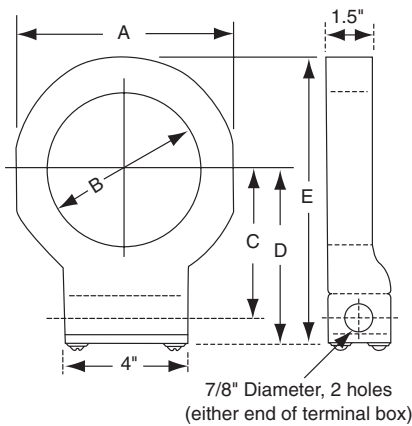

Dimension	Multi-Ratio 450.5	Multi-Ratio 600.5
A	6 15/16	7 3/4
B	4 3/4	5 1/2
C	4 7/8	5 9/32
D	5 5/8	6 1/16
E	9 1/8	9 15/16

Figure 4. Dimensions

Table 4. Bushing Bolt Torque Specifications

Model	Bushing Bolts Applied Torque in Ft. • Lbs.
3Ht	6-10
GN3E, GN3, GN3VE, 6H, V6H	6-10
GV	6-10
L, E, 4E, V4L, V4E, VXE-15, VXE-27	6-10
VWE, VWVE27, VWVE38X, R, RE, RX, RXE, WV27, WV38X GWC, GW, RV, RVE, W, WE, WVE27, WVE38X, VRV, VW, VWV27, VWV38X	10-15

Electrical Data and Characteristics

The current transformers have four taps to provide the following ratios within a $\pm 5\%$ accuracy for conventional metering.

Multi-Ratio 450:5

Catalog Number: KA712L1S

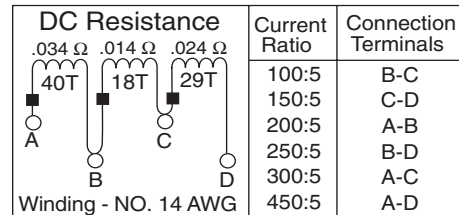

Figure 5. Current ratio and connection terminals for KA712L1S

Multi-Ratio 450:5

Catalog Numbers: KA712L2S, KA712L3S, and KA712L5S

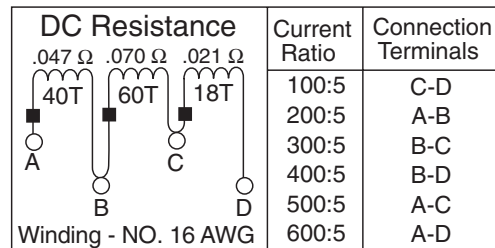

Figure 6. Current ratios and connection terminals for KA712L2S, KA712L3S, and KA712L5S

All CTs can carry 150% of rated secondary current continuously.

Note: Physical construction requires an irregular turns ratio for some windings to provide $\pm 5\%$ accuracy at all ratios.

“Slip-On” Bushing Current Transformer Kits KA712L1S, KA712L2S, KA712L3S, and KA712L5S

Correction curves

If accuracies greater than the nominal $\pm 5\%$ are desired, typical correction curves for the CTs at all ratios are shown in Figures 4 and 5. The correction curves are drawn for three different transformer burdens:

Curve 1: 0.4 Ω impedance

Curve 2: 0.21 Ω impedance

Curve 3: 0.1 Ω impedance

The 0.21 Ω burden represents the impedance of a Sangamo Type ADS meter with a 5 A scale and instantaneous elements. The 0.4 Ω burden represents the impedance of this same meter with a total of 40 feet of No. 16 AWG conductor leads (meter 20 feet from CT). The 0.1 Ω burden curves are included to allow for interpolation for other meter loads.

How to use correction curves

Assume a total burden of 0.4 Ω (Curve 1) with the meter connected to KA712L1S for a 100:5 A ratio, and reading 3 A. From the appropriate curve the correction factor is 1.024; the corrected secondary current is $3/0 \times 1.024 = 3.072$ A; and the actual primary current is $3.072 \times 100/5 = 61.4$ A.

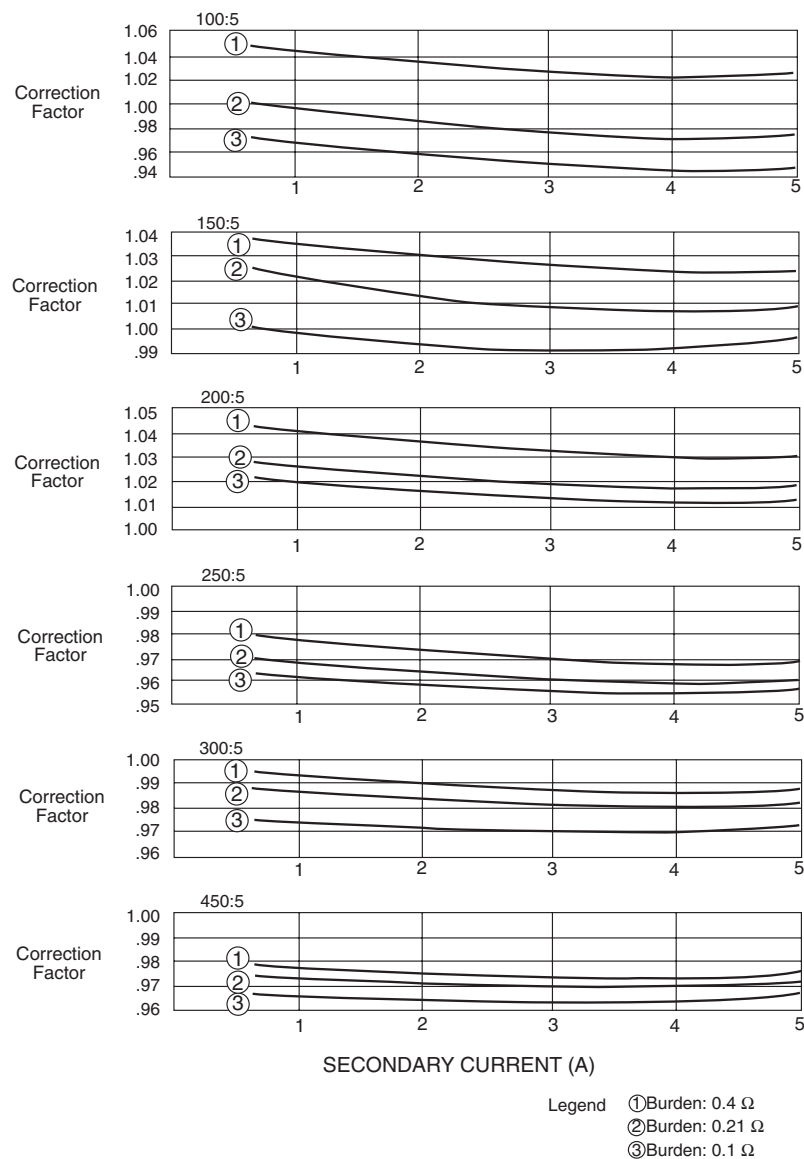

Figure 7. Correction curves for 450:5 multi-ratio bushing current transformer, Catalog No. KA712L1S

“Slip-On” Bushing Current Transformer Kits KA712L1S, KA712L2S, KA712L3S, and KA712L5S

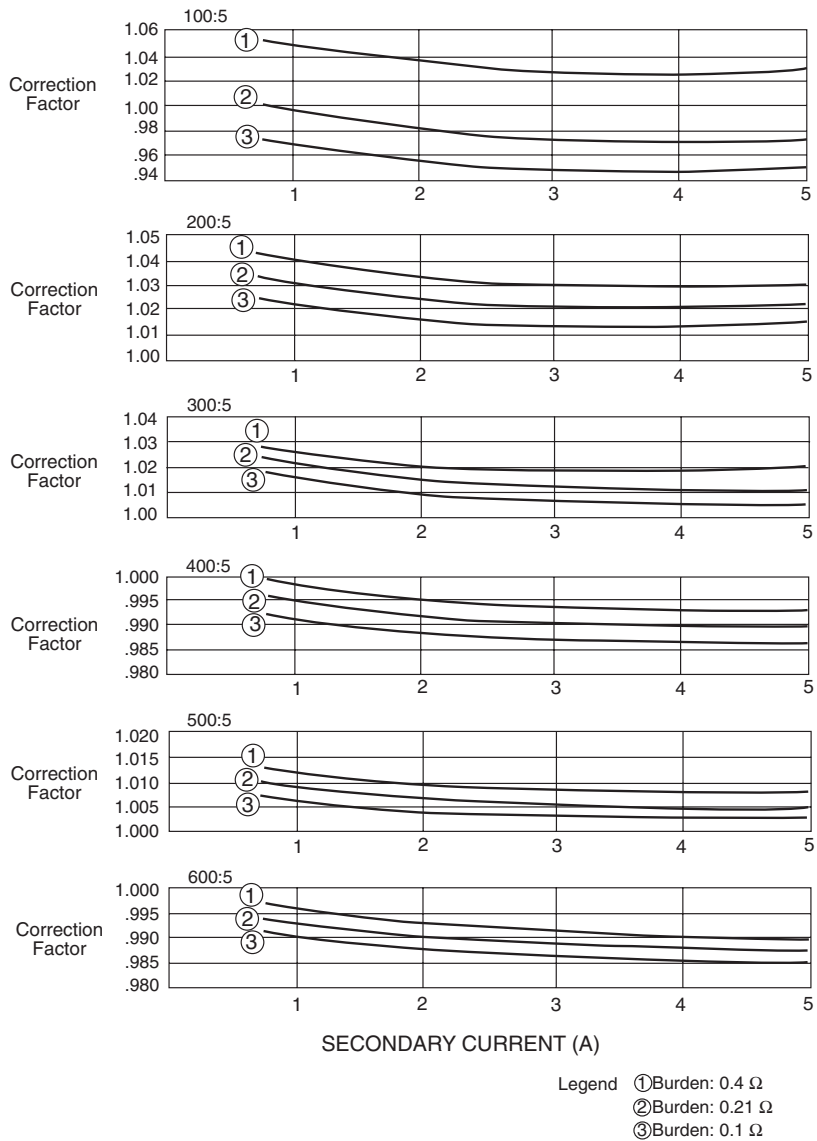

Figure 8. Correction curves for 600:5 multi-ratio bushing current transformer, Catalog Numbers KA712L2S, KA712L3S, and KA712L5S

CT excitation curves

For specific applications at burdens different from those plotted on the correction curves, the secondary excitation curves can be used. These curves plot the CT secondary voltage versus the exciting current of the CTs for all ratios. For a given secondary load the secondary voltage is the product of the secondary impedance and the actual secondary current. Using this voltage, the secondary exciting current can be determined from the appropriate curve. The total secondary current is the sum of the meter reading and the exciting current. Multiplying this total secondary current by the actual turns ratio of the CT winding will give the actual primary current.

How to use the excitation curves

Using the same assumptions as in the example for the correction curves; namely CT KA712L1S, 100:5 A tap, 0.4 Ω burden and 3 A meter reading, the secondary voltage is $3 \times 0.4 = 1.2$ V. From the curve, this voltage produces an exciting current of 0.41 A, and the total secondary current will be $3 + 0.41 = 3.41$ A. Multiply this by the turns, $3.41 \times 18 = 61.38$ the actual primary current.

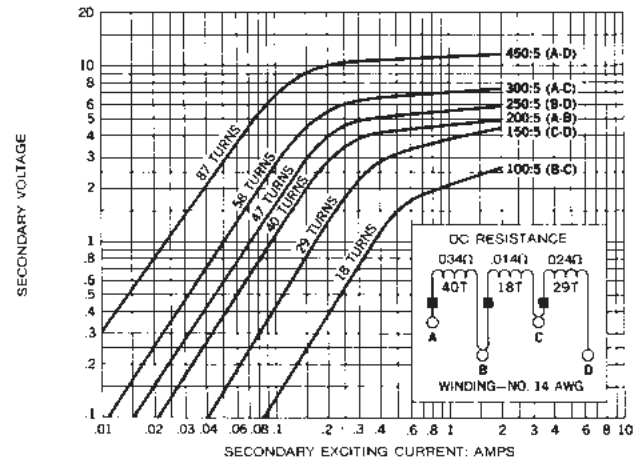

Figure 9. Typical secondary excitation curves for 450:5 Multi-ratio “Slip-on” Bushing Current Transformer, Catalog No. KA712L1S.

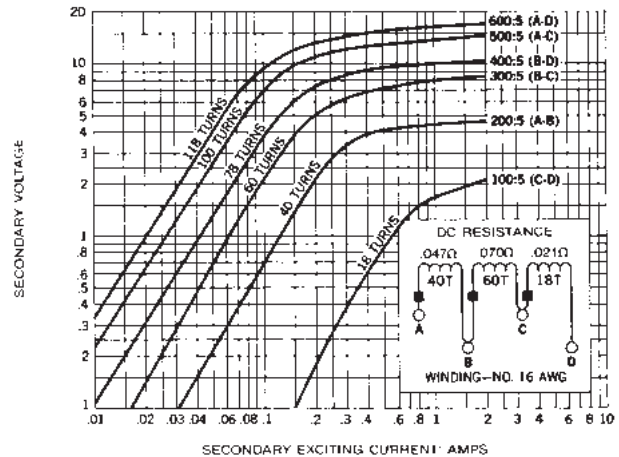

Figure 10. Typical secondary excitation curves for 600:5 Multi-ratio “Slip-on” Bushing Current Transformer, Catalog Numbers KA712L2S, KA712L3S, and KA712L5S



Eaton
1000 Eaton Boulevard
Cleveland, OH 44122
United States
Eaton.com

Eaton's Power Systems Division
2300 Badger Drive
Waukesha, WI 53188
United States
Eaton.com/cooperpowerseries

©2017 Eaton
All Rights Reserved
Printed in USA
Publication No. MN280037EN
KA2048-187 Rev: 05)

Eaton is a registered trademark.

All trademarks are property
of their respective owners.

For Eaton's Cooper Power series product
information, call 1-877-277-4636 or visit:
www.eaton.com/cooperpowerseries.