

KA716L7001 adjustable control valve kit for Types L, E, 4E, V4E,  
and V4L reclosers installation and adjustment instructions



*Powering Business Worldwide*

## **DISCLAIMER OF WARRANTIES AND LIMITATION OF LIABILITY**

The information, recommendations, descriptions and safety notations in this document are based on Eaton Corporation's ("Eaton") experience and judgment and may not cover all contingencies. If further information is required, an Eaton sales office should be consulted. Sale of the product shown in this literature is subject to the terms and conditions outlined in appropriate Eaton selling policies or other contractual agreement between Eaton and the purchaser.

THERE ARE NO UNDERSTANDINGS, AGREEMENTS, WARRANTIES, EXPRESSED OR IMPLIED, INCLUDING WARRANTIES OF FITNESS FOR A PARTICULAR PURPOSE OR MERCHANTABILITY, OTHER THAN THOSE SPECIFICALLY SET OUT IN ANY EXISTING CONTRACT BETWEEN THE PARTIES. ANY SUCH CONTRACT STATES THE ENTIRE OBLIGATION OF EATON. THE CONTENTS OF THIS DOCUMENT SHALL NOT BECOME PART OF OR MODIFY ANY CONTRACT BETWEEN THE PARTIES.

In no event will Eaton be responsible to the purchaser or user in contract, in tort (including negligence), strict liability or otherwise for any special, indirect, incidental or consequential damage or loss whatsoever, including but not limited to damage or loss of use of equipment, plant or power system, cost of capital, loss of power, additional expenses in the use of existing power facilities, or claims against the purchaser or user by its customers resulting from the use of the information, recommendations and descriptions contained herein. The information contained in this manual is subject to change without notice.

# Contents

## SAFETY INFORMATION

Safety instructions . . . . .	iv
-------------------------------	----

## PRODUCT INFORMATION

Introduction . . . . .	1
Acceptance and initial inspection . . . . .	1
Handling and storage . . . . .	1
ANSI standards . . . . .	1
Quality standards . . . . .	1
Description . . . . .	1

## INSTALLATION PROCEDURE . . . . . 2

### CONTROL VALVE ADJUSTMENT PROCEDURE

B and D time current curve settings . . . . .	3
C time current curve setting . . . . .	3
Pump piston . . . . .	3
Piston adjustment . . . . .	3
Trip linkage . . . . .	4
Trip point . . . . .	5

### TESTING

High-potential withstand test . . . . .	6
Contact operation test . . . . .	6
Recommended test parameters . . . . .	7
Testing TCCs . . . . .	7

### KIT PARTS LIST . . . . . 8



## Safety for life



Eaton meets or exceeds all applicable industry standards relating to product safety in its Cooper Power™ series products. We actively promote safe practices in the use and maintenance of our products through our service literature, instructional training programs, and the continuous efforts of all Eaton employees involved in product design, manufacture, marketing, and service.

We strongly urge that you always follow all locally approved safety procedures and safety instructions when working around high voltage lines and equipment, and support our “Safety For Life” mission.

## Safety information

The instructions in this manual are not intended as a substitute for proper training or adequate experience in the safe operation of the equipment described. Only competent technicians who are familiar with this equipment should install, operate, and service it.

A competent technician has these qualifications:

- Is thoroughly familiar with these instructions.
- Is trained in industry-accepted high and low-voltage safe operating practices and procedures.
- Is trained and authorized to energize, de-energize, clear, and ground power distribution equipment.
- Is trained in the care and use of protective equipment such as arc flash clothing, safety glasses, face shield, hard hat, rubber gloves, clampstick, hotstick, etc.

Following is important safety information. For safe installation and operation of this equipment, be sure to read and understand all cautions and warnings.

### Hazard Statement Definitions

This manual may contain four types of hazard statements:

#### DANGER

Indicates an imminently hazardous situation which, if not avoided, will result in death or serious injury.

#### WARNING

Indicates a potentially hazardous situation which, if not avoided, could result in death or serious injury.

#### CAUTION

Indicates a potentially hazardous situation which, if not avoided, may result in minor or moderate injury.

#### CAUTION

Indicates a potentially hazardous situation which, if not avoided, may result in equipment damage only.

### Safety instructions

Following are general caution and warning statements that apply to this equipment. Additional statements, related to specific tasks and procedures, are located throughout the manual.

#### DANGER

**Hazardous voltage. Contact with hazardous voltage will cause death or severe personal injury. Follow all locally approved safety procedures when working around high- and low-voltage lines and equipment.**

G103.3

#### WARNING

**Before installing, operating, maintaining, or testing this equipment, carefully read and understand the contents of this manual. Improper operation, handling or maintenance can result in death, severe personal injury, and equipment damage.**

G101.0

#### WARNING

**This equipment is not intended to protect human life. Follow all locally approved procedures and safety practices when installing or operating this equipment. Failure to comply can result in death, severe personal injury and equipment damage.**

G102.1

#### WARNING

**Power distribution and transmission equipment must be properly selected for the intended application. It must be installed and serviced by competent personnel who have been trained and understand proper safety procedures. These instructions are written for such personnel and are not a substitute for adequate training and experience in safety procedures. Failure to properly select, install or maintain power distribution and transmission equipment can result in death, severe personal injury, and equipment damage.**

G122.2

## Product information

### Introduction

*Service Information MN280034EN* provides installation instructions for the adjustable control valve assembly for the B, C, and D time current curves on Eaton's Cooper Power™ series L, E, 4E, V4L, and V4E hydraulic reclosers. Carefully read and understand the contents of this manual before installing this kit.

The information contained in this manual is organized into the following major categories: *Safety Information, Product Information, Installation Procedure, Adjustment Procedure, Testing, and Kit Parts List.*

### Read this manual first

Read and understand the contents of this manual and follow all locally approved procedures and safety practices before installing or operating this equipment.

### Additional information

These instructions cannot cover all details or variations in the equipment, procedures, or process described nor provide directions for meeting every possible contingency during installation, operation, or maintenance. When additional information is desired to satisfy a problem not covered sufficiently for the user's purpose, please contact your Eaton representative.

### Acceptance and initial inspection

Each adjustable control valve kit is in good condition at the factory and when accepted by the carrier for shipment.

Upon receipt, inspect the carton for signs of damage. Unpack the kit(s) and inspect it thoroughly for damage incurred during shipment. If damage is discovered, file a claim with the carrier immediately.

### Handling and storage

Use care during handling and storage of the kit to minimize the possibility of damage. If the kit is to be stored for any length of time prior to installation, provide a clean, dry storage area.

### Standards

Eaton's reclosers are designed and tested in accordance with ANSI® standards C37.60 and C37.85 and ANSI® guideline C37.61.

### Quality standards

ISO 9001 Certified Quality Management System

### Description

This kit includes instructions for adjustable control valves for the B, C, and D time current curves. The adjustable control valve can be used to replace the high pressure control valve in Types L, E, (Serial Number 52000 and above) 4E, V4L, and V4E reclosers.

The adjustable control valve allows for improved adjustment of the timing curve by allowing adjustment of the point at which the high-pressure control valve opens.

---

## IMPORTANT

---

Indicates a potentially hazardous situation which, if not avoided, may result in equipment damage only.

---

**Table 1. Ordering Information**

Description	Catalog Number
Adjustable Control Valve Kit	KA716L7001

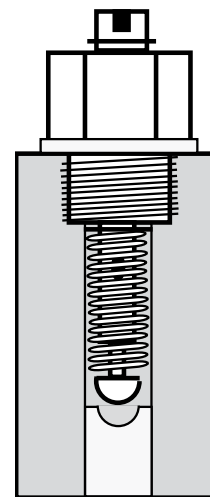

**Figure 1. Illustration of adjustable control valve kit assembled in solenoid casting.**

## Installation procedure

Refer to *Service Publication S280-25-5* for Type E Single-Phase Reclosers applicable to Serial Numbers 52000 and above, *S280-15-1* for Type L Single-Phase Reclosers, *S280-15-7* for Type V4L and V4E Single-Phase Reclosers, and *S280-25-4* for Type 4E reclosers for tear-down and rebuild information for these units.

### **⚠ WARNING**

**Hazardous voltage. De-energize the switchgear before installing this kit. Follow all locally approved safety practices and procedures when working around high voltage lines and equipment. Failure to comply can result in contact with high voltage which will cause death or severe personal injury.**

T232.3

### **⚠ WARNING**

**Hazardous voltage. Do not rely on the open position of the yellow operating handle; it does not ensure that the line has been de-energized. Always establish a visible disconnect. Failure to follow proper safety practices can result in contact with high voltage, which will cause death or severe personal injury.**

G116.0

### **CAUTION**

**Equipment damage. Keep work areas clean to prevent debris from accumulating on or in the hydraulic mechanism during disassembly and reassembly procedures. Failure to comply can result in hydraulic failure and recloser misoperation.**

T254.0

### **IMPORTANT**

Remove the recloser from service and transport it to a clean, suitably equipped service center prior to installing the new adjustable control valve kit.

When installing this kit, use a clean, lint-free cloth to prevent contamination of the hydraulic mechanism during valve replacement.

Figure 2 illustrates the kit installed in the solenoid frame casting.

### **⚠ CAUTION**

**Equipment damage. Refer to the specific switchgear unit maintenance manual for tanking/untanking procedures and related instructions. Failure to follow these instructions could result in equipment damage or personal injury.**

T238.0

To begin the installation process:

1. Bypass, trip, and de-energize the recloser, and remove the recloser from service.
2. Carefully transport the unit to a suitable service facility.

3. With the recloser in the open position, untank the recloser by loosening the head bolts and washers on the head casting. Carefully lift the head assembly out of the tank using the lifting lug(s).
4. Remove the control valve from the mechanism per the appropriate instructions in the unit's service manual as previously listed.
5. Install the new control valve per the appropriate instructions as listed in the unit's service manual.

The valve has five maximum full turns (from all the way out, to all the way in) to set the B, C, and D time-current curves on the adjustable control valves. Use a screwdriver to make a time-current curve adjustment (Figure 2).

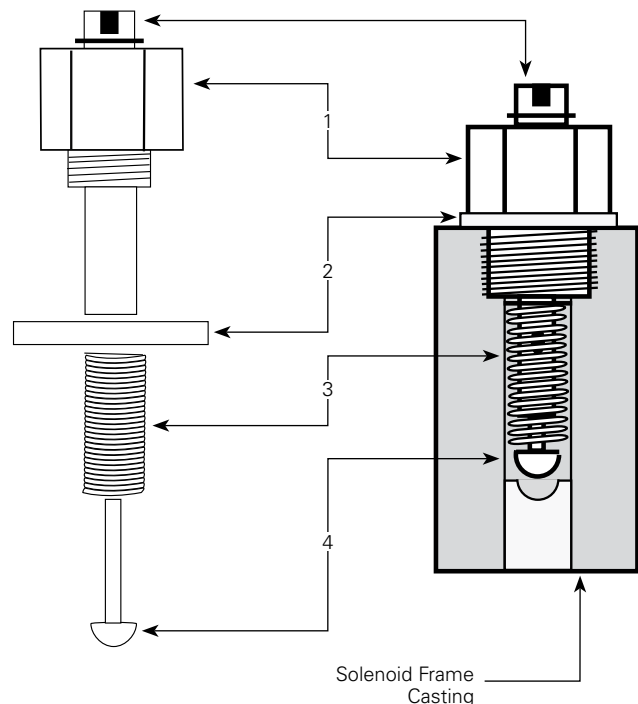

**Figure 2. Illustration of valve kit components assembled into casting. (Not drawn to scale). See Table 3 for part identification.**

### **IMPORTANT**

When testing the recloser at mid or high current levels and adjustment is required, adjust as follows:

- Screw the adjustment screw upward or counter-clockwise to increase the time.
- Screw the adjustment screw downward or clockwise to decrease the time.

Refer to **Recommended Test Parameters** in **Testing** section of this manual for additional information.

## Control valve adjustment procedure

### B and D time current curve settings

1. Gently turn the adjustment screw clockwise until it bottoms out.
2. Gently turn the adjustment screw counter-clockwise 2.5 turns to achieve the correct adjustment for the B and D adjustments.

### C time current curve setting

Turn the adjustable spring retainer clockwise and gently bottom it out to achieve C curve settings.

After replacing service parts or changing the operating sequence, verify the operation of the recloser. The pump piston shell and the trip linkage can be initially set by operating the recloser mechanism out of oil.

To verify the adjustments, use a suitable tester to apply the required test currents. The fine-tuning procedure begins with adjustment of the pump piston shell, as shown in Figures 3 and 4, to produce the correct number of fast operations. It concludes with adjustment of the trip linkage to produce the correct number of operations to lockout.

### Pump piston

The pump piston, part of the hydraulic circuit, moves down as the solenoid plunger moves up. Since piston size is critical to operation, an adjustable shell sets piston size. See Figure 4. Adjustment of the pump piston and pump piston shell is accomplished by turning (rotating) the piston either into the shell or out of the shell.

During its downward stroke, this piston pumps a measured charge of oil from under the piston itself. Turning the piston out of the piston shell causes the piston to pump less oil. Turning the piston into the piston shell causes the piston to pump more oil. With recloser in the open position, initially set the pump piston according to Figure 3.

### Piston adjustment

Adjustment of the pump piston shell must be done with a suitable tester. Refer to *Reference Data R280-90-2 Low Voltage AC Testing of Hydraulic Reclosers* for additional information. The tester should be adjusted to provide a minimum of four-times the continuous trip current of the recloser being tested. Use the following procedure to test the piston shell adjustment:

**Note:** Test Type E reclosers above Serial No. 52000 to the same voltages as the Type L recloser identified in *Reference Data R280-90-2*.

1. Move the yellow manual operating handle to the CLOSED position and wait at least three minutes for the trip piston to fully reset.

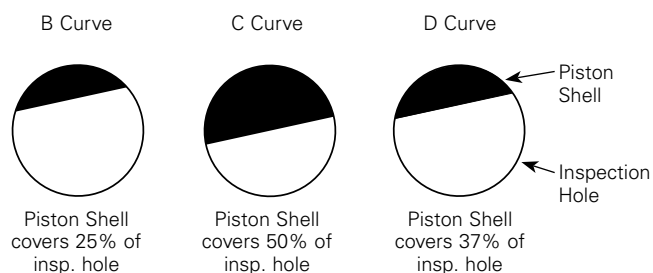

**Figure 3. Pump piston shell adjustment (approximate).**

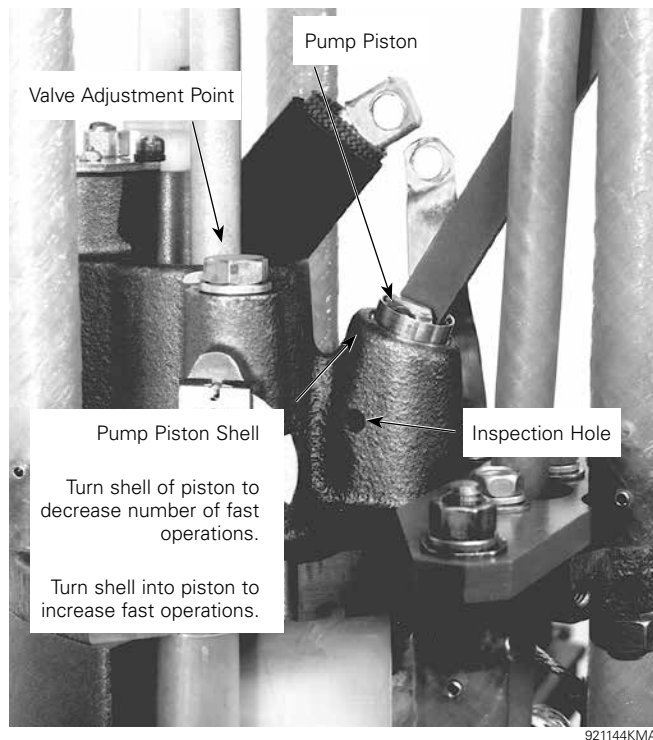

**Figure 4. Inspection hole, pump piston, pump piston shell, and adjustable valve.**

2. Operate the tester (per manufacturer's directions) to apply the required current through the recloser. Note the sequence and number of operations.

**Note:** During fast operations, the recloser contact will open almost immediately after test current is applied. During delayed operations, a noticeable delay will be observed before the recloser operates. When lockout occurs, the yellow manual operation handle will drop down. The trip times recorded for all fast operations should be almost identical

- The number of fast and delayed operations must match the data plate specifications and the settings selected by the assembly of the service kit parts. If the sequence does not match, check to see if the recloser is correctly configured. If the configuration is correct, the problem may be either a misadjusted pump piston or an oil leak.

**Note:** If the recloser operates too many or too few times to lockout, it will be necessary to adjust the trip linkage to achieve the correct number of operations to lockout. It may be necessary to re-adjust the piston shell and trip linkage several times to obtain the proper sequence and time characteristics.

- Inspect the upper coil gasket and replace if damaged or worn. Repeat the test.
- If the recloser is performing too many fast operations, turn (rotate) the piston shell counter-clockwise slightly (off the pump piston); refer to Figure 4. Repeat the test.
- If the recloser is performing too few fast operations, turn the piston shell clockwise slightly (onto the pump piston) as shown in Figure 4. Repeat the test.
- Continue to test and adjust the pump piston shell until the recloser performs the proper number of fast trip operations.

**Note:** If the adjustment of the pump piston shell will not provide proper operation, the piston shell may be worn. Replace the piston shell assembly and repeat the test and the adjustment procedure.

- If using a new piston assembly, after the adjustment is correctly set, stake the piston shell to prevent movement. Refer to Figure 7.
- If the total number of operations is not correct, test the trip point adjustment.

### Trip linkage

After adjusting the pump piston for the correct number of fast operations, adjust the trip linkage so the recloser will operate the correct number of times to lockout. Initial adjustment is performed by operating the solenoid out of oil.

**Note:** With the solenoid assembly removed from the tank, prevent damage to the mechanism by not allowing recloser to fast open.

- Firmly rest thumb in the groove under the eyelet of the yellow manual operating handle to prevent fast opening when the latch releases. With thumb in position manually close the recloser.
- Grasp trip piston assembly and lift until the recloser trips. Observe the roll pin that secures the trip piston to the trip piston adjuster assembly. Refer to Figures 5 and 6. Note the location of the roll pin relative to the trip adjuster stop (spacer) as shown in Figure 6.

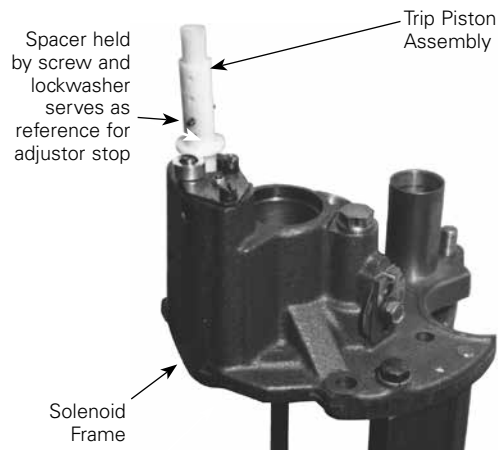

931168KMA

**Figure 5. Trip spacer.**

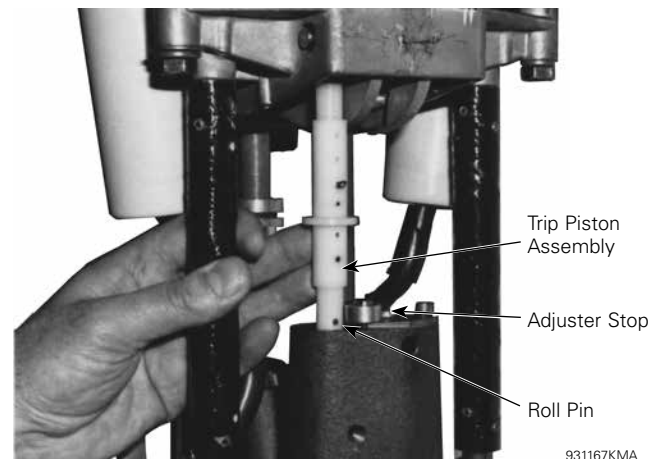

931167KMA

**Figure 6. Trip linkage adjustment.**

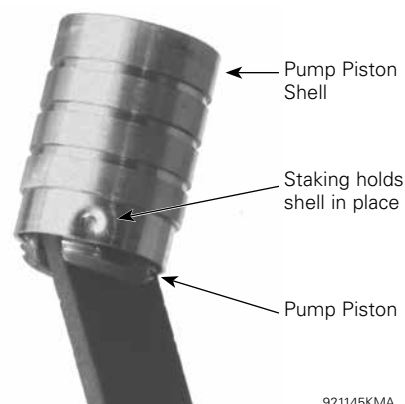

921145KMA

**Figure 7. Pump-piston shell adjusts length of piston.**

- If sequence is set for 0, 2, or 3 fast operations, the recloser should trip to lockout when the roll pin is even with the bottom of the trip adjuster stop.



- B. If sequence is set for 1 fast operation, the recloser should trip to lockout when the roll pin is about even with the top of the trip adjuster stop.
- C. If the recloser trips too soon (roll pin below desired height), turn the self-locking nuts counter-clockwise or away from head casting. Refer to Figure 8.
- D. If the recloser trips too late (roll pin above desired height), turn the self-locking nuts clockwise or toward the head casting.

**Note:** Be sure to maintain free play between the trip linkage mechanism and the two self-locking nuts. Loosen one nut one-half turn, to maintain proper free play, any time the assembly becomes tight. If free play is in question, make sure the adjustment is correct, tighten the bottom nut against the trip linkage mechanism, then back the nut off 1-1/2 turns.

- 3. Retank the recloser and test operation of the pump piston and trip point adjustment using a low voltage tester.

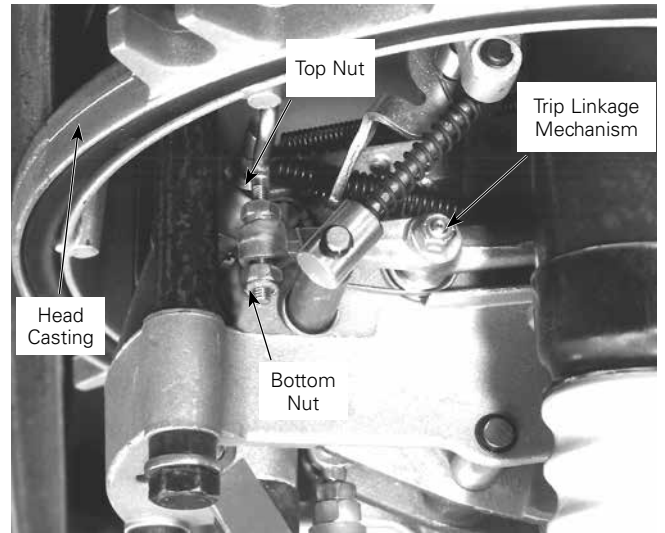

**Figure 8. Trip point adjustment.**

### Trip point

After the pump piston has been adjusted to perform the correct number of fast operations, the trip linkage must be adjusted so the recloser will operate the correct number of times to lockout.

- 1. Move the yellow manual operating handle to the closed position and wait at least three minutes for the trip piston to fully reset.
- 2. Operate the tester (per manufacturer's directions) to apply the required current through the recloser. Note the number of operations to lockout.
- 3. The number of operations should match the data plate specifications and the settings selected by the assembly of the service kit parts. If the number of operations does not match, check to see if the recloser is correctly configured. If configuration is correct, adjust the trip linkage (refer to Figure 8).
  - A. If the recloser is performing too many operations, turn the self-locking nuts off the trip linkage (towards head casting) slightly. Repeat the test.
  - B. If the recloser is performing too few operations, turn the self-locking nuts onto the trip linkage (away from head casting) slightly (onto the pump piston). Repeat the test.
- 4. Perform the **High-Potential Withstand Test** as listed in the **Testing** section of this manual.
- 5. Return the recloser to operation after all the adjustments are correctly set.

## Testing

---

### WARNING

---

**Hazardous voltage. The switchgear (apparatus and control) and high-voltage transformer must be in a test cage or similar protected area to prevent accidental contact with the high-voltage parts.**

**Solidly ground all equipment. Failure to comply can result in death, severe personal injury, and equipment damage.**

T221.5

---

### CAUTION

---

**Radiation. At voltages up to the specified test voltages, the radiation emitted by the vacuum interrupter is negligible. However, above these voltages, radiation injurious to personnel can be emitted. See *Service Information S280-90-1, Vacuum Interrupter Withstand Test Voltage Ratings Information* for further information.** G109.2

---

### CAUTION

---

**Equipment damage. Never operate a vacuum recloser with a DC test source. The vacuum interrupters will be severely damaged if a DC arc interruption is attempted.**

T229.1

### High-potential withstand test

High-potential withstand tests provide information on the dielectric condition of the recloser. Perform the high-potential withstand test in a cage cage at 75 percent of the low frequency withstand voltage. *Service Information S280-90-1* or *S280-10-8* contains the dry, one-minute 60 Hz with standard voltage for each model of recloser.

Test the recloser at applicable voltage for 60 seconds in each of the following configurations

### Closed contacts test

1. Close the switch contacts.
2. Ground the switch.
3. Apply proper test voltage to the bushing terminal. The switch should withstand the test voltage for 60 seconds.

### Open contacts test

1. Open the switch contacts.
2. Ground the switch.
3. Ground the bushing on one side of the switch.
4. Apply proper test voltage to the ungrounded bushing. The switch should withstand the test voltage for 60 seconds.

5. Reverse the test and ground connections to the bushings.
6. Apply proper test voltage to the ungrounded bushing. The switch should withstand the voltage for 60 seconds.

### Withstand test results

The high-potential withstand tests provide information on the dielectric condition of the recloser.

If the recloser passes the closed-contacts test and fails the open-contacts test, the cause is likely to be in the interrupter assembly.

If the recloser fails the closed contacts test, the cause is likely to be a diminished electrical clearance or failed insulation.

### Contact operation test

The following test is intended to verify that the recloser contacts/mechanism are operating properly. With the recloser tanked:

1. Manually operate the recloser to lockout.
2. Slowly raise the operating handle to the closed position. Operate at a uniform rate which will allow the handle to swing through its complete arc in a period of approximately 5 to 15 seconds.
3. As soon as the contacts close, restrain the downward movement of the handle. Slowly allow the handle to return to the open position. This movement should take approximately 5 to 15 seconds and the contact should open.

Contacts should freely close and open while the mechanism is being slowly operated. If the contacts fail to freely open or close, inspect the recloser and repair or replace parts as required to achieve proper operation.

### Recommended test parameters

1. Use a test setup which will maintain a constant current and give accurate time.
2. Set-up test using *Reference Information R280-90-2 Low-Voltage AC Testing of Hydraulic Reclosers*.
3. Units are calibrated at the time of manufacture at approximately 3.5 times, 6 times and 18 times the continuous current rating of the series coil depending on the coil size.
4. All times are  $\pm 10\%$  of current or time, whichever value is greater.
5. To calibrate the low current value of approximately 4.0 times the continuous current rating, adjust the timing plate orifice size (Figure 9).

**Note:** Changes to the timing plate may be required.

6. To calibrate the high current value of approximately 18 times the continuous current rating, use the adjustable control valve.

**Note:** This can also affect mid-point times.

7. To calibrate the mid-current value of approximately 6 times the continuous current rating, use the adjustable control valve and timing plate.
8. Adjust the low and high current adjustment screws as follows:
  - To increase time, screw the adjustment screw upward or counter-clockwise.
  - To decrease time, screw the adjustment screw downward or clockwise.

**Note:** Since an adjustment to any point may affect the remaining points, verify all points are within stated values before completing the calibration process.

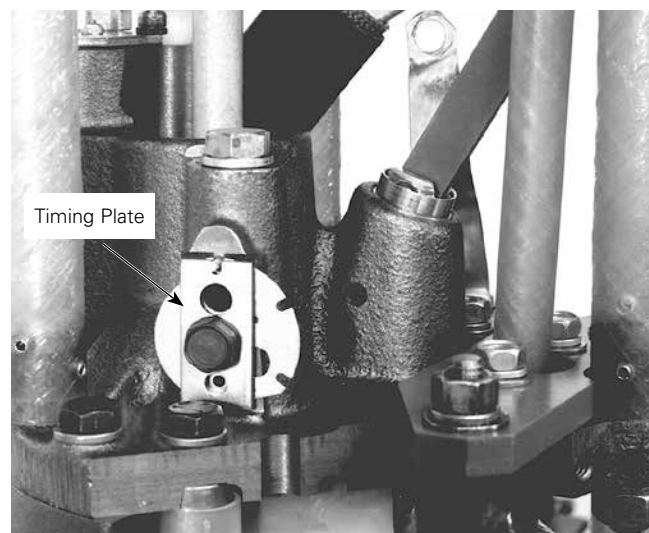

**Figure 9. Timing plate location.**

### Testing TCCs

The TCCs should be calibrated by testing two or more sequences at each current level for two or more current levels. The minimum current level that the unit should be tested at is 4X the coil rating. The second current level is 6X or 8X the coil rating.

Timing may be adjusted by opening or closing the appropriate holes in the timing orifice plate to meet the timing limits. The high pressure valve may be adjusted by turning the screw at the top of the LA178 adjustable control valve stop assembly (Figures 2 and 4). If an adjustment is made, the TCC tests must be repeated to verify that the adjustment was correct.

## Kit parts list

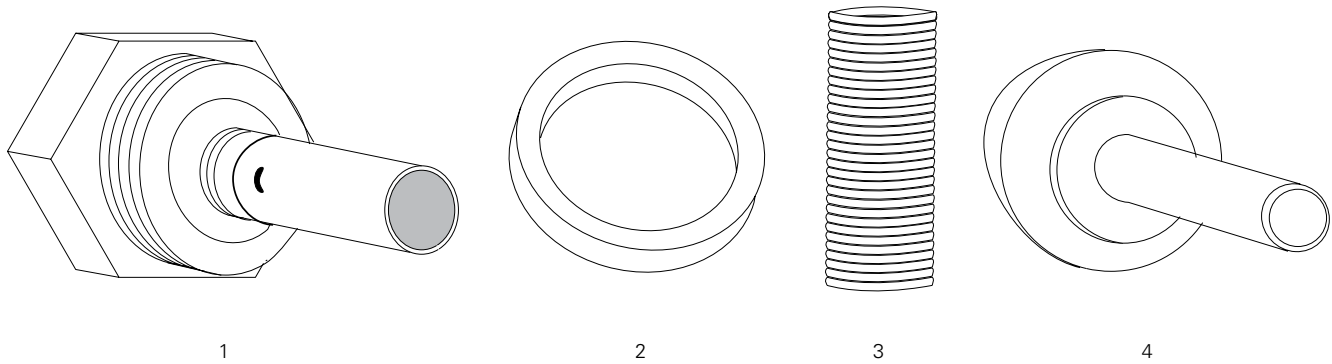

**Figure 10. Control valve kit components. (Drawings not to scale). Refer to Table 2 for part identification.**

**Table 2. Kit Contents**

Item	Part Number	Description	Quantity
1	LA178	Control Valve Outer Sleeve	1
2	KA3013-6	Brass Washer	1
3	LA113	Spring	1
4	L193	Control Valve Inner Sleeve/Stop Assembly	1
5	KA2048-460	Instruction Manual	1



**Eaton**  
 1000 Eaton Boulevard  
 Cleveland, OH 44122  
 United States  
 Eaton.com

**Eaton's Cooper Power Systems  
 Division**  
 2300 Badger Drive  
 Waukesha, WI 53188  
 United States  
 Eaton.com/cooperpowerseries

© 2015 Eaton  
 All Rights Reserved  
 Printed in USA  
 Publication No. MN280034EN  
 KA2048-460 Rev: 03

Eaton is a registered trademark.

All trademarks are property  
 of their respective owners.

**EATON**  
 Powering Business Worldwide

For Eaton's Cooper Power series product  
 information call 1-877-277-4636 or visit:  
[www.eaton.com/cooperpowerseries](http://www.eaton.com/cooperpowerseries).