

## Form 6 triple-single microprocessor-based yard mount recloser control installation and operation instructions

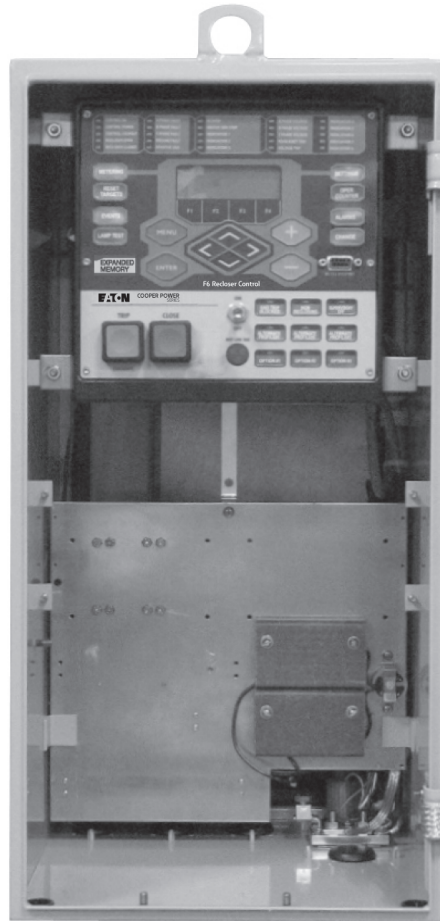

## **DISCLAIMER OF WARRANTIES AND LIMITATION OF LIABILITY**

The information, recommendations, descriptions and safety notations in this document are based on Eaton Corporation's ("Eaton") experience and judgment and may not cover all contingencies. If further information is required, an Eaton sales office should be consulted. Sale of the product shown in this literature is subject to the terms and conditions outlined in appropriate Eaton selling policies or other contractual agreement between Eaton and the purchaser.

THERE ARE NO UNDERSTANDINGS, AGREEMENTS, WARRANTIES, EXPRESSED OR IMPLIED, INCLUDING WARRANTIES OF FITNESS FOR A PARTICULAR PURPOSE OR MERCHANTABILITY, OTHER THAN THOSE SPECIFICALLY SET OUT IN ANY EXISTING CONTRACT BETWEEN THE PARTIES. ANY SUCH CONTRACT STATES THE ENTIRE OBLIGATION OF EATON. THE CONTENTS OF THIS DOCUMENT SHALL NOT BECOME PART OF OR MODIFY ANY CONTRACT BETWEEN THE PARTIES.

In no event will Eaton be responsible to the purchaser or user in contract, in tort (including negligence), strict liability or otherwise for any special, indirect, incidental or consequential damage or loss whatsoever, including but not limited to damage or loss of use of equipment, plant or power system, cost of capital, loss of power, additional expenses in the use of existing power facilities, or claims against the purchaser or user by its customers resulting from the use of the information, recommendations and descriptions contained herein. The information contained in this manual is subject to change without notice.

## Contents

<b>DISCLAIMER OF WARRANTIES AND LIMITATION OF LIABILITY</b> .....	<b>II</b>
<b>SAFETY FOR LIFE</b> .....	<b>IV</b>
<b>SAFETY INFORMATION</b> .....	<b>IV</b>
Safety instructions .....	iv
<b>PRODUCT INFORMATION</b> .....	<b>1</b>
Introduction .....	1
ANSI standards .....	1
Quality standards .....	1
Acceptance and initial inspection .....	1
Handling and storage .....	1
Control power .....	1
<b>FORM 6-TS RECLOSER CONTROL DESCRIPTION</b> .	<b>1</b>
Description .....	1
Control features .....	9
Communications .....	12
Control information .....	13
Control back panel .....	13
<b>INSTALLATION PROCEDURE</b> .....	<b>14</b>
Initial programming prior to installation .....	14
Control / recloser compatibility .....	14
Duty cycle monitor .....	14
Control cable .....	15
NOVA-TS junction box and cables .....	15
Reclose times .....	15
Mounting the control .....	15
Locking the control .....	16
Grounding the control .....	17
Customer connections for DC power and AC voltage sensing .....	18
Before placing the control and the recloser into service .....	24
Using removable inserts .....	30
<b>ACCESSORIES</b> .....	<b>32</b>
120 VAC GFI duplex outlet .....	32
Incoming power receptacles .....	32
Cable locking sleeves .....	32
BCT terminal block accessory .....	32
Heater receptacles .....	32
Communication board accessories .....	33
<b>TESTING</b> .....	<b>34</b>
Testing an installed control .....	34
Remove the control from service .....	35
Electrical testing of triple-single reclosers: NOVA-TS and NOVA STS .....	35
Return the control to service .....	36
<b>ADDITIONAL INFORMATION</b> .....	<b>37</b>
Replacement kits .....	37
Factory-authorized service centers .....	37
Factory testing and troubleshooting classes .....	37

# Form 6 triple-single microprocessor-based yard mount recloser control



## Safety for life



Eaton meets or exceeds all applicable industry standards relating to product safety in its Cooper Power™ series products. We actively promote safe practices in the use and maintenance of our products through our service literature, instructional training programs, and the continuous efforts of all Eaton employees involved in product design, manufacture, marketing, and service.

We strongly urge that you always follow all locally-approved safety procedures and safety instructions when working around high-voltage lines and equipment, and support our “Safety For Life” mission.

## Safety information

The instructions in this manual are not intended as a substitute for proper training or adequate experience in the safe operation of the equipment described. Only competent technicians who are familiar with this equipment should install, operate, and service it.

A competent technician has these qualifications:

- Is thoroughly familiar with these instructions.
- Is trained in industry-accepted high- and low-voltage safe operating practices and procedures.
- Is trained and authorized to energize, de-energize, clear, and ground power distribution equipment.
- Is trained in the care and use of protective equipment such as arc flash clothing, safety glasses, face shield, hard hat, rubber gloves, clampstick, hotstick, etc.

Following is important safety information. For safe installation and operation of this equipment, be sure to read and understand all cautions and warnings.

### Hazard Statement Definitions

This manual may contain four types of hazard statements:

#### **DANGER**

Indicates an imminently hazardous situation which, if not avoided, will result in death or serious injury.

#### **WARNING**

Indicates a potentially hazardous situation which, if not avoided, could result in death or serious injury.

#### **CAUTION**

Indicates a potentially hazardous situation which, if not avoided, may result in minor or moderate injury.

#### **NOTICE**

Indicates a potentially hazardous situation which, if not avoided, may result in equipment damage only.

### Safety instructions

Following are general caution and warning statements that apply to this equipment. Additional statements, related to specific tasks and procedures, are located throughout the manual.

#### **DANGER**

**Hazardous voltage. Contact with hazardous voltage will cause death or severe personal injury. Follow all locally-approved safety procedures when working around high- and low-voltage lines and equipment.**

G103.3

#### **WARNING**

**Before installing, operating, maintaining, or testing this equipment, carefully read and understand the contents of this manual. Improper operation, handling, or maintenance can result in death, severe personal injury, and equipment damage.**

G101.0

#### **WARNING**

**This equipment is not intended to protect human life. Follow all locally-approved procedures and safety practices when installing or operating this equipment. Failure to comply can result in death, severe personal injury, and equipment damage.**

G102.1

#### **WARNING**

**Power distribution and transmission equipment must be properly selected for the intended application. It must be installed and serviced by competent personnel who have been trained and understand proper safety procedures. These instructions are written for such personnel and are not a substitute for adequate training and experience in safety procedures. Failure to properly select, install, or maintain power distribution and transmission equipment can result in death, severe personal injury, and equipment damage.**

G122.2

#### **WARNING**

**Overlapping zones of protection are required. Upstream protection device settings must provide adequate overcurrent protection in the event of a system or product failure. Failure to properly select appropriate upstream coordination protection can result in death, severe personal injury, and equipment damage.**

G172.0

## Product information

### Introduction

*Service Information MN280085EN* provides installation and operation instructions for the Form 6 Triple-Single yard mount recloser control.

Refer to the following information as appropriate for your version of ProView software:

- *Service Information S280-70-9 Form 6-TS Recloser Control Programming Guide: ProView 4.X.X software*
- *Service Information S280-70-23 Form 6-TS Recloser Control Programming Guide: ProView 5.X.X software*
- The Form 6 Triple-Single (Form 6-TS) control is designed for use with these reclosers:
- NOVA-TS Triple-Single (3) reclosers. Refer to *Service Information MN280045EN NOVA-TS Recloser Installation and Operation Instructions*.
- NOVA STS Single-Tank, Triple-Single recloser. Refer to *Service Information MN280046EN NOVA STS Recloser Installation and Operation Instructions*.

### Read this manual first

Read and understand the contents of this manual and follow all locally approved procedures and safety practices before installing or operating this equipment.

### Additional information

These instructions cannot cover all details or variations in the equipment, procedures, or process described, nor provide directions for meeting every possible contingency during installation, operation, or maintenance. When additional information is desired to satisfy a problem not covered sufficiently for the user's purpose, contact your Eaton representative.

### ANSI standards

Eaton Cooper Power series reclosers are designed and tested in accordance with the following ANSI standards: C37.60 and C37.85 and ANSI Guide C37.61.

### Quality standards

ISO 9001-Certified Quality Management System.

### Acceptance and initial inspection

Each Form 6-TS recloser control is completely assembled, tested, and inspected at the factory. It is carefully calibrated, adjusted and in good condition when accepted by the carrier for shipment.

Upon receipt, inspect the carton for signs of damage. Unpack the control and inspect it thoroughly for damage incurred during shipment. If damage is discovered, file a claim with the carrier immediately.

### Handling and storage

Be careful during handling and storage of the control to minimize the possibility of damage. If the control is to be stored for any length of time prior to installation, provide a clean, dry storage area. If storage is in a humid atmosphere, make provisions to keep the control circuitry energized.

### Control power

All operating power is obtained from the substation battery bank. There are two power supply options available for the Form 6-TS yard mount recloser control. Examine the voltage decal on the back of the recloser control to verify the correct voltage rating.

The following power supply option is available and configured at the factory:

- 40 VDC –140 VDC  
Burden 14 Watts

**Note:** The 40 VDC – 140 VDC power supply is a universal power supply adaptable for either 48 VDC or 125 VDC substation batteries.

A 120/240 VAC thermostatically controlled heater for humidity control is included as standard.

Refer to the **Customer connections for DC power and AC voltage sensing** section of this manual for incoming power wiring illustrations for the Form 6-TS yard mount recloser control.

## Form 6-TS recloser control description

### Description

The Form 6 Triple-Single (Form 6-TS) control is designed for use with these reclosers to provide protection, metering, and automation of distribution feeders in substation and line applications:

- NOVA-TS Triple-Single recloser
- NOVA STS Single-Tank, Triple-Single recloser

The Form 6-TS control operates the triple-single reclosers representing phases A, B, and C.

**Note:** Phase A, B, and C sequence positions are independent of each other.

The Form 6-TS control uses three modes of operation. All modes are configured through the ProView user interface software or the front panel MMI.

- Three-phase trip, Three-phase lockout (ganged)
- Single-phase trip, Three-phase lockout
- Single-phase trip, Single-phase lockout

The Form 6-TS yard mount microprocessor-based recloser control includes extensive system protection functionality, including phase, ground, and negative sequence overcurrent protection, over/underfrequency, and voltage protection, directionality, sensitive ground fault, and sync check.

## Form 6 triple-single microprocessor-based yard mount recloser control

Analysis tools include data profiler, fault locating, event recording, TCC Editor II, Idea Workbench, and oscillography functions, including oscillography replay.

Metering functions include demand and instantaneous current on a per-phase basis, instantaneous voltage and power factor on a per-phase basis, and power (real, reactive, apparent).

The front panel LCD display is used to configure the operating settings for the control. It is also used to display metering, counter information, control parameters, reset alarms, and provide diagnostic information.

Control parameters can also be programmed via a personal computer connected to the control through the front panel RS-232 port. Control programming, interrogation, and

operations are performed with Form 6 ProView interface software on a personal computer.

The ProView interface program software includes additional functions used to create and graphically display Time Current Curves and provide the Idea Workbench for configuring user-selected inputs and outputs, configurable event and alarm data, and selectable communication points for serial communication.

The control operates on 50 and 60 Hz systems.

The control can be configured, by the factory or by the user, for a wide variety of applications. If user requirements change, the control functions can be modified to meet the new requirements.

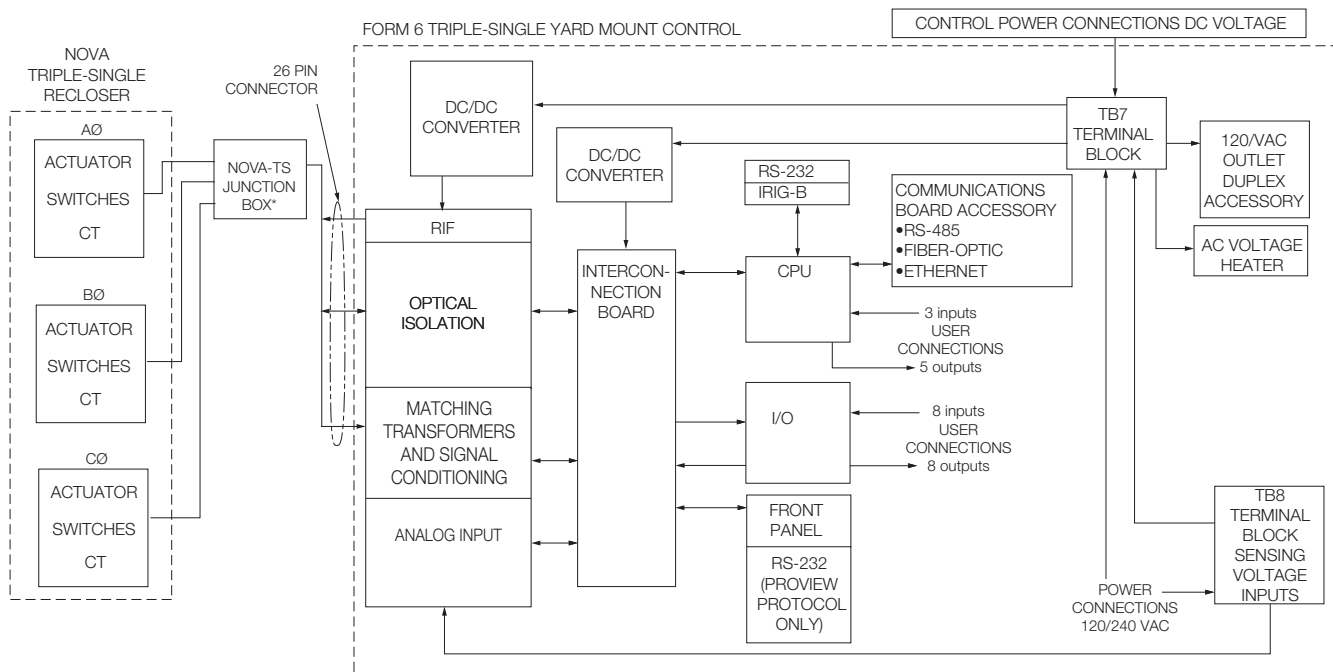

\*The NOVA-TS recloser connects to the Form 6-TS control via cable through a junction box.  
The NOVA STS recloser connects directly to the Form 6-TS control via cable (no junction box).

**Figure 1. Form 6-TS yard mount recloser control operational flow diagram**

### Theory of operation

A functional block diagram of the Form 6-TS yard mount control is shown in **Figure 1**. Current sensing is provided by three current transformers located in the recloser and interfaced to the Form 6-TS control via control wiring.

- NOVA-TS: via a junction box and control cable
- NOVA STS: via control cable

This wiring also supplies Trip, Close, and Recloser status, and connects to the Recloser Interface (RIF) module to provide isolation for reliable operation. Voltages for metering are connected to the analog input module.

Line current flowing through the recloser is converted by the CPU module to a digital signal suitable for metering and fault current calculations. Data sampling occurs at a rate of 64

times per cycle. The CPU contains a data acquisition section that uses the acquired samples to compute the fundamental currents and voltage for use in overcurrent, under/overvoltage, and under/overfrequency protection, as well as currents and voltages for metering functions. The current for overcurrent protection is calculated on a sub-cycle basis; it includes only the fundamental and DC component.

When the phase or ground current exceeds its programmed minimum-trip value and associated time-current-curve (TCC) timing, the control initiates the programmed sequence of recloser tripping and reclosing operations via the CPU and RIF modules. If the fault is temporary, the control resets to the start of its operating sequence after a preset time delay. If the fault is permanent, the control performs its complete programmed sequence of reclose commands and locks out with the recloser open.

Once locked out, the control must be closed via the operator panel or SCADA communications. This resets the control to the start of the operating sequence.

The following chain of events occurs for an operating sequence of two trips to lockout (one trip on TCC1, one trip on TCC2):

1. The overcurrent signal is integrated with time on the selected curve for the first trip operation (TCC1) to produce the signal which energizes the trip circuit.
2. Energizing the trip circuit connects the supply to the trip solenoid to open the recloser.
3. Upon opening, the control starts timing on the first reclosing interval-delay time.
4. Upon expiration of this reclosing interval-delay, a closing signal is issued from the control, closing the recloser, and selecting the time-current characteristics for the second trip operation (TCC2).
5. If current remains above the minimum-trip level, the recloser will trip on TCC2 and lockout the recloser.

### Phase operation

In *Three-Phase Trip, Three-Phase Lockout* (ganged) mode, all three phases simultaneously trip and close.

In *Single-Phase Trip, Three-Phase Lockout* and *Single-Phase Trip, Single-Phase Lockout* modes, each phase operates independently with protection parameters the same for all three phases.

In *Single-Phase Trip, Three-Phase Lockout* mode, all three phases trip to lockout when one phase sequences to lockout.

In *Single-Phase Trip, Single-Phase Lockout* mode, each phase independently sequences to lockout.

### Ground operation

In *Three-Phase Trip, Three-Phase Lockout* (ganged) mode, all three phases trip and close.

In *Single-Phase Trip, Three-Phase Lockout* and *Single-Phase Trip, Single-Phase Lockout* modes, ground tripping is active when all three phases are closed. Ground trip is disabled during the reclose interval of any one phase.

For faults above the ground minimum trip value, and below the phase minimum trip value, all three phases trip on ground and advance to the next sequence position.

For faults above the phase and ground minimum trip value, the control trips on the phase(s) above phase minimum trip, operating on the phase or ground TCC, whichever is faster. Only tripped phases advance in sequence and are counted as phase operations.

### Phase/ground sequencing

Phase and ground share the same sequence position. As the position sequence advances, the phase and ground TCCs advance together to maintain proper coordination with upline and downline devices. This is applicable for temporary and permanent faults including faults on multiple phases.

### Control front panel

The Form 6 control front panel is illustrated in **Figure 2**.

The front panel is separated into two clearly identified, color-coded sections:

- The top portion of the front panel is used for programming the control and providing LED status indication.
- The lower portion of the front operating panel is used for operating the control and recloser.

The control includes a Power Save feature that will turn off the backlit LCD display and all LEDs (except Hot Line Tag) if no front panel keypad is pressed within ten minutes. Pressing the LAMP TEST key will re-activate the display and LEDs.

**Note:** The Power Save feature is a ProView interface software default setting. This feature can be disabled via the ProView interface software.

The control includes a Reset Menu feature that will cause the LCD display to revert to the Recloser Status menu after ten minutes of inactivity.

**Note:** The ten minute timer and Recloser Status menu is a ProView interface software default setting. The menu selection and timer can be changed via the ProView interface software.

### Front panel text messaging

The LCD messages are accessed from the front panel by following the Text Messages menu path. This menu displays any active user-configured text messages.

Up to fourteen user-configurable text messages can be programmed via the Idea Workbench. Refer to *Service Information S280-70-9 (ProView 4.X.X)* or *S280-70-23 (ProView 5.X.X) Form 6-TS Control Programming Guide* for information on programming the text messages.

These text messages appear on the front panel LCD and can be programmed to appear for alarm or other conditions.

Text messages displayed on the front panel are limited to four lines of 20 characters each (including spaces). Text messages can also be accessed by pressing the LAMP TEST one-touch analysis key on the front panel.

The default text message displays the mode of the triple-single configuration and the status of each phase.

# Form 6 triple-single microprocessor-based yard mount recloser control

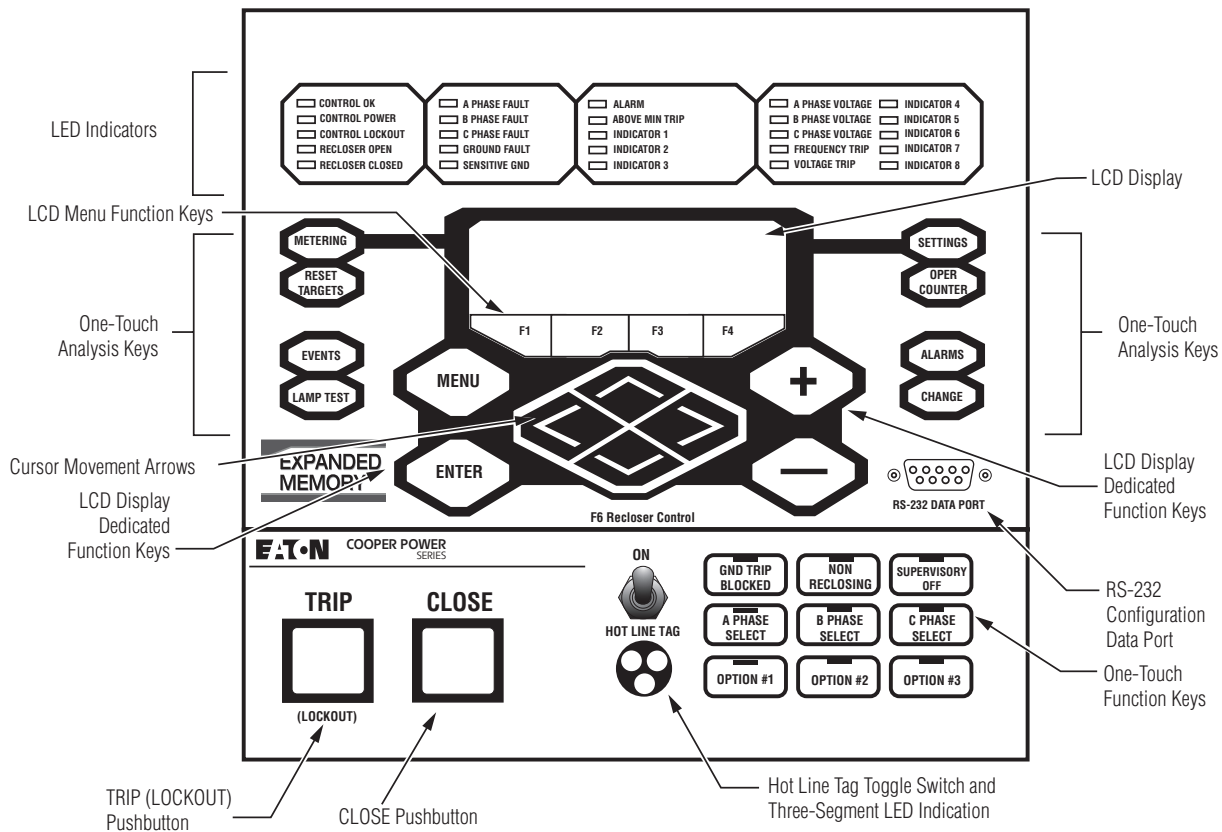

**Figure 2. Form 6-TS yard mount recloser control front panel**

## Programming panel

The Programming panel has the following sections:

### One-touch analysis keys

There are eight analysis keys (Figure 3) that allow one-button access to a variety of control and monitoring functions that appear in the LCD display.

**Note:** The label inserts can be customized, but the analysis key functions remain the same.

Pressing these buttons causes the following information to display or function to occur:

**Note:** When pressing a membrane pushbutton, always press and hold for 0.5 seconds to ensure the button press is recognized by the device.

**METERING:** Displays the systems instantaneous metering values for current and voltage on the LCD display.

**RESET TARGETS:** Resets the fault target indicators on the operator panel.

**EVENTS:** Displays the last 25 events from the Sequence of Events log.

**LAMP TEST:** This button functions two ways:

- Press and immediately release this button to display the front panel LED status.
- Press and hold the LAMP TEST button for two seconds to enable the actual LAMP TEST feature. All operator panel LEDs are illuminated for verification of proper connection and operating status of all indicator lights. All status indicators will then return to their previous state. While in the LAMP TEST mode, the control response to operator panel keys is disabled, except for the TRIP (LOCKOUT), CLOSE, and HOT LINE TAG switches.

**SETTINGS:** Displays recloser settings on the LCD display.

**OPER COUNTER:** Displays the total number of trip operations and target counters for each A, B, and C Phase; Ground, and Sensitive Ground on the LCD display.

**ALARMS:** Provides status information on the LCD display for all recloser alarms.

**CHANGE:** Allows the user to change the state of the control functions on the operator panel function keys.

**Note:** The CHANGE mode is a ten second period in which one function setting can be changed. If no change is made in that time, the control returns to the current setting.



**LCD Display**

The LCD Display is a backlit 4-line, 20-character display that provides extensive distribution system, recloser, and control status information via the navigation keypads (**Figure 3**).

**Note:** The LCD display panel contrast is field-adjustable to allow for various mounting heights and applications. Press the MENU key and then press the (+) or (-) key to increase or decrease the contrast.

The four LCD navigation buttons are as follows:

- MENU: Identifies the LCD Display menu options.
- ENTER: Selects a menu option.
- +: Increases value selection.
- : Decreases value selection.

The four LCD menu function keys activate specific menu commands. When a command appears in the LCD display directly above one of the four LCD menu function keys, the user can press the key to accept/select the command.

The four LCD menu function keys are as follows:

- F1
- F2
- F3
- F4

The four cursor movement arrows allow movement in the following directions:

- ◀ Moves the cursor left.
- ▶ Moves the cursor right.
- ▲ Moves the cursor up one line.
- ▼ Moves the cursor down one line.

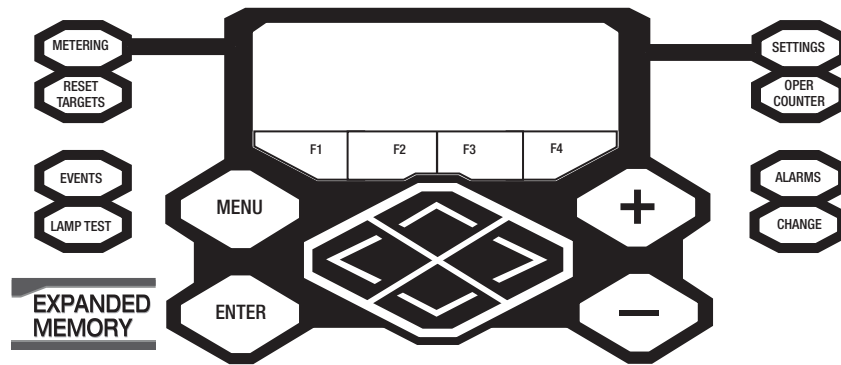

**Figure 3. Analysis keys, LCD display, LCD menu function keys, and cursor movement arrows**

**Status Indicator LEDs**

The status indicator LEDs (**Figure 4**) in the Programming section of the Operator Panel give instant information on the control and recloser status:

All of the default status indicators LEDs (except for CONTROL OK, CONTROL POWER, and ALARM) can be reconfigured via

the Idea Workbench. Refer to *Service Information S280-70-9 (ProView 4.X.X)* or *S280-70-23 (ProView 5.X.X) Form 6-TS Control Programming Guide* for additional information.

The label inserts can be user-customized. Refer to **Using removable inserts** section of this manual for additional information.

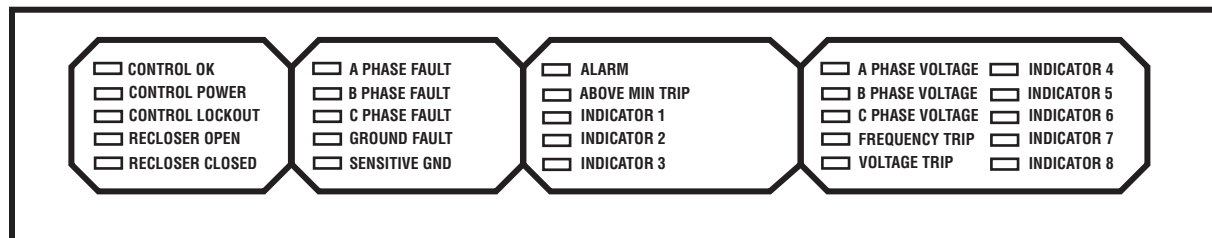

**Figure 4. Status indicator LEDs**

**CONTROL OK:** The green LED indicates the control is operating normally and not in an alarm state.

The CONTROL OK LED will not be illuminated during these alarms (indicated by the red ALARM LED and displayed in the alarm status log):

- RAM Failure: This alarm indicates a failed RAM memory test.

- ROM Failure: This alarm indicates a failed ROM memory test.
- No AC Present: This alarm indicates AC power was unavailable for 10 continuous seconds. This alarm resets when AC power is restored.
- Internal Power Failure: This alarm indicates internal control operation power was outside of its operating tolerance for more than 20 seconds. This alarm resets when the internal control operation power returns to operation within its normal tolerances.

## Form 6 triple-single microprocessor-based yard mount recloser control

- **RIF Comm Failure:** This alarm indicates a loss of communication from the RIF (Recloser Interface) circuit board to the main CPU circuit board. This alarm resets if communication is re-established.

**CONTROL POWER:** The green LED indicates there is adequate VTC voltage to trip the recloser. This LED does not indicate the presence of AC power.

**CONTROL LOCKOUT:** The steady green LED indicates the control for all three phases is in a locked out state, i.e. a reclosing sequence is not in progress on any phase. In Single-Phase Trip/Single-Phase Lockout mode the blinking green LED may indicate that the control for one or two phases is in a locked-out state, i.e. a reclosing sequence is not in progress on those one or two phases. This LED (blinking or steady) does not indicate that any phase is open.

**RECLOSER OPEN:** The steady green LED indicates all three phases are in the open position. In Single-Phase Trip/Single-Phase Lockout and during a sequence in Single-Phase Trip/Three-Phase Lockout mode the blinking green LED indicates one or two phases are in the open position.

**RECLOSER CLOSED:** The steady red LED indicates all three phases are in the closed position. In Single-Phase Trip/Single-Phase Lockout and during a sequence in Single-Phase Trip/Three-Phase Lockout mode the blinking red LED indicates one or two phases are in the closed position.

**Note:** There are several conditions that will cause the alternate blinking of the CONTROL LOCKOUT, RECLOSER OPEN, and RECLOSER CLOSED LEDs: Failure to Trip, Failure to Close, Interrupter Malfunction, and 52a/b Disagreement.

The LED blinking pattern for these conditions is the CONTROL LOCKOUT green LED and RECLOSER CLOSED red LED alternating with the RECLOSER OPEN green LED. The red ALARM LED will also be illuminated.

This LED blinking pattern is different than the continuous blinking of all three LEDs that occurs when all three reclosers do not have the same status, i.e. OPEN or CLOSED. To determine the actual status of each recloser (phase), refer to the Form 6-TS control front panel RECLOSER STATUS LCD menu display.

**A PHASE FAULT, B PHASE FAULT, C PHASE FAULT:** The red LEDs indicate A, B, and/or C phase current was either the maximum phase current or within 20% of the maximum when a trip signal was issued.

**GROUND FAULT, SENSITIVE GROUND FAULT:** The red LEDs indicate that a Ground and/or Sensitive Earth Fault tripping function was asserted at the time the trip signal was asserted.

**ALARM:** The red LED indicates an alarm has been issued. Review the alarm status and log on the LCD display for the specific alarm.

**Note:** If a Battery Alarm occurs, de-select the Pole Mounted Control checkbox in the ProView application software Configure>System Configuration dialog box. Refer to *S280-70-9 Form 6-TS Control Programming Guide* for additional information.

**ABOVE MINIMUM TRIP:** The red LED indicates the current exceeds the level set for minimum trip.

**A PHASE VOLTAGE, B PHASE VOLTAGE, C PHASE VOLTAGE:** Indicates a presence of voltage on the respective phases. The Single-Phase Undervoltage Pickup setting controls the voltage indication for the front panel LEDs as defined in the Voltage setting dialog box for the active setting profile. Refer to Settings-Voltage in Schemes section of *Service Information S280-70-9 (ProView 4.X.X) or S280-70-23 (ProView 5.X.X) Form 6-TS Control Programming Guide*.

**FREQUENCY TRIP:** Indicates the recloser tripped due to an under or over frequency condition.

**VOLTAGE TRIP:** Indicates the recloser tripped due to an under or over voltage condition.

**INDICATOR 1, INDICATOR 2, INDICATOR 3, INDICATOR 4, INDICATOR 5, INDICATOR 6, INDICATOR 7, INDICATOR 8:** Customizable LEDs that are used with functions programmed through the Idea Workbench. The LED indicators do not have active default values. The LEDs are illuminated when the status configured via the Idea Workbench is present.

### Operating panel

The Operating section includes the following sections:

#### RS-232 configuration data port

The RS-232 connector (shown in **Figure 2**) on the front operating panel allows direct connection to a personal computer without any special cables or connectors. This port is used only for configuring the control with ProView application software. All settings, metering, events, and oscillography data are available from this port. The port is Data Communication Equipment (DCE) wired for direct connection to a personal computer.

A 9-pin RS-232 cable (Catalog Number KME5-66) to connect from the PC to the RS-232 data port is available as an accessory.

#### HOT LINE TAG ON/OFF toggle switch and LED indicator

### WARNING

**Hazardous voltage. Do not use Hot Line Tag as a substitute for a visible disconnect. Always establish a visible disconnect prior to performing any work requiring a de-energized line. Failure to comply may cause death, severe personal injury, or equipment damage.** T276.0

Hot Line Tag is provided for live-line work applications. All closing operations are disabled when the Hot Line Tag feature is activated.

### IMPORTANT

Hot Line Tag activation does not cause the recloser to trip open. It only prevents the recloser from closing.

**IMPORTANT**

Hot Line Tag is intended solely for live-line work applications, such as maintenance, repairs or improvements to the distribution system, that occur while the line remains energized.

Hot Line Tag prevents all closing attempts from the control and shifts protection to one trip-to-lockout on the composite curve of the Hot Line Tag definite time and the TCC1 curve (whichever is faster).

**Note:** Refer to **Single-Phase Trip/Single-Phase Lockout Mode Hot Line Tag Behavior Information** section for specific ProView 4.0.1 version and below recommendation.

Hot Line Tag takes precedence over Cold Load Pickup, Non-Reclosing, and Fast Trips Disabled.

Hot Line Tag is activated from either the operator panel toggle switch, serial communications, or a discrete SCADA function. All sources must be off to de-activate Hot Line Tag.

To activate the function from the operator panel, flip toggle switch up to the ON position. See **Figure 5**. The LED indicator illuminates when the function is active.

The Hot Line Tag function may only be reset by the source which initiates it. For example, if Hot Line Tag is activated at the operator panel, the reset function is only possible at the operator panel, and not via SCADA command.

**IMPORTANT**

If the power save feature is enabled (default), and more than ten minutes elapses since the last panel operation, all the LEDs, except HOT LINE TAG (if active), will turn off.

**Single-Phase Trip/Single-Phase Lockout Mode Hot Line Tag Behavior Information.**

Applies only to ProView 4.0.1 version software and below.

**WARNING**

**Hazardous voltage. When Hot Line Tag is enabled in the single-phase trip/single-phase lockout mode and the overcurrent element times out first, only the faulted phase(s) will open. The non-faulted phase(s) will remain closed and Hot Line Tag will only prevent a reclose/close of the opened phase(s).**

**When in single-phase trip/single-phase lockout mode, set the Hot Line Tag response time to be faster than the overcurrent response time to ensure all faulted and non-faulted phases open.**

**Failure to do so may result in death, severe personal injury, and equipment damage.**

T373.1

With Hot Line Tag enabled in the single-phase trip/single-phase lockout mode and the overcurrent element times out, only the faulted phase(s) will open and the non-faulted phase(s) will remain closed. Hot Line Tag will only prevent a reclose/close of the opened phase(s).

**TRIP (Lockout) pushbutton**

The TRIP pushbutton (**Figure 5**) provides front-panel access to trip (lockout) the recloser. When pressed, the TRIP pushbutton opens the recloser and locks out the control.

**Note:** In the event of main microprocessor failure, the trip circuit can operate independent of the main microprocessor.

**Close pushbutton**

When pressed, the CLOSE pushbutton (**Figure 5**) returns the control to the initial or home sequence position, closing the recloser. The control is ready for the start of a new trip/close sequence.

**Note:** The Close Malfunction alarm must be reset before Closing will be allowed.

**Note:** Pressing the CLOSE pushbutton from the Lockout position initiates Cold Load Pickup (CLPU) protection, if the feature is enabled.

The user does have the ability to block COLD LOAD PICKUP through the LCD menu or by configuring one of the Option one-touch function keys via the Idea Workbench feature in ProView.

If the recloser is closed, pushing and holding the CLOSE pushbutton does not activate the Cold Load Pickup feature. See **Cold load pickup** in the **Control features** section of this manual.

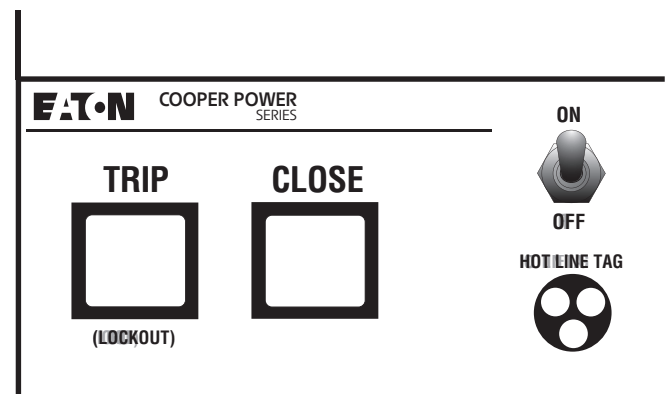

**Figure 5. TRIP (Lockout) pushbutton; CLOSE pushbutton; Hot Line Tag switch and Hot Line Tag red indicator LEDs**

**One-touch function keys**

Quick access to frequently operated Form 6-TS control features is provided with nine function key pushbuttons on the control operator panel.

## Form 6 triple-single microprocessor-based yard mount recloser control

The Form 6 control operator panel one-touch function keys are illustrated in **Figure 6**.

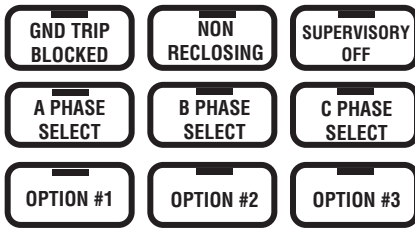

**Figure 6. Operator panel function keys**

Red LEDs located on each function key indicate the status of the function, regardless of local or remote activation. For example, if Ground Trip Blocked is activated from a SCADA signal, the red indicator will illuminate even though it was not activated from the operator panel.

**Operator panel function key activation or de-activation** requires the operator to first press the CHANGE key to enter the CHANGE mode. A function must then be selected or de-selected within ten seconds to activate or de-activate the function. Once selected, the control returns to normal operation until prompted for another change request. This prevents accidental changing of functions or features.

**Note:** Only one function can be changed per each CHANGE mode activation.

### GND TRIP BLOCKED

The Ground Trip Blocked function blocks all ground sensing in the control for the active profile. This red indicator is illuminated when Ground Trip Block is activated from the serial port, I/O, the interface software, or locally (via the front panel) causing the control to block all ground sensing.

### NON RECLOSING

The control is operating in a non-reclosing mode when the NON RECLOSING red indicator is illuminated. Non-reclosing mode disables any automatic reclosing operations. Non-reclosing does not alter the active TCC. Activation is possible from the SCADA port, I/O, the interface software, or locally (via the front panel).

### SUPERVISORY OFF

When the SUPERVISORY OFF red indicator is illuminated, supervisory commands are blocked. Supervisory functions through the back panel serial communication ports and the discrete I/O are blocked. Serial communications through the front panel RS-232 port remain active independent of the status of the SUPERVISORY OFF switch. Activation of this function key is restricted to the operator panel and is accomplished by pressing the CHANGE key and then pressing the SUPERVISORY OFF key. Operational data and metering information are available while the control is in the SUPERVISORY OFF position. The TRIP and CLOSE pushbuttons and Hot Line Tag are active independent of the SUPERVISORY OFF function.

A phase select, b phase select, c phase select

The Form 6 Triple-Single control when in Single-Phase Trip/Single-Phase Lockout mode has phase selection keys available for the user to indicate only which phase of the triple-single recloser will operate when the manual TRIP (LOCKOUT) and CLOSE pushbuttons on the Form 6-TS operator panel are pressed. When the TRIP or CLOSE buttons are pressed, only the phases that are selected (LED on) will trip or close.

Manual operation of the yellow handles on the triple-single recloser is used to open and lockout the phases, and to disable the electrical and supervisory closing. The recloser mode of operation determines which phases open and close. The Form 6 Triple-Single control initiates the close signal.

### **WARNING**

**Hazardous voltage. Do not rely on the open position of the yellow operating handle; it does not ensure that the line has been de-energized. Always establish a visible disconnect. Failure to follow proper safety practices can result in contact with high voltage, which will cause death or severe personal injury.**

G116.0

### **IMPORTANT**

Pushing the yellow operating handle to the CLOSE position **will not** close the recloser. All close operations are initiated by the Form 6 Triple-Single control.

*Three-Phase Trip – Three-Phase Lockout (ganged)*

or

*Single-Phase Trip – Three-Phase Lockout*

If the control is in Three-Phase Trip – Three-Phase Lockout (ganged) mode or Single-Phase Trip – Three-Phase Lockout mode, all three phases are permanently selected and the A PHASE SELECT, B PHASE SELECT, and C PHASE SELECT LEDs are illuminated.

When one phase is opened with the yellow operating handle, all three phases open and lockout. The RECLOSER OPEN and CONTROL LOCKOUT indicator LEDs illuminate on the control panel.

With the yellow operating handle of the appropriate phase in the CLOSE position, press the CLOSE pushbutton on the control operator panel. All three phases close and the RECLOSER CLOSED LED illuminates.

*Single-Phase Trip – Single-Phase Lockout*

When in Single-Phase Trip – Single-Phase Lockout mode any combination of phases can be selected and the respective PHASE SELECT LED illuminates. Each selected phase must be closed individually.

When the selected phase is opened with the yellow operating handle, only that phase opens and locks out. The RECLOSER OPEN, RECLOSER CLOSED, and CONTROL LOCKOUT indicator LEDs blink on the control panel.

The default text message on the LCD displays the mode of the triple-single configuration and the status of each phase.

With the yellow operating handle of the selected phase in the CLOSE position, press the CLOSE pushbutton on the control panel. The phase closes and the RECLOSER CLOSED LED illuminates.

**Note:** Refer to **Single-Phase Trip/Single-Phase Lockout Mode Hot Line Tag Behavior Information** section for specific ProView 4.0.1 version and below recommendation.

## IMPORTANT

If the power save feature is enabled (default), and more than ten minutes elapses since the last panel operation, all the LEDs, except HOT LINE TAG (if active), will turn off.

Verify the phase or phases you want activated are selected prior to pressing the TRIP or CLOSE button.

### Single-Phase Trip/Single-Phase Lockout Mode Hot Line Tag Behavior Information.

Applies only to ProView 4.0.1 version software and below.

## WARNING

**Hazardous voltage. When Hot Line Tag is enabled in the single-phase trip/single-phase lockout mode and the overcurrent element times out first, only the faulted phase(s) will open. The non-faulted phase(s) will remain closed and Hot Line Tag will only prevent a reclose/close of the opened phase(s).**

**When in single-phase trip/single-phase lockout mode, set the Hot Line Tag response time to be faster than the overcurrent response time to ensure all faulted and non-faulted phases open.**

**Failure to do so may result in death, severe personal injury, and equipment damage.**

T373.1

With Hot Line Tag enabled in the single-phase trip/single-phase lockout mode and the overcurrent element times out, only the faulted phase(s) will open and the non-faulted phase(s) will remain closed. Hot Line Tag will only prevent a reclose/close of the opened phase(s).

### OPTION #1, OPTION #2, AND OPTION #3

The OPTION #1, OPTION #2, and OPTION #3 function keys must be programmed via the ProView Idea Workbench software.

The OPTION LEDs are illuminated when the options configured via the Idea Workbench are selected. Refer to *Service Information S280-70-9 Form 6-TS Control Programming Guide* for additional information.

These OPTION keys provide a momentary signal. For instance, these keys can be programmed to toggle control status, protective functions, or a momentary input pulse.

The OPTION #1, OPTION #2, and OPTION #3 function keys are intentionally not defaulted to any function. The functions are assigned to each OPTION key via the Idea Workbench application.

### Control features

The Form 6-TS yard mount recloser control offers numerous standard features and accessories that allow the user the utmost flexibility applying the recloser control.

### Control security

The Form 6-TS yard mount recloser control has multiple customer-programmable security codes to limit control programming and viewing function access to authorized personnel. The front panel Man-Machine Interface (MMI) includes a user-selected security code to access the settings. Plus, the ProView interface software has its own security levels for multiple-user access.

Refer to *Service Information S280-70-9 (ProView 4.X.X) or S280-70-23 (ProView 5.X.X) Form 6-TS Control Programming Guide* for additional information.

### Protection profiles

Four protection profiles capable of fully specifying control operation are standard in the control. Each protection profile includes the following as a minimum:

- Overcurrent Protection
- Over/Undervoltage Protection
- Over/Underfrequency Protection
- Directional Protection
- Hot Line Tag Functionality
- Sync Check
- Sensitive Earth Fault Protection
- Sequence Coordination
- Operation Settings

### Time current curves

Time-current curves are available for numerous functions, including fast and delayed operations for phase, ground, and negative sequence protection. Each time-current is selected from a defined fifty curves which can be further customized by the user. The time-current curves are also selected from a graphical TCC Editor II to visualize any modifications prior to configuring the control.

The time-current curves include the following modifications for phase, ground, and negative sequence protection:

- Time Multiplier with a range of 0.1 to 25 in .1 increments.
- Time Adder with a range of 0 to 30 seconds in .01 second increments.

## Form 6 triple-single microprocessor-based yard mount recloser control

- Minimum Response Time with a range of 0.01 to 1 seconds in .001 second increments.
- High Current Trip multiplier with a range of 1 to 32 multipliers in increments of 0.1.
- High Current Trip Time Delay with a range of 0.01 to .150 second in .001 second increments.
- Time Dial Reset co-efficient with a range of .1 to 30 seconds in 1 second increments.

### Sequence coordination

Sequence Coordination eliminates nuisance tripping through trip coordination. It allows the control to step through selected operations in the operating sequence without tripping. The number of Sequence Coordination advances is programmable from one to three operations to provide trip coordination with a downline recloser. This feature is independently selectable for each protection profile.

### Cold load pickup

The control includes a Cold Load Pickup feature to prevent the control from tripping while energizing non-fault system loads. This feature has independently programmable minimum trip value time-current curve, reclose interval, and number of independent operations to lockout for each protection profile. Cold Load Pickup also includes TCC Multipliers, TCC Adders, Minimum Response Time, Time Dial Reset, and High Current Lockout. Also, direct values, not multiples of minimum trip, are provided for high current lockout.

### Fast trips disabled

The control includes a Fast Trips Disabled feature to modify protection, so that all trip operations use the programmed TCC2. This feature is independently selectable for each protection profile. All trip operations will time on TCC2. Typically, TCC1 is fast and TCC2 is delayed. So, as an example, the control will change its sequence from 2 fast and 2 delayed operations to 2 operations on TCC2 when Fast Trips Disabled is active.

### High current lockout

The High Current Lockout feature will automatically lockout the control on the selected operation when current exceeds a programmable level. The active trip numbers for the lockout is selectable for phase, ground, and negative sequence. This feature is independently selectable for each protection profile.

### Sensitive ground/earth fault operation

The control has a Sensitive Ground/Earth Fault Trip feature that provides tripping of the recloser after a programmable, definite time for ground currents below normal ground minimum trip levels. The feature has programmable operations to lockout and reclose intervals independent of the ground settings. This feature is independently selectable for each protection profile.

### Thermostatically controlled heater

The control includes a standard 15 (120 VAC) / 30 (240 VAC) Watt thermostatically controlled heater (ON 70 °F, OFF 85 °F) powered from 120 or 240 VAC input power. The heater is used for humidity control.

### Metering

The control provides instantaneous and/or demand metering with programmable integration intervals for the following functions:

- Real and reactive power for each phase and total, including directional, on an individual phase basis.
- Demand currents on a per phase basis.
- Instantaneous currents, including ground current.
- Instantaneous voltage on a per phase basis.
- Instantaneous frequency.
- Positive, negative, and zero sequence voltages.
- Instantaneous power factor on a per phase basis.
- Metering settings to include demand interval, and alarm thresholds for current, single-phase kW, three-phase kW, single-phase kvar, and three-phase kvar.

### Event recorder

The Form 6 control contains capabilities to perform Sequence of Events time-stamping for up to 69 event types. Sixteen additional inputs can be user-defined through the Idea Workbench.

Factory-defined event types include:

- Overcurrent Protection Trip
- External Trip
- Non-Reclose Trip
- External Close
- Lockout
- Reset

The Event Recorder maintains a minimum of 90 event records. The last 25 events are viewable on the front panel LCD display. Refer to *Service Information S280-70-9 (ProView 4.X.X)* or *S280-70-23 (ProView 5.X.X) Form 6-TS Control Programming Guide* for additional information.

### Recloser duty monitor

The Form 6 recloser control software is equipped with a Recloser Interrupting Duty Monitor. The Duty Monitor accumulates the summation of  $I^{1.5}$  for all interrupted currents on each interrupter. This feature permits programmable entries to preset the duty of an existing recloser. The recloser duty monitor displays interrupting duty in percent of duty used. If the duty cycle monitor exceeds 100%, the recloser should be examined for maintenance.

## Discrete SCADA communications

The control provides five configurable output status contacts and three configurable input control contacts as standard. Each status contact is configurable using graphical interface software to combine status functionality along with Boolean algebra. Default output status contacts are: AØ Lockout, AØ Recloser Open, AØ Recloser Closed, Ground Trip Block, and Hot Line Tag. One output status contact is a solid state output (SS1) with a pickup time no longer than two milliseconds.

The control also provides a minimum of three configurable input control contacts. Each control contact is configurable using ProView application software. Contacts accept a whetting voltage range of 9 VDC - 290 VDC, 7 VAC - 265 VAC based upon the option selected at time of order. Each digital input is configured for either a momentary, maintained, or maintained with precedence contact. Default input control contacts are Supervisory Trip and Lockout, Supervisory Close, and Remote Trip and Lockout.

A Discrete Interface Board is also available as an accessory to provide an additional eight output status contacts and eight input control contacts. The expansion I/O board is completely user-configurable.

## TCC Editor II

Coordination and actual time current modifications are available with a graphic interactive TCC Editor or similar graphical software.

The TCC Editor II includes a complete database of standard recloser industry time current curves (TCC), both ANSI and IEC types, along with the ability to customize the TCCs with multipliers, constant time adders, or minimum response time adders. Also, the user is able to derive their own specific TCC through data point entry. Each modified time current curve can be identified with a user-customized name and is selectable for configuring the control. The grid and format for presenting the TCCs has a user-adjustable scale, including the option of presenting multiple TCCs in various user-configured colors.

## Oscillography

Oscillography is provided to present current and voltage waveforms, along with protection element and recloser response status changes. Filtered and unfiltered data are provided for viewing.

The recorded values are super-imposed on the protection scheme, and the state or value at any point in the scheme is displayed. The user has the capability to move through the event and watch the response of every function. All analog signals, digital inputs, and contact outputs are monitored. Analog oscillography is displayed at 16 samples per cycle.

Oscillographic data is recorded to analyze multiple events during a permanent fault or other event type. The oscillographic data shows two cycles before the trigger point and eight cycles after the trigger point (default).

**Note:** The configuration settings are programmable.

Oscillography automatically initiates trigger points for the following functions:

- Above Minimum Trip for Phase, Ground, and Sensitive Ground Fault
- Single- and Three-Phase Overvoltage
- Single- and Three-Phase Undervoltage
- Over- and Underfrequency
- Trip Signal Issued
- Close Signal Issued

## Removable inserts

Removable inserts are included with the control design for customization of specific protection requirements. Inserts are available for the status indicator LEDs, the operator panel function keys, and the analysis keys. The removable inserts are designed for use without adhesives, labelmakers, or temporary labels.

An electronic label template is included on the ProView application software CD and can be accessed through the following default address: C:\Program Files\Cooper\ProviewXX\Form 6\Form 6 Inserts.doc.

Refer to **Using removable inserts** for more information.

## Idea workbench

The Idea Workbench provides access to various inputs, intermediate variables, and internal Form 6 alarms, status, and targets to allow user-customization of the Form 6 recloser control to meet specific and unique applications. Idea Workbench also gives the user the ability to perform logical functions with these variables by using a simple graphical user interface. Use of Idea Workbench is not a requirement for operation.

Refer to *Service Information S280-70-9 (ProView 4.X.X) or S280-70-23 (ProView 5.X.X) Form 6-TS Control Programming Guide* for additional Idea Workbench information.

## Over/underfrequency protection

The control includes two-stage operation for both underfrequency and overfrequency protection. A fixed time delay ranging from 0 to 100 seconds in .001 second increments is available for both over and underfrequency. A frequency restoration function, enabled or disabled by the user, is provided to allow the recloser to automatically close should frequency return to within configured settings for a user-settable time. Over/Underfrequency protection is included as part of each protection profile.

# Form 6 triple-single microprocessor-based yard mount recloser control

## Over/undervoltage protection

The control includes single-phase and three-phase undervoltage tripping. The control also includes three-phase overvoltage tripping. Both over and undervoltage functions include a single-phase and three-phase pick-up setting; a single-phase and three-phase time delay setting ranging from 0 to 100 seconds.

## Directional

Directional functionality is included to maintain system coordination from multiple sources, as well as circuit reconfiguration for each profile. Directional applies to phase, ground, and negative sequence protection, selected independently. A maximum torque angle has a range of 0 – 90 degrees.

## Fault location

The control includes an impedance-based fault locator based upon the Takagi algorithm<sup>1</sup>. Load-compensated impedance calculation is used for calculating the distance. Positive and zero sequence is configured in ohms, and the fault locator line length is configured in kilometers/miles.

<sup>1</sup>T. Takagi, Y. Yamakoshi, J. Baba, K. Uemura, T. Sakaguchi, "A New Algorithm of an Accurate Fault Location for EHV/UHV Transmission Lines: Part I - Fourier Transformation Method"; IEEE Trans. on PAS, Vol. PAS-100, No. 3, March 1981, pp 1316-1323.

## Sync check

Sync Check is a permissive system used to qualify any close signal to the mechanism when enabled via the sync check settings. Sync check allows for closing for any combination of dead/live bus/line, and to perform anticipatory closing for a live bus/live line condition by calculating slip and anticipating the mechanism closing delay. In addition to the anticipatory close calculation, the sync check system performs verification of line and bus voltage magnitudes and frequencies to determine that they are within pre-determined ranges, and that the angular difference between the two systems is also within the pre-determined range. For a live/live close, where there is no slip between the systems, the sync check system allows permissive closing after the two systems are within frequency and voltage limits, and the angular difference between the systems has been within the allowable limits for a pre-determined time.

Sync Check functionality includes the following applications: Hot Line/Hot Bus Closing; Dead Line/Hot Bus Closing; Hot Line/Dead Bus Closing; and Dead Line/Dead Bus Closing.

Sync Check Parameters include the following configurable settings: Voltage Angle; Mechanism Operating Delay; Static Angle Delay; Dead Threshold; Live Threshold; Positive Sequence Dead Threshold; Upper Voltage Limit; Lower Voltage Limit; Lower Frequency Limit; Upper Frequency Limit; and Fail to Close Timer.

## Data profiler

A fully-configurable data profiler is available which allows the user to collect information by sampling data at selectable intervals. These time-stamped values can then be viewed to determine weekly load profiles, daily harmonic disturbances or hourly voltage fluctuations. The number of days of information the data profiler can provide depends upon configuration parameters.

Refer to *Service Information S280-70-9 (ProView 4.X.X) or S280-70-23 (ProView 5.X.X) Form 6-TS Control Programming Guide* for additional information.

## Manual close delay

Manual Close Delay provides a delay from the time that the manual CLOSE button is pushed to the time the manual close operation is performed.

The delay is programmable from 0 to 60 seconds in 1 second increments. A programmed delay value can be overridden for immediate closing by pressing the CLOSE button a second time.

An active Manual Close Delay can be canceled by pressing the TRIP/LOCKOUT button.

The default setting has the feature disabled (0 seconds). A countdown on the front panel LCD screen indicates Manual Close Delay is active.

## Communications

### Communication ports

The Form 6-TS control has two back panel communication ports and a front panel configuration data port.

The front panel configuration data port is described in the **Operating panel** section of this manual.

There is one standard 9-pin RS-232 and one optional communication port (RS-485, serial fiber, Ethernet wire or fiber or both) on the back operator panel, as well as a standard IRIG-B port for user time-syncing. See **Figure 7**.

### Communication protocols

Three communication protocols are available for the Form 6-TS recloser control:

- Modbus
- DNP3
- 2179

One communication protocol can be selected for either the back panel RS-232 or the optional communication port.

All three protocols are selected and configured by the user with the ProView Communications Workbench application software.



**Ethernet communications**

- ProView over TCP/IP
- DNP3 over TCP/IP

Ethernet connection allows for network application of the Form 6-TS control for both DNP3 and ProView protocols. In addition, the front panel data port can simultaneously communicate ProView to the PC.

Ethernet configuration is accomplished via ProView interface software. Refer to *Service Information S280-70-9 (ProView 4.X.X) or S280-70-23 (ProView 5.X.X) Form 6-TS Control Programming Guide, Section 4: Schemes, Communicating with the Form 6 Control*, for Ethernet Configuration information.

When a communication protocol is selected for the optional communication boards (serial fiber or the RS-485 serial port), the RS-232 serial port is defaulted to ProView interface software protocol.

DNP3 is factory-defaulted to the RS-232 port.

When a communication protocol is selected for the RS-232 serial port, the optional RS-485 or serial fiber optic board is not active.

The RS-485 or fiber optic serial ports do not support ProView interface software protocol.

The user can simultaneously communicate to the Form 6-TS control using both the front panel data port and the appropriate back panel serial communication port (provided the back panel RS-232 port or the Ethernet optional communications board is not configured to be ProView protocol).

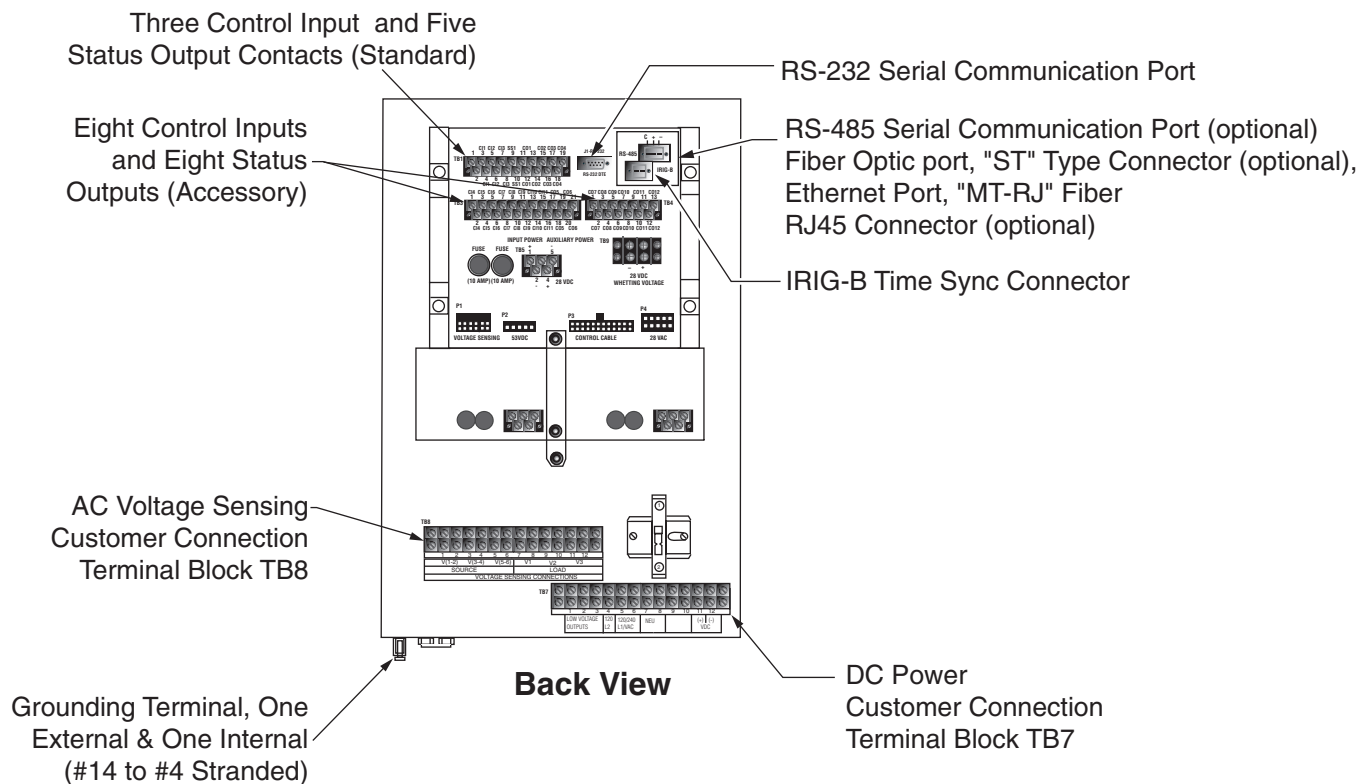

**Figure 7. Form 6-TS yard mount recloser control back panel**

**Control information**

Control information includes firmware identification by catalog number and name, date code, and ProView release number. Control information is available through the Settings menu on the front panel (Figure 2).

**Control back panel**

The control back panel is easily accessible through the back door of the control cabinet (Figure 8) with readily identifiable communication ports and connections (Figure 7).

## Installation procedure

### Initial programming prior to installation

**CAUTION**

Equipment misoperation. Do not connect this control to an energized recloser until all control settings have been properly programmed and verified. Refer to the programming information for this control. Failure to comply can result in control and recloser misoperation, equipment damage, and personal injury. G110.3

**IMPORTANT**

Equipment misoperation. Check minimum trip values prior to changing an alternate profile. Failure to do so may cause misoperation of the recloser under load conditions. T280.1

**IMPORTANT**

Program all protection profiles. Unused alternate profiles should be programmed with the same settings as one of the applicable profiles. Default settings on unused alternate profiles can cause unnecessary outages if they are below normal system requirements.

The control must be programmed with all necessary operating settings, all alternate profiles, and parameters prior to operation with an energized recloser.

**Note:** Initial programming of the control is the responsibility of a qualified technician or engineer familiar with control functions and programming parameters required for the specific recloser installation.

The control must be programmed with the Form 6 ProView interface software. Refer to *Service Information S280-70-9 (ProView 4.X.X)* or *S280-70-23 (ProView 5.X.X) Form 6-TS Control Programming Guide* for additional information.

### Control / recloser compatibility

The Form 6-TS rack-mount recloser control is only compatible with the NOVA-TS and NOVA STS reclosers. Refer to the appropriate recloser instructions for additional information:

- *Service Information MN280045EN NOVA-TS Recloser Installation and Operation Instructions*
- *Service Information MN280046EN NOVA STS Recloser Installation and Operation Instructions*



**Figure 8. Form 6-TS yard mount recloser control is accessible from both the front and back of the cabinet**

### Duty cycle monitor

The Duty Cycle Monitor provides the following duty cycle information:

- Measures and records duty for each individual phase in non-volatile memory.
- The recloser duty is measured and stored on the basis of  $Current^{1.5} \times Number\ of\ Operations\ for\ Each\ Phase$  (ANSI C37.61).
- Readout is based on a percentage of total duty cycle used for each phase.
- Duty record can be adjusted or reset if recloser is changed-out, serviced, etc.

Using **Table 1**, select the appropriate NOVA-TS recloser interrupting duty cycle factor and enter that value via the ProView interface software.

**Table 1. Duty cycle factor**

Recloser type	Interrupting rating (RMS SYM AMPS)	100% duty cycle factor*
NOVA-TS-8	8,000	568
NOVA STS-8	8,000	568
NOVA-TS-12	12,500	1111
NOVA STS-12	12,500	1111
NOVA-TS-16	16,000	1608
NOVA STS-16	16,000	1608

\*Duty Cycle Factor is Value x 10<sup>5</sup>.

### Control cable

#### **WARNING**

**Hazardous voltage. Recloser and control must be solidly grounded. Follow all approved procedures and safety practices when grounding this equipment. Improper grounding can result in contact with high voltage, which will cause death or severe personal injury.** G115.1

- The maximum control cable length between the Form 6-TS yard-mount control and the NOVA-TS triple-single junction box is 50 feet.
- The maximum control cable length between the Form 6-TS yard-mount control and the NOVA STS recloser is 80 feet.

**Note:** The control cable must be supported along its length to prevent repeated movement due to wind or other outside forces which can damage the cable.

#### **IMPORTANT**

All external inputs to the Form 6 recloser control must be routed within 8 inches of their corresponding ground. During a surge, a potential of approximately 1.5 kV per foot can develop in the conductors. Differences between conductor and ground path lengths can add additional stress to the control components in the event of a power surge.

### NOVA-TS junction box and cables

The Type NOVA-TS Triple-Single recloser is connected to the Form 6-TS recloser control at a junction box. See **Figure 9**.

**Note:** The NOVA STS recloser does not use a junction box for connection to the control. The NOVA STS recloser and Form 6-TS/LS control are directly connected via a control cable.

The maximum junction box cable length between the triple-single junction box and the NOVA-TS recloser is (9.14 meters) 30 feet. Three junction box cables are required - one for each recloser.

The junction box is mounted on the substation frame between the Type NOVA-TS Triple-Single recloser(s) and the Form 6-TS yard mount control.

#### **IMPORTANT**

The triple-single recloser junction box is mounted with all cable connections made at the bottom of the box. Do not invert.

### Reclose times

Assuming the following conditions, the reclose times for the Form 6-TS yard mount control are as follows:

#### NOVA-TS recloser(s)

- Junction Box Cables (3) Length: 9.15 meters (30 feet) between the junction box and the three NOVA-TS reclosers.

- Control Cable Length: 15.24 meters (50 feet) between the Form 6-TS yard mount control and the junction box.

#### NOVA STS recloser

- Control Cable Length: 24.39 meters (80 feet) between the Form 6-TS yard mount control and the NOVA STS recloser.

**Temperature:** -40 °C (-40 °F) for all equipment

**Reclose Times:**

1st	2.0 seconds
2nd	2.0 seconds
3rd	2.0 seconds

### Mounting the control

#### **WARNING**

**This equipment is not intended to protect human life. Follow all locally approved procedures and safety practices when installing or operating this equipment. Failure to comply can result in death, severe personal injury, and equipment damage.** G102.1

#### **WARNING**

**Falling equipment. Use the lifting lugs provided and follow all locally approved safety practices when lifting and mounting the equipment. Lift the unit smoothly and do not allow the unit to shift. Improper lifting can result in severe personal injury, death, and/or equipment damage.** G106.3

Mount the Form 6-TS yard mount recloser control in a convenient, accessible location in a substation yard. Mounting dimensions are provided in **Figure 10**.

**Note:** Unless otherwise specified, dimensions shown in mm (inches).

A hole and keyway in the control mounting bracket accommodates a 15.9 mm (5/8") bolt.

The weight of one Form 6-TS yard mount control is approximately 34 kg (75 lbs).

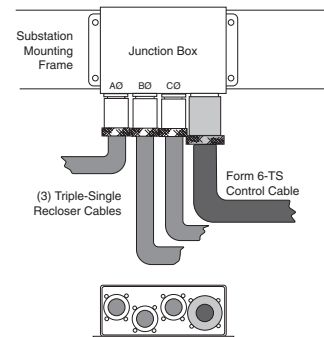

**Figure 9. NOVA-TS Triple-Single reclosers are connected to the Form 6-TS control through a junction box**

# Form 6 triple-single microprocessor-based yard mount recloser control

## Locking the control

The handles on the Form 6 control cabinet are able to accept a padlock to prevent unauthorized access. For cabinets with the quarter-turn latch, the top handle has two locking holes provided depending on the diameter of the lock shackle being used. Refer to **Figure 10**.

- Use the smaller hole for shackle diameters of .177–.295"
- Use the larger hole for shackle diameters of .295–.394"

**Note:** DO NOT use a smaller shackle (.177–.295) in the larger diameter hole as it will NOT LOCK the cabinet.

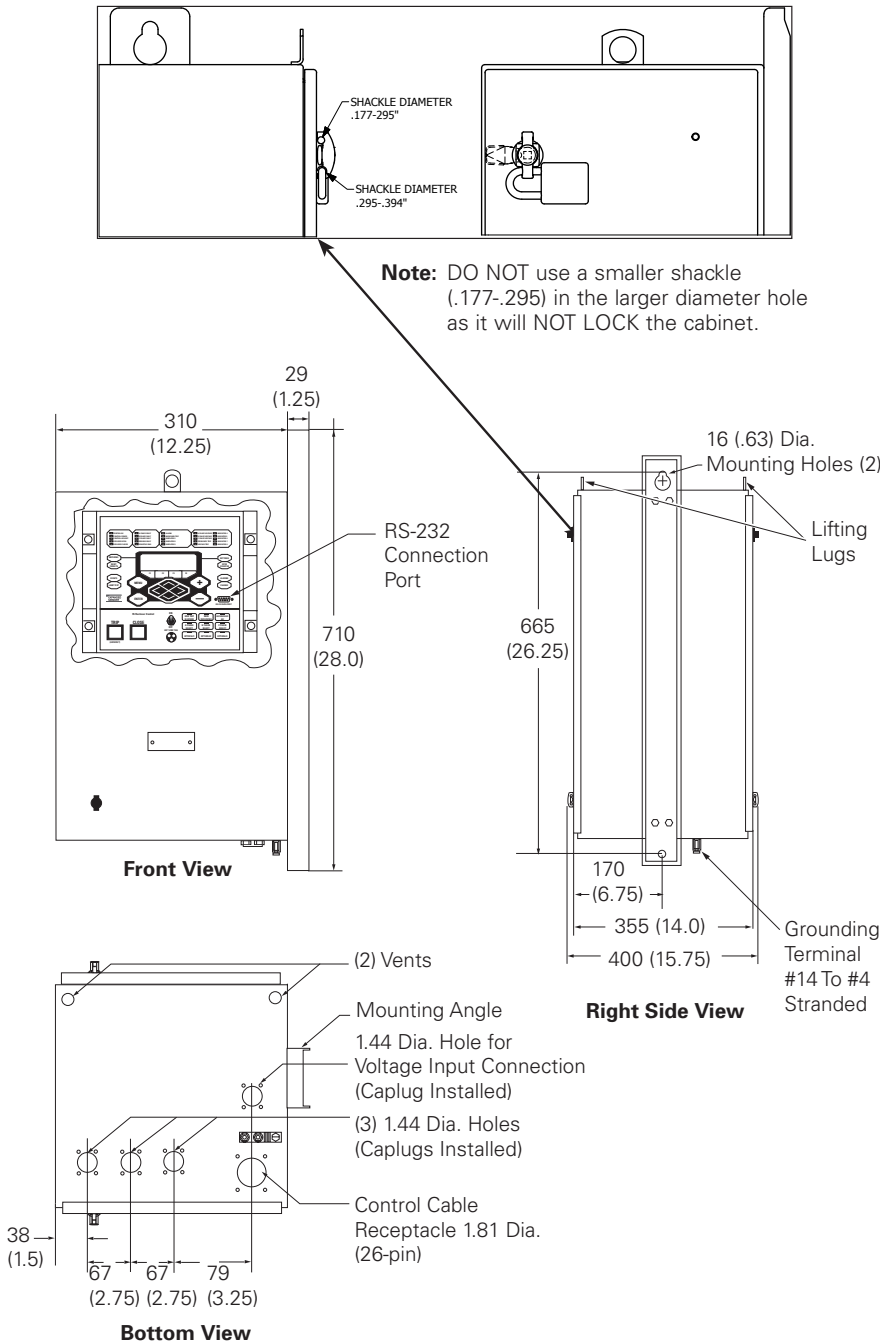

**Figure 10. Form 6-TS yard mount recloser control dimensions and pad-lock shackle diameters**

**Grounding the control**

**WARNING**

**Hazardous voltage. Recloser and control must be solidly grounded. Follow all locally approved procedures and safety practices when grounding this equipment. Improper grounding can result in contact with high voltage, which will cause death or severe personal injury.**

G115.1

The Form 6-TS yard mount recloser control must be solidly grounded prior to installation or energization. Refer to **Figure 11** for grounding connections.

**Note:** Control grounding must comply with all locally approved procedures and safety practices that apply in a substation yard.

**IMPORTANT**

All external inputs to the Form 6 recloser control must be routed within 8 inches of their corresponding ground. During a surge, a potential of approximately 1.5 kV per foot can develop in the conductors. Differences between conductor and ground path lengths can add additional stress to the control components in the event of a power surge.

The control cabinet must be grounded. A grounding connector on the underside of the cabinet will accommodate No. 14 solid through No. 4 stranded conductors.

The triple-single recloser(s) that the control will be connected to must also be properly grounded.

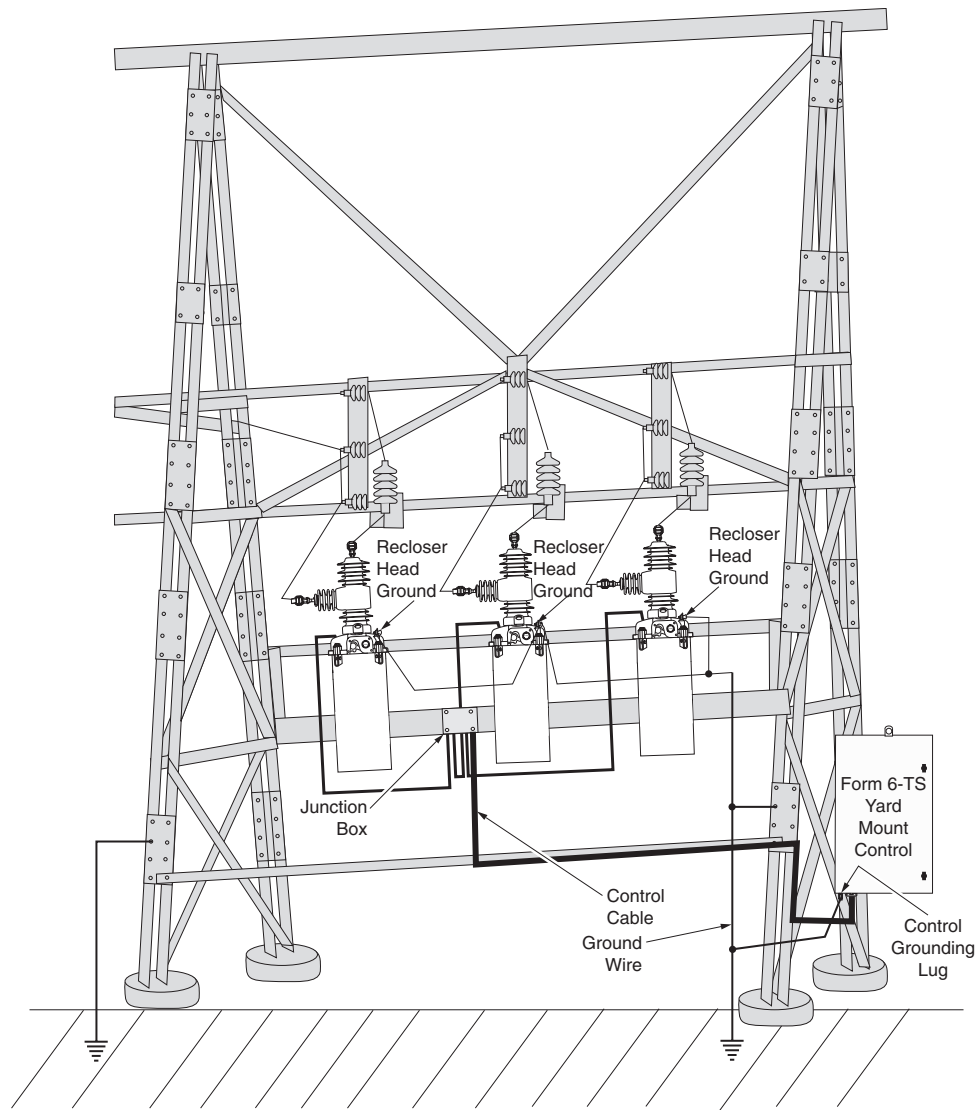

**Figure 11. Grounding connections for a Form 6-TS yard mount control installed in a substation**

# Form 6 triple-single microprocessor-based yard mount recloser control

## Customer connections for DC power and AC voltage sensing

### ⚠ DANGER

**Hazardous voltage. Do not connect potential transformer low-voltage secondaries to the control through cables or other wiring until the unit is installed in the field. Transformer high-voltage primary windings will become live when 120/240 VAC is applied to the control from an alternate source if the transformer secondary is connected. Failure to comply may result in severe personal injury or death.**

T371.2

### ⚠ WARNING

**Hazardous voltage. Before applying power to the control, confirm that male pins of the input power receptacle are electrically insulated to prevent unintentional contact with 120/240 VAC voltage. Failure to do so may result in severe personal injury or death.**

T372.1

### NOTICE

**Equipment damage. Do not drill connection holes into the top of the cabinet. Connection holes in the top of the cabinet will allow moisture to seep into the control and damage the components or cause control misoperation. Failure to comply will void the control's factory warranty.**

T249.0

### DC power

Input power to the Form 6-TS yard mount recloser control is connected to terminal block TB7 (Figure 12), which is located in the lower-right corner of the cabinet. Input DC power is required to power the control and recloser. The control requires DC station supply service for the main power requirements of both the control and the recloser.

The control requires the correct DC power supply for proper operation with the DC substation battery. The control has one power supply option based upon the following voltage range:

- 40 –140 VDC

### IMPORTANT

Verify the label on the Form 6-TS yard mount recloser control matches the voltage of the substation supply prior to installation.

DC power is connected to terminal block TB7, terminal positions 11(+) and 12(-).

**Note:** The label at TB7-11 and TB7-12 will display the input power option (48/125 VDC).

### IMPORTANT

Substation battery negative is not grounded in the control.

The control should be grounded per the information in the **Grounding the control** section.

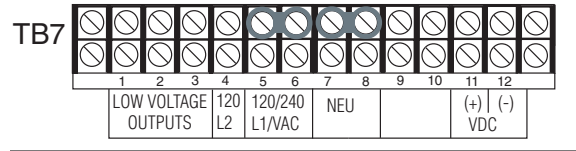

**Figure 12. Power connections terminal block TB7**

### AC voltage sensing

AC power is required:

- To provide voltage and power metering
- For the convenience outlet accessory
- To power the thermostatically controlled heater

AC voltage input connections are connected to TB8 for Wye connections only. Figure 13 illustrates three-phase wiring connections for both source and load side connections.

The AC voltage inputs for both source or load side accept 120/240 VAC nominal. For single-phase source side AC voltage inputs, connections to AØ, BØ, or CØ are acceptable. The default wiring is connected to BØ.

### Terminal blocks

Two terminal blocks are used for connection to the Form 6-TS recloser control. Both terminal blocks are fit for a #6 screw which can allow a maximum terminal size for a #10 AWG wire size.

Terminal Block TB7 provides DC power to the Form 6-TS recloser control and is directly connected to the power supply circuit board. TB7 is also used to provide AC voltage inputs for the heater. (TB7-5 is hot. TB7-7 is neutral.) Terminal Block TB8 is used to connect sensing transformer voltage. The wiring of the transformers should follow the application illustrations per Figure 13 and Figure 14.

For 240 Volt, 3-wire transformer connection refer to Figure 15.

Default factory wiring includes connection of two wires from Power Supply Terminal Block TB7 to the Metering Terminal Block TB8. See Figure 16.

The wiring from TB7-5 to TB8-3 and from TB7-7 to TB8-4 connects the sensing B phase voltage. If the incoming sensing voltage is not the B phase voltage, the lead wire needs to be moved to the appropriate location. See Figure 17 for A phase connections.

For A phase voltage sensing only, connect to TB8-1.

For C phase voltage sensing only, connect to TB8-5.

**Note:** Terminal Block positions TB7-5 and TB7-6 are factory-jumpered together.

Terminal Block positions TB7-7 and TB7-8 are factory-jumpered together.

Figure 18 shows customer connections to TB8, 120 VAC Delta connection.

**AC power requirements**

The transformer required for power is a minimum of 1 kVA.

**Note:** AC voltage is required for the internal cabinet heater and the 120 VAC GFI Duplex Outlet accessory.

The following are not functional for single phase AC voltage input:

- Directional Protection
- Single-Phase Voltage Protection
- True Three-Phase Metering

**Note:** Phantom Phase can generate missing phases for three-phase metering estimates.

**⚠ DANGER**

**Hazardous voltage. Do not connect potential transformer low-voltage secondaries to the control through cables or other wiring until the unit is installed in the field. Transformer high-voltage primary windings will become live when 120/240 VAC is applied to the control from an alternate source if the transformer secondary is connected. Failure to comply may result in severe personal injury or death.**

T371.2

**⚠ WARNING**

**Hazardous voltage. Before applying power to the control, confirm that male pins of the input power receptacle are electrically insulated to prevent unintentional contact with 120/240 VAC voltage. Failure to do so may result in severe personal injury or death.**

T372.1

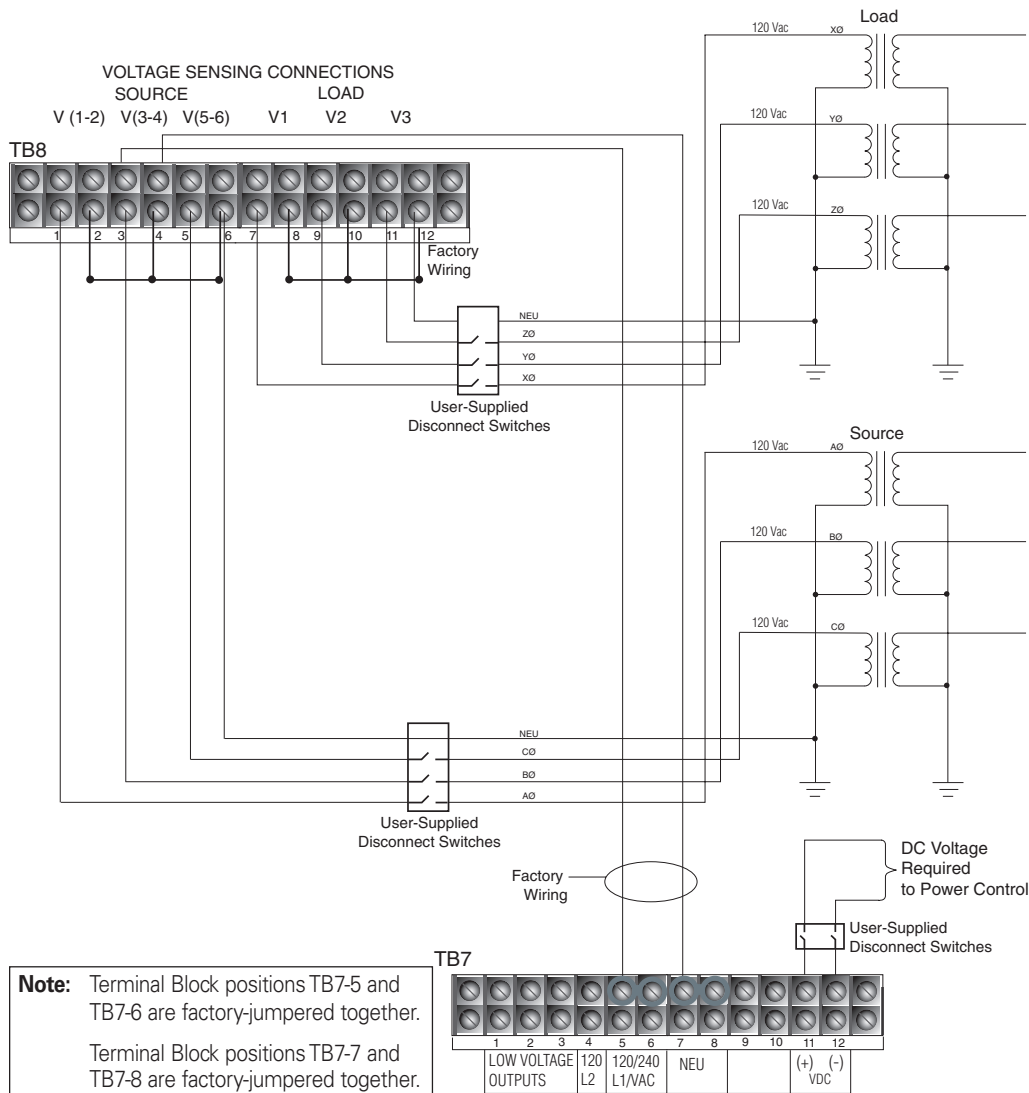

**Figure 13. Three-Phase transformer connection for voltage sensing and heater, wye configuration only (TB8 terminal block connection)**





**⚠ DANGER**

**Hazardous voltage. Do not connect potential transformer low-voltage secondaries to the control through cables or other wiring until the unit is installed in the field. Transformer high-voltage primary windings will become live when 120/240 VAC is applied to the control from an alternate source if the transformer secondary is connected. Failure to comply may result in severe personal injury or death.**

T371.2

**⚠ WARNING**

**Hazardous voltage. Before applying power to the control, confirm that male pins of the input power receptacle are electrically insulated to prevent unintentional contact with 120/240 VAC voltage. Failure to do so may result in severe personal injury or death.**

T372.1

**Note:** Terminal Block positions TB7-5 and TB7-6 are factory-jumpered together.

Terminal Block positions TB7-7 and TB7-8 are factory-jumpered together.

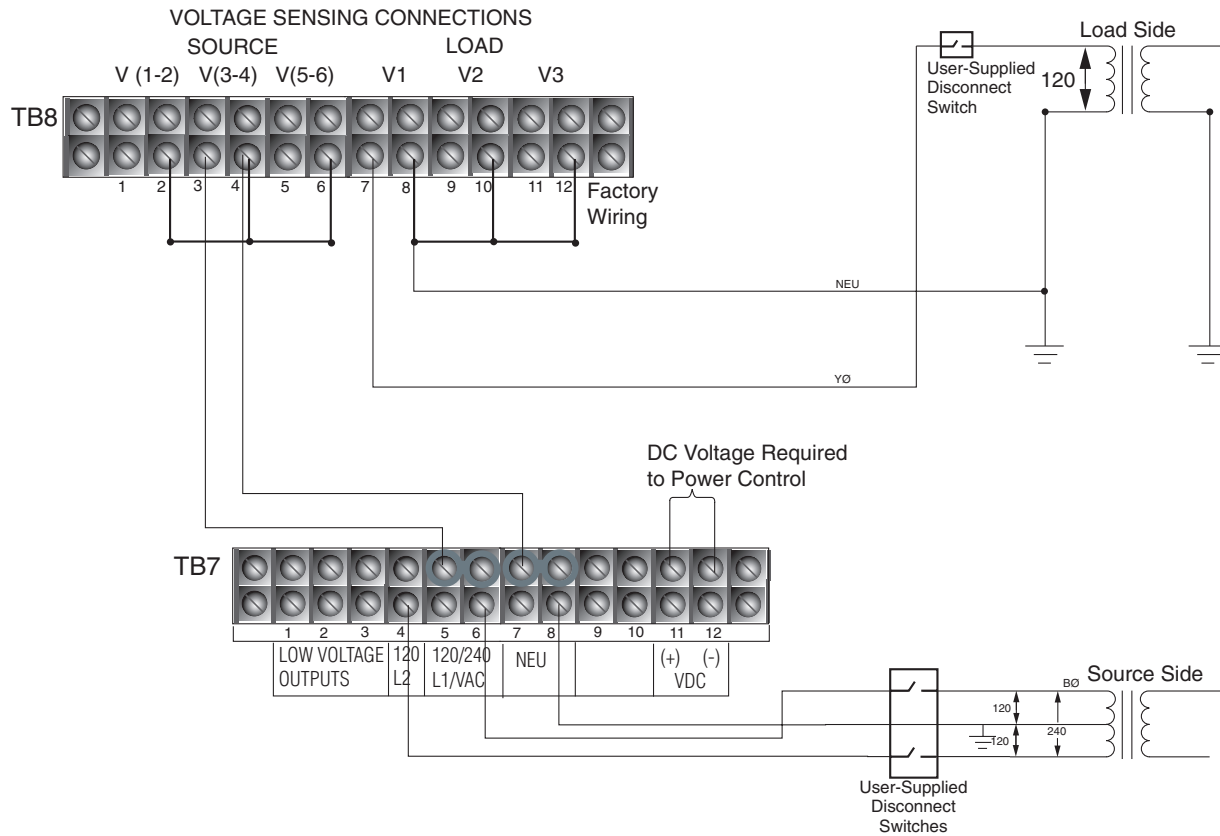

**Figure 15. 240 Volt, 3-wire transformer connection for voltage and sensing on B-Phase. Y0 for sync check voltage**





## Form 6 triple-single microprocessor-based yard mount recloser control

### **⚠ DANGER**

**Hazardous voltage. Do not connect potential transformer low-voltage secondaries to the control through cables or other wiring until the unit is installed in the field. Transformer high-voltage primary windings will become live when 120/240 VAC is applied to the control from an alternate source if the transformer secondary is connected. Failure to comply may result in severe personal injury or death.**

T371.2

### **⚠ WARNING**

**Hazardous voltage. Before applying power to the control, confirm that male pins of the input power receptacle are electrically insulated to prevent unintentional contact with 120/240 VAC voltage. Failure to do so may result in severe personal injury or death.**

T372.1

**Note:** Terminal Block positions TB8-1 and TB8-6 are factory-jumpered together.

Terminal Block positions TB8-2 and TB8-3 are factory-jumpered together.

Terminal Block positions TB8-4 and TB8-5 are factory-jumpered together.

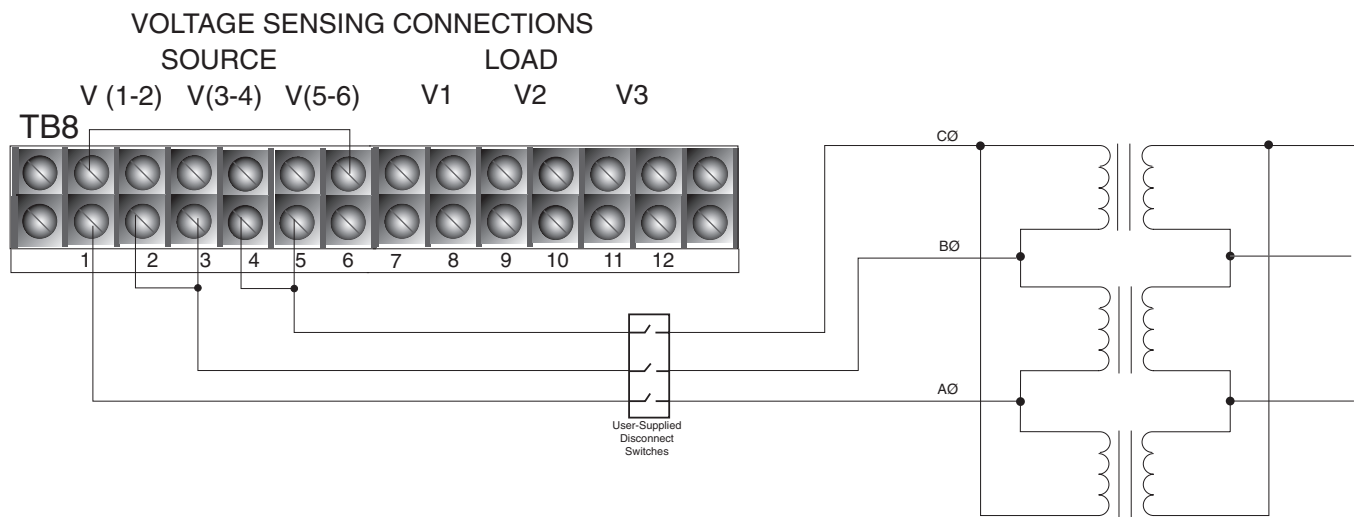

**Figure 18. Customer connections to TB8, 120 VAC delta connection**

### **Before placing the control and the recloser into service**

### **⚠ CAUTION**

**Equipment misoperation. Do not connect this control to an energized recloser until all control settings have been properly programmed and verified. Refer to the programming information for this control. Failure to comply can result in control and recloser misoperation, equipment damage, and personal injury.**

G110.3

Prior to placing the control and recloser into service, the following installation procedures must be properly completed and verified:

1. Removable insert labels changed. (Not required – user-preference option.)

**Note:** Refer to **Using removable inserts** section in this manual for more information.

2. Control properly mounted for the installation.
3. Triple-single reclosers mounted and installed according to all locally approved standards and practices.

4. AC and DC disconnect switches installed.
5. Control wiring between control and recloser properly connected and supported.
6. Control and reclosers properly grounded in accordance with guidelines in this manual and the appropriate recloser manual.
  - *Service Information MN280045EN NOVA-TS Recloser Installation and Operation Instructions*
  - *Service Information MN280046EN NOVA STS Recloser Installation and Operation Instructions*
7. DC power and AC voltage sensing connected to the control.

**Note:** The control Power Save feature will turn off the backlit LCD display and all LEDs if no front panel keypad is pressed within ten minutes.

8. All control programming entered and verified by appropriate personnel.

**Note:** Refer to Service Information S280-70-9 (ProView 4.X.X) or S280-70-23 (ProView 5.X.X) Form 6-TS Control Programming Guide for additional information.

- Customer connections for remote and supervisory operation checked and completed in accordance with proper shielding and surge protection.

**Standard default supervisory input control and output status contacts**

The standard Form 6-TS yard mount recloser control includes three control contact inputs and five status contact outputs. The standard default I/O terminal connections are identified in **Figure 19**. A discrete interface board accessory is available if additional I/O is required. The accessory includes eight control contact inputs and eight status outputs as identified in **Figure 20**.

All of the control inputs and status outputs are user-configurable via the Idea Workbench. To avoid configuration time, the most common control inputs and status outputs are included as default values. Refer to *Service Information S280-70-9 (ProView 4.X.X)* or *S280-70-23 (ProView 5.X.X) Form 6-TS Control Programming Guide* for additional information.

**NOTICE**

**External leads must be shielded and the shield must be grounded at both ends. Terminate each lead with a 320 VAC, 150 Joules metal oxide varistor (MOV), or equivalent, at the remote end. Attach MOVs between the leads and ground. Failure to properly shield and protect leads can result in equipment damage and/or unintentional operation.**

**IMPORTANT**

**Shielding and Surge Protection of Supervisory Cables**

All supervisory operation and control monitor leads must be protected within shielded cables. Refer to **Figure 21** (factory-supplied whetting voltage) or **Figure 22** (customer-supplied whetting voltage).

**Table 2. Operating whetting voltage and current requirements for the standard (TB1) and accessory (TB3) discrete interface boards**

Input voltage	Nominal current	Minimum operating time
9 VDC – 290 VDC,		
7 VAC – 265 VAC	2.5 mA	5 milliseconds

**Table 3. Ratings table for output status contacts CO1 through CO12 (TB1, TB3, and TB4) (resistive load – pickup time 8 ms, dropout 5 ms)**

Input voltage	Contact rating
120 VAC	8 A
12 VDC	8 A
24 VDC	8 A
48 VDC	1 A
125 VDC	0.4 A

**Table 4. Ratings table for output status contact SS1 (Resistive load – pickup time 2 ms, dropout 15 ms) (TB1)**

Input Voltage	Contact Rating
120 VAC	8 A
12 VDC	8 A
24 VDC	8 A
48 VDC	8 A
125 VDC	8 A

**NOTICE**

**External leads must be shielded and the shield must be grounded at both ends. Terminate each lead with a 320 VAC, 150 Joules metal oxide varistor (MOV), or equivalent, at the remote end. Attach MOVs between the leads and ground. Failure to properly shield and protect leads can result in equipment damage and/or unintentional operation.**

**IMPORTANT**

**Shielding and Surge Protection of Supervisory Cables**

All supervisory operation and control monitor leads must be protected within shielded cables. Refer to **Figure 21** (factory-supplied whetting voltage) or **Figure 22** (customer-supplied whetting voltage).

# Form 6 triple-single microprocessor-based yard mount recloser control

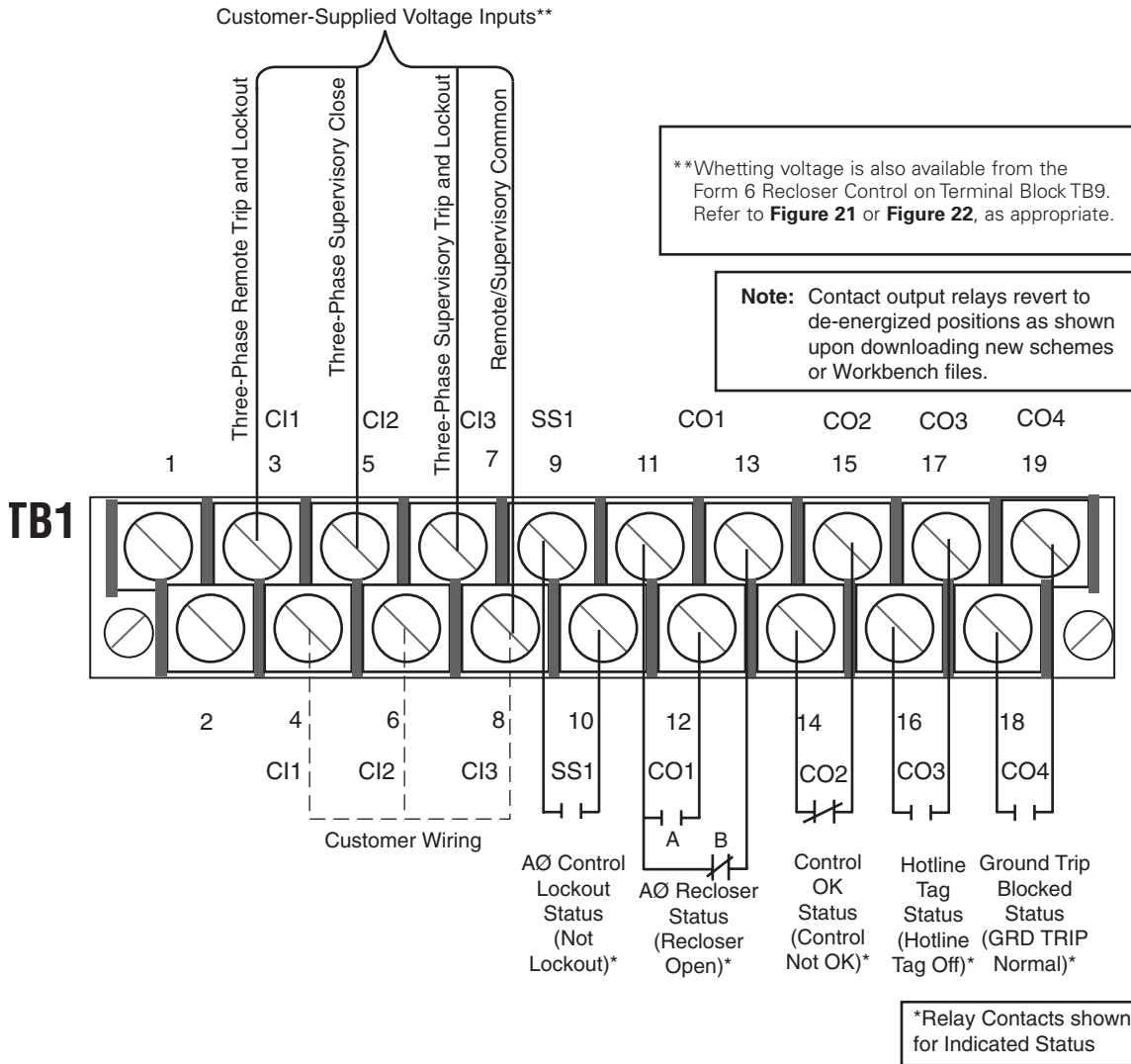

**Figure 19. Form 6-TS yard mount recloser control Standard discrete interface board and default configurations. These default contact input/outputs are completely configurable via the Idea Workbench**

**NOTICE**

External leads must be shielded and the shield must be grounded at both ends. Terminate each lead with a 320 VAC, 150 Joules metal oxide varistor (MOV), or equivalent, at the remote end. Attach MOVs between the leads and ground. Failure to properly shield and protect leads can result in equipment damage and/or unintentional operation.

**IMPORTANT**

**Shielding and Surge Protection of Supervisory Cables**

All supervisory operation and control monitor leads must be protected within shielded cables. Refer to **Figure 21** (factory-supplied whetting voltage) or **Figure 22** (customer-supplied whetting voltage).

\*\*Whetting voltage is available from the Form 6 Recloser Control on Terminal Block TB9. Refer to **Figure 21** or **Figure 22**, as appropriate.

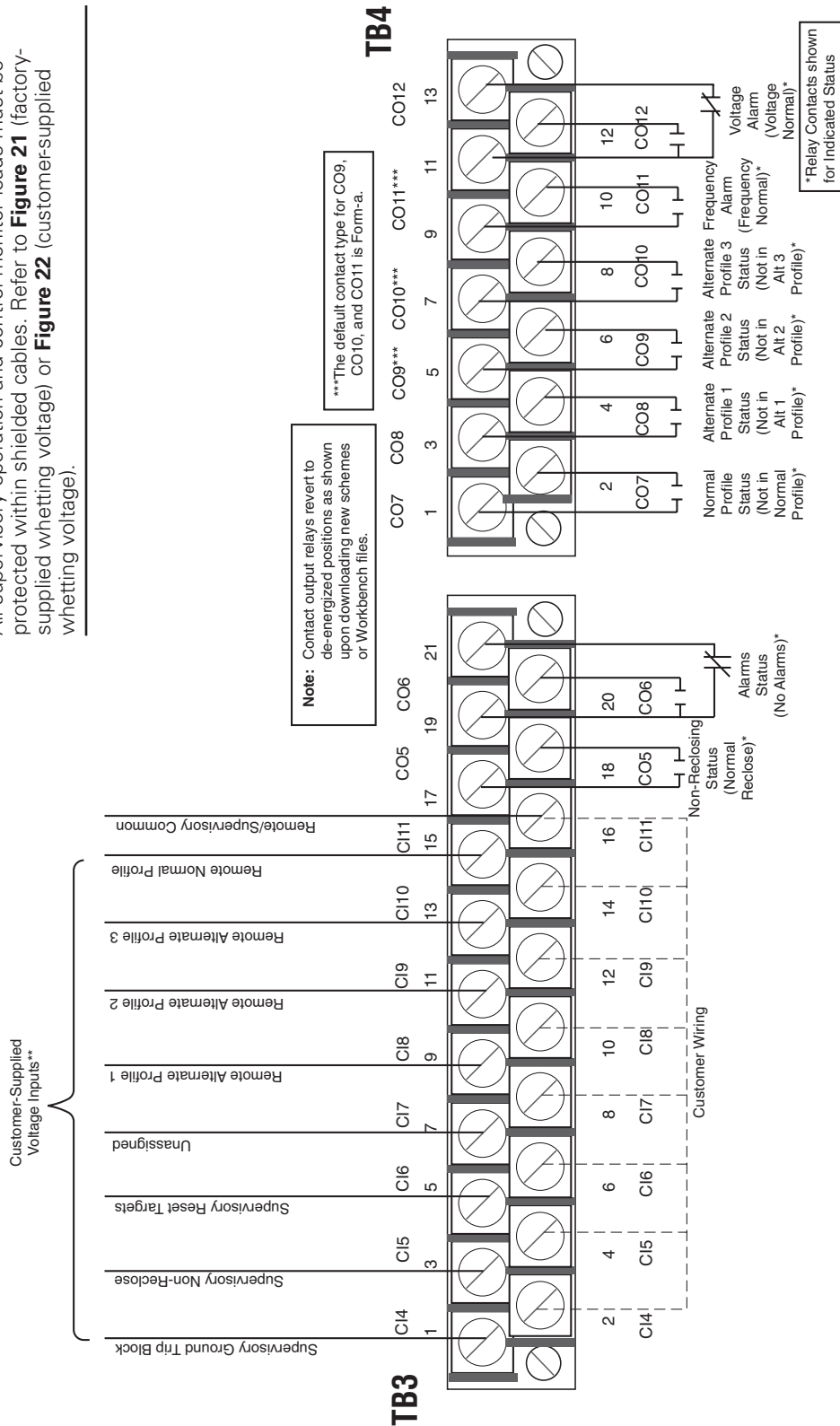
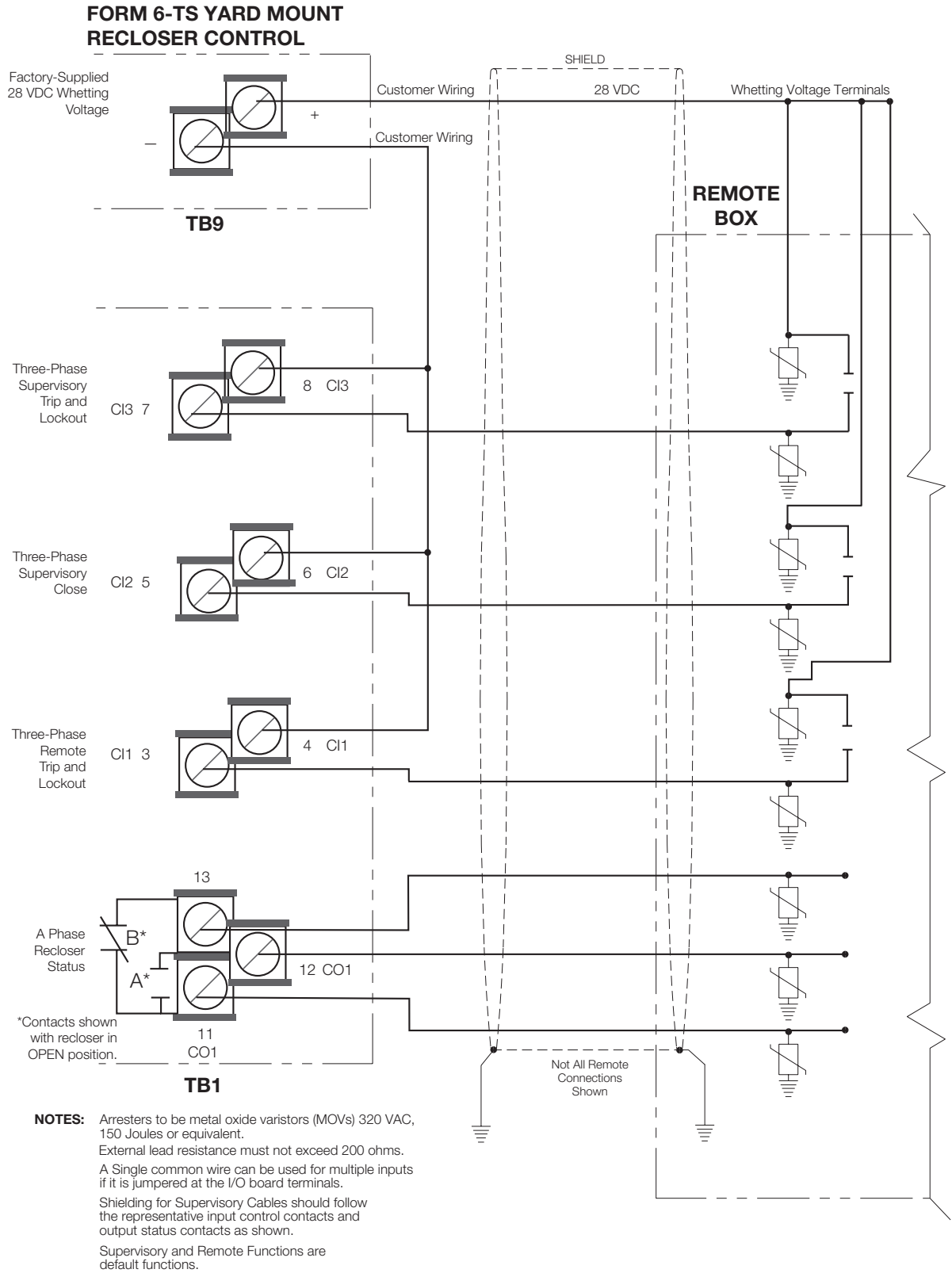

Figure 20. Form 6-TS yard mount recloser control discrete interface board accessory and default configurations. These default contact input/outputs are completely configurable via the idea workbench

# Form 6 triple-single microprocessor-based yard mount recloser control



**Figure 21. Shielding and surge protection for supervisory and remote cables (factory-supplied whetting voltage)**



**NOTES:** Arresters to be metal oxide varistors (MOVs) 320 VAC, 150 Joules or equivalent.  
 External lead resistance must not exceed 200 ohms.  
 A Single common wire can be used for multiple inputs if it is jumpered at the I/O board terminals.  
 Shielding for Supervisory Cables should follow the representative input control contacts and output status contacts as shown.  
 Supervisory and Remote Functions are default functions.

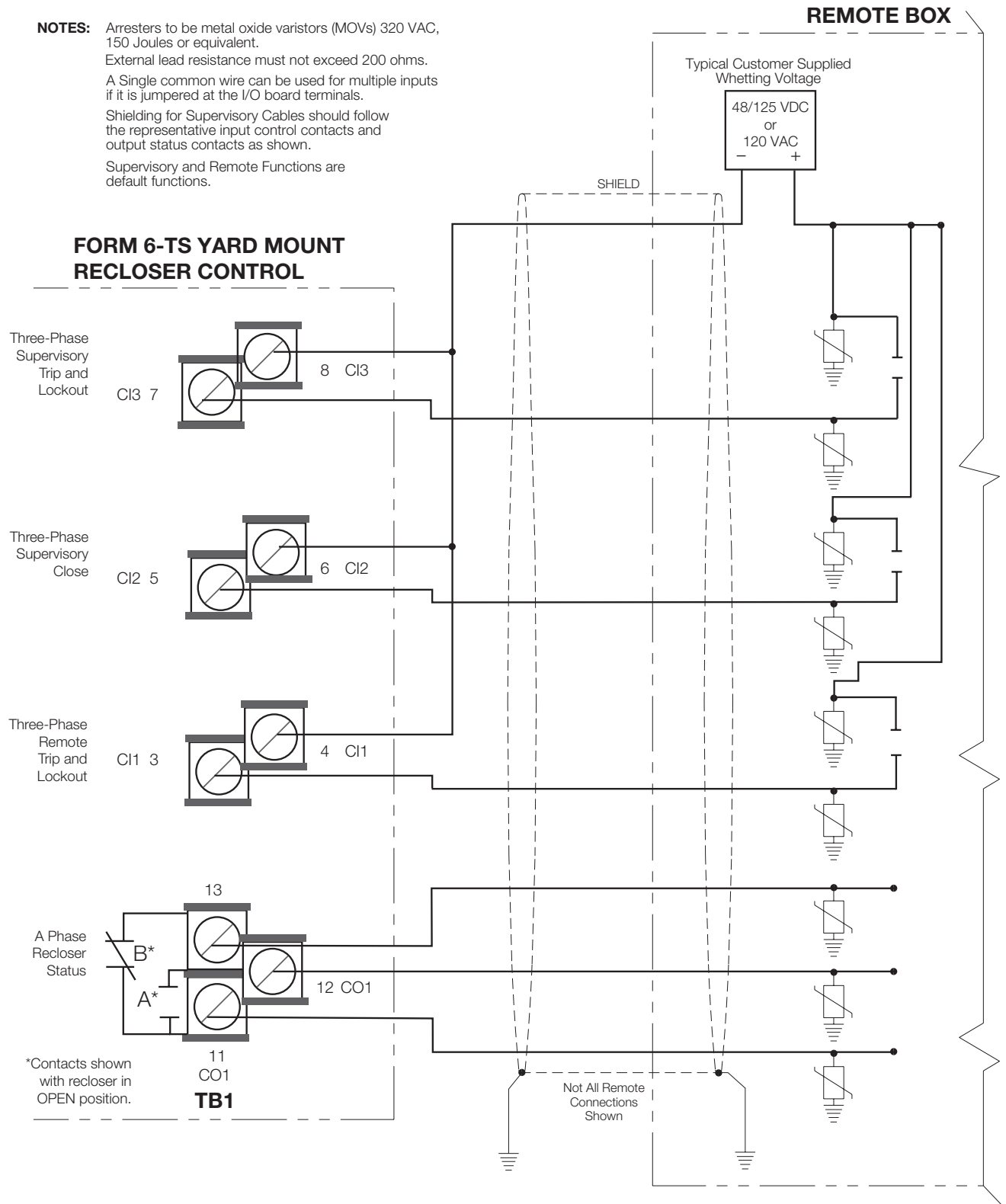

Figure 22. Shielding and surge protection for supervisory and remote cables (customer-supplied whetting voltage)

## Form 6 triple-single microprocessor-based yard mount recloser control

### Rear panel RS-232 communication port pin assignments

Table 5 indicates the pin assignments for the rear panel RS-232 communication port (Figure 23). Refer to Figure 24 for pin identification. Refer to **Communication protocols** for additional information.

Refer to the **Accessories** section of this manual for additional communication options.

**Table 5. Rear panel RS-232 communication port pin assignments**

Pin number	Signal name
1 DCD	Carrier Detect
2 RXD	Receive Data
3 TXD	Transmit Data
4 DTR	Data Terminal Ready (Not Connected)
5 GND	Signal Ground
6 DSR	Data Set Ready (Not Connected)
7 RTS	Request to Send
8 CTS	Clear to Send
9 NC	Not Used
10 (Shroud)	Chassis Ground

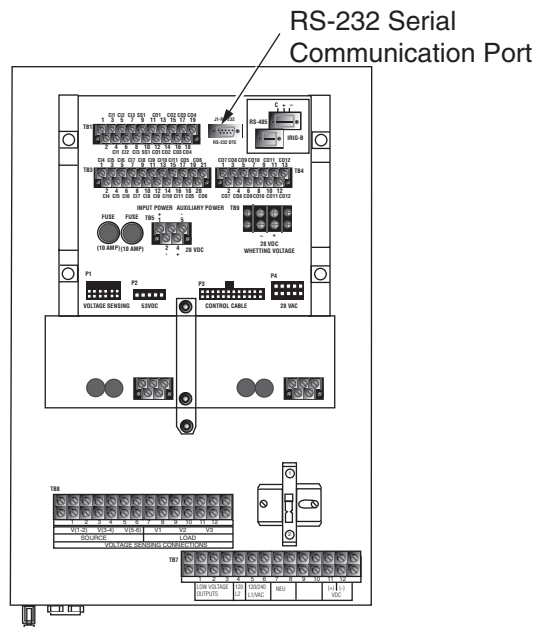

**Figure 23. Form 6-TS yard mount recloser control rear panel RS-232 communication port**

### J1-RS-232

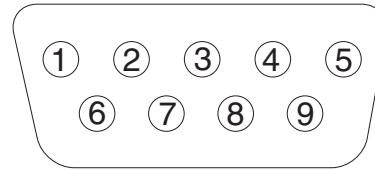

### RS-232 DTE

**Figure 24. Rear panel RS-232 communication port pin identification**

### Using removable inserts

#### NOTICE

**Control damage. De-energize both AC and DC power prior to removing or installing any internal connections or circuit boards in the control. Failure to comply can result in damage to the control.**

T241.1

#### NOTICE

**Equipment damage. Always wear a grounding wrist strap to control static electricity before handling circuit boards. Failure to use this strap may result in circuit board damage.**

T253.1

The front panel inserts can be changed, if desired.

1. De-energize both AC and DC power.
2. Use a flathead or 3/32" hex key screwdriver to unscrew the six front panel screws.
3. Pull the right side of the front panel out towards the left (Figure 25).

**Note:** Set the screws aside for later use.

**Note:** Various connecting wires will keep the panel attached to the control.

**Note:** It is not necessary to disconnect any wires.

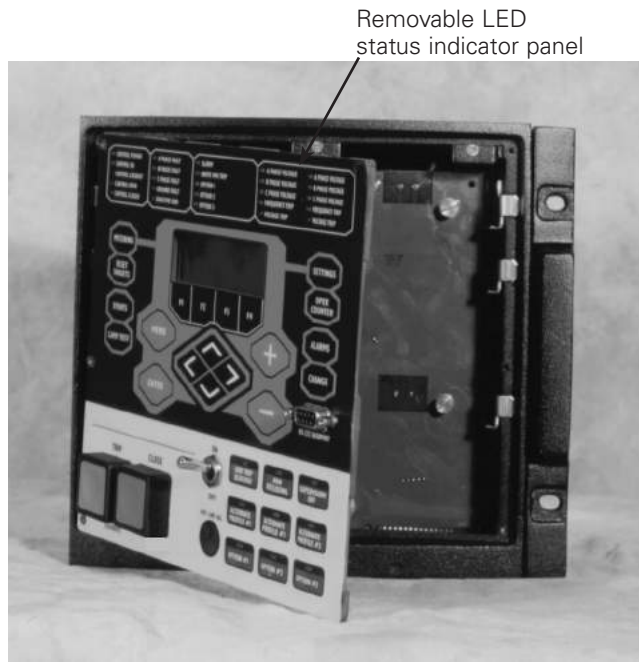

**Figure 25. Open front panel. Labels are easily removed from and inserted into the top of the programming panel LED status indicator section**

4. Use tweezers to gently pull out the removable insert.

**Note:** The insert will slide out of the right side of the operating panel (**Figure 26**).

**Note:** The insert will slide out of the top of the programming panel indicator section (**Figure 25**).

5. Change the existing label or slide in a new label with the name of the configured option.

An electronic label template is included on the ProView application software CD and can be accessed through the following default address:

C:\Program Files\Cooper\ProviewXX\Form 6\Form 6 Inserts.doc.

## IMPORTANT

Laminate the removable inserts prior to installing. This will seal the ink/toner and avoid damage to the front panel.

6. Gently push the removable insert from right to left into the right side of the operating panel (**Figure 25**) or down into the programming panel LED indicator section (**Figure 25**).

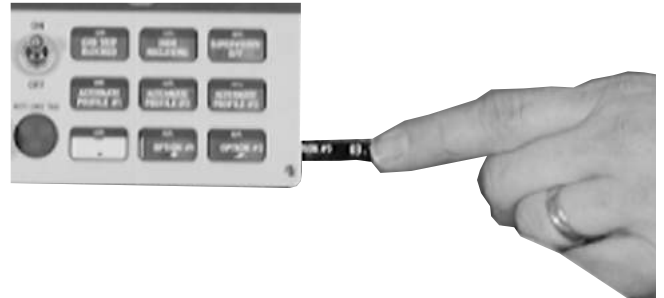

**Figure 26. Labels are easily removed from and inserted into the operating panel**

7. Place the front cover panel back onto the control. Use a flathead screwdriver to screw the screws back into the control and tighten all hardware completely.

# Form 6 triple-single microprocessor-based yard mount recloser control

## Accessories

These accessories are available. Contact your Eaton representative for additional information.

### 120 VAC GFI duplex outlet

The GFI Duplex Outlet (Catalog Number KME6-1820) is available for controls powered by 120 VAC VAC three-wire supply power. This convenience outlet is rated for 15 Amperes and is accessible through the front door in the control cabinet. The 120 VAC GFI Duplex Outlet is used for many applications such as power for the MET Tester, auxiliary measurement equipment, and supplemental lighting.

### Incoming power receptacles

The Incoming Power Receptacle allows the user to conveniently plug the power cable into the control, eliminating the need for hardwiring to the control. Various options are available based upon the input power voltage, and phase sensing requirements. **Table 6** includes the available input receptacles and cables for the Form 6-TS yard mount recloser control.

**Table 6. Input receptacles and cables**

Description	Catalog number
120 VAC or 240 VAC input receptacle, 2-pin	KME6-1838-H
120 VAC input receptacle, 3-pin	KME6-1838-J240
240 VAC input receptacle, 3-pin	KME6-1838-K
AC Input Cable, 120 or 240 VAC, 2-wire for 2-pin input for use with KME6-1838-H receptacle. Replace X with desired length. Select from 10 to 80 feet	KMA11ME1-X
AC Input Cable, 240 VAC, 3-wire for 3-pin input for use with KME6-1838-K receptacle. Replace X with desired length. Select from 10 to 80 feet	KME4-67-2-X
AC Input Cable, 120 VAC, 3-wire for 3-pin input for use with KME6-1838-J receptacle. Replace X with desired length. Select from 10 to 80 feet	KME4-67-3-X

### Heater receptacles

Two heater receptacles are available for the control for use with the NOVA STS recloser:

120 VAC heater receptacle with inlet hole and 2-pin outlet receptacle	KME6-1838-C
240 VAC heater receptacle, for 2-wire with inlet hole and 2-pin output receptacle	KME6-1838-F

### Discrete interface board (DIF) option accessory

A Discrete Interface Board Option accessory provides eight configurable input control contacts and eight configurable output status contacts (**Figure 27**). The ordering options include: Standard (3 inputs/5 outputs) or Additional (8 inputs/8 outputs).

### Cable locking sleeves

To prevent detachment of the control cable from the control cabinet by unauthorized personnel, cable-locking sleeves (Catalog Number KME6-1772-X) are available to enclose the cable plug.

**Note:** Replace X with the desired number of cable sleeves (1, 2, 3, 4, or 5).

The plug is passed through the sleeve and the sleeve is then fastened from inside the control cabinet. There is no access to the cable receptacle without opening the locked cabinet door and detaching the sleeve.

### BCT terminal block accessory

The BCT Terminal Block (Catalog Number KME6-1773-A) attaches to the back of the control and provides a connection point for external 600:5 or 1200:5 multi-ratio bushing current transformers. A BCT Terminal Blocks is available for the load side and includes wire for all ratios of the BCT.

**Eight Control Inputs and Eight Status Outputs (Accessory)**

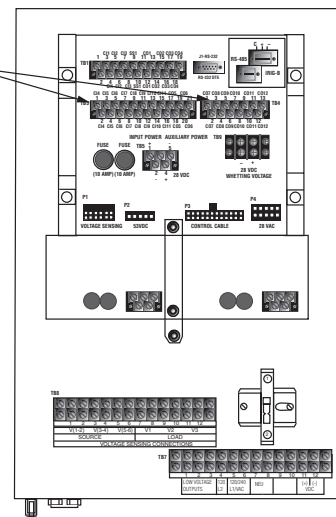

**Figure 27. Form 6-TS yard mount recloser control discrete interface board accessory**

## Communication board accessories

The Form 6-TS yard mount control is equipped with a Communication Board Accessory (expansion bay) offering versatile support for modern communication media.

Six distinct communication options (**Figure 28**) are available, providing two-way, real time digital communications with a remote terminal unit (RTU), wireless, telephone modem, Ethernet network, or other communication devices. The following options are available:

- No auxiliary communication card installed (standard)
- RS485 (isolated) Serial communication card
- Fiber-optic-based Serial Communication Card (ST)
- 10/100 Base-T dual Ethernet communication card (2\*RJ-45)
- 100 Base-FX dual Ethernet communication card (2\*MT-RJ)
- 10/100 Base-T, 100 Base-FX Ethernet communication card (RJ-45 + MT-RJ)

The expansion bay based Communication Board Accessory concept offers high versatility with respect to communication medium and protocol support. Additional accessories are being continuously developed. Contact your Eaton representative for the latest information regarding particular media and communication protocol support.

## RS485 serial communication card

The RS485 serial communication card accessory provides means for establishing asynchronous link-based digital communications with the Form 6-TS yard mount control. The Galvanic isolated (1000 VDC) RS485 port uses a single shielded twisted pair connection and can support 32 devices in multi-drop configuration. Communication speed is controlled through software and can be set at: 1200, 2400, 4800, 9600, 19.2 k, 38.4 k, 57.6 k, and 115k BPS.

Digital communications must be programmed through the Communications Workbench to ensure proper operation of the RS485 communication card accessory. Refer to *Service Information S280-70-9 (ProView 4.X.X) or S280-70-23 (ProView 5.X.X) Form 6-TS Control Programming Guide* for additional information.

## Fiber-optic based serial communication card

The Fiber-Optic based Serial Communication Card offers means of establishing asynchronous (RS-232 like) digital communications through multi-mode fiber media. The use of the fiber-optic based serial communication card accessory can enhance communication reliability, and provides excellent electrical isolation thus protecting transmitted data from extraneous electrical interference.

An optional fiber-optic-to-RS-232 converter with DB-9 connector (Catalog Number KME6-1875-1) is available for interfacing between an optical signal and a hard-wired RS-232 signal, when required. This converter is compatible with loop (ring) and point-to-point (star) configurations.

A pair of industry standard ST type fiber-optic connectors are mounted on the back of the board enabling customer connection to a digital communication system using fiber-optic cables (customer-supplied).

The fiber-optic link has separate receive (RX) and transmit (TX) ports operating at 820nm. Typical transmission distance is 2000 m with 62.5/125  $\mu$ m multi-mode fiber. Consult your Eaton representative for availability of long haul solutions. Link communication speed is controlled through software and can be set at: 1200, 2400, 4800, 9600, 19.2 k, and 38.4 k. Modbus can also be set at 57.6 k.

The fiber-optic accessory must be programmed through the Communications Workbench for the appropriate protocol. Refer to *Service Information S280-70-9 (ProView 4.X.X) or S280-70-23 (ProView 5.X.X) Form 6-TS Control Programming Guide* for additional information.

The fiber-optic based serial accessory includes TX and RX indicating LEDs for verifying communications along with an echo / non-echo switch for supporting ring / star fiber topologies.

When operated in a ring configuration, the toggle switch must be set in the ECHO position. In this mode, the fiber-optic card will repeat (pass through) all messages received on the RX fiber, and will respond to the Master station by first echoing the incoming command and then sending the response. This arrangement is best suited for creation of low cost multi device fiber loops. For reliable communications, the fiber loop system requires that all devices in the loop remain powered at all times, thus enabling unobstructed flow of information throughout the loop.

A more resilient system can be designed by using the fiber-optic ports in a point-to-point or multiple point-to-point (star) configuration. For this mode, the toggle switch must be set in the NON-ECHO mode. The Form 6-TS yard mount control will respond to the Master station by sending a response only (total separation of Receive and Transmit fibers). Additional hardware (fiber-optic star coupler) is required to support the multiple point-to-point device configurations.

## Ethernet communication cards

The Ethernet communication card accessory brings the Ethernet network connectivity to the Form 6-TS yard mount recloser control platform. It is highly flexible, offering simultaneous support for multiple sessions, device management (ProView over TCP/IP) and SCADA communications (DNP3 over TCP/IP).

By natively supporting a set of widely accepted industry standards (TCP/IP, UDP/IP, OSI) the Ethernet communication accessory ensures seamless interoperability with other network devices.

## Form 6 triple-single microprocessor-based yard mount recloser control

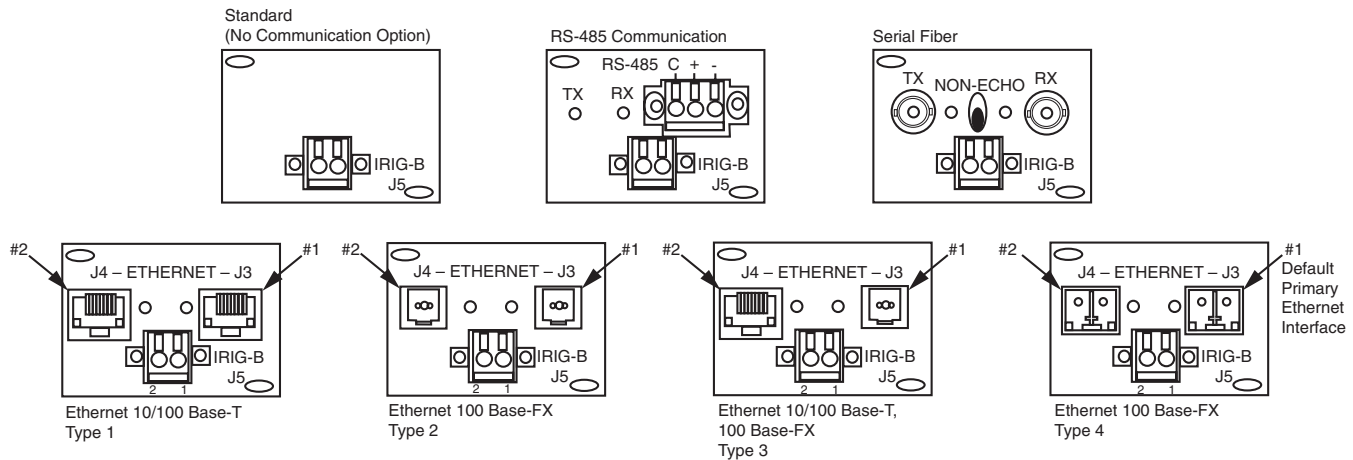

**Figure 28. Back panel ethernet and communication options**

The Ethernet communication card accessory is offered in 3 physical layer configurations (twisted pair and optical-fiber options) as shown in **Table 7**.

**Table 7. Ethernet communication card configurations**

Type	Card configurations	Output connectors	Communication speed
1	10/100 Base-T	2 * RJ-45	10 / 100 MBps (auto switching)
2	100 Base-FX (multi-mode fiber)	2 * MT-RJ	100 MBps (full duplex)
3	10/100 Base-T, 100 Base-FX	RJ-45 + MT-RJ	10/100 MBps and 100 MBps
4	100 Base-FX, (single-mode fiber)	2 * LC	100 MBps (full duplex)

Maximum link length is determined by the use of the particular physical layer implementation, and can be further constrained by the actual network configuration. In case of the 100Base-FX MT-RJ connector based implementation, maximum link length in excess of 2000 m can be achieved with 62.5/125  $\mu$ m multi mode fiber. The fiber-optic link uses 1300 nm wavelength, and can easily be interfaced to other 100Base-FX solutions (ST connector patch cord solution).

The Ethernet communication accessory card (**Figure 28**) is equipped with two physical ports configured to act as primary and standby LAN connections. Availability of the backup communication port enables creation of highly redundant Ethernet networks thus increasing the overall system reliability.

**Note:** Under normal network conditions, all communications will be channeled through the primary port (#1, **Figure 28**), with the standby port either logically disabled, or configured for fast automatic throw-over in case of the primary Ethernet link failure. Refer to *Service Information S280-70-9 (ProView 4.X.X)* or *S280-70-23 (ProView 5.X.X) Form 6-TS Control Programming Guide* for additional Ethernet accessory configuration information.

## Testing

### CAUTION

**Equipment misoperation. Do not connect this control to an energized recloser until all control settings have been properly programmed and verified. Refer to the programming information for this control. Failure to comply can result in control and recloser misoperation, equipment damage, and personal injury.**

G110.3

### IMPORTANT

The Form 6 recloser control can be taken out of service for testing and placed back into service without de-energizing its recloser and interrupting the system. However, during the time the control is out of service, the recloser is inoperative.

### Testing an installed control

The following tests to determine initial operation of the Form 6-TS yard mount recloser control can be performed while connected to an operating recloser.

**Note:** These are the only tests performed on an installed, operating control.

1. Verify operating status of all indicator lights by pressing and holding the LAMP TEST key for two seconds on the programming panel (**Figure 29**).
2. Check the operational values for currents, voltages, and other metering information.

**Note:** Scroll through the LCD display messages by pressing the  $\uparrow$  and  $\downarrow$  cursor movement arrows underneath the LCD display on the programming panel (**Figure 29**).

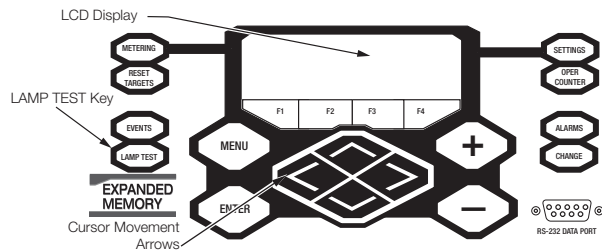

**Figure 29. Lamp test button, LCD display, and cursor movement arrows**

3. Check that the LED for Control OK is illuminated on the control operator panel (**Figure 30**). This indicates the presence of DC power.

**Note:** The control includes a Power Save feature that will turn off the backlit LCD display and all LEDs if no front panel keypad is pressed within ten minutes. Pressing the LAMP TEST key will reactivate the display and active LEDs.

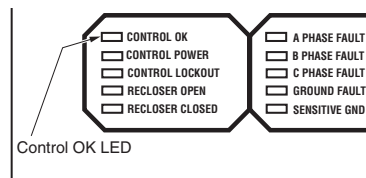

**Figure 30. Control OK LED**

All other tests described in this **Testing** section require the Form 6-TS yard mount recloser control to be removed from service, connected to a bypassed recloser, or tested at a location where the proper testing equipment is available. Refer to **Remove the control from service** for the proper procedure to remove the control from service.

### Remove the control from service

#### IMPORTANT

Disconnect switches for AC sensing and power connections are necessary to isolate the Form 6-TS control for testing and servicing.

1. Enable GND TRIP BLOCKED to allow for ground trip to be disabled when re-energized.
  - A. Press the CHANGE button on the Operator Panel to enter the CHANGE mode.
  - B. Depress the GND TRIP BLOCKED button within ten seconds after entering the CHANGE mode.

**Note:** If the GND TRIP BLOCK button is not depressed within ten seconds, the function is not activated.

2. Remove DC power from the control using a separate disconnect switch.

3. Remove control AC sensing voltage from the control using a separate disconnect switch.

#### CAUTION

**Hazardous voltage. Open CT secondaries can generate high voltages. Contact with CT pins of the disconnected cable can cause electric shock and may result in personal injury. Open recloser contacts and open disconnect switches before disconnecting control cable.**

T204.3

4. Disconnect control cable from control.

**Note:** Do not disconnect any of the recloser cables from the recloser(s) or junction box unless all of the above steps have been completed. Refer to the appropriate recloser instructions:

- *Service Information MN280045EN NOVA-TS Recloser Installation and Operation Instructions*
- *Service Information MN280046EN NOVA STS Recloser Installation and Operation Instructions*

5. Remove any control input and status output wiring from TB1, TB3, and TB4 (**Figure 7**).
6. Disconnect any serial communications ports and IRIG-B timing connections (**Figure 7**).
7. Disconnect the ground from the control.
8. Carefully transport the control to a suitable service facility.

### Electrical testing of triple-single reclosers: NOVA-TS and NOVA STS

#### WARNING

**Hazardous voltage. Solidly ground all equipment. Failure to comply can result in death, severe personal injury, and equipment damage.**

T223.2

Each unit in the Type NOVA-TS Triple-Single recloser utilizes an interface circuit located in its mechanism housing. The electronic interface circuit controls the opening and closing signals to the magnetic actuator.

**Figure 31** shows a test circuit for NOVA-TS reclosers with the Form 6-TS control.

**Note:** The same test circuit set-up can be applied to each phase when testing the NOVA STS recloser, except connection is direct from the control to the recloser. No junction box is required.

#### IMPORTANT

To ensure proper operation, always verify that the three cables between the junction box and the reclosers are connected when the control is in single-phase trip, three-phase lockout mode or three-phase trip, three-phase lockout (ganged) mode.

## Form 6 triple-single microprocessor-based yard mount recloser control

Use this circuit to simulate load current and for testing minimum trip operation and sequencing the mechanism with the Form 6-TS control for each phase.

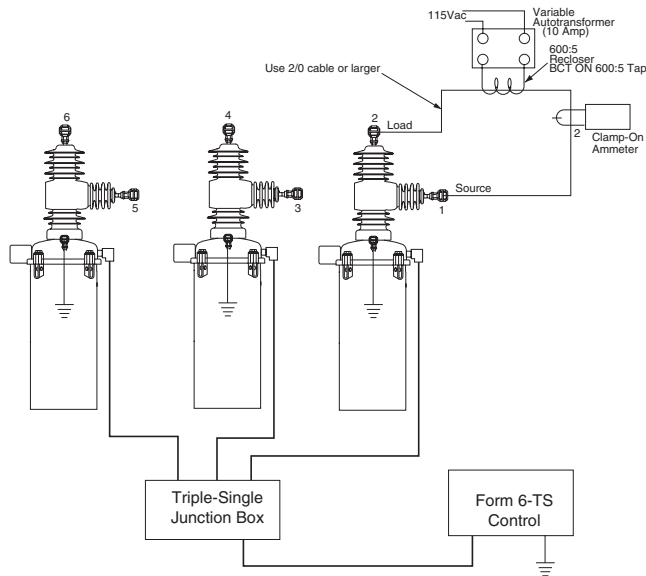

**Figure 31. Suggested test circuit for NOVA-TS triple-single reclosers with Form 6-TS control**

### Return the control to service

#### **WARNING**

This equipment is not intended to protect human life. Follow all locally approved procedures and safety practices when installing or operating this equipment. Failure to comply can result in death, severe personal injury, and equipment damage.

G102.1

After the required work or testing is completed, follow this procedure to return the control to service:

#### **CAUTION**

Equipment misoperation. Do not connect this control to an energized recloser until all control settings have been properly programmed and verified. Refer to the programming information for this control. Failure to comply can result in control and recloser misoperation, equipment damage, and personal injury.

G110.3

1. Verify that all control settings are correct prior to installation.

#### **WARNING**

**Hazardous voltage. Recloser and control must be solidly grounded. Follow all locally approved procedures and safety practices when grounding this equipment. Improper grounding can result in contact with high voltage, which will cause death or severe personal injury.**

G115.1

2. Connect the ground to the control.

**Note:** Refer to **Grounding the control** section.

#### **CAUTION**

**Hazardous voltage. Open CT secondaries can generate high voltages. Contact with CT pins of the disconnected cable can cause electric shock and may result in personal injury. Open recloser contacts and open disconnect switches before disconnecting control cable.**

T204.3

3. Connect control cable to the control.
4. Connect control AC sensing voltage to the control via disconnect switches.

**Note:** Refer to **Customer connections for DC power and AC voltage sensing** section.

5. Connect DC power to the control via disconnect switches.

**Note:** Refer to **Customer connections for DC power and AC voltage sensing** section.

6. The triple-single recloser(s) and Form 6-TS control are ready for service. Once installed, remove bypass switches on the recloser.

7. Disable GND TRIP BLOCKED.

A. Press the CHANGE button on the Operator Panel to enter the CHANGE mode.

B. Depress the GND TRIP BLOCKED button within ten seconds after entering the CHANGE mode.

**Note:** If the GND TRIP BLOCK button is not depressed within ten seconds, the function is not activated.



## Additional information

### CAUTION

**This equipment requires routine inspection and maintenance to ensure proper operation. If it is not maintained, it can fail to operate properly. Improper operation can cause equipment damage and possible personal injury.**

G105.1

### Replacement kits

Replacement kits for the Form 6-TS yard mount recloser control are available through the factory Service Department. To order these kits, refer to the Replacement Parts price list for catalog numbers and pricing. Contact your Eaton representative for additional information and order procedures.

### Factory-authorized service centers

Factory-authorized service centers are located throughout the continental United States to provide maintenance, repair and testing services for Eaton's Cooper Power series controls and reclosers. For further information, contact your Eaton representative.

### Factory testing and troubleshooting classes

The factory service department offers a basic testing and troubleshooting course for the Form 6 microprocessor-based recloser control. This course, taught by experienced service technicians, is held at the factory's in-house training facility. For additional information, contact your Eaton representative.

This page intentionally left blank.

This page intentionally left blank.



**Eaton**  
1000 Eaton Boulevard  
Cleveland, OH 44122  
United States  
Eaton.com

**Eaton's Power Systems Division**  
2300 Badger Drive  
Waukesha, WI 53188  
United States  
Eaton.com/cooperpowerseries

© 2018 Eaton  
All Rights Reserved  
Printed in USA  
Publication No. MN280085EN  
KA 2048-652 Rev: 03  
June 2018

Eaton is a registered trademark.

All trademarks are property  
of their respective owners.

For Eaton's Cooper Power series product  
information  
call 1-877-277-4636 or visit:  
[www.eaton.com/cooperpowerseries](http://www.eaton.com/cooperpowerseries).