

Form 6 recloser control KME6-1875-1, KME6-1875-2, and  
KME6-1875-3 fiber optic converter kits installation instructions

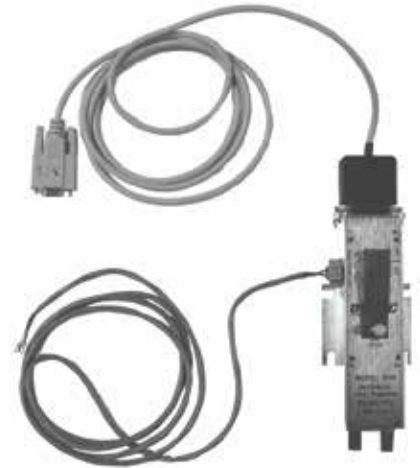
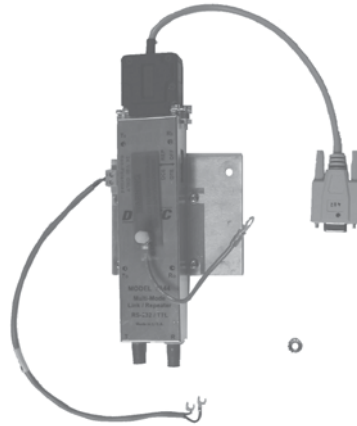
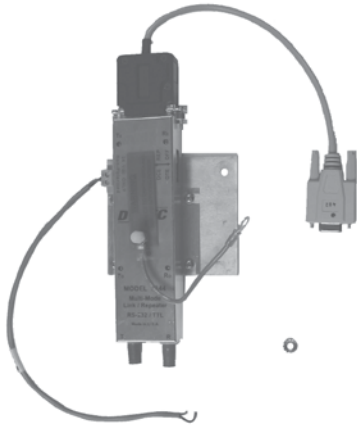

## **DISCLAIMER OF WARRANTIES AND LIMITATION OF LIABILITY**

The information, recommendations, descriptions and safety notations in this document are based on Eaton Corporation's ("Eaton") experience and judgment and may not cover all contingencies. If further information is required, an Eaton sales office should be consulted. Sale of the product shown in this literature is subject to the terms and conditions outlined in appropriate Eaton selling policies or other contractual agreement between Eaton and the purchaser.

THERE ARE NO UNDERSTANDINGS, AGREEMENTS, WARRANTIES, EXPRESSED OR IMPLIED, INCLUDING WARRANTIES OF FITNESS FOR A PARTICULAR PURPOSE OR MERCHANTABILITY, OTHER THAN THOSE SPECIFICALLY SET OUT IN ANY EXISTING CONTRACT BETWEEN THE PARTIES. ANY SUCH CONTRACT STATES THE ENTIRE OBLIGATION OF EATON. THE CONTENTS OF THIS DOCUMENT SHALL NOT BECOME PART OF OR MODIFY ANY CONTRACT BETWEEN THE PARTIES.

In no event will Eaton be responsible to the purchaser or user in contract, in tort (including negligence), strict liability or otherwise for any special, indirect, incidental or consequential damage or loss whatsoever, including but not limited to damage or loss of use of equipment, plant or power system, cost of capital, loss of power, additional expenses in the use of existing power facilities, or claims against the purchaser or user by its customers resulting from the use of the information, recommendations and descriptions contained herein. The information contained in this manual is subject to change without notice.

**Contents**

**DISCLAIMER OF WARRANTIES AND LIMITATION OF LIABILITY** ..... **I**

**SAFETY FOR LIFE** ..... **III**

**SAFETY INFORMATION** ..... **III**  
    Safety instructions ..... iii

**PRODUCT INFORMATION** ..... **1**  
    Introduction ..... 1  
    ANSI standards ..... 1  
    Quality standards ..... 1  
    Acceptance and initial inspection ..... 1  
    Handling and storage ..... 1  
    Description ..... 1

**INSTALLATION** ..... **1**  
    KME6-1875-1 fiber optic converter kit for form 6 pole mount control ..... 1  
    KME6-1875-2 fiber optic converter kit for form 6 yard mount control ..... 4  
    KME6-1875-3 fiber optic converter kit for form 6 rack mount control ..... 6



## Safety for life



Eaton meets or exceeds all applicable industry standards relating to product safety in its Cooper Power™ series products. We actively promote safe practices in the use and maintenance of our products through our service literature, instructional training programs, and the continuous efforts of all Eaton employees involved in product design, manufacture, marketing, and service.

We strongly urge that you always follow all locally approved safety procedures and safety instructions when working around high voltage lines and equipment, and support our “Safety For Life” mission.

## Safety information

The instructions in this manual are not intended as a substitute for proper training or adequate experience in the safe operation of the equipment described. Only competent technicians who are familiar with this equipment should install, operate, and service it.

A competent technician has these qualifications:

- Is thoroughly familiar with these instructions.
- Is trained in industry-accepted high and low-voltage safe operating practices and procedures.
- Is trained and authorized to energize, de-energize, clear, and ground power distribution equipment.
- Is trained in the care and use of protective equipment such as arc flash clothing, safety glasses, face shield, hard hat, rubber gloves, clampstick, hotstick, etc.

Following is important safety information. For safe installation and operation of this equipment, be sure to read and understand all cautions and warnings.

### Hazard Statement Definitions

This manual may contain four types of hazard statements:

#### DANGER

Indicates an imminently hazardous situation which, if not avoided, will result in death or serious injury.

#### WARNING

Indicates a potentially hazardous situation which, if not avoided, could result in death or serious injury.

#### CAUTION

Indicates a potentially hazardous situation which, if not avoided, may result in minor or moderate injury.

#### CAUTION

Indicates a potentially hazardous situation which, if not avoided, may result in equipment damage only.

### Safety instructions

Following are general caution and warning statements that apply to this equipment. Additional statements, related to specific tasks and procedures, are located throughout the manual.

#### DANGER

**Hazardous voltage. Contact with hazardous voltage will cause death or severe personal injury. Follow all locally approved safety procedures when working around high- and low-voltage lines and equipment.**

G103.3

#### WARNING

**Before installing, operating, maintaining, or testing this equipment, carefully read and understand the contents of this manual. Improper operation, handling or maintenance can result in death, severe personal injury, and equipment damage.**

G101.0

#### WARNING

**This equipment is not intended to protect human life. Follow all locally approved procedures and safety practices when installing or operating this equipment. Failure to comply can result in death, severe personal injury and equipment damage.**

G102.1

#### WARNING

**Power distribution and transmission equipment must be properly selected for the intended application. It must be installed and serviced by competent personnel who have been trained and understand proper safety procedures. These instructions are written for such personnel and are not a substitute for adequate training and experience in safety procedures. Failure to properly select, install or maintain power distribution and transmission equipment can result in death, severe personal injury, and equipment damage.**

G122.3

# Form 6 recloser control KME6-1875-1, KME6-1875-2, and KME6-1875-3 fiber optic converter kits installation instructions

## Product information

### Introduction

Service Information MN280079EN provides installation instructions for Eaton Cooper Power series Form 6 recloser control KME6-1875-1, KME6-1875-2, and KME6-1875-3 fiber optic converter kits.

### Read this manual first

Read and understand the contents of this manual and follow all locally approved procedures and safety practices before installing or operating this equipment.

### Additional information

These instructions cannot cover all details or variations in the equipment, procedures, or process described, nor provide directions for meeting every possible contingency during installation, operation, or maintenance. For additional information, contact your Eaton representative.

### ANSI standards

Eaton Cooper Power series reclosers are designed and tested in accordance with the following ANSI standards: C37.60 and C37.85 and ANSI Guide C37.61.

### Quality standards

ISO 9001-Certified Quality Management System.

### Acceptance and initial inspection

Each Form 6 recloser control fiber optic converter kit is in good condition at the factory and when accepted by the carrier for shipment.

Upon receipt, inspect the carton for signs of damage. Unpack the kit(s) and inspect it thoroughly for damage incurred during shipment. If damage is discovered, file a claim with the carrier immediately.

### Handling and storage

Be careful during handling and storage of the kit to minimize the possibility of damage. If the kit is to be stored for any length of time prior to installation, provide a clean, dry storage area.

## Description

The fiber optic converter accessory provides a permanent link for two-way, real-time, serial communications with a remote terminal unit (RTU), telephone modem, or personal computer.

The instructions for these three Form 6 recloser control fiber optic accessory kits are included in this manual:

- KME6-1875-1 Form 6 Pole Mount Control Kit
- KME6-1875-2 Form 6 Yard Mount Control Kit
- KME6-1875-3 Form 6 Rack Mount Control Kit

---

## IMPORTANT

---

**This kit can not be combined, installed, or used with the KME6-1801-1 auxiliary switch accessory kit available for the Form 6 pole and yard mount recloser controls.**

For additional information on installing the control, removing the control from service, and control testing procedures, refer to the appropriate service manual for additional information:

- *Service Information MN280075EN Form 6 Rack Mount Recloser Control Installation and Operation Instructions*
- *Service Information MN280076EN Form 6 Yard Mount Recloser Control Installation and Operation Instructions*
- *Service Information MN280077EN Form 6 Pole Mount Recloser Control Installation and Operation Instructions*
- *Service Information S280-70-4 Form 6 Recloser Control Programming Guide*

## Installation

### KME6-1875-1 fiber optic converter kit for form 6 pole mount control

---

## IMPORTANT

---

**This kit can not be combined, installed, or used with the KME6-1801-1 auxiliary switch accessory kit.**

# Form 6 recloser control KME6-1875-1, KME6-1875-2, and KME6-1875-3 fiber optic converter kits installation instructions

## Installation instructions

Refer to Table 1 and Figures 2 and 3 and follow this procedure to install the KME6-1875-1 fiber optic converter kit on the Form 6 rack mount recloser control.

### **CAUTION**

**Recloser misoperation. The control must be removed from service prior to performing any maintenance, testing, or programming changes. Failure to comply can result in misoperation (unintentional operation) of the recloser.**

T216.2

1. Remove the Form 6 pole mount recloser control from service.

Refer to *Service Information MN280077EN Form 6 Microprocessor-Based Pole Mount Recloser Control Installation and Operation Instructions* for the procedure **Remove the Control from Service.**

### **IMPORTANT**

**Make sure the power is turned off and the battery is disconnected.**

2. Carefully transport the recloser control to a suitable service facility.

**Note:** The entire kit installation process should be conducted in a clean environment, such as a repair shop.

### **CAUTION**

**Control damage. De-energize both ac and dc power prior to removing or installing any internal connections or circuit boards in the control. Failure to comply can result in damage to the control.**

T241.1

3. Verify the battery is disconnected from the control.
4. Verify the fiber optic converter DTE/DCE switch is set to the DCE position and the mode switch is in the OFF position.

**Note:** The mode switch enables the repeater function in the REP position and disables it in the OFF position.

### **CAUTION**

**Equipment damage. Always wear a grounding wrist strap to control static electricity before handling circuit boards. Failure to use this strap may result in circuit board damage.**

T253.1

5. Mount the fiber optic converter on the mounting stud inside the back right side of the control cabinet.

**Note:** The mounting hole is provided on the attached mounting plate.

6. Place the #10 terminal of the wire assembly lead on the mounting stud.
  7. Secure the fiber optic converter and #10 terminal of the wire assembly lead to the mounting stud with the hex nut (Item 2). Tighten completely.
  8. Connect the 9-pin cable to the RS-232 port and tighten.
  9. Remove the green 2-pin connector from the 24 Volt P3 circuit board header on the power supply board.  
  
P3 is located behind the battery load tester resistor and P2 heater wiring assembly plug as shown in Figure 3.
- Note:** If the control does not already have a green 2-pin connector, contact your Eaton representative to order one.
10. Connect the loose end of the fiber optic power cable to the green 2-pin connector.
    - A. Insert the wires into the connector as shown in the inset in Figure 3.
    - B. Secure the wires by tightening the screws into the side of the connector with a screwdriver.
  11. Re-attach the green 2-pin connector to the 2-position 24 Volt P3 circuit board header on the power supply board.

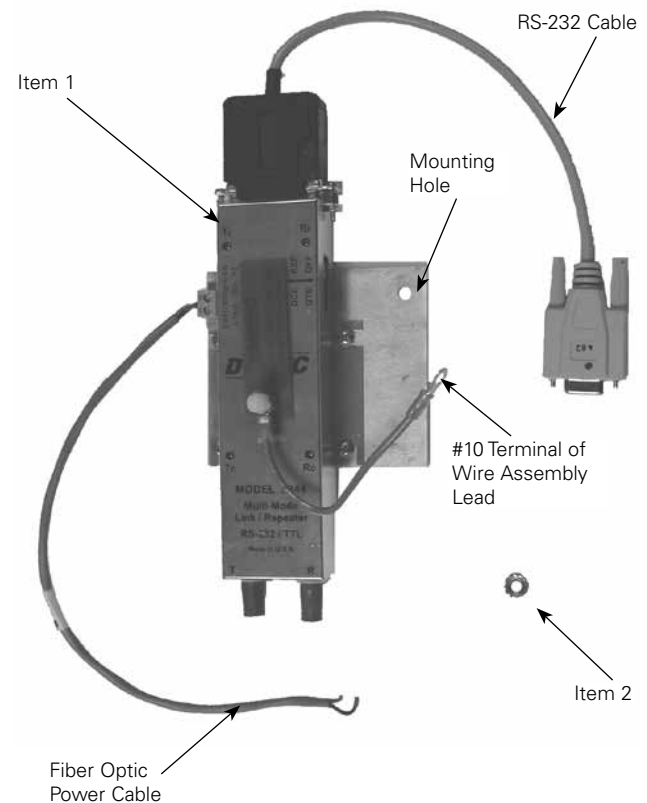

**Figure 1. KME6-1875-1 fiber optic converter assembly parts identification**

Form 6 recloser control KME6-1875-1, KME6-1875-2, and KME6-1875-3  
 fiber optic converter kits installation instructions

**CAUTION**

Equipment misoperation. Do not connect this control to an energized recloser until all control settings have been properly programmed and verified. Refer to the programming information for this control. Failure to comply can result in control and recloser misoperation, equipment damage, and personal injury. G110.3

12. Verify the RS-232 and RS-485 Communication Ports are set for the intended protocol:
  - Modbus
  - DNP3 Protocol, Level 2
  - 2179

The RS-232 and RS-485 data ports can be specified with DNP3, 2179, or Modbus protocol. The protocol is user-configured to either the RS-232 or RS-485 serial ports via the ProView™ interface software.

Refer to the **Communications Workbench™** section of *Service Information S280-70-4 Form 6 Microprocessor-Based Recloser Control Programming Guide* for additional information.

**CAUTION**

Equipment misoperation. Do not energize this equipment until all control settings have been properly programmed and verified. Refer to the electronic control installation manual for programming procedures. Failure to comply can result in misoperation (unintended operation), equipment damage, and personal injury. G119.2

13. Return the Form 6 pole mount recloser control to service.

Refer to *Service Information MN280077EN Form 6 Microprocessor-Based Pole Mount Recloser Control Installation and Operation Instructions* for the procedure **Return the Control to Service**.

**Table 1. KME6-1875-1 form 6 pole mount recloser control fiber optic converter kit parts**

Item	Description	Quantity
1	Fiber optic converter assembly	1
2	Nut, hex machine screw, #10-32, KEPS, stainless steel	1

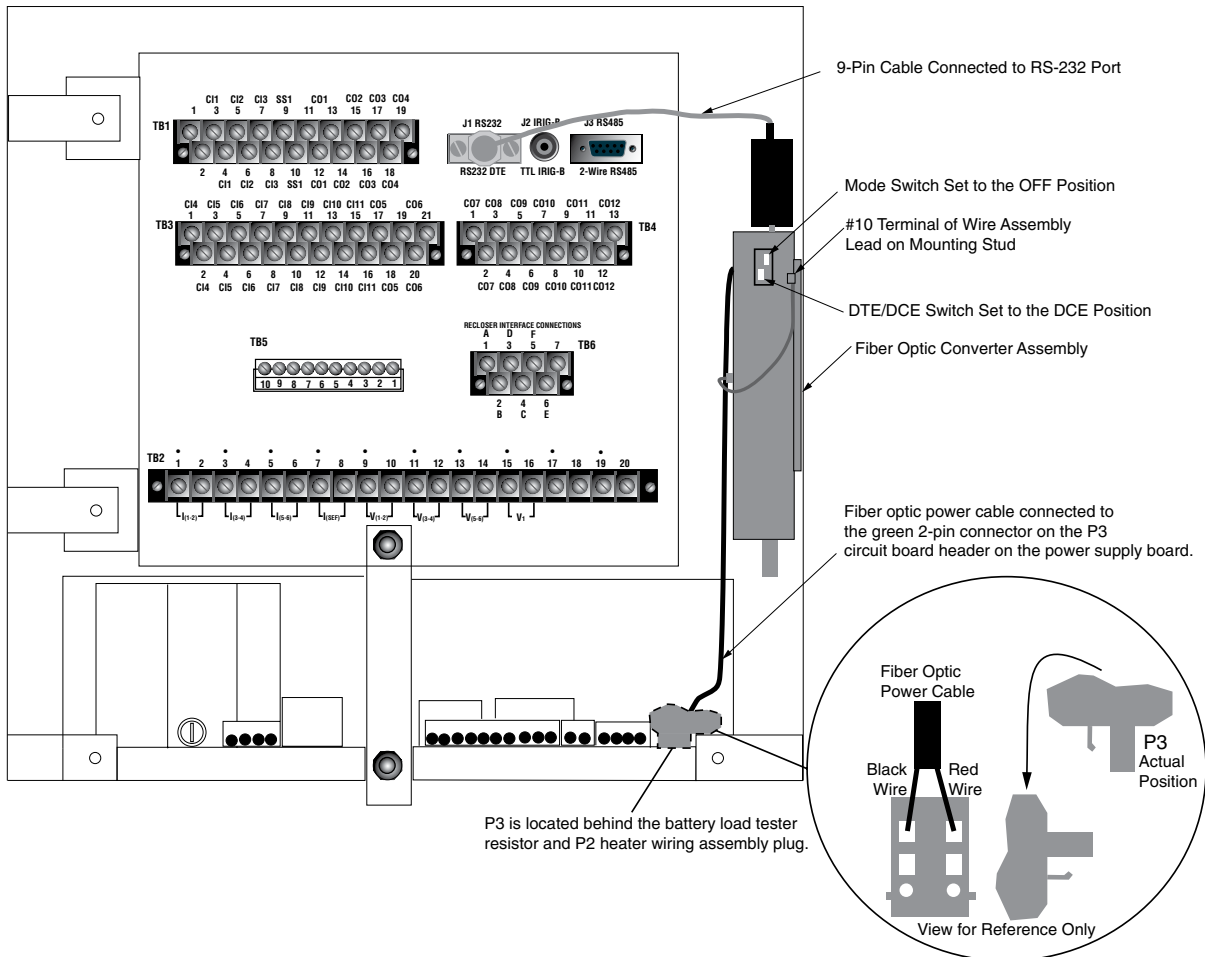

**Figure 2. KME6-1875-1 fiber optic converter installed in the Form 6 pole mount recloser control cabinet**

**KME6-1875-2 fiber optic converter kit for form 6 yard mount control**

**IMPORTANT**

**This kit can not be combined, installed, or used with the KME6-1801-1 auxiliary switch accessory kit.**

**Installation Instructions**

Refer to Table 2 and Figures 4 and 5 and follow this procedure to install the KME6-1875-2 fiber optic converter kit on the Form 6 yard mount recloser control.

**CAUTION**

**Recloser misoperation. The control must be removed from service prior to performing any maintenance, testing, or programming changes. Failure to comply can result in misoperation (unintentional operation) of the recloser.**

T216.2

1. Remove the Form 6 yard mount recloser control from service.

Refer to *Service Information MN280076EN Form 6 Microprocessor-Based Yard Mount Recloser Control Installation and Operation Instructions* for the procedure **Remove the Control from Service.**

2. Carefully transport the recloser control to a suitable service facility.

**Note:** The entire kit installation process should be conducted in a clean environment, such as a repair shop.

3. Verify the fiber optic converter DTE/DCE switch is set to the DCE position and the mode switch is in the OFF position.

**Note:** The mode switch enables the repeater function in the REP position and disables it in the OFF position.

**CAUTION**

**Control damage. De-energize both ac and dc power prior to removing or installing any internal connections or circuit boards in the control. Failure to comply can result in damage to the control.**

T241.1

**CAUTION**

**Equipment damage. Always wear a grounding wrist strap to control static electricity before handling circuit boards. Failure to use this strap may result in circuit board damage.**

T253.1

4. Mount the fiber optic converter on the mounting stud inside the back right side of the control cabinet.

**Note:** The mounting hole is provided on the attached mounting plate.

5. Place the #10 terminal of the wire assembly lead on the mounting stud.

**Table 2. KME6-1875-2 form 6 yard mount recloser control fiber optic converter kit parts**

Item	Description	Quantity
1	Fiber optic converter assembly	1
2	#10-32 hex nut w/captive hardware	1

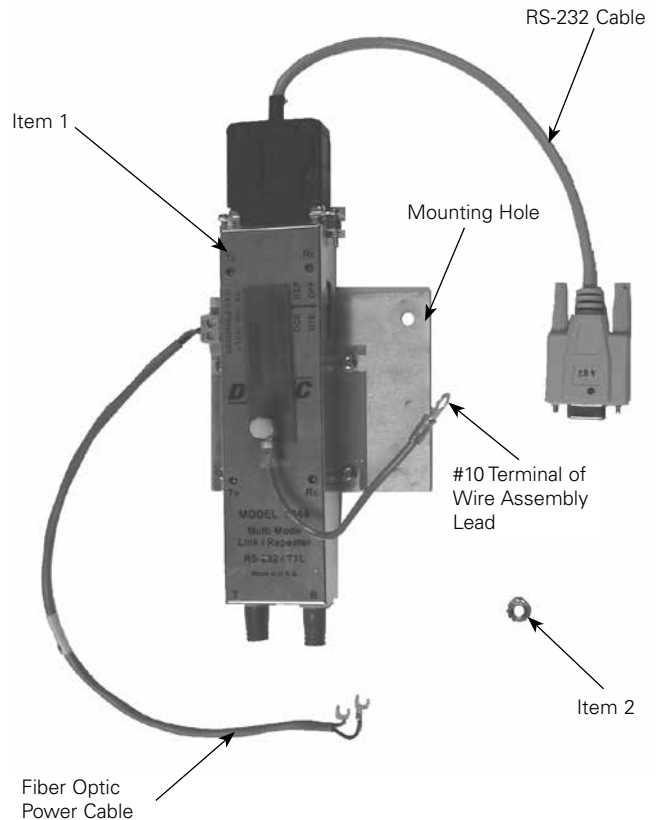

**Figure 3. KME6-1875-2 fiber optic converter assembly parts identification**

6. Secure the fiber optic converter and #10 terminal of the wire assembly lead to the mounting stud with the hex nut (Item 2). Tighten completely.
7. Connect the 9-pin cable to the RS-232 port and tighten.
8. Connect the fiber optic power cable to Terminal Block TB5 as follows:
  - A. Connect the black wire to TB5-5.
  - B. Connect the red wire to TB5-4.



Form 6 recloser control KME6-1875-1, KME6-1875-2, and KME6-1875-3  
 fiber optic converter kits installation instructions

**CAUTION**

**Equipment misoperation. Do not connect this control to an energized recloser until all control settings have been properly programmed and verified. Refer to the programming information for this control. Failure to comply can result in control and recloser misoperation, equipment damage, and personal injury.**

G110.3

9. Verify the RS-232 and RS-485 Communication Ports are set for the intended protocol:
  - Modbus
  - DNP3 Protocol, Level 2
  - 2179

The RS-232 and RS-485 data ports can be specified with DNP3, 2179, or Modbus protocol. The protocol is user-configured to either the RS-232 or RS-485 serial ports via the ProView™ interface software.

Refer to the **Communications Workbench™** section of *Service Information S280-70-4 Form 6 Microprocessor-Based Recloser Control Programming Guide* for additional information.

**CAUTION**

**Equipment misoperation. Do not energize this equipment until all control settings have been properly programmed and verified. Refer to the electronic control installation manual for programming procedures. Failure to comply can result in misoperation (unintended operation), equipment damage, and personal injury.**

G119.2

10. Return the Form 6 yard mount recloser control to service.

Refer to *Service Information MN280076EN Form 6 Microprocessor-Based Yard Mount Recloser Control Installation and Operation Instructions* for the procedure **Return the Control to Service**.

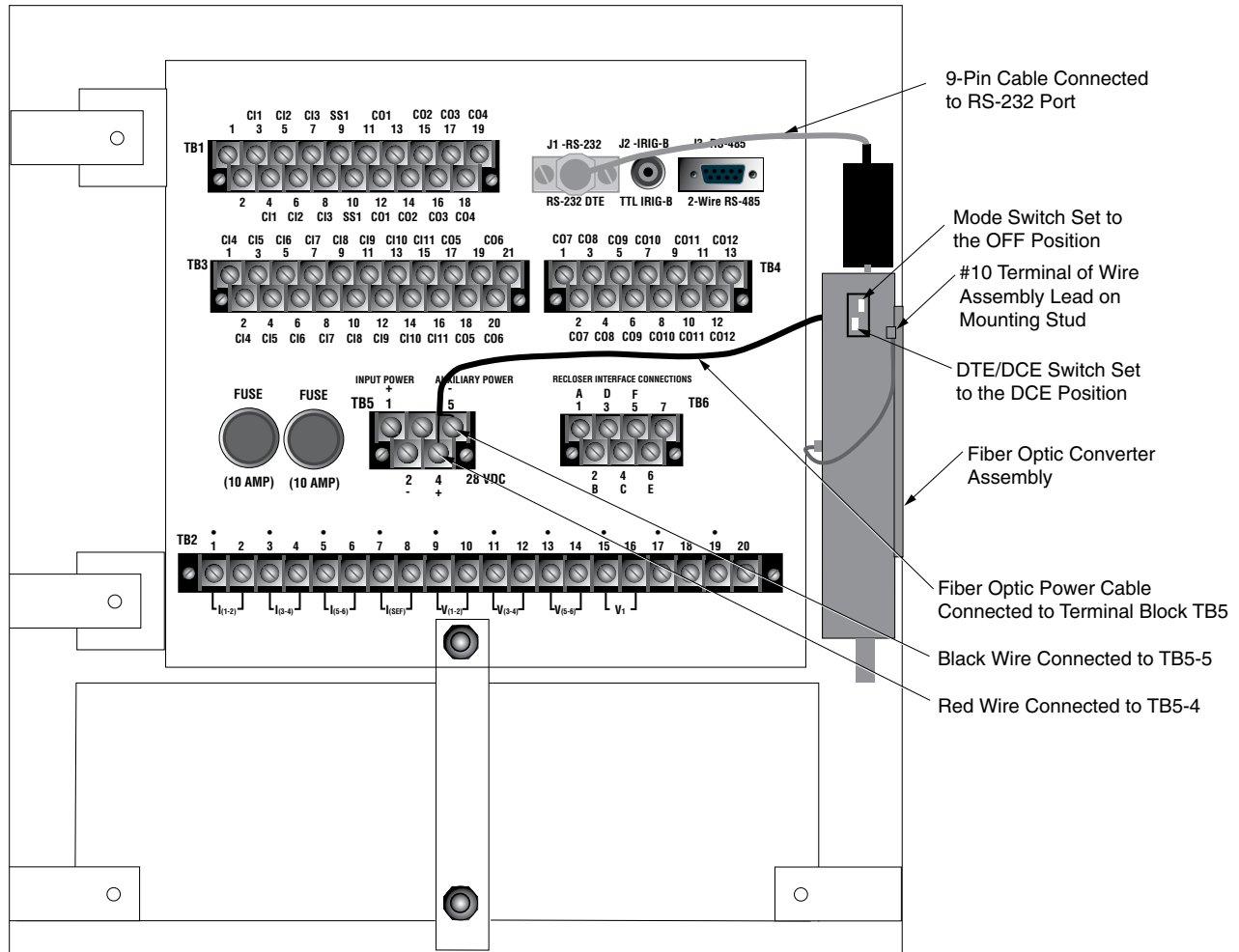

Figure 4. KME6-1875-2 fiber optic converter installed in the Form 6 yard mount recloser control cabinet

## KME6-1875-3 fiber optic converter kit for form 6 rack mount control

### Installation instructions

Refer to Table 3 and Figures 6, 7, and 8 and follow this procedure to install the KME6-1875-3 fiber optic converter kit on the Form 6 rack mount recloser control.

#### CAUTION

**Recloser misoperation. The control must be removed from service prior to performing any maintenance, testing, or programming changes. Failure to comply can result in misoperation (unintentional operation) of the recloser.**

T216.2

1. Remove the Form 6 rack mount recloser control from service.

Refer to *Service Information MN280075EN Form 6 Microprocessor-Based Rack Mount Recloser Control Installation and Operation Instructions* for the procedure **Remove the Control from Service**.

**Note:** The entire kit installation process should take place where the Form 6 rack mount control is installed.

2. Verify the fiber optic converter DTE/DCE switch is set to the DCE position and the mode switch is in the OFF position.

**Note:** The mode switch enables the repeater function in the REP position and disables it in the OFF position.

#### WARNING

**Hazardous voltage. Solidly ground all equipment. Failure to comply can result in death, severe personal injury, and equipment damage.**

T223.2

3. Ground fiber optic converter to Earth with customer-supplied #6 grounding lug.
4. Connect the loose end of the 9-pin cable assembly to the RS-232 port and tighten.

#### CAUTION

**Control damage. De-energize both ac and dc power prior to removing or installing any internal connections or circuit boards in the control. Failure to comply can result in damage to the control.**

T241.1

#### CAUTION

**Equipment damage. Always wear a grounding wrist strap to control static electricity before handling circuit boards. Failure to use this strap may result in circuit board damage.**

T253.1

5. Connect the loose end of the fiber optic power cable. Choose one of these two options:

**OPTION 1.** Connect to customer-supplied 24 Vdc (non-polarized) power source.

or

**OPTION 2.** Connect to Terminal Block TB5:

- A. Connect the black wire to TB5-5.
- B. Connect the red wire to TB5-4.

**Note:** The RS-232 and power cables are six feet in length. This is the maximum distance the user can mount the assembly from the control. Refer to Figure 8 for mounting dimensions.

#### CAUTION

**Equipment misoperation. Do not connect this control to an energized recloser until all control settings have been properly programmed and verified. Refer to the programming information for this control. Failure to comply can result in control and recloser misoperation, equipment damage, and personal injury.**

G110.3

6. Verify the RS-232 and RS-485 Communication Ports are set for the intended protocol:

- Modbus
- DNP3 Protocol, Level 2
- 2179

The RS-232 and RS-485 data ports can be specified with DNP3, 2179, or Modbus protocol. The protocol is user-configured to either the RS-232 or RS-485 serial ports via the ProView interface software.

Refer to the **Communications Workbench™** section of *Service Information S280-70-4 Form 6 Microprocessor-Based Recloser Control Programming Guide* for additional information.

#### CAUTION

**Equipment misoperation. Do not energize this equipment until all control settings have been properly programmed and verified. Refer to the electronic control installation manual for programming procedures. Failure to comply can result in misoperation (unintended operation), equipment damage, and personal injury.**

G119.2

7. Return the Form 6 rack mount recloser control to service.

Refer to *Service Information MN280075EN Form 6 Microprocessor-Based Rack Mount Recloser Control Installation and Operation Instructions* for the procedure **Return the Control to Service**.

**Table 3. KME6-1875-3 form 6 rack mount recloser control fiber optic converter kit parts**

Item	Description	Quantity
1	Fiber optic converter assembly	1

Form 6 recloser control KME6-1875-1, KME6-1875-2, and KME6-1875-3 fiber optic converter kits installation instructions

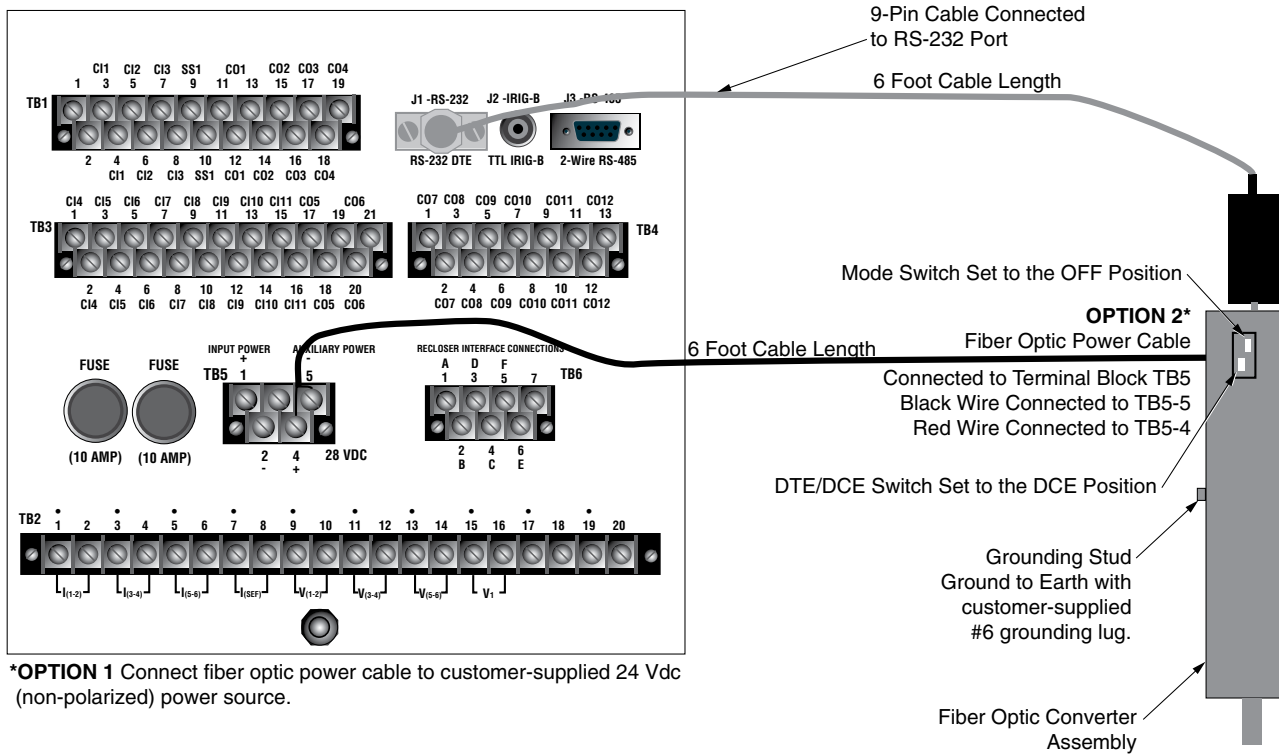

Figure 5. KME6-1875-3 fiber optic converter connected to the Form 6 rack mount recloser control

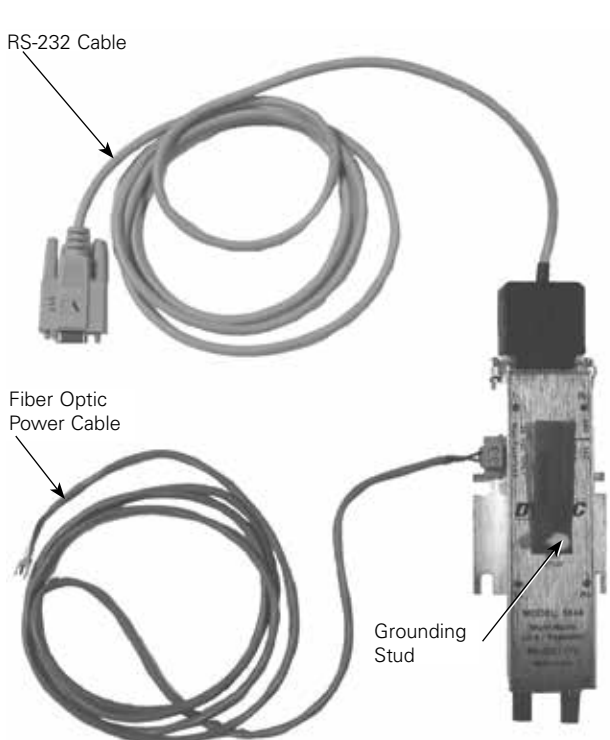

Figure 6. KME6-1875-3 fiber optic converter assembly parts identification

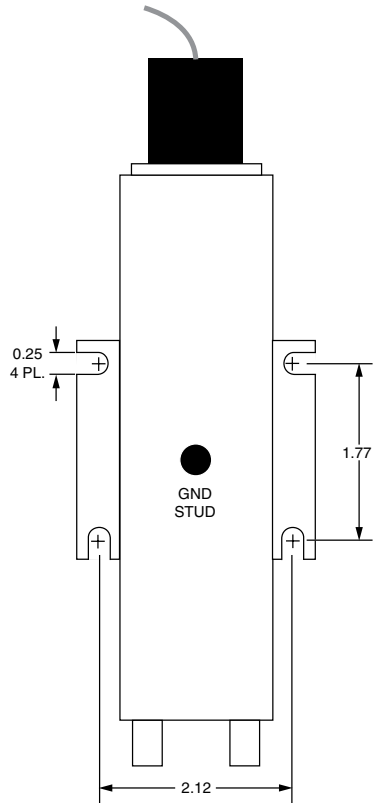

Figure 7. KME6-1875-3 fiber optic converter mounting dimensions (inches).



**Eaton**  
1000 Eaton Boulevard  
Cleveland, OH 44122  
United States  
Eaton.com

**Eaton's Power Systems Division**  
2300 Badger Drive  
Waukesha, WI 53188  
United States  
Eaton.com/cooperpowerseries

© 2017 Eaton  
All Rights Reserved  
Printed in USA  
Publication No. MN280079EN  
KA2048-610 Rev.01  
May 2017

Eaton is a registered trademark.

All trademarks are property  
of their respective owners.

For Eaton's Cooper Power series product  
information  
call 1-877-277-4636 or visit:  
[www.eaton.com/cooperpowerseries](http://www.eaton.com/cooperpowerseries).