

Form 6 microprocessor-based pole-mount recloser control installation and operation instructions

For Type F6-P2A Control, and Type F6-P2B Control, above Serial Number 10,000 or beginning with CP57.

- F6-P2A applies to Form 6 control for use with W, VS, and auxiliary-powered NOVA reclosers.
- F6-P2B applies to control-powered NOVA Form 6 control for use with control-powered reclosers.



DISCLAIMER OF WARRANTIES AND LIMITATION OF LIABILITY

The information, recommendations, descriptions and safety notations in this document are based on Eaton Corporation's ("Eaton") experience and judgment and may not cover all contingencies. If further information is required, an Eaton sales office should be consulted. Sale of the product shown in this literature is subject to the terms and conditions outlined in appropriate Eaton selling policies or other contractual agreement between Eaton and the purchaser.

THERE ARE NO UNDERSTANDINGS, AGREEMENTS, WARRANTIES, EXPRESSED OR IMPLIED, INCLUDING WARRANTIES OF FITNESS FOR A PARTICULAR PURPOSE OR MERCHANTABILITY, OTHER THAN THOSE SPECIFICALLY SET OUT IN ANY EXISTING CONTRACT BETWEEN THE PARTIES. ANY SUCH CONTRACT STATES THE ENTIRE OBLIGATION OF EATON. THE CONTENTS OF THIS DOCUMENT SHALL NOT BECOME PART OF OR MODIFY ANY CONTRACT BETWEEN THE PARTIES.

In no event will Eaton be responsible to the purchaser or user in contract, in tort (including negligence), strict liability or otherwise for any special, indirect, incidental or consequential damage or loss whatsoever, including but not limited to damage or loss of use of equipment, plant or power system, cost of capital, loss of power, additional expenses in the use of existing power facilities, or claims against the purchaser or user by its customers resulting from the use of the information, recommendations and descriptions contained herein. The information contained in this manual is subject to change without notice.

Contents

DISCLAIMER OF WARRANTIES AND LIMITATION OF LIABILITYii

SAFETY FOR LIFEiv

SAFETY INFORMATIONiv

Safety instructionsiv

PRODUCT INFORMATION1

Introduction 1
Read this manual first 1
Additional information 1
ANSI standards 1
Quality standards 1
Acceptance and initial inspection 1
Handling and storage 1
Control power 1
Battery replacement and disposal 1
Operation upon loss of AC power 2

FORM 6 RECLOSER CONTROL DESCRIPTION2

Description 2
Theory of operation 3
Control front panel 3
Control features 9
Communications 12
Control information 13
Control back panel 13

INSTALLATION PROCEDURE13

Initial programming prior to installation 13
Control/recloser compatibility 13
Duty cycle monitor 14
Mounting the control 14
Locking the control 14
Control cable 16
Grounding the control 16
Customer connections for AC power 18
Before placing the control and the recloser into service 27
Using removable inserts 28

ACCESSORIES29

Low voltage closing 29
Internal voltage sensing 29
Incoming power receptacles 29
Cable locking sleeves 29
120 VAC GFI duplex outlet 29
BCT terminal blocks accessory 38
Auxiliary terminal block accessory 38
Cabinet ordering accessories 38
Discrete interface board (DIF) option accessory . . 38
Radio mounting accessory 38
Communication board accessories 39

TESTING41

Testing an installed control 41
Remove the control from service 42
Preliminary testing with no AC available 42
Testing with type MET tester 43
Closing the recloser during testing 43
Battery test and charging procedures 46
Return the control to service 48

RECLOSER VTC INTERFACE49

CONTROL VTC INTERFACE49

ADDITIONAL INFORMATION50

Replacement kits 50
Factory-authorized service centers 50
Factory maintenance classes 50

Form 6 microprocessor-based pole-mount recloser control



Safety for life



Eaton meets or exceeds all applicable industry standards relating to product safety in its Cooper Power™ series products. We actively promote safe practices in the use and maintenance of our products through our service literature, instructional training programs, and the continuous efforts of all Eaton employees involved in product design, manufacture, marketing, and service.

We strongly urge that you always follow all locally-approved safety procedures and safety instructions when working around high-voltage lines and equipment, and support our “Safety For Life” mission.

Safety information

The instructions in this manual are not intended as a substitute for proper training or adequate experience in the safe operation of the equipment described. Only competent technicians who are familiar with this equipment should install, operate, and service it.

A competent technician has these qualifications:

- Is thoroughly familiar with these instructions.
- Is trained in industry-accepted high- and low-voltage safe operating practices and procedures.
- Is trained and authorized to energize, de-energize, clear, and ground power distribution equipment.
- Is trained in the care and use of protective equipment such as arc flash clothing, safety glasses, face shield, hard hat, rubber gloves, clampstick, hotstick, etc.

Following is important safety information. For safe installation and operation of this equipment, be sure to read and understand all cautions and warnings.

Hazard Statement Definitions

This manual may contain four types of hazard statements:

DANGER

Indicates an imminently hazardous situation which, if not avoided, will result in death or serious injury.

WARNING

Indicates a potentially hazardous situation which, if not avoided, could result in death or serious injury.

CAUTION

Indicates a potentially hazardous situation which, if not avoided, may result in minor or moderate injury.

NOTICE

Indicates a potentially hazardous situation which, if not avoided, may result in equipment damage only.

Safety instructions

Following are general caution and warning statements that apply to this equipment. Additional statements, related to specific tasks and procedures, are located throughout the manual.

DANGER

Hazardous voltage. Contact with hazardous voltage will cause death or severe personal injury. Follow all locally-approved safety procedures when working around high- and low-voltage lines and equipment.

G103.3

WARNING

Before installing, operating, maintaining, or testing this equipment, carefully read and understand the contents of this manual. Improper operation, handling, or maintenance can result in death, severe personal injury, and equipment damage.

G101.0

WARNING

This equipment is not intended to protect human life. Follow all locally-approved procedures and safety practices when installing or operating this equipment. Failure to comply can result in death, severe personal injury, and equipment damage.

G102.1

WARNING

Power distribution and transmission equipment must be properly selected for the intended application. It must be installed and serviced by competent personnel who have been trained and understand proper safety procedures. These instructions are written for such personnel and are not a substitute for adequate training and experience in safety procedures. Failure to properly select, install, or maintain power distribution and transmission equipment can result in death, severe personal injury, and equipment damage.

G122.2

WARNING

Overlapping zones of protection are required. Upstream protection device settings must provide adequate overcurrent protection in the event of a system or product failure. Failure to properly select appropriate upstream coordination protection can result in death, severe personal injury, and equipment damage.

G172.0

Product information

Introduction

Service Information *MN280077EN* provides installation and operation instructions for the Form 6 pole-mount recloser control above serial number 10,000 or beginning with CP57.

Refer to the following information as appropriate for your version of ProView software:

- *Service Information S280-70-4 Form 6 Recloser Control Programming Guide: ProView 4.X.X software*
- *Service Information S280-70-21 Form 6 Recloser Control Programming Guide: ProView 5.X.X software*

Read this manual first

Read and understand the contents of this manual and follow all locally approved procedures and safety practices before installing or operating this equipment.

Additional information

These instructions cannot cover all details or variations in the equipment, procedures, or process described, nor provide directions for meeting every possible contingency during installation, operation, or maintenance. When additional information is desired to satisfy a problem not covered sufficiently for the user's purpose, contact your Eaton representative.

ANSI standards

Eaton Cooper Power series reclosers are designed and tested in accordance with the following ANSI standards: C37.60 and C37.85 and ANSI Guide C37.61.

Quality standards

ISO 9001-Certified Quality Management System

Acceptance and initial inspection

Each Form 6 recloser control is completely assembled, tested, and inspected at the factory. It is carefully calibrated, adjusted and in good condition when accepted by the carrier for shipment.

Upon receipt, inspect the carton for signs of damage. Unpack the control and inspect it thoroughly for damage incurred during shipment. If damage is discovered, file a claim with the carrier immediately.

Handling and storage

Be careful during handling and storage of the control to minimize the possibility of damage. If the control is to be stored for any length of time prior to installation, provide a clean, dry storage area. If storage is in a humid atmosphere, make provisions to keep the control circuitry energized.

Note: To energize the control, apply AC power to the AC supply input terminal block located in the lower right hand corner of the back panel of the control. Refer to the **Customer connections for AC power** section in this manual.

Control battery storage and charging

The 24 VDC control battery in the Form 6 recloser control is fully charged prior to shipment and is ready for use.

IMPORTANT

To maintain sufficient charge to operate the control and prevent battery cell damage, the sealed lead-acid batteries should be charged after no more than three months of storage.

Temperature has an effect on battery life. Sealed lead acid batteries should be stored, fully charged, at room temperature. Never store lead acid batteries at temperatures exceeding 47 °C (117 °F), as damage can result in approximately one month.

The batteries must be tested and charged for 24 hours following every three months of storage from the last test date. A separate portable charger accessory is available. Catalog Number KA43ME7001 provides a 120 Volt battery charger to power individual batteries.

IMPORTANT

Connect the control battery before ac power is connected to the control's AC supply Input Terminal Block. The battery must be disconnected prior to shipping or storing the control.

Note: When shipped from the factory, the battery source is disconnected and its output plugs are taped to the cabinet. Connect the battery plugs into the mating connectors to complete the battery circuit.

Control power

The control is powered from 120 or 240 VAC. The selector switch on the power supply board allows the user to select between 120 VAC or 240 VAC.

Note: The selector switch is factory-set for each control based upon the customer order requirement.

Battery replacement and disposal

The 24 VDC control battery has a life expectancy of four years. It is recommended that the battery be replaced after four years or if the battery fails a battery test - whichever occurs first.

Note: Battery life is decreased at higher temperatures.

Dispose expired batteries in an environmentally responsible manner. Consult local regulations for proper battery disposal.

Form 6 microprocessor-based pole-mount recloser control

Operation upon loss of AC power

The control is equipped with either an 8 Amp-Hour or 13 Amp-Hour 24 VDC lead acid battery for operation upon loss of AC power. The control maintains full operation from the battery for a period of time dependent upon the battery size:

- 8 Amp-Hour — 12 hour maximum (20°C)
- 13 Amp-Hour — 24 hour maximum (20°C)

In the event that the AC power has not returned within the times listed above, the control will disconnect the battery from the circuit.

Note: The control continuously monitors the battery voltage. To prevent battery damage, the control shuts down automatically upon detection of low battery voltage (below 22 VDC) for 60 seconds.

Control programming settings and parameters—including event recorder—are stored in non-volatile memory and retained upon loss of control power. The time/date clock will continue to operate for approximately 30 days after loss of control power.

Phase B (Ø) is the factory default phase. Unless changed by the user, the B PHASE VOLTAGE red LED illuminates indicating AC is the operating power. If BØ (or the user-indicated phase) loses AC power, the ALARM red indicator LED will illuminate. The ALARM log on the LCD Display will indicate NO AC PRESENT and the CONTROL OK LED will not be illuminated.

IMPORTANT

If the the control shuts down due to low battery voltage before AC power is restored, and the connected energized recloser is CLOSED; it will only TRIP and LOCKOUT via front panel pushbutton command.

A control that has shut down due to low battery voltage before AC power is restored will have a blank LCD display (no text message shown) and none of the LEDs will be illuminated.

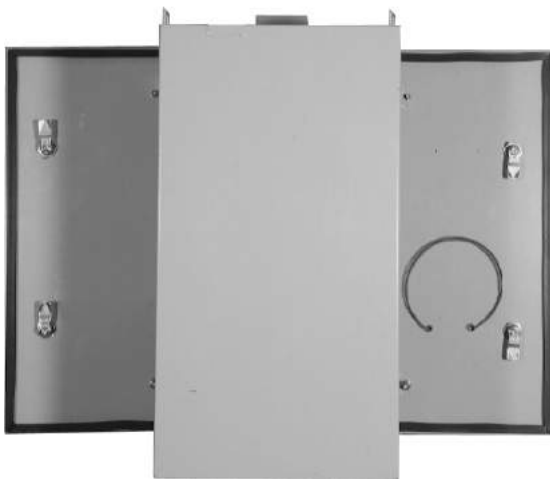

Figure 1. Form 6 pole-mount recloser control is accessible from both the front and back of the cabinet

The control clock may require resetting if the operating power has been disconnected for more than thirty days. Refer to *Service Information S280-70-4 (ProView 4.X.X) or S280-70-21 (ProView 5.X.X) Form 6 Microprocessor-Based Recloser Control Programming Guide* for information on setting the control clock.

Note: When AC power is present, the control will operate regardless of back-up battery presence.

Form 6 recloser control description

Description

The Form 6 pole-mount microprocessor-based recloser control includes extensive system protection functionality, including phase, ground, and negative sequence overcurrent protection, over/underfrequency, and voltage protection, directionality, sensitive ground fault, and sync check.

Analysis tools include fault locating, event recording, TCC Editor II, Idea Workbench, Data Profiler, and oscillography functions, including oscillography replay.

Metering functions include demand and instantaneous current on a per-phase basis, instantaneous voltage and power factor on a per-phase basis, and power (real, reactive, apparent) on a per phase or total basis. Symmetrical components for both voltage and current are displayed along with kilowatt-hours for energy metering. Harmonics from the 2nd to the 15th harmonic are also included.

The front panel LCD display is used to configure the operating settings for the control. It is also used to display metering, counter information, control parameters, reset alarms, and provide diagnostic information.

Control parameters can also be programmed via a personal computer connected to the control through the front panel RS-232 port. Control programming, interrogation, and operations are performed with Form 6 ProView interface software on a personal computer.

ProView interface program software includes additional functions used to create and graphically display Time Current Curves and provides the Idea Workbench for configuring user-selected inputs and outputs, configurable event and alarm data, and selectable communication points for serial communication.

The control operates on 50 and 60 Hz systems.

The control can be configured, by the factory or by the user, for a wide variety of applications. If user requirements change, the control functions can be modified to meet the new requirements.

The control is accessible from both the front and back of the cabinet (**Figure 1**).

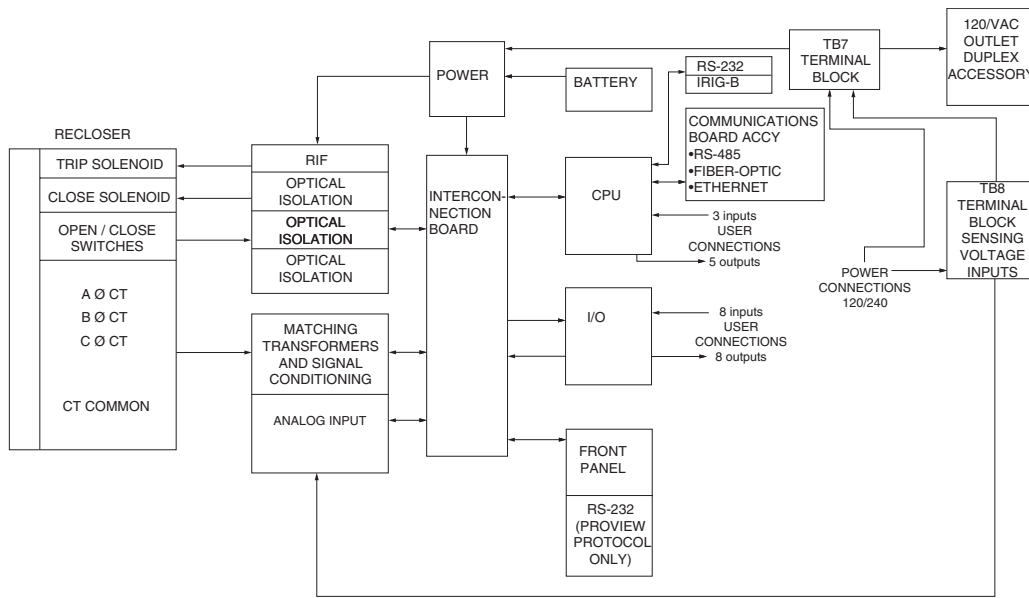

Figure 2. Form 6 pole-mount recloser control operational flow diagram

Theory of operation

A functional block diagram of the Form 6 recloser control is shown in **Figure 2**. Current sensing is provided by three current transformers located in the recloser and interfaced to the Form 6 recloser control via the control cable. This cable also supplies Trip, Close, and Recloser status, and connects to the Recloser Interface (RIF) module to provide isolation for reliable operation. Voltages for metering are connected to the analog input module through terminal block TB8.

Line current flowing through the recloser is converted by the CPU module to a digital signal suitable for metering and fault current calculations. Data sampling occurs at a rate of 64 times per cycle. The CPU contains a data acquisition section that uses the acquired samples to compute the fundamental currents and voltage for use in overcurrent, under/overvoltage, and under/overfrequency protection, as well as currents and voltages for metering functions. The current for overcurrent protection is calculated on a sub-cycle basis; it includes only the fundamental and DC component.

When the phase or ground current exceeds its programmed minimum-trip value and associated time-current-curve (TCC) timing, the control initiates the programmed sequence of recloser tripping and reclosing operations via the CPU and RIF modules. If the fault is temporary, the control ceases to command recloser operations after a successful reclose, and the control resets to the start of its operating sequence after a preset time delay. If the fault is permanent, the control performs its complete programmed sequence of reclose commands and locks out with the recloser open. Once locked out, the control must be closed via the operator panel or SCADA communications. This resets the control to the start of the operating sequence.

The following chain of events occurs for an operating sequence of two trips to lockout (one trip on TCC1, one trip on TCC2):

1. The overcurrent signal is integrated with time on the selected curve for the first trip operation (TCC1) to produce the signal which energizes the trip circuit.
2. Energizing the trip circuit connects the supply to the trip solenoid to open the recloser.
3. Upon opening, the control starts timing on the first reclosing interval-delay time.
4. Upon expiration of this reclosing interval-delay, a closing signal is issued from the control, closing the recloser, and selecting the time-current characteristics for the second trip operation (TCC2).
5. If current remains above the minimum-trip level, the recloser will trip on TCC2 and lockout the recloser.

Control front panel

The Form 6 control front panel is illustrated in **Figure 3**.

The front panel is separated into two clearly identified, color-coded sections:

- The top portion of the front panel is used for programming the control and providing LED status indication.
- The lower portion of the front operating panel is used for operating the control and recloser.

The control includes a Power Save feature that will turn off the backlit LCD display and all LEDs (except Hot Line Tag) if no front panel keypad is pressed within ten minutes. Pressing the LAMP TEST key will re-activate the display and LEDs.

Form 6 microprocessor-based pole-mount recloser control

Note: The Power Save feature is a ProView interface software default setting. This feature can be disabled via the ProView interface software.

The control includes a Reset Menu feature that will cause the LCD display to revert to the root menu after ten minutes of inactivity.

Note: The ten minute timer and MMI Reset Menu is a ProView interface software default setting. The menu selection and timer can be changed via the ProView interface software.

Front panel text messaging

The LCD messages are accessed from the front panel by following the Text Messages menu path. This menu displays any active user-configured text messages.

Up to fourteen user-configurable text messages can be programmed via the Idea Workbench. Refer to *Service Information S280-70-4 (ProView 4.X.X) or S280-70-21 (ProView 5.X.X) Form 6 Control Programming Guide* for information on programming the text messages.

These text messages appear on the front panel LCD and can be programmed to appear for alarm or other conditions.

Text messages displayed on the front panel are limited to four lines of 20 characters each (including spaces). Text messages can also be accessed by pressing the LAMP TEST one-touch analysis key on the front panel.

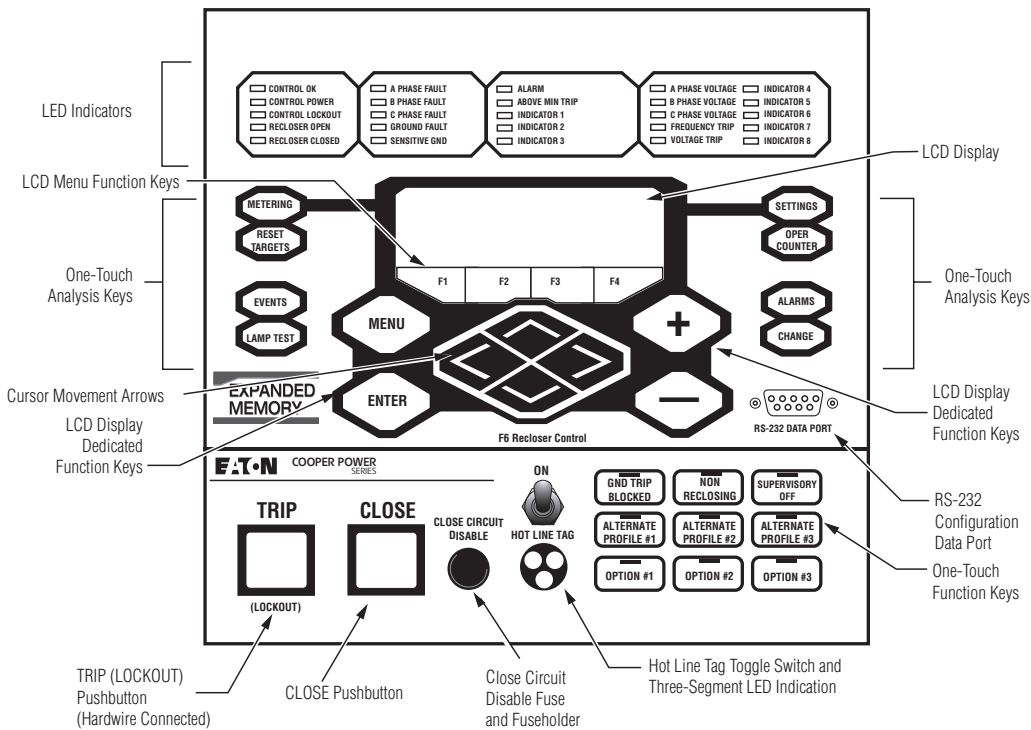

Figure 3. Form 6 pole-mount control front panel

Programming panel

The Programming panel has the following sections:

One-touch analysis keys

There are eight analysis keys (Figure 4) that allow one-button access to a variety of control and monitoring functions that appear in the LCD display. Pressing these buttons causes the following information to display or function to occur:

Note: When pressing a membrane pushbutton, always press and hold for 0.5 seconds to ensure the button press is recognized by the device.

METERING: Displays the systems instantaneous metering values for current and voltage on the LCD display.

RESET TARGETS: Resets the fault target indicators on the operator panel.

EVENTS: Displays the last 25 events from the Sequence of Events log.

LAMP TEST: All operator panel LEDs are illuminated for verification of proper connection and operating status of all indicator lights. All status indicators will then return to their previous state. While in the LAMP TEST mode, the control response to operator panel keys is disabled, except for the TRIP (LOCKOUT), CLOSE, and HOT LINE TAG switches.

SETTINGS: Displays recloser settings on the LCD display.

OPER COUNTER: Displays the total number of trip operations and target counters for each A, B, and C Phase; Ground, and Sensitive Ground on the LCD display.

ALARMS: Provides status information on the LCD display for all recloser alarms.

CHANGE: Allows the user to change the state of the control functions on the operator panel function keys.

Note: The CHANGE mode is a ten second period in which one function setting can be changed. If no change is made in that time, the control returns to the current setting.

LCD Display

The LCD Display is a backlit 4-line, 20-character display that provides extensive distribution system, recloser, and control status information using a minimum of eight navigation keypads (Figure 4).

Note: The LCD display panel contrast is field-adjustable to allow for various mounting heights and applications. Press the MENU key and then press the (+) or (-) key to increase or decrease the contrast.

The four LCD navigation buttons are as follows:

MENU: Identifies the LCD Display menu options.

ENTER: Selects a menu option.

+: Increases value selection.

-: Decreases value selection.

The four LCD menu function keys activate specific menu commands. When a command appears in the LCD display directly above one of the four LCD menu function keys, the user can press the key to accept/select the command.

The four LCD menu function keys are as follows:

F1 F2 F3 F4

The four cursor movement arrows allow movement in the following directions:

- Moves the cursor left.
- Moves the cursor right.
- Moves the cursor up one line.
- Moves the cursor down one line.

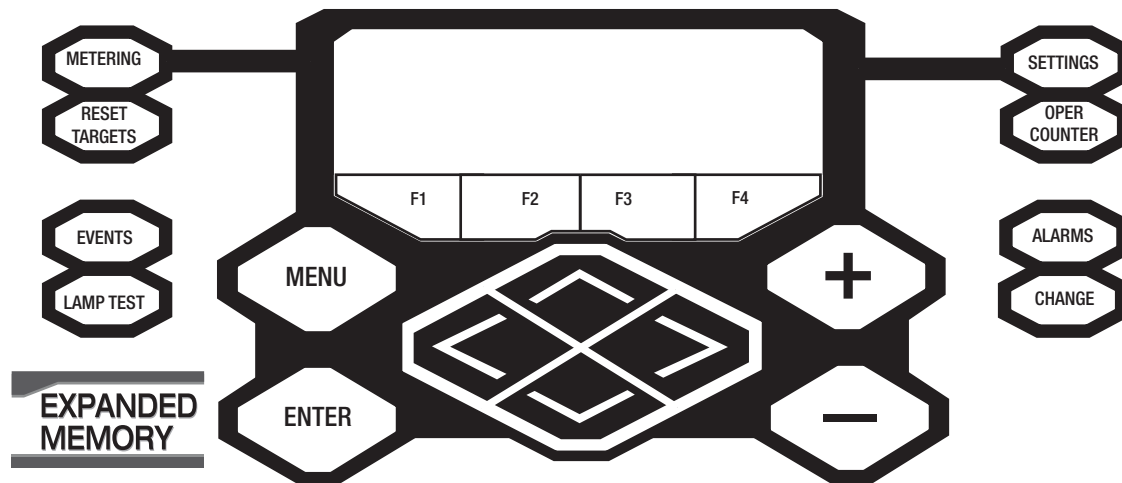

Figure 4. Analysis keys, LCD display, LCD menu function keys, and cursor movement arrows

Form 6 microprocessor-based pole-mount recloser control

Status indicator LEDs

The status indicator LEDs (**Figure 5**) in the Programming section of the Operator Panel give instant information on the control and recloser status:

All of the default status indicators LEDs (except for CONTROL OK, CONTROL POWER, and ALARM) can be reconfigured via the Idea Workbench. Refer to *Service Information S280-70-4 (ProView 4.X.X) or S280-70-21 (ProView 5.X.X) Form 6 Control Programming Guide* for additional information.

The label inserts can be user-customized. Refer to **Using removable inserts** section of this manual for additional information.

CONTROL OK: The green LED indicates the control is operating normally and not in an alarm state.

The CONTROL OK LED will not be illuminated during these alarms (indicated by the red ALARM LED and displayed in the alarm status log):

- **Battery Alarm:** This alarm indicates battery voltage is low or the battery failed an operator-initiated manual test.
- **RAM Failure:** This alarm indicates a failed RAM memory test.
- **ROM Failure:** This alarm indicates a failed ROM memory test.
- **No AC Present:** This alarm indicates AC power was unavailable for 10 continuous seconds. This alarm resets when AC power is restored.
- **Power Supply Malf[unction]:** This alarm indicates internal control operation power was outside of its operating tolerance for more than 20 seconds. This alarm resets when the internal control operation power returns to operation within its normal tolerances.
- **RIF Comm Failure:** This alarm indicates a loss of communication from the RIF (Recloser Interface) circuit board to the main CPU circuit board. This alarm resets if communication is re-established.

CONTROL POWER: The green LED indicates there is adequate VTC voltage to trip the recloser. This LED does not indicate the presence of AC or battery power.

CONTROL LOCKOUT: The green LED indicates the control is in a locked out state, i.e. a reclosing sequence is not in progress. This LED does not indicate that the recloser is open.

RECLOSER OPEN: The green LED indicates the recloser is in the open position.

RECLOSER CLOSED: The red LED indicates the recloser is in the closed position.

Note: There are several conditions that will cause the alternate blinking of the CONTROL LOCKOUT, RECLOSER OPEN, and RECLOSER CLOSED LEDs: Failure to Trip, Failure to Close, Interrupter Malfunction, and 52a/b Disagreement.

The LED blinking pattern for these conditions is the CONTROL LOCKOUT green LED and RECLOSER CLOSED red LED alternating with the RECLOSER OPEN green LED.

In addition to the above LED blinking pattern, the red ALARM LED will also be illuminated for these alarms: Failure to Trip, Failure to Close, and Interrupter Malfunction.

A PHASE FAULT, B PHASE FAULT, C PHASE FAULT: The red LEDs indicate A, B, and/or C phase current was either the maximum phase current or within 20% of the maximum when a trip signal was issued.

GROUND FAULT, SENSITIVE GROUND FAULT: The red LEDs indicate that a Ground and/or Sensitive Earth Fault tripping function was asserted at the time the trip signal was asserted.

ALARM: The red LED indicates an alarm has been issued. Review the alarm status and log on the LCD display for the specific alarm.

ABOVE MINIMUM TRIP: The red LED indicates the current exceeds the level set for minimum trip.

FREQUENCY TRIP: Indicates the recloser tripped due to an under or over frequency condition.

VOLTAGE TRIP: Indicates the recloser tripped due to an under or over voltage condition.

A PHASE VOLTAGE, B PHASE VOLTAGE, C PHASE VOLTAGE: The red LED indicates a presence of voltage on the respective phases. The Single-Phase Undervoltage Pickup setting controls the voltage indication for the front panel LEDs as defined in the Voltage setting dialog box for the active setting profile. Refer to **Settings - Voltage** in the **Schemes** section of *S280-70-4 (ProView 4.X.X) or S280-70-21 (ProView 5.X.X) Form 6 Control Programming Guide*.

INDICATOR 1, INDICATOR 2, INDICATOR 3, INDICATOR 4, INDICATOR 5, INDICATOR 6, INDICATOR 7, INDICATOR 8: Customizable LEDs that are used with functions programmed through the Idea Workbench. The LED indicators do not have active default values. The LEDs are illuminated when the status configured via the Idea Workbench is present.

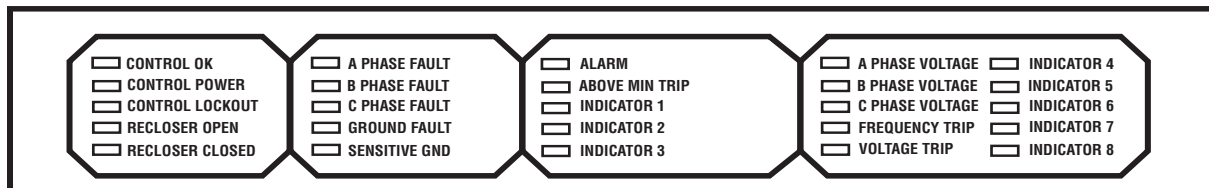

Figure 5. Form 6 pole-mount control status indicator LEDs

Operating panel

RS-232 configuration data port

The RS-232 connector (shown in **Figure 3**) on the front operating panel allows direct connection to a personal computer without any special cables or connectors. This port is used only for configuring the control with ProView application software. All settings, metering, events, and oscillography data are available from this port. The port is Data Communication Equipment (DCE) wired for direct connection to a personal computer.

A 9-pin RS-232 cable (Catalog Number KME5-66) to connect from the PC to the RS-232 data port is available as an accessory.

HOT LINE TAG ON/OFF Toggle Switch and LED Indicator

WARNING

Hazardous voltage. Do not use Hot Line Tag as a substitute for a visible disconnect. Always establish a visible disconnect prior to performing any work requiring a de-energized line. Failure to comply may cause death, severe personal injury, or equipment damage.

T276.0

Hot Line Tag is provided for live-line work applications. All closing operations are disabled when the Hot Line Tag feature is activated.

IMPORTANT

Hot Line Tag activation does not cause the recloser to trip open. It only prevents the recloser from closing.

IMPORTANT

Hot Line Tag is intended solely for live-line work applications, such as maintenance, repairs or improvements to the distribution system, that occur while the line remains energized.

Hot Line Tag prevents all closing attempts from the control and shifts protection to one trip-to-lockout on the composite curve of the Hot Line Tag definite time and the TCC1 curve (whichever is faster). Hot Line Tag takes precedence over Cold Load Pickup, Non-Reclosing, and Fast Trips Disabled.

Hot Line Tag is activated from either the operator panel toggle switch, serial communications, or a discrete SCADA function. All sources must be off to de-activate Hot Line Tag.

To activate the function from the operator panel, flip toggle switch up to the ON position. See **Figure 6**. The LED indicator illuminates when the function is active.

The Hot Line Tag function may only be reset by the source which initiates it. For example, if Hot Line Tag is activated at the operator panel, the reset function is only possible at the operator panel, and not via SCADA command.

IMPORTANT

If the power save feature is enabled (default), and more than ten minutes elapses since the last panel operation, all the LEDs, except HOT LINE TAG (if active), will turn off.

Close circuit disable

Close Circuit Disable (**Figure 6**) is a removable fuse that, when removed from the front operating panel, disables the close circuit from the control to the recloser. Removing the fuse from the control disables all electrical closing of the recloser and provides a physical disconnect to the recloser closing circuit. As a result, the control cannot perform a close operation. This disconnect overrides all close functions and makes a remote or manual close operation impossible.

Note: When the Close Circuit Disable fuse is removed, the trip circuit remains active and will trip per the programmed time current curve for a faulted condition.

IMPORTANT

If the CLOSE button is pressed after the Close Circuit Disable fuse is removed, do not reinstall the fuse until after the ALARM LED illuminates (within approximately five seconds) to indicate CLOSE MALFUNCTION. Re-installing the Close Circuit Disable fuse prior to the CLOSE MALFUNCTION ALARM indication will cause the control to close the recloser.

TRIP (Lockout) Pushbutton

The TRIP pushbutton (**Figure 6**) provides front-panel access to trip (lockout) the recloser. When pressed, the TRIP pushbutton opens the recloser and locks out the control.

Note: In the event of main microprocessor failure, the trip circuit can operate independent of the main microprocessor.

CLOSE pushbutton

When pressed, the CLOSE pushbutton (**Figure 6**) returns the control to the initial or home sequence position, closing the recloser. The control is ready for the start of a new trip/close sequence.

Note: The Close Malfunction alarm must be reset before Closing will be allowed.

Note: Pressing the CLOSE pushbutton from the Lockout position initiates Cold Load Pickup (CLPU) protection, if the feature is enabled.

The user does have the ability to block COLD LOAD PICKUP through the LCD menu or by configuring one of the Option one-touch function keys via the Idea Workbench feature in ProView.

If the recloser is closed, pushing and holding the CLOSE pushbutton does not activate the Cold Load Pickup feature. See **Cold load pickup** in the **Control features** section of this manual.

Form 6 microprocessor-based pole-mount recloser control

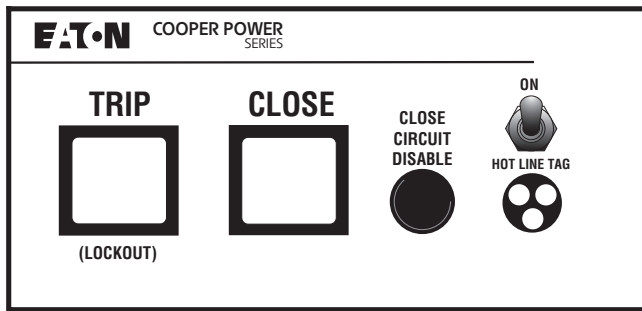

Figure 6. TRIP (Lockout) pushbutton; CLOSE pushbutton; Hot Line Tag switch and Hot Line Tag red indicator LEDs

One-Touch Function Keys

Quick access to frequently operated Form 6 control features is provided with nine function key pushbuttons on the control operator panel.

The Form 6 control operator panel one-touch function keys are illustrated in **Figure 7**.

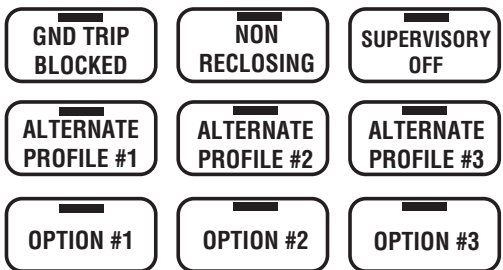

Figure 7. Form 6 pole-mount control operator panel one-touch function keys

Red LEDs located on each function key indicate the status of the function, regardless of local or remote activation. For example, if Ground Trip Blocked is activated from a SCADA signal, the red indicator will illuminate even though it was not activated from the operator panel.

Operator panel function key activation or de-activation requires the operator to first press the CHANGE key to enter the CHANGE mode. A function must then be selected or de-selected within ten seconds to activate or de-activate the function. Once selected, the control returns to normal operation until prompted for another change request. This prevents accidental changing of functions or features.

Note: Only one function can be changed per each CHANGE mode activation.

GND TRIP BLOCKED

The Ground Trip Blocked function blocks all ground sensing in the control for the active profile. This red indicator is illuminated when Ground Trip Block is activated from the serial port, I/O, the interface software, or locally (via the front panel) causing the control to block all ground sensing.

NON RECLOSING

The control is operating in a non-reclosing mode when the NON RECLOSING red indicator is illuminated. Non-reclosing

mode disables any automatic reclosing operations. Non-reclosing does not alter the active TCC. Activation is possible from the SCADA port, I/O, the interface software, or locally (via the front panel).

SUPERVISORY OFF

When the SUPERVISORY OFF red indicator is illuminated, supervisory commands are blocked. Supervisory functions through the back panel serial communication ports and the discrete I/O are blocked. Serial communications through the front panel RS-232 port remain active independent of the status of the SUPERVISORY OFF switch. Activation of this function key is restricted to the operator panel and is accomplished by pressing the CHANGE key and then pressing the SUPERVISORY OFF key. Operational data and metering information are available while the control is in the SUPERVISORY OFF position. The TRIP and CLOSE pushbuttons and Hot Line Tag are active independent of the SUPERVISORY OFF function.

ALTERNATE PROFILE #1, #2, AND #3

The Form 6 control has four separate protection profiles; a normal profile, and Alternate Profiles 1, 2, and 3. Each profile changes all protection parameters for the control. Except for the normal profile, each has an indication and selection key. When the operator panel display lights are active and none of the three indicators are on, the normal profile is active. Only one profile can be active.

To select an alternate profile, press the CHANGE key and then press the desired alternate profile.

To return to the normal profile, press the CHANGE key and then press the active alternate profile to deselect it. These functions can also be completed remotely via communications interfaces.

IMPORTANT

Unused alternate profiles should be programmed with the same settings as one of the applicable profiles. Default settings on unused alternate profiles can cause unnecessary outages if they are below normal system requirements.

IMPORTANT

Check minimum trip values prior to changing an alternate profile to avoid misoperation of the control under load conditions.

OPTION #1, OPTION #2, AND OPTION #3

The OPTION #1, OPTION #2, and OPTION #3 function keys must be programmed via the ProView Idea Workbench software.

The OPTION LEDs are illuminated when the options configured via the Idea Workbench are selected. Refer to *Service Information S280-70-4 (ProView 4.X.X) or S280-70-21 (ProView 5.X.X) Form 6 Control Programming Guide* for additional information.

These OPTION keys provide a momentary signal. For instance, these keys can be programmed to toggle control status, protective functions, or a momentary input pulse.

The OPTION #1, OPTION #2, and OPTION #3 function keys are intentionally not defaulted to any function. The functions are assigned to each OPTION key via the Idea Workbench application.

Control features

The Form 6 pole-mount recloser control offers numerous standard features and accessories that allow the user the utmost flexibility applying the recloser control.

Control security

The Form 6 pole-mount recloser control has multiple customer-programmable security codes to limit control programming and viewing function access to authorized personnel. The front panel Man-Machine Interface (MMI) includes a user-selected security code to access the settings. Plus, the ProView interface software has its own security levels for multiple-user access.

Refer to *Service Information S280-70-4 (ProView 4.X.X) or S280-70-21 (ProView 5.X.X) Form 6 Microprocessor-Based Recloser Control Programming Guide* for additional information.

Protection profiles

Four protection profiles capable of fully specifying control operation are standard in the control. Each protection profile includes the following as a minimum:

- Overcurrent Protection
- Over/Undervoltage Protection
- Over/Underfrequency Protection
- Directional Protection
- Hot Line Tag Functionality
- Sync Check
- Sensitive Earth Fault Protection
- Sequence Coordination
- Operation Settings

Time current curves

Time-current curves are available for numerous functions, including fast and delayed operations for phase, ground, and negative sequence protection. Each time-current is selected from a defined fifty curves which can be further customized by the user. The time-current curves are also selected from a graphical TCC Editor II to visualize any modifications prior to configuring the control.

The time-current curves include the following modifications for phase, ground, and negative sequence protection:

- Time Multiplier with a range of 0.1 to 25 in .1 increments.
- Time Adder with a range of 0 to 30 seconds in .01 second increments.

- Minimum Response Time with a range of 0.01 to 1 seconds in .001 second increments.
- High Current Trip multiplier with a range of 1 to 32 multipliers in increments of 0.1.
- High Current Trip Time Delay with a range of 0.01 to .150 second in .001 second increments.
- Time Dial Reset co-efficient with a range of .1 to 30 seconds in 1 second increments.

Sequence coordination

Sequence Coordination eliminates nuisance tripping through trip coordination. It allows the control to step through selected operations in the operating sequence without tripping. The number of Sequence Coordination advances is programmable from one to three operations to provide trip coordination with a downline recloser. This feature is independently selectable for each protection profile.

Cold load pickup

The control includes a Cold Load Pickup feature to prevent the control from tripping while energizing non-fault system loads. This feature has independently programmable minimum trip value time-current curve, reclose interval, and number of independent operations to lockout for each protection profile. Cold Load Pickup also includes TCC Multipliers, TCC Adders, Minimum Response Time, Time Dial Reset, and High Current Lockout. Also, direct values, not multiples of minimum trip, are provided for high current lockout.

Fast trips disabled

The control includes a Fast Trips Disabled feature to modify protection, so that all trip operations use the programmed TCC2. This feature is independently selectable for each protection profile. All trip operations will time on TCC2. Typically, TCC1 is fast and TCC2 is delayed. So, as an example, the control will change its sequence from 2 fast and 2 delayed operations to 2 operations on TCC2 when Fast Trips Disabled is active.

High current lockout

The High Current Lockout feature will automatically lockout the control on the selected operation when current exceeds a programmable level. The active trip numbers for the lockout is selectable for phase, ground, and negative sequence. This feature is independently selectable for each protection profile.

Sensitive ground/earth fault operation

The control has a Sensitive Ground/Earth Fault Trip feature that provides tripping of the recloser after a programmable, definite time for ground currents below normal ground minimum trip levels. The feature has programmable operations to lockout and reclose intervals independent of the ground settings. This feature is independently selectable for each protection profile.

Form 6 microprocessor-based pole-mount recloser control

Thermostatically controlled heater

The control has a standard 15 Watt thermostatically controlled heater (ON 70°F, OFF 85°F) for humidity control and voltage input independent. The heater is powered from the power supply board.

Metering

The control provides instantaneous and/or demand metering with programmable integration intervals for the following functions:

- Real and reactive power for each phase and total, including directional, on an individual phase basis.
- Demand currents on a per phase basis.
- Instantaneous currents, including ground current.
- Instantaneous voltage on a per phase basis.
- Instantaneous frequency.
- Positive, negative, and zero sequence voltages.
- Instantaneous power factor on a per phase basis.
- Metering settings to include demand interval, and alarm thresholds for current, single-phase kW, three-phase kW, single-phase kvar, and three-phase kvar.

Event recorder

The Form 6 control contains capabilities to perform Sequence of Events time-stamping for up to 33 event types. Sixteen additional inputs can be user-defined through the Idea Workbench.

Factory-defined event types include:

- Overcurrent Protection Trip
- External Trip
- Non-Reclose Trip
- External Close
- Lockout
- Reset

The Event Recorder maintains a minimum of 90 event records. The last 25 events are viewable on the front panel LCD display. Refer to *S280-70-4 (ProView 4.X.X)* or *S280-70-21 (ProView 5.X.X) Form 6 Control Programming Guide* for additional information.

Recloser duty monitor

The Form 6 recloser control software is equipped with a Recloser Interrupting Duty Monitor. The Duty Monitor accumulates the summation of I1.5 for all interrupted currents on each interrupter. This feature permits programmable entries to preset the duty of an existing recloser. The recloser duty monitor displays interrupting duty in percent of duty used. If the duty cycle monitor exceeds 100%, the recloser should be examined for maintenance.

Discrete SCADA communications

The control provides five configurable output status contacts and three configurable input control contacts as standard. Each status contact is configurable using graphical interface software to combine status functionality along with Boolean algebra. Default output status contacts are: Lockout, Recloser Open, Recloser Closed, Ground Trip Block, and Hot Line Tag. One output status contact is a solid state output (SS1) with a pickup time no longer than two milliseconds.

The control also provides a minimum of three configurable input control contacts. Each control contact is configurable using a graphical interface software. Contacts accept a wetting voltage range of 12–250 VDC, 120/240 VAC. Each digital input is configured for either a momentary, maintained, or maintained with precedence contact. Default input control contacts are: Supervisory Trip and Lockout, Supervisory Close, and Remote Trip and Lockout.

A Discrete Interface Board is also available as an accessory to provide an additional eight output status contacts and eight input control contacts. The expansion I/O board is completely user-configurable.

TCC Editor II

Coordination and actual time current modifications are available with a graphic interactive TCC Editor or similar graphical software.

The TCC Editor II includes a complete database of standard recloser industry time current curves (TCC), both ANSI and IEC types, along with the ability to customize the TCCs with multipliers, constant time adders, or minimum response time adders. Also, the user is able to derive their own specific TCC through data point entry. Each modified time current curve can be identified with a user-customized name and is selectable for configuring the control. The grid and format for presenting the TCCs has a user-adjustable scale, including the option of presenting multiple TCCs in various user-configured colors.

Oscillography

Oscillography is provided to present current and voltage waveforms, along with protection element and recloser response status changes. Filtered and unfiltered data are provided for viewing.

The recorded values are super-imposed on the protection scheme, and the state or value at any point in the scheme is displayed. The user has the capability to move through the event and watch the response of every function. All analog signals, digital inputs, and contact outputs are monitored. Analog oscillography is displayed at 16 samples per cycle.

Oscillographic data is recorded to analyze multiple events during a permanent fault or other event type. The oscillographic data shows two cycles before the trigger point and eight cycles after the trigger point (default).

Note: The configuration settings are programmable.

Oscillography automatically initiates trigger points for the following functions:

- Above Minimum Trip for Phase, Ground, and Sensitive Ground Fault
- Single- and Three-Phase Overvoltage
- Single- and Three-Phase Undervoltage
- Over- and Underfrequency
- Trip Signal Issued
- Close Signal Issued

Removable inserts

Removable inserts are included with the control design for customization of specific protection requirements. Inserts are available for the status indicator LEDs, the operator panel function keys, and the analysis keys. The removable inserts are designed for use without adhesives, labelmakers, or temporary labels. Refer to **Using removable inserts** for more information.

An electronic label template is included on the ProView application software CD and can be accessed through the following default address: C:\Program Files\Cooper\ProviewXX\Form 6\Form 6 Inserts.doc

Idea workbench

The Idea Workbench provides access to various inputs, intermediate variables, and internal Form 6 alarms, status, and targets to allow user-customization of the Form 6 recloser control to meet specific and unique applications. The Idea Workbench also gives the user the ability to perform logical functions with these variables by using a simple graphical user interface. Use of the Idea Workbench is not a requirement for operation.

Refer to *Service Information S280-70-4 (ProView 4.X.X) or S280-70-21 (ProView 5.X.X) Form 6 Microprocessor-Based Recloser Control Programming Guide* for additional Idea Workbench information.

Over/underfrequency protection

The control includes two-stage operation for both underfrequency and overfrequency protection. A fixed time delay ranging from 0 to 100 seconds in .001 second increments is available for both over and underfrequency. A frequency restoration function, enabled or disabled by the user, is provided to allow the recloser to automatically close should frequency return to within configured settings for a user-settable time. Over/Underfrequency Protection is included as part of each protection profile.

Over/undervoltage protection

The control includes single-phase and three-phase under voltage tripping. The control also includes three-phase overvoltage tripping. Both over and undervoltage functions include a single-phase and three-phase pick-up setting; a single-phase and three-phase time delay setting ranging from 0 to 100 seconds.

Directional

Directional functionality is included to maintain system coordination from multiple sources, as well as circuit reconfiguration for each profile. Directional applies to phase, ground, and negative sequence protection, selected independently. A maximum torque angle has a range of 0 – 90 degrees.

Fault location

The control includes an impedance-based fault locator based upon the Takagi algorithm¹. Load-compensated impedance calculation is used for calculating the distance. Positive and zero sequence is configured in ohms, and the fault locator line length is configured in kilometers/miles.

¹T. Takagi, Y. Yamakoshi, J. Baba, K. Uemura, T. Sakaguchi, "A New Algorithm of an Accurate Fault Location for EHV/UHV Transmission Lines: Part I - Fourier Transformation Method," IEEE Trans. on PAS, Vol. PAS-100, No. 3, March 1981, pp 1316-1323.

Sync check

Sync Check is a permissive system used to qualify any close signal to the mechanism when enabled via the sync check settings. Sync check allows for closing for any combination of dead/live bus/line, and to perform anticipatory closing for a live bus/live line condition by calculating slip and anticipating the mechanism closing delay. In addition to the anticipatory close calculation, the sync check system performs verification of line and bus voltage magnitudes and frequencies to determine that they are within pre-determined ranges, and that the angular difference between the two systems is also within the pre-determined range. For a live/live close, where there is no slip between the systems, the sync check system allows permissive closing after the two systems are within frequency and voltage limits, and the angular difference between the systems has been within the allowable limits for a pre-determined time.

Sync Check functionality includes the following applications: Hot Line/Hot Bus Closing; Dead Line/Hot Bus Closing; Hot Line/Dead Bus Closing; and Dead Line/Dead Bus Closing.

Sync Check Parameters include the following configurable settings: Voltage Angle; Mechanism Operating Delay; Static Angle Delay; Dead Threshold; Live Threshold; Positive Sequence Dead Threshold; Upper Voltage Limit; Lower Voltage Limit; Lower Frequency Limit; Upper Frequency Limit; and Fail to Close Timer.

Data profiler

A fully-configurable data profiler is available which allows the user to collect information by sampling data at selectable intervals. These time-stamped values can then be viewed to determine weekly load profiles, daily harmonic disturbances or hourly voltage fluctuations. The number of days of information the data profiler can provide depends upon configuration parameters.

Refer to *Service Information S280-70-4 (ProView 4.X.X) or S280-70-21 (ProView 5.X.X) Form 6 Microprocessor-Based Recloser Control Programming Guide* for additional Idea Workbench information.

Form 6 microprocessor-based pole-mount recloser control

Manual close delay

Manual Close Delay provides a delay from the time that the manual CLOSE button is pushed to the time the manual close operation is performed.

The delay is programmable from 0 to 60 seconds in 1 second increments. A programmed delay value can be overridden for immediate closing by pressing the CLOSE button a second time.

An active Manual Close Delay can be canceled by pressing the TRIP/LOCKOUT button.

The default setting has the feature disabled (0 seconds). A countdown on the front panel LCD screen indicates Manual Close Delay is active.

Communications

Communication ports

The Form 6 control has two back panel communication ports and a front panel configuration data port.

The front panel configuration data port is described in the **Operating panel** section of this manual.

There is one standard 9-pin RS-232 and one optional communication port (RS-485, serial fiber, Ethernet wire or fiber or both) on the back operator panel, as well as a standard IRIG-B port for user time-syncing. See **Figure 8**.

Communication protocols

Four communication protocols are available for the Form 6 recloser control:

- Modbus
- DNP3
- 2179
- IEC870-5-101

One communication protocol can be selected for either the back panel RS-232 or the optional communication port.

All four protocols are selected and configured by the user with the ProView Communications Workbench application software.

Ethernet communications

- ProView over TCP/IP
- DNP3 over TCP/IP

Ethernet connection allows for network application of the Form 6 pole-mount control for both DNP3 and ProView protocols. In addition, the front panel data port can simultaneously communicate ProView to the PC.

Ethernet configuration is accomplished via ProView interface software. Refer to *Service Information S280-70-4 (ProView 4.X.X) or S280-70-21 (ProView 5.X.X) Form 6 Programming Guide, Section 4: Schemes, Communicating with the Form 6 Control*, for Ethernet Configuration information.

When a communication protocol is selected for the optional communication boards (serial fiber or the RS-485 serial port), the RS-232 serial port is defaulted to ProView interface software protocol.

DNP3 is factory-defaulted to the RS-232 port.

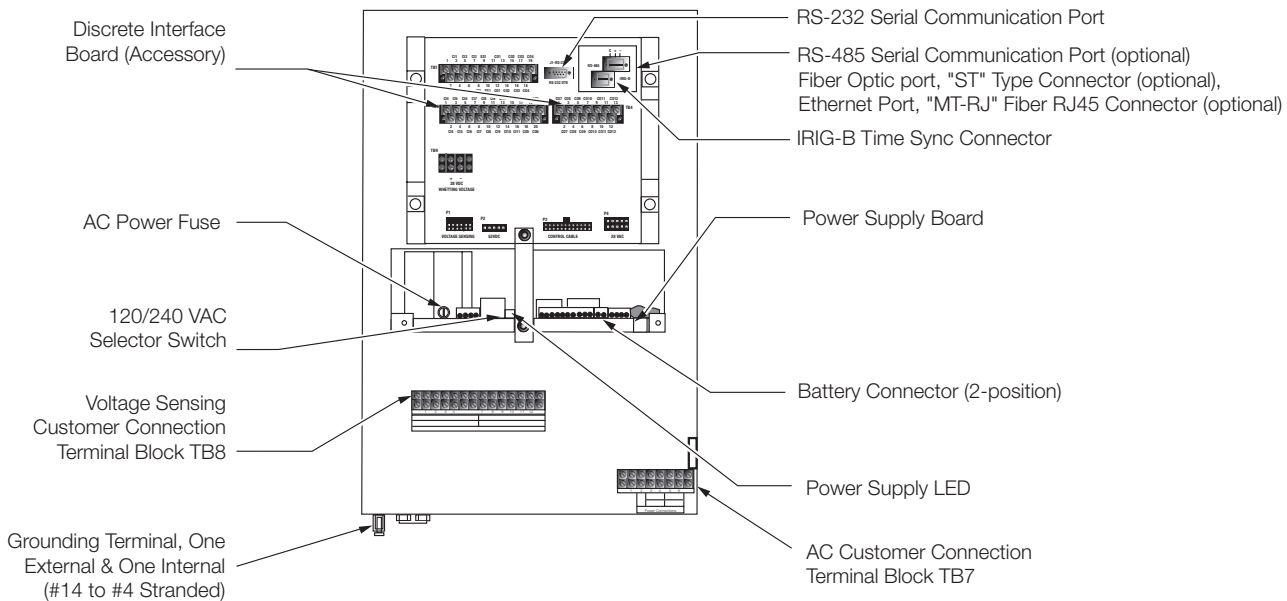

Figure 8. Form 6 pole-mount recloser control back panel terminal block and communication port identification

When a communication protocol is selected for the RS-232 serial port, the optional RS-485 or serial fiber optic board is not active.

The RS-485 or fiber optic serial ports do not support ProView interface software protocol.

The user can simultaneously communicate to the Form 6 control using both the front panel data port and the appropriate back panel serial communication port (provided the back panel RS-232 port or the Ethernet optional communications board is not configured to be ProView protocol).

Control information

Control information includes firmware identification by catalog number and name, date code, and ProView release number. Control information is available through the Settings menu on the front panel (Figure 3).

Control back panel

The control back panel is easily accessible through the back door of the control cabinet (Figure 1) with readily identifiable serial ports and connections (Figure 8).

Installation procedure

Initial programming prior to installation

⚠ CAUTION

Equipment misoperation. Do not connect this control to an energized recloser until all control settings have been properly programmed and verified. Refer to the programming information for this control. Failure to comply can result in control and recloser misoperation, equipment damage, and personal injury.

G110.3

IMPORTANT

Equipment misoperation. Check minimum trip values prior to changing an alternate profile. Failure to do so may cause misoperation of the recloser under load conditions.

T280.1

IMPORTANT

Program all protection profiles. Unused alternate profiles should be programmed with the same settings as one of the applicable profiles. Default settings on unused alternate profiles can cause unnecessary outages if they are below normal system requirements.

The control must be programmed with all necessary operating settings, all alternate profiles, and parameters prior to operation with an energized recloser.

Note: Initial programming of the control is the responsibility of a qualified technician or engineer familiar with control functions and programming parameters required for the specific recloser installation.

The control must be programmed with the Form 6 ProView

interface software. Refer to *Service Information S280-70-4 (ProView 4.X.X) or S280-70-21 (ProView 5.X.X) Form 6 Microprocessor-Based Recloser Control Programming Guide* for additional information.

Note: The *Pole-mounted Control* checkbox in the ProView System Configuration screen must be selected for all Form 6 pole-mount controls. This includes both pole and substation applications.

Control/recloser compatibility

The Form 6 pole-mount recloser control is adaptable to the following Eaton Cooper Power series reclosers:

WE*, WVE27, WVE38X, VWE, VWVE27, VWVE38X, RVE, VSA12, VSA16, VSA20, VSA12B, VSA20A, VS012, VS016, NOVA15**, NOVA27** and NOVA38**.

*This control is not compatible with Form 1 Type WE reclosers below s/n 300 and RE reclosers below s/n 400.

Control-powered NOVA reclosers that are manufactured after September 2004 require a Voltage Trip/Close (VTC) interface for tripping and closing. This VTC requirement applies to three-phase control-powered NOVA reclosers with a Type A or a Type D mechanism and Form 5, Form 5 LS/UDP, Form 6, and Form 6 LS controls with the control-powered interface. These reclosers and controls are equipped with 19-pin control cable receptacles. Refer to **Recloser VTC interface and **Control VTC interface** sections of this manual for additional information.

Reclosers manufactured prior to June 1989 are equipped with Type A bushing current transformers. These reclosers were designed for use with Form 2, Form 3, and Form 3A controls. Because the Form 6 recloser control is designed for use with reclosers equipped with Type B current-sensing Transformers, reclosers retrofitted with Form 6 recloser controls should be retrofitted with Type B current transformers. All reclosers manufactured since 1989 are equipped with Type B (1000:1, 1000/500:1, or 2000:1) sensing CTs.

Reclosers equipped with Type B sensing CTs are compatible with all Eaton Cooper Power series recloser controls (Form 2, Form 3, Form 3A, Form 4A, Form 4C, FXA, FXB Form 5, Form 5 LS/UDP, and Form 6 recloser controls), and are identified with the following label prominently displayed on the recloser sleet hood or the front of the operator cabinet:

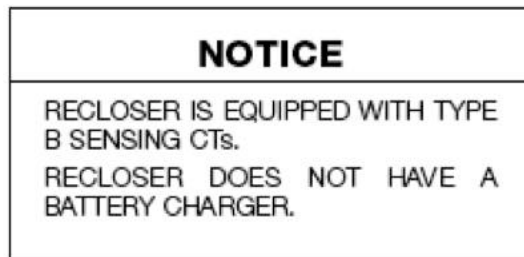

The Form 6 recloser control can be used with the old-style Type A CTs; however, the event recorder and duty cycle monitor will have limited accuracy for currents above 5000 Amps.

Retrofit kits with the new Type B sensing CTs are

Form 6 microprocessor-based pole-mount recloser control

available to upgrade existing families of reclosers for operation with Form 6 recloser controls. For additional information, contact your Eaton representative.

For identification, **Table 1** lists the serial number breaks between old-style Type A and the new-style Type B sensing CTs. Below this serial number, the recloser is equipped with the Type A CTs.

Note: For reclosers shipped prior to June 1989 and not listed below, please contact your Eaton representative with the recloser type and serial number for verification of type A or B bushing current transformers.

Table 1. Serial number break for reclosers with Type A sensing CTs

Recloser	Below serial number
RXE	5831
RVE	5894
WE	11199
WVE	3695
VVE	7199
VWVE27	7208
VWVE38	1204

All VSA reclosers are equipped with Type A Sensing CTs.

All VSML reclosers are equipped with Type A Sensing CTs.

All VSA12, VSA12B, VSA16, VSA20, VSA20A, and VSA20B reclosers are equipped with Type B Sensing CTs.

All VWVE38X and WVE38X reclosers are equipped with Type B Sensing CTs.

Duty cycle monitor

The Duty Cycle Monitor provides the following duty cycle information:

- Measures and records duty for each individual phase in non-volatile memory.
- The recloser duty is measured and stored on the basis of *Current^{t1.5} x Number of Operations for Each Phase* (ANSI C37.61).
- Readout is based on a percentage of total duty cycle for each phase.
- Duty record can be adjusted or reset if recloser is changed-out, serviced, etc.

Using **Table 2**, select the appropriate recloser interrupting duty cycle factor and enter that value via the ProView interface software.

Mounting the control

WARNING

This equipment is not intended to protect human life. Follow all locally approved procedures and safety practices when installing or operating this equipment. Failure to comply may result in death, severe personal injury, and equipment damage.

G102.1

WARNING

Falling equipment. Use the lifting lugs provided and follow all locally approved safety practices when lifting and mounting the equipment. Lift the unit smoothly and do not allow the unit to shift. Improper lifting can result in severe personal injury, death, and/or equipment damage.

G106.3

Mount the Form 6 pole-mount recloser control in a convenient, accessible location. Mounting dimensions are provided in **Figure 9**.

Note: Unless otherwise specified, dimensions shown in mm (inches).

A hole and keyway in the control mounting bracket accommodates a 15.9 mm (5/8") bolt.

Locking the control

The handles on the Form 6 control cabinet are able to accept a padlock to prevent unauthorized access. For cabinets with the quarter-turn latch, the top handle has two locking holes provided depending on the diameter of the lock shackle being used. Refer to **Figure 9**.

- Use the smaller hole for shackle diameters of .177-295"
- Use the larger hole for shackle diameters of .295-.394"

Note: DO NOT use a smaller shackle (.177-.295) in the larger diameter hole as it will NOT LOCK the cabinet.

Table 2. Duty cycle factor

Recloser Type	Interrupting rating (rms sym amps)	100% duty cycle factor*
RXE, RVE	6,000	97
WE	12,000 @ 4.8 kV	257
WE	10,000 @ 14.4 kV	196
VVE		
VWVE27	12,000	1045
VWVE38X		
WVE27	8,000	140
WVE38X	8,000	140
VSA12	12,000	1045
VSA16	16,000	1608
VSA20		
VSA20A	20,000	2248
VSA20B		
VS012	12,000	1045
VS016	16,000	1608
Auxiliary-Powered NOVA	12,500	1111
Control-Powered NOVA	12,500	1111

*Duty Cycle Factor is Value x 10⁵.

Form 6 microprocessor-based pole-mount recloser control

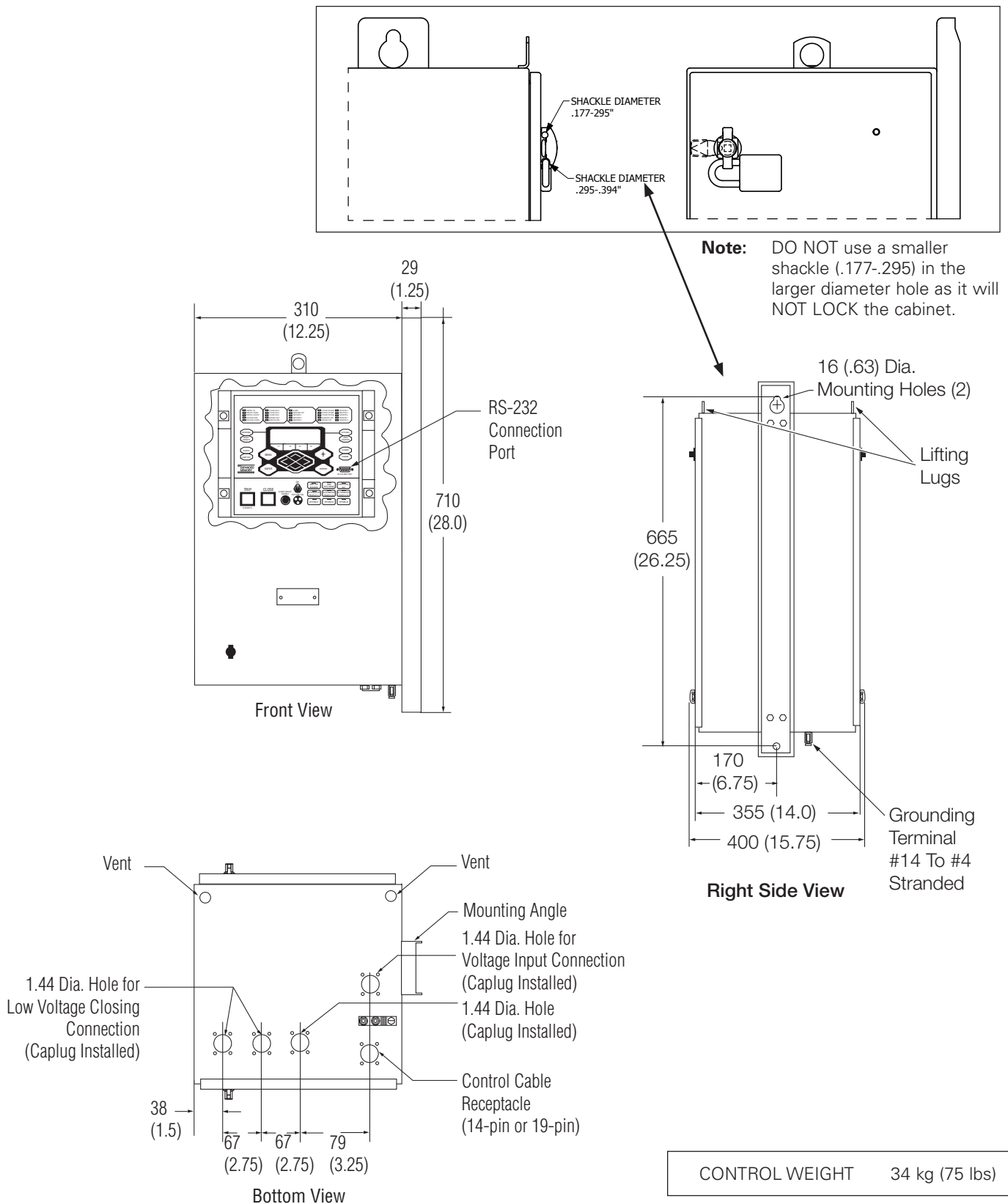

Figure 9. Form 6 pole-mount recloser control weight, dimensions, and pad-lock shackle diameters

Form 6 microprocessor-based pole-mount recloser control

Control cable

WARNING

Hazardous voltage. Recloser and control must be solidly grounded. Follow all approved procedures and safety practices when grounding this equipment. Improper grounding can result in contact with high voltage, which will cause death or severe personal injury. G115.1

The control cable is fabricated with connectors which mate with the female receptacle of the recloser on one end, and the male receptacle of the control or junction box on the other end.

Note: The control cable must be supported along its length to prevent repeated movement due to wind or other outside forces which can damage the cable.

IMPORTANT

All external inputs to the Form 6 recloser control must be routed within 8 inches of their corresponding ground. During a surge, a potential of approximately 1.5 kV per foot can develop in the conductors. Differences between conductor and ground path lengths can add additional stress to the control components in the event of a power surge.

Limits on control cable lengths are determined by the recloser type and the distance between the control and recloser: See **Table 3** for available Form 6 recloser control cable lengths for Eaton Cooper Power series reclosers.

Table 3. Available form 6 control cable lengths for Eaton Cooper Power series reclosers

Recloser type	Gauge	Length (meters)	Length (feet)
WE, WVE27, WVE38X, VWE, VVWE27, VVWE38X;	18	24.1 (maximum)	79 (maximum)
Auxiliary-Powered NOVA15, NOVA27, and NOVA38	16	24.4 to 38	80 to 125
VSA12, VSA12B, VSA16, VSA20, VSA20A, VSO12, VSO16	14	38.4 to 61	126 to 200
	18	3.4 to 6	11 to 20
	16	6.4 to 10.7	21 to 35
	14	11 to 15.25	36 to 50
Control-Powered NOVA15,NOVA27, and NOVA38	16	3.4 to 38	11 to 125

Grounding the control

WARNING

Hazardous voltage. Recloser and control must be solidly grounded. Follow all locally approved procedures and safety practices when grounding this equipment. Improper grounding can result in contact with high voltage, which will cause death or severe personal injury. G115.1

The control cabinet must be grounded. A grounding connector on the underside of the cabinet will accommodate No. 14 solid through No. 4 stranded conductors.

Suggested methods for grounding the control and recloser are shown in **Figure 10** and **Figure 11**.

Figure 10 illustrates grounding methods for 4-wire multi-grounded systems with local supply voltage transformer.

Figure 11 illustrates grounding methods for 4-wire multi-grounded systems with remote supply voltage transformer.

For effective surge protection, all control and power conductors for the Form 6 control must be routed parallel to a corresponding ground path. For example, the AC power supply for the control should be parallel to and equal in length to the transformer ground path. The control cable should be parallel to and routed close to the recloser ground path.

Grounding with a local supply voltage transformer; 4-wire multi-grounded

Installation of a Form 6 pole-mount recloser control with a local supply voltage transformer must include the following:

- Protection of the recloser bushings and the supplying transformer with lightning arresters.
- Grounding of the recloser head and tank.
- Grounding of the transformer tank.
- Grounding of the control cabinet.
- Grounding of the SCADA equipment.

IMPORTANT

All external inputs to the Form 6 recloser control must be routed within 8 inches of their corresponding ground. During a surge, a potential of approximately 1.5 kV per foot can develop in the conductors. Differences between conductor and ground path lengths can add additional stress to the control components in the event of a power surge.

4-wire multi-grounded systems

IMPORTANT

In pole-mounted applications, a ground connection must be made between the recloser, transformer, recloser control, and SCADA equipment for proper protection of the equipment. The pole ground must be sized per local utility practices to minimize the impedance between the recloser and the control.

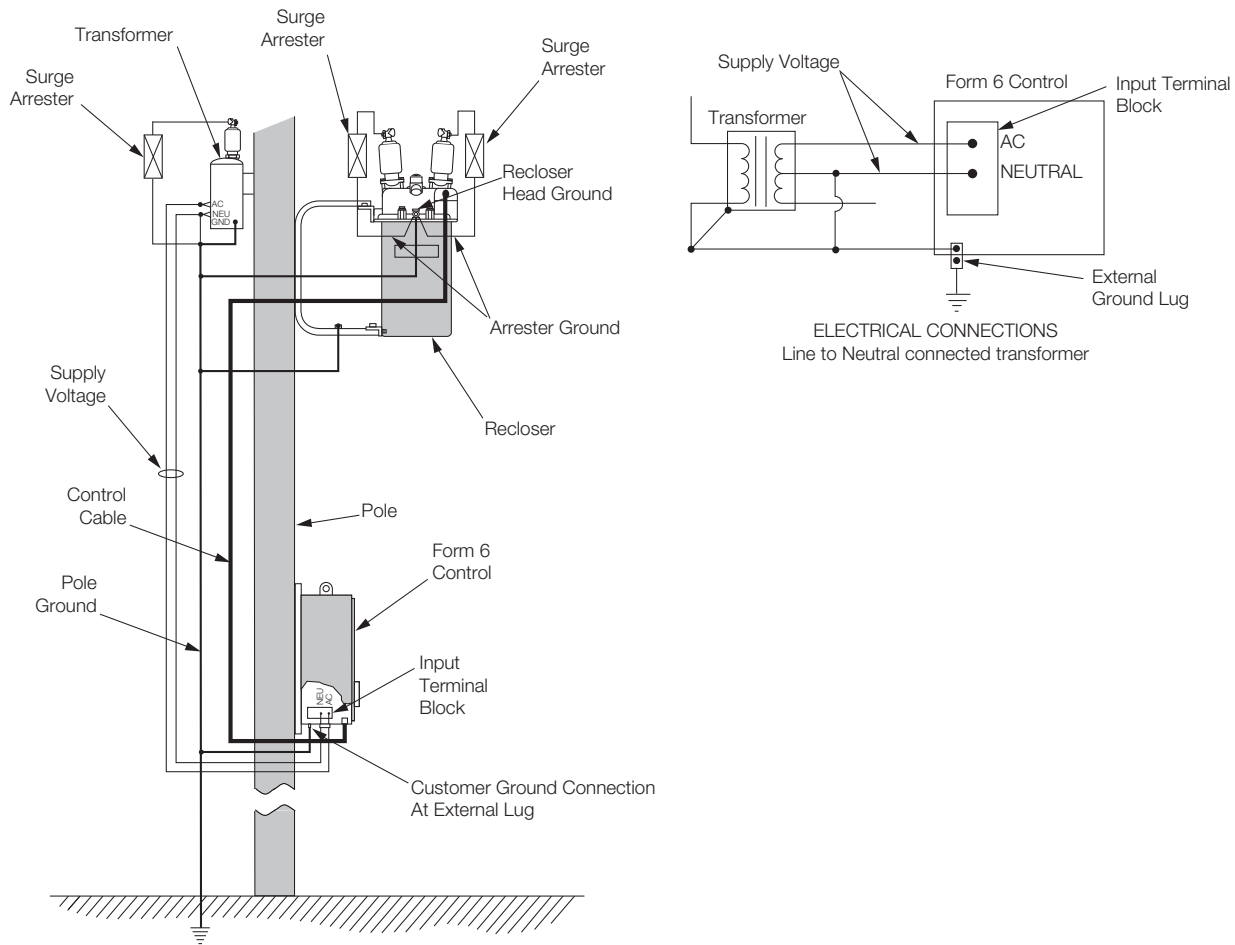

Figure 10. Recommended grounding method for the Form 6 pole-mount recloser control installed on 4-wire multi-grounded, with local supply voltage transformer

Grounding with a remote supply voltage transformer; 4-wire multi-grounded

Installation of a Form 6 pole-mount recloser control with a remote supply voltage transformer must include the following:

- Protection of the recloser bushings and the supplying transformer with lightning arresters.
- Grounding of the recloser head and tank.
- Grounding of the transformer tank.
- Grounding of the control cabinet.
- Grounding of the SCADA equipment.

IMPORTANT

In pole-mounted applications, a ground connection must be made between the recloser, transformer, recloser control, and SCADA equipment for proper protection of the equipment. The pole ground must be sized per local utility practices to minimize the impedance between the recloser and the control.

IMPORTANT

All external inputs to the Form 6 recloser control must be routed within 8 inches of their corresponding ground. During a surge, a potential of approximately 1.5 kV per foot can develop in the conductors. Differences between conductor and ground path lengths can add additional stress to the control components in the event of a power surge.

Form 6 microprocessor-based pole-mount recloser control

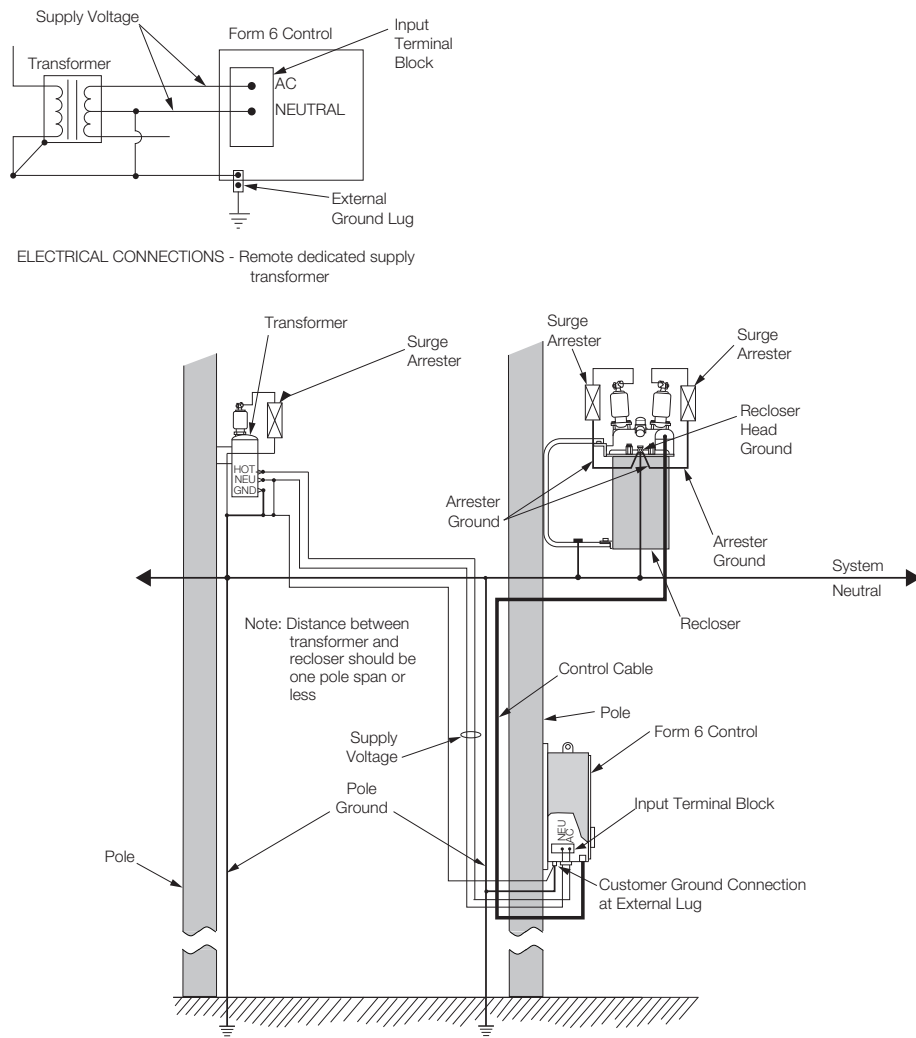

Figure 11. Recommended grounding method for the Form 6 recloser control installed on 4-wire multi-grounded with remote supply voltage transformer

Customer connections for AC power

⚠ DANGER

Hazardous voltage. Do not connect potential transformer low-voltage secondaries to the control through cables or other wiring until the unit is installed in the field. Transformer high-voltage primary windings will become live when 120/240 VAC is applied to the control from an alternate source if the transformer secondary is connected. Failure to comply may result in severe personal injury or death.

T371.2

⚠ WARNING

Hazardous voltage. Before applying power to the control, confirm that male pins of the input power receptacle are electrically insulated to prevent unintentional contact with 120/240 VAC voltage. Failure to do so may result in severe personal injury or death.

T372.1

⚠ CAUTION

Equipment damage. Do not drill connection holes into the top of the cabinet. Connection holes in the top of the cabinet will allow moisture to seep into the control and damage the components or cause control misoperation. Failure to comply will void the control's factory warranty.

T249.0

Input power to the Form 6 pole-mount recloser control is connected to terminal block TB7 for single-phase power or TB8 for three-phase power.

See **Figure 14**, **Figure 16**, and **Figure 18**. For single-phase incoming voltage supply for 120 VAC or 240 VAC, connect to TB7 as shown in **Figure 14**. For three-phase incoming voltage supply, the user should supply and connect to TB8 as shown in **Figure 16**. For 240 Volt, 3-wire transformer connection refer to **Figure 18**. Refer to **Accessory** section for 120 VAC or 240 VAC low voltage closing.

Input power is required:

- To power the control
- To provide voltage and power metering
- To power the thermostatically controlled heater
- For the low voltage closing accessory
- For the convenience outlet accessory

Power supply/battery charger board

Incoming AC power is routed to the Power Supply / Battery Charger Board designed to accept either 120 VAC or 240 VAC through a selector switch located directly on the board (Figure 12). The battery charger includes a temperature-compensated design to optimally charge the control battery. The power supply / battery charger board also includes an auxiliary power supply for connection to communication equipment (radios, modems, etc.). The auxiliary power supply is rated 28 VDC, 65 Watts peak. A separate 28 VDC to 13.8 VDC power supply accessory is available for communication equipment rated for 13.8 VDC. Some additional features are as follows:

- Positive LED indicator for power supply presence.
- Selectable 120/240 VAC switch for adapting to multiple transformer connections. The selector switch is factory-set based upon each customer order.
- Self-protective fuse (5 amp, 250 VAC).
- 28 VDC whetting voltage for I/O contact inputs.

CAUTION

Equipment misoperation. Verify that the 120/240 VAC selector switch is correctly set for incoming voltage. Failure to comply may cause misoperation (unintentional operation) of the control and/or equipment damage resulting in personal injury.

T278.0

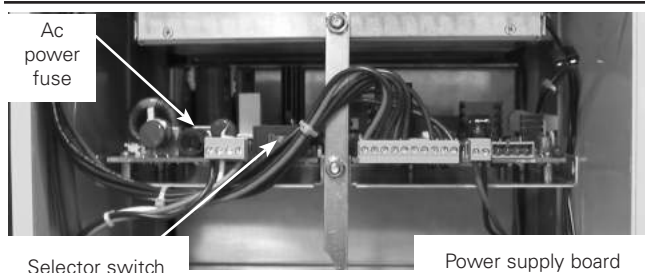

Figure 12. Power supply/battery charger board

IMPORTANT

Prior to energizing the control, the selector switch must be set as follows:

- For 120 VAC incoming power, the selector switch must be set to the 115V position.
- For 240 VAC incoming power, the selector switch must be set to the 230V position.

Terminal blocks

Two terminal blocks are used for connection to the Form 6 recloser control. Both terminal blocks are fit for a #6 screw which can allow a maximum ring size for a #10 AWG for metering.

Terminal Block TB7 provides power to the Form 6 recloser control and is directly connected to the power supply circuit board. Terminal Block TB8 is used to connect sensing transformer voltage. The wiring of the transformers should follow the application illustrations per Figure 15 through Figure 18.

Default factory wiring includes connection of two wires from Power Supply Terminal Block TB7 to the Metering Terminal Block TB8. See Figure 13.

Figure 17 shows customer connections for TB8, 120 VAC Delta Connection.

The wiring from TB7-3 to TB8-3 and from TB7-5 to TB8-4 connects the metering B phase to the control. If the incoming power supply voltage is different, the B phase power supply input must be moved to the appropriate location. See Figure 15.

For A phase incoming power, connect to TB8-1.

For C phase incoming power, connect to TB8-5.

Note: Terminal Block positions TB7-3 and TB7-4 are factory-jumpered together.

Note: Terminal Block positions TB7-5 and TB7-6 are factory-jumpered together.

Power connections

The transformer required for power should be a minimum of 5 kVA for low-voltage AC closing reclosers and 1 kVA for high voltage AC closing reclosers and control-powered NOVA reclosers.

Form 6 microprocessor-based pole-mount recloser control

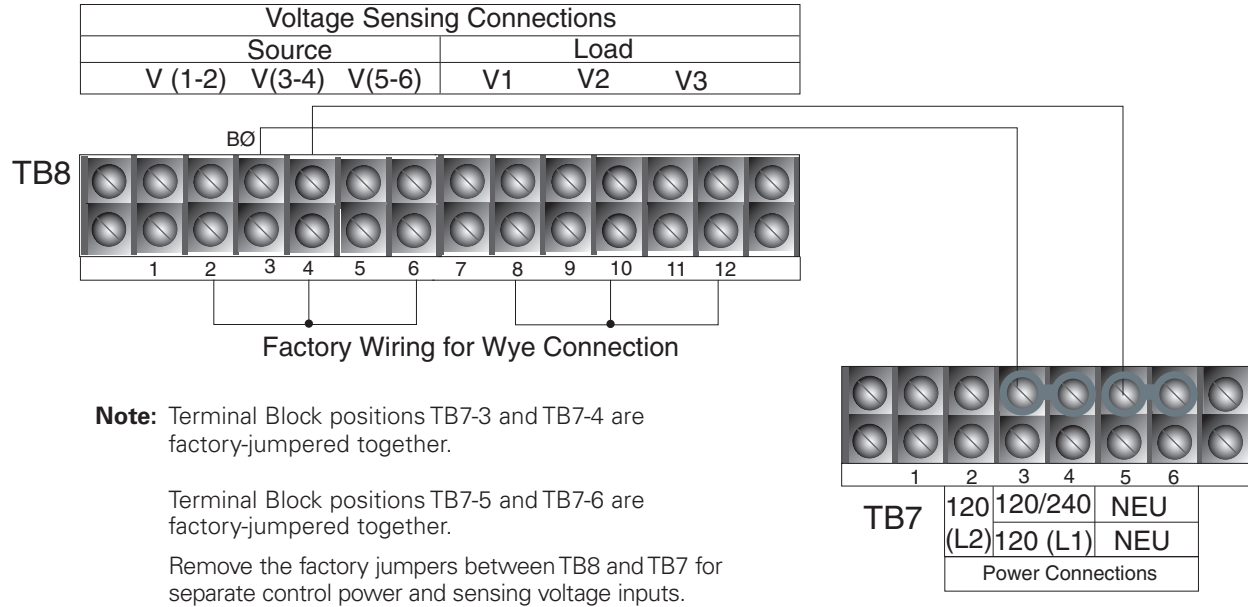

Figure 13. Default factory wiring connected to B-Phase voltage metering with B-Phase incoming supply

DANGER

Hazardous voltage. Do not connect potential transformer low-voltage secondaries to the control through cables or other wiring until the unit is installed in the field. Transformer high-voltage primary windings will become live when 120/240 VAC is applied to the control from an alternate source if the transformer secondary is connected. Failure to comply may result in severe personal injury or death.

T371.2

WARNING

Hazardous voltage. Before applying power to the control, confirm that male pins of the input power receptacle are electrically insulated to prevent unintentional contact with 120/240 VAC voltage. Failure to do so may result in severe personal injury or death.

T372.1

⚠ DANGER

Hazardous voltage. Do not connect potential transformer low-voltage secondaries to the control through cables or other wiring until the unit is installed in the field. Transformer high-voltage primary windings will become live when 120/240 VAC is applied to the control from an alternate source if the transformer secondary is connected. Failure to comply may result in severe personal injury or death.

T371.2

⚠ WARNING

Hazardous voltage. Before applying power to the control, confirm that male pins of the input power receptacle are electrically insulated to prevent unintentional contact with 120/240 VAC voltage. Failure to do so may result in severe personal injury or death.

T372.1

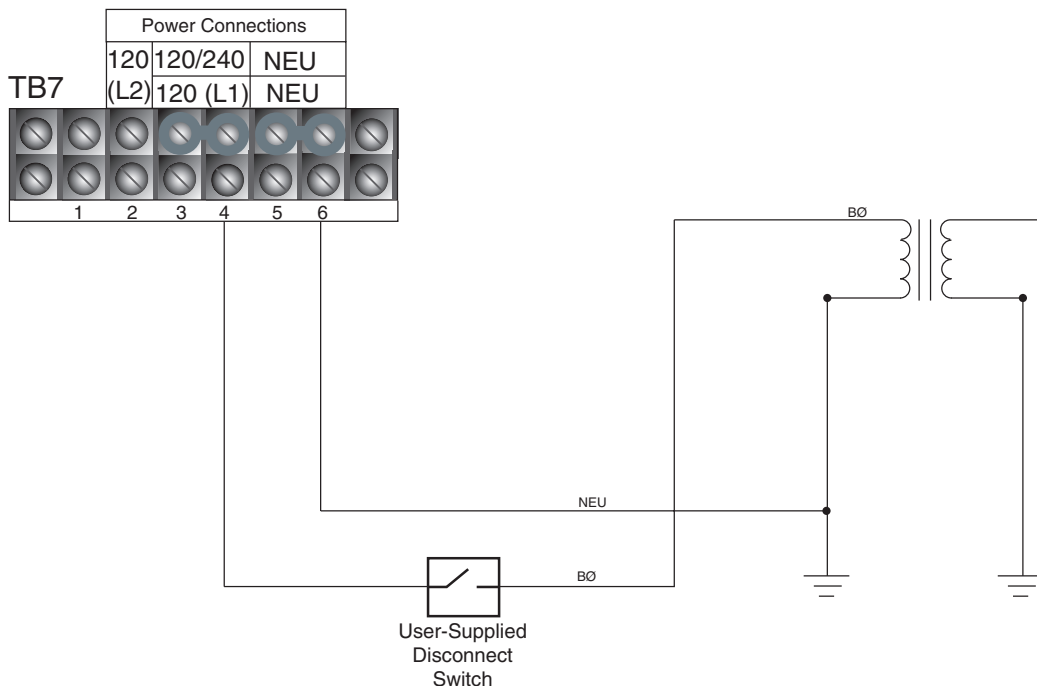

Note: Terminal Block positions TB7-3 and TB7-4 are factory-jumpered together.
Terminal Block positions TB7-5 and TB7-6 are factory-jumpered together.

Figure 14. Single-phase transformer connection, B phase input for Power and Sensing

Voltage Sensing Connections					
Source			Load		
V (1-2)	V(3-4)	V(5-6)	V1	V2	V3

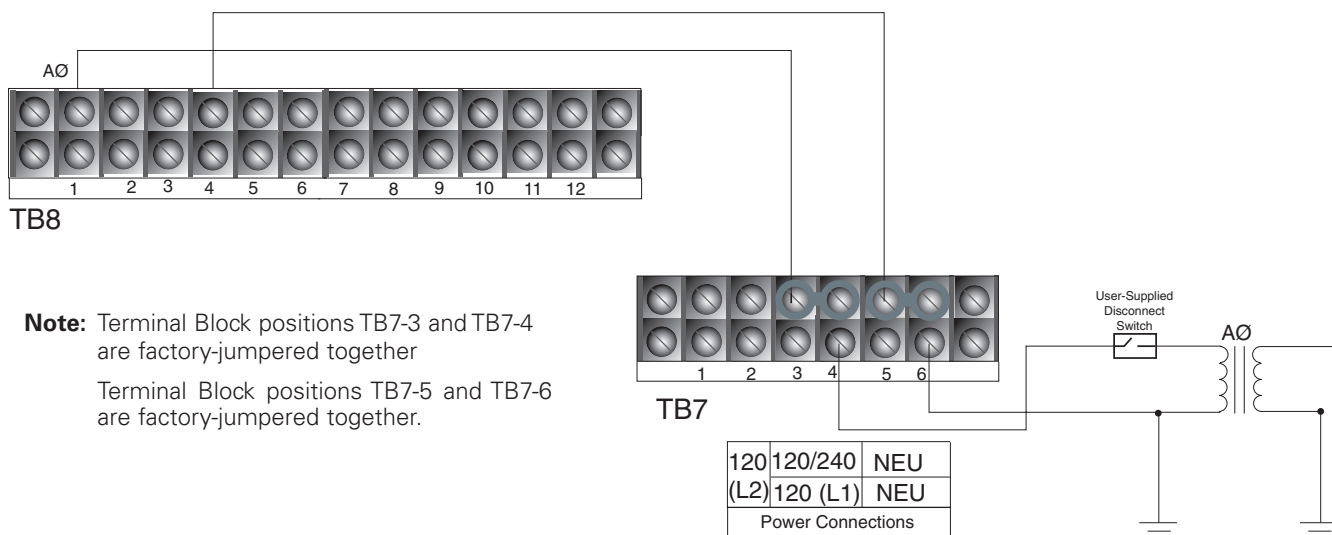

Note: Terminal Block positions TB7-3 and TB7-4 are factory-jumpered together.
Terminal Block positions TB7-5 and TB7-6 are factory-jumpered together.

Figure 15. Modified wiring connected to A-Phase voltage metering with A-Phase incoming supply

⚠ DANGER

Hazardous voltage. Do not connect potential transformer low-voltage secondaries to the control through cables or other wiring until the unit is installed in the field. Transformer high-voltage primary windings will become live when 120/240 VAC is applied to the control from an alternate source if the transformer secondary is connected. Failure to comply may result in severe personal injury or death.

T371.2

⚠ WARNING

Hazardous voltage. Before applying power to the control, confirm that male pins of the input power receptacle are electrically insulated to prevent unintentional contact with 120/240 VAC voltage. Failure to do so may result in severe personal injury or death.

T372.1

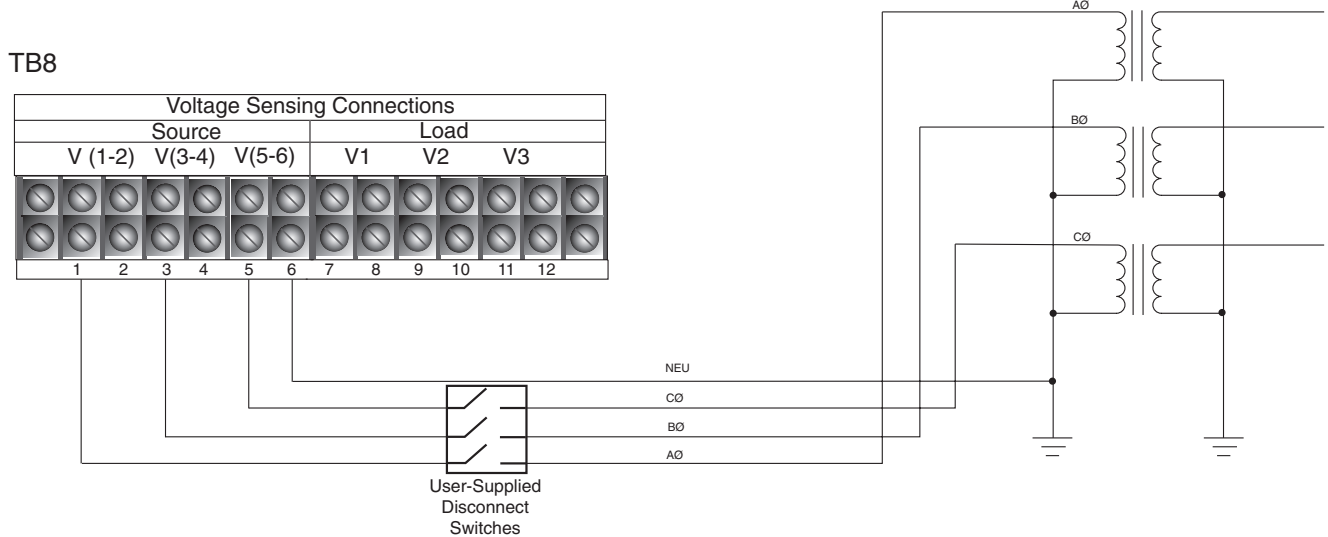
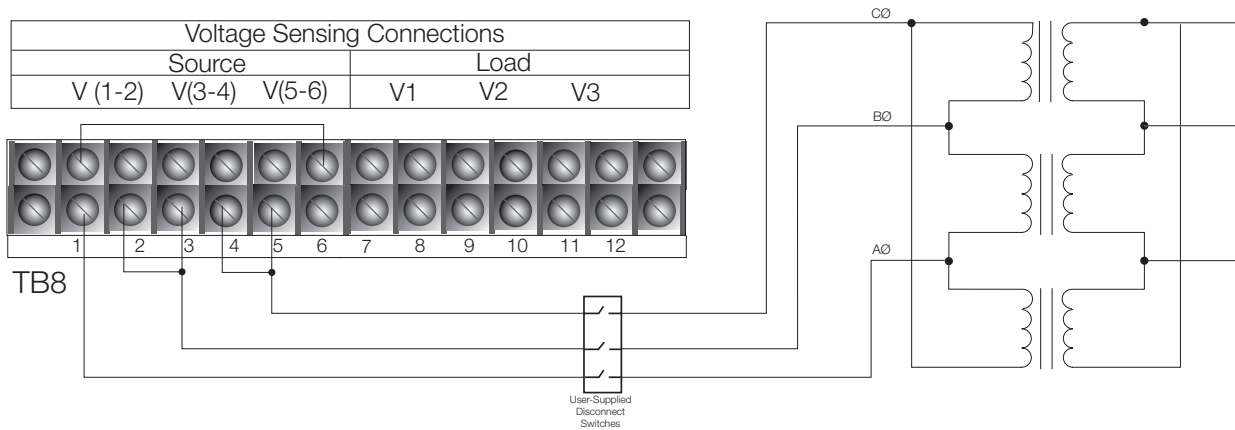

Figure 16. Three-phase transformer connection, Wye configuration only (TB8 terminal block connection)



Note: Terminal Block positions TB8-1 and TB8-6 are factory-jumpered together for Delta connection only.
 Terminal Block positions TB8-2 and TB8-3 are factory-jumpered together for Delta connection only.
 Terminal Block positions TB8-4 and TB8-5 are factory-jumpered together for Delta connection only.
 Remove factory jumpers for Wye application.

Figure 17. Customer connections to TB8, 120 VAC Delta Connection

⚠ DANGER

Hazardous voltage. Do not connect potential transformer low-voltage secondaries to the control through cables or other wiring until the unit is installed in the field. Transformer high-voltage primary windings will become live when 120/240 VAC is applied to the control from an alternate source if the transformer secondary is connected. Failure to comply may result in severe personal injury or death.

T371.2

⚠ WARNING

Hazardous voltage. Before applying power to the control, confirm that male pins of the input power receptacle are electrically insulated to prevent unintentional contact with 120/240 VAC voltage. Failure to do so may result in severe personal injury or death.

T372.1

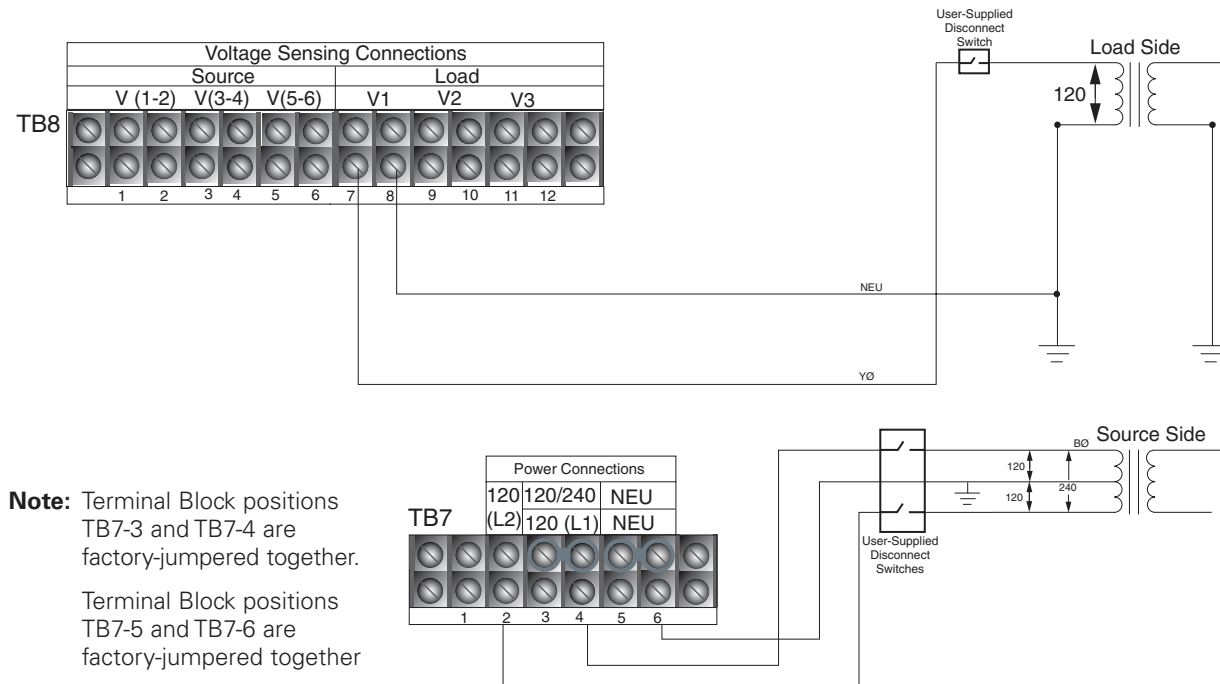

Note: Terminal Block positions TB7-3 and TB7-4 are factory-jumpered together.
Terminal Block positions TB7-5 and TB7-6 are factory-jumpered together

Figure 18. 240 Volt, 3-wire transformer connection. B phase input for Power and Sensing. *YØ for Sync Check Voltage

Standard default supervisory input control and output status contacts

Standard customer connections TB1 and accessory customer connections are TB3 and TB4. Refer to **Figure 19** and **Figure 20** and **Table 4**, **Table 5**, and **Table 6**. The Idea Workbench allows customization of all the control and status points. Refer to *Service Information S280-70-4 (ProView 4.X.X)* or *S280-70-21 (ProView 5.X.X)* *Form 6 Microprocessor-Based Recloser Control Programming Guide* for additional information.

NOTICE

External leads must be shielded and the shield must be grounded at both ends. Terminate each lead with a 320 VAC, 150 Joules metal oxide varistor (MOV), or equivalent, at the remote end. Attach MOVs between the leads and ground. Failure to properly shield and protect leads can result in equipment damage and/or unintentional operation.

IMPORTANT

Shielding and Surge Protection of Supervisory Cables

All supervisory operation and control monitor leads must be protected within shielded cables. Refer to **Figure 21**.

Form 6 microprocessor-based pole-mount recloser control

Table 4. Operating current requirements for standard and optional supervisory inputs

Input voltage	Nominal current	Minimum operating time
12 VDC – 250 VDC, 120/240 VAC	2.5 mA	5 milliseconds

Table 5. Ratings table for output status contacts CO1 through CO12 (Resistive load – pickup time 8 ms, dropout 15 ms)

Input voltage	Contact rating
120 VAC	8 A
12 VDC	8 A
24 VDC	8 A
48 VDC	1 A
125 VDC	0.4 A

Table 6. Ratings table for output status contact SS1 (resistive load – pickup time 2 ms, dropout 15 ms)

Input voltage	Contact rating
120 VAC	8 A
12 VDC	8 A
24 VDC	8 A
48 VDC	8 A
125 VDC	8 A

NOTICE

External leads must be shielded and the shield must be grounded at both ends. Terminate each lead with a 320 VAC, 150 Joules metal oxide varistor (MOV), or equivalent, at the remote end. Attach MOVs between the leads and ground. Failure to properly shield and protect leads can result in equipment damage and/or unintentional operation.

IMPORTANT

Shielding and Surge Protection of Supervisory Cables

All supervisory operation and control monitor leads must be protected within shielded cables. Refer to **Figure 21**.

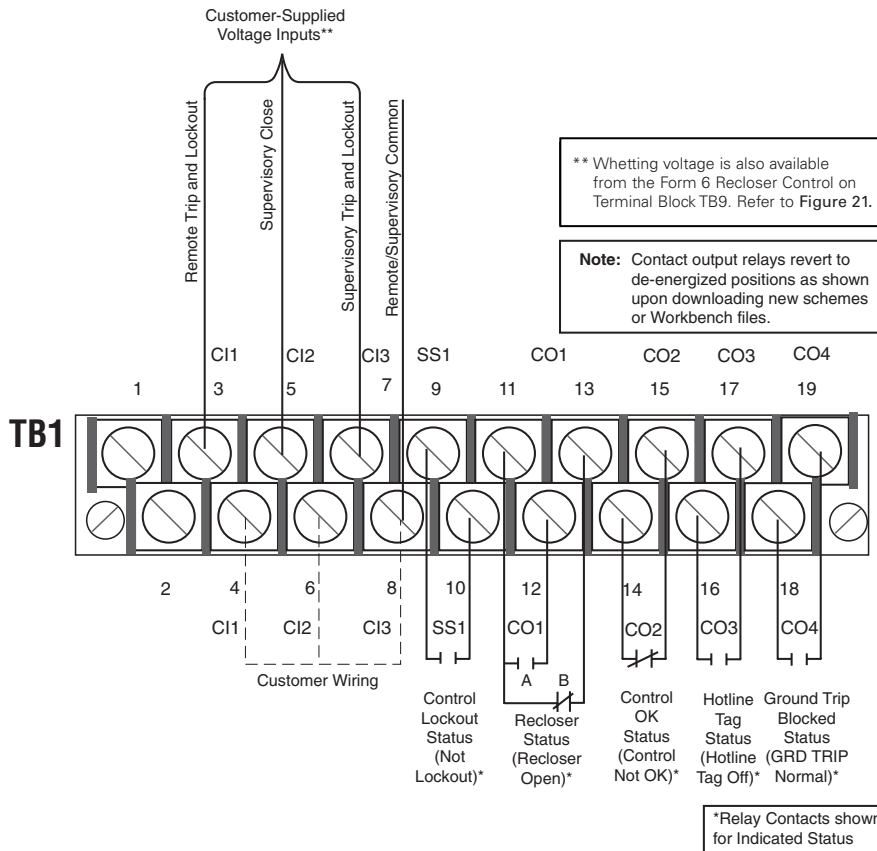

Figure 19. Form 6 pole-mount recloser control standard default supervisory input control and output status contacts

NOTICE

External leads must be shielded and the shield must be grounded at both ends. Terminate each lead with a 320 VAC, 150 Joules metal oxide varistor (MOV), or equivalent, at the remote end. Attach MOVs between the leads and ground. Failure to properly shield and protect leads can result in equipment damage and/or unintentional operation.

IMPORTANT

Shielding and Surge Protection of Supervisory Cables

All supervisory operation and control monitor leads must be protected within shielded cables. Refer to **Figure 21**.

** Whetting voltage is available from the Form 6 Recloser Control on Terminal Block TB9. Refer to Figure 21.

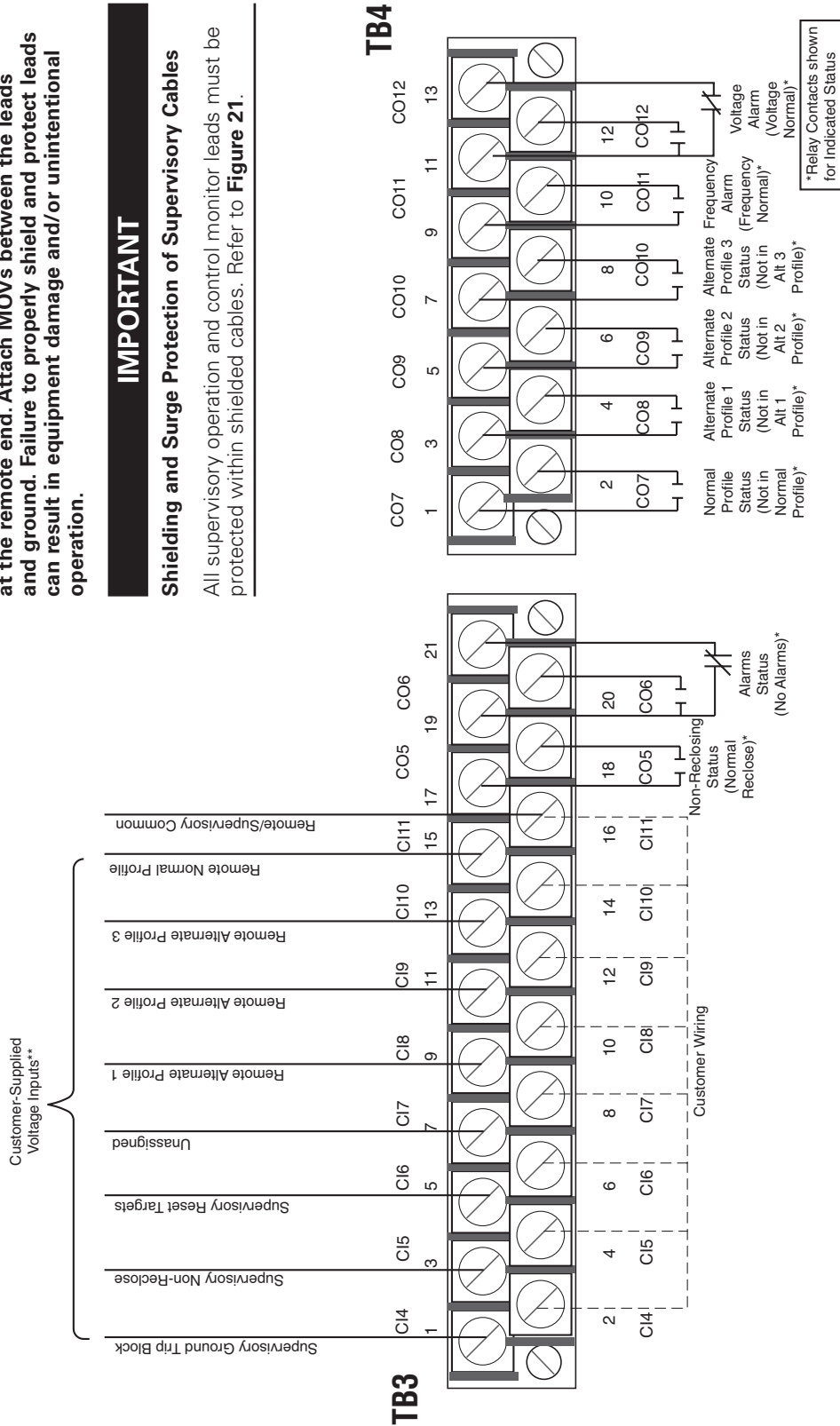

Figure 20. Form 6 pole-mount recloser control Discrete Interface Board accessory default supervisory input control and output status contacts

Form 6 microprocessor-based pole-mount recloser control

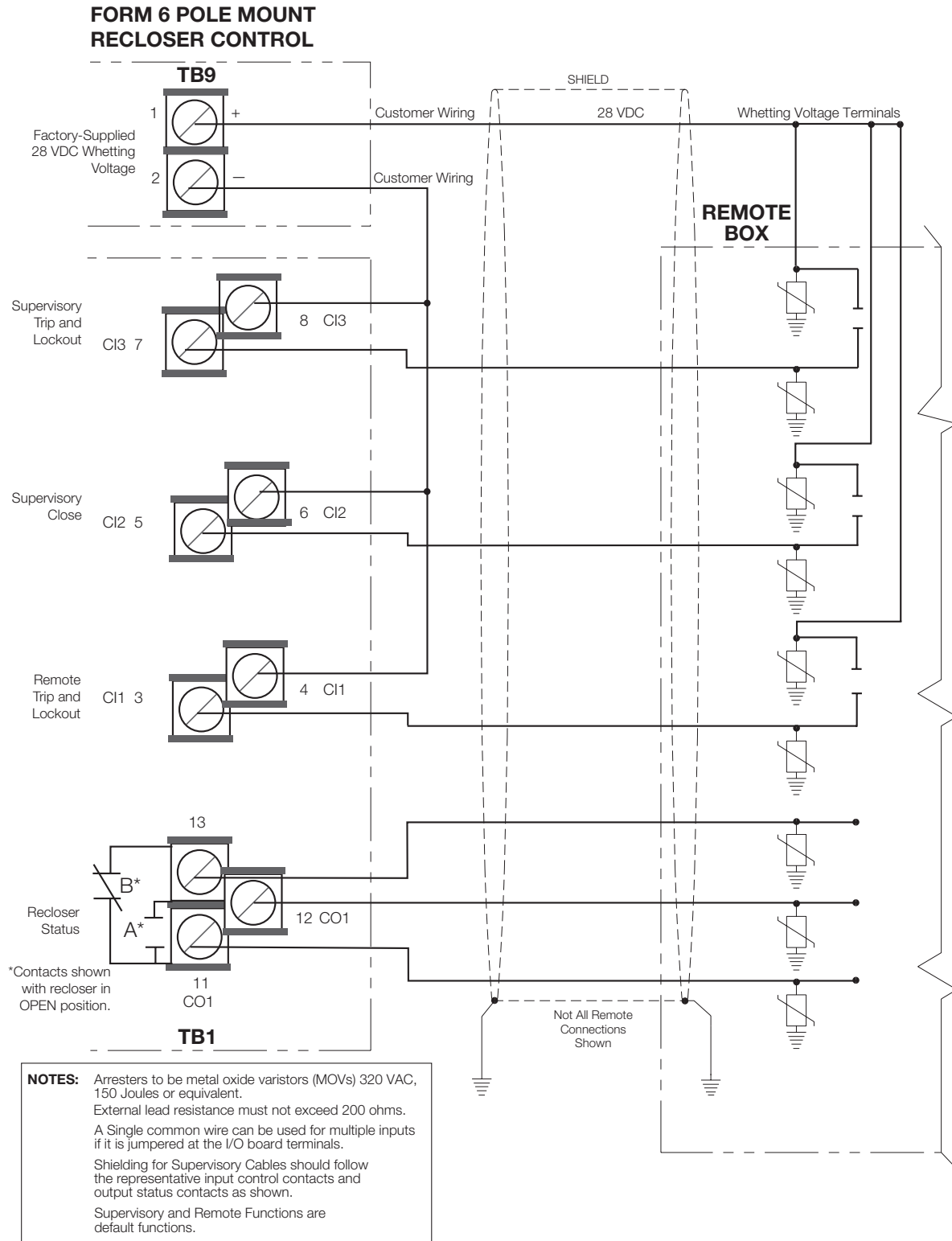

Figure 21. Shielding and surge protection for supervisory and remote cables

Rear panel RS-232 communication port pin assignments

Table 7 indicates the pin assignments for the rear panel RS-232 communication port (Figure 22). Refer to Figure 23 for pin identification. Refer to **Communication protocols** for additional information.

Refer to the **Accessories** section of this manual for additional communication options.

Table 7. Rear panel RS-232 communication port pin assignments

Pin Number	Signal Name
1 DCD	Carrier Detect
2 RXD	Receive Data
3 TXD	Transmit Data
4 DTR	Data Terminal Ready (Not Connected)
5 GND	Signal Ground
6 DSR	Data Set Ready (Not Connected)
7 RTS	Request to Send
8 CTS	Clear to Send
9 NC	Not Used
10 (Shroud)	Chassis Ground

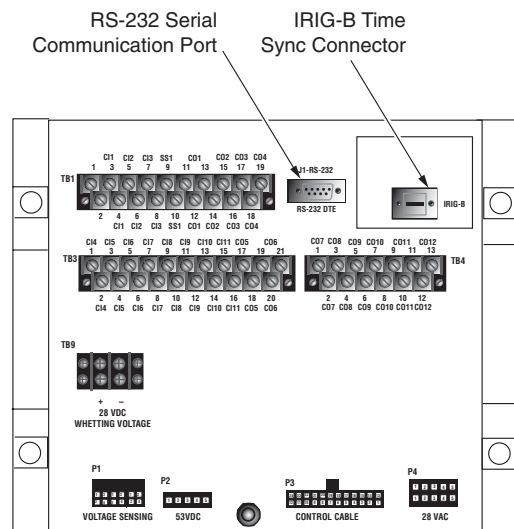

Figure 22. Form 6 pole-mount recloser control rear panel RS-232 communication ports (standard configuration)

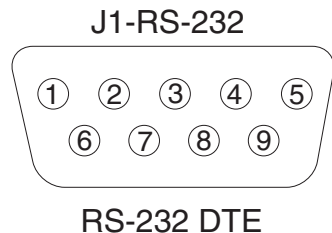

Figure 23. Rear panel RS-232 communication port pin identification

Before placing the control and the recloser into service

CAUTION

Equipment misoperation. Do not connect this control to an energized recloser until all control settings have been properly programmed and verified. Refer to the programming information for this control. Failure to comply can result in control and recloser misoperation, equipment damage, and personal injury.

G110.3

Prior to placing the control and recloser into service, the following installation procedures must be properly completed and verified:

1. Front panel label inserts changed (if applicable).

Note: Refer to **Using Removable Inserts** in this manual.

2. Control properly mounted for the installation.
3. Recloser installed according to all locally approved standards and practices.
4. AC disconnect switches installed.
5. Control and recloser properly grounded in accordance with guidelines in this manual and the applicable recloser manual.

CAUTION

Equipment misoperation. Verify that the 120/240 VAC selector switch is correctly set for incoming voltage. Failure to comply may cause misoperation (unintentional operation) of the control and/or equipment damage resulting in personal injury.

T278.0

6. Control cable properly connected and supported.
7. Verify the selector switch on the Power Supply/Battery Charger Board is set to the correct position based upon the incoming power supply:
 - For 120 VAC incoming power, the selector switch must be set to the 115V position.
 - For 240 VAC incoming power, the selector switch must be set to the 230V position.
8. Control battery connected and tested for proper operation.

Note: The battery test is blocked for 30 seconds upon power-up of the control.

Test the battery as follows:

- A. Press the MENU button on the front panel.
- B. Using the down arrow key, navigate to the BATTERY menu and press ENTER.
- C. Using the down arrow key, navigate to the TEST BATTERY menu and press ENTER.
- D. Press the F4 button to test the battery.

Note: This message will appear on the programming panel LCD display: ---TESTING---

Form 6 microprocessor-based pole-mount recloser control

The battery test results will display in the battery metering menu.

Note: With AC disconnected and the battery supplying the load, current will read -400 to -600 mA depending on accessories connected.

9. AC power connected to the control. (Control OK LED indicator is illuminated.)

Note: The control Power Save feature will turn off the backlit LCD display and all LEDs if no front panel keypad is pressed within ten minutes.

10. All control programming entered and verified by appropriate personnel.

Note: Refer to *Service Information S280-70-4 (ProView 4.X.X)* or *S280-70-21 (ProView 5.X.X) Form 6 Microprocessor-Based Recloser Control Programming Guide* for additional information.

11. Control clock set to the correct time.

Note: Refer to *Service Information S280-70-4 (ProView 4.X.X)* or *S280-70-21 (ProView 5.X.X) Form 6 Microprocessor-Based Recloser Control Programming Guide* for additional information.

12. Customer connections for remote and supervisory operation checked and completed in accordance with proper shielding and surge protection (**Figure 21**).

NOTICE

External leads must be shielded, and the shield must be grounded at both ends. Terminate each lead with a 320 VAC, 150 Joules metal oxide varistor (MOV), or equivalent, at the remote end. Attach MOVs between the leads and ground. Failure to properly shield and protect leads can result in equipment damage and/or unintentional operation.

Using removable inserts

CAUTION

Control damage. De-energize both AC and DC power prior to removing or installing any internal connections or circuit boards in the control. Failure to comply can result in damage to the control.

T241.1

CAUTION

Equipment damage. Always wear a grounding wrist strap to control static electricity before handling circuit boards. Failure to use this strap may result in circuit board damage.

T253.1

The front panel inserts can be changed, if desired.

1. De-energize both AC and DC power.
2. Use a flathead or 3/32" hex key screwdriver to unscrew the six front panel screws.
3. Pull the right side of the front panel out towards the left (**Figure 24**).

Note: Various connecting wires will keep the panel attached to the control.

Note: It is not necessary to disconnect any wires.

Removable LED status indicator panel

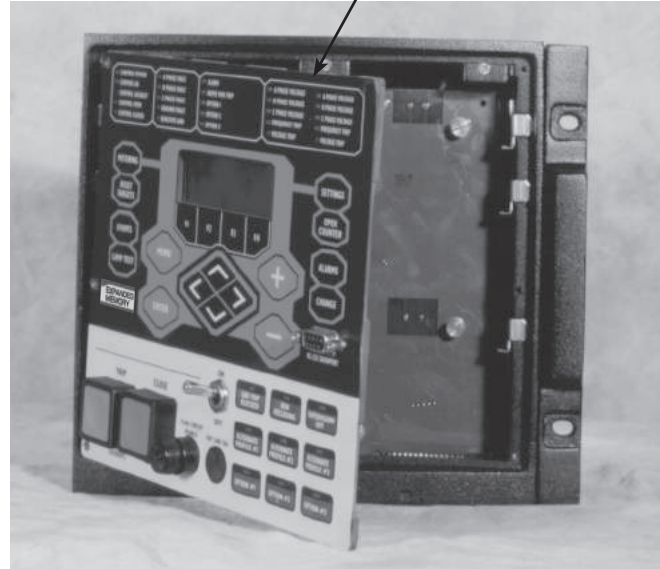

Figure 24. Open front panel. Labels are easily removed from and inserted into the top of the programming panel LED status indicator section

4. Use tweezers to gently pull out the removable insert.

Note: The insert will slide out of the right side of the operating panel (**Figure 25**).

Note: The insert will slide out of the top of the programming panel indicator section (**Figure 24**).

5. Change the existing label or slide in a new label with the name of the programmed option.

An electronic label template is included on the ProView application software CD and can be accessed through the following default address:

C:\Program Files\Cooper\ProviewXX\Form 6\Form 6 Inserts.doc

IMPORTANT

Laminate the removable inserts prior to installing. This will seal the ink/toner and avoid damage to the front panel.

6. Gently push the removable insert from right to left into the right side of the operating panel (**Figure 25**) or down into the programming panel LED indicator section (**Figure 24**).

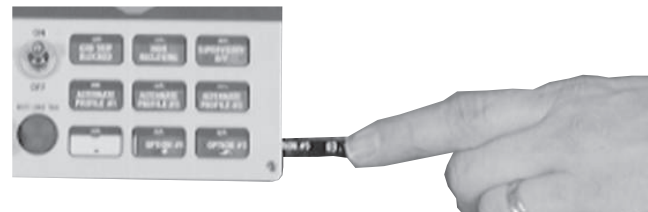

Figure 25. Labels are easily removed from and inserted into the operating panel

- Place the front cover panel back onto the control. Using a flathead screwdriver screw the screws into the control and tighten all hardware completely.

Accessories

These accessories are available. Contact your Eaton representative for additional information.

Low voltage closing

The Low Voltage Closing Accessory utilizes 120 or 240 VAC for closing power (**Figure 26** through **Figure 30**). Multiple low voltage closing accessories are available for reclosers equipped with low voltage closing. The low voltage closing accessories available for the Form 6 recloser control include the appropriate receptacles and wiring based upon the input supply voltage. **Table 8** lists the available low voltage closing input/output receptacles and cables for the Form 6 pole-mount recloser control.

Internal voltage sensing

A four-wire cable and input receptacle accessory (**Table 9**) is required for Type NOVA three-phase reclosers with the internal voltage sensing (IVS) option. Internal voltage sensors, located on the source side, indicate voltage magnitude within an accuracy 2% or better and a phase degree accuracy within 1.5 degrees (includes sensor, cable, and control). The 4-pin receptacle accessory is pre-wired to the voltage inputs on the control. Refer to *Service Instructions S280-42-1 NOVA Three-Phase Recloser Installation and Operation Instructions* for additional setting information.

Incoming power receptacles

The Incoming Power Receptacle (**Figure 31** through **Figure 33**) allows the user to conveniently plug the power cable into the control, eliminating the need for hardwiring to the control. Various options are available based upon the input power voltage, and phase sensing requirements. **Table 8** includes the available input receptacles and cables for the Form 6 pole-mount recloser control.

Cable locking sleeves

To prevent detachment of the control cable from the control cabinet by unauthorized personnel, a cable-locking sleeve (Catalog Number KME6-1772-1) is available to enclose the cable plug. The plug is passed through the sleeve and the sleeve is then fastened from inside the control cabinet. There is no access to the cable receptacle without opening the locked cabinet door and detaching the sleeve.

120 VAC GFI duplex outlet

The GFI Duplex Outlet (Catalog Number KME6-1776) is available for controls powered by 120 VAC or 240 VAC three-wire supply power. This convenience outlet is rated for 15 Amperes and is accessible through the front door in the control cabinet. The 120 VAC GFI Duplex Outlet is used for many applications such as power for the MET Tester, auxiliary measurement equipment, and supplemental lighting.

Table 8. Low voltage closing and input receptacles and cables

Description	Catalog number
120 VAC low-voltage closing 2-pin input and 2-pin output receptacles	KME6-1775-A
120 VAC low-voltage closing with 3-pin input and 2-pin output receptacles	KME6-1775-B
120 VAC low-voltage closing with inlet hole and 2-pin output receptacle	KME6-1775-C
240 VAC low-voltage closing with 2-pin input and 2-pin output receptacle	KME6-1775-D
240 VAC low-voltage closing with 3-pin input and 2-pin output receptacle	KME6-1775-E
240 VAC low voltage closing, for 2-wire with inlet hole and 2-pin output receptacle	KME6-1775-F
240 VAC low-voltage closing, for 3-wire with inlet hole and 2-pin output receptacle	KME6-1775-G
120 VAC or 240 VAC input receptacle, 2-pin	KME6-1775-H
120 VAC input receptacle, 3-pin	KME6-1775-J
240 VAC input receptacle, 3-pin	KME6-1775-K
AC Input Cable, 120 or 240 VAC, 2-wire for 2-pin input for use with KME6-1775-A, KME6-1775-D, or KME6-1775-H receptacles. Replace X with desired length. Select from 10 to 80 feet.	KMA11ME1-X
AC Input Cable, 240 VAC, 3-wire for 3-pin input for use with KME6-1775-E or KME6-1775-K receptacles. Replace X with desired length. Select from 10 to 80 feet.	KME4-67-2-X
AC Input Cable, 120 VAC, 3-wire for 3-pin input for use with KME6-1775-B and KME6-1775-J receptacles. Replace X with desired length. Select from 10 to 80 feet.	KME4-67-3-X
Low Voltage Closing Cable, 2-wire for use with KME6-1775-A, KME6-1775-B, KME6-1775-C, KME6-1775-D, KME6-1775-E, and KME6-1775-F, and KME6-1775-G low voltage closing receptacles. Replace X with desired length. Select from 10 to 80 feet.	KA13ME1-X

Table 9. Internal voltage sensing

Description	Catalog number
Internal Voltage Sensing input receptacle, 4-pin	KME6-3799-1S

Note: Internal voltage sensing receptacle is only compatible with reclosers equipped with internal voltage sensors.

Note: The internal voltage sensing cable (KA97ME) is ordered with the recloser. If a replacement cable is required, contact your Eaton representative.

⚠ DANGER

Hazardous voltage. Do not connect potential transformer low-voltage secondaries to the control through cables or other wiring until the unit is installed in the field. Transformer high-voltage primary windings will become live when 120/240 VAC is applied to the control from an alternate source if the transformer secondary is connected. Failure to comply may result in severe personal injury or death.

T371.2

⚠ WARNING

Hazardous voltage. Before applying power to the control, confirm that male pins of the input power receptacle are electrically insulated to prevent unintentional contact with 120/240 VAC voltage. Failure to do so may result in severe personal injury or death.

T372.1

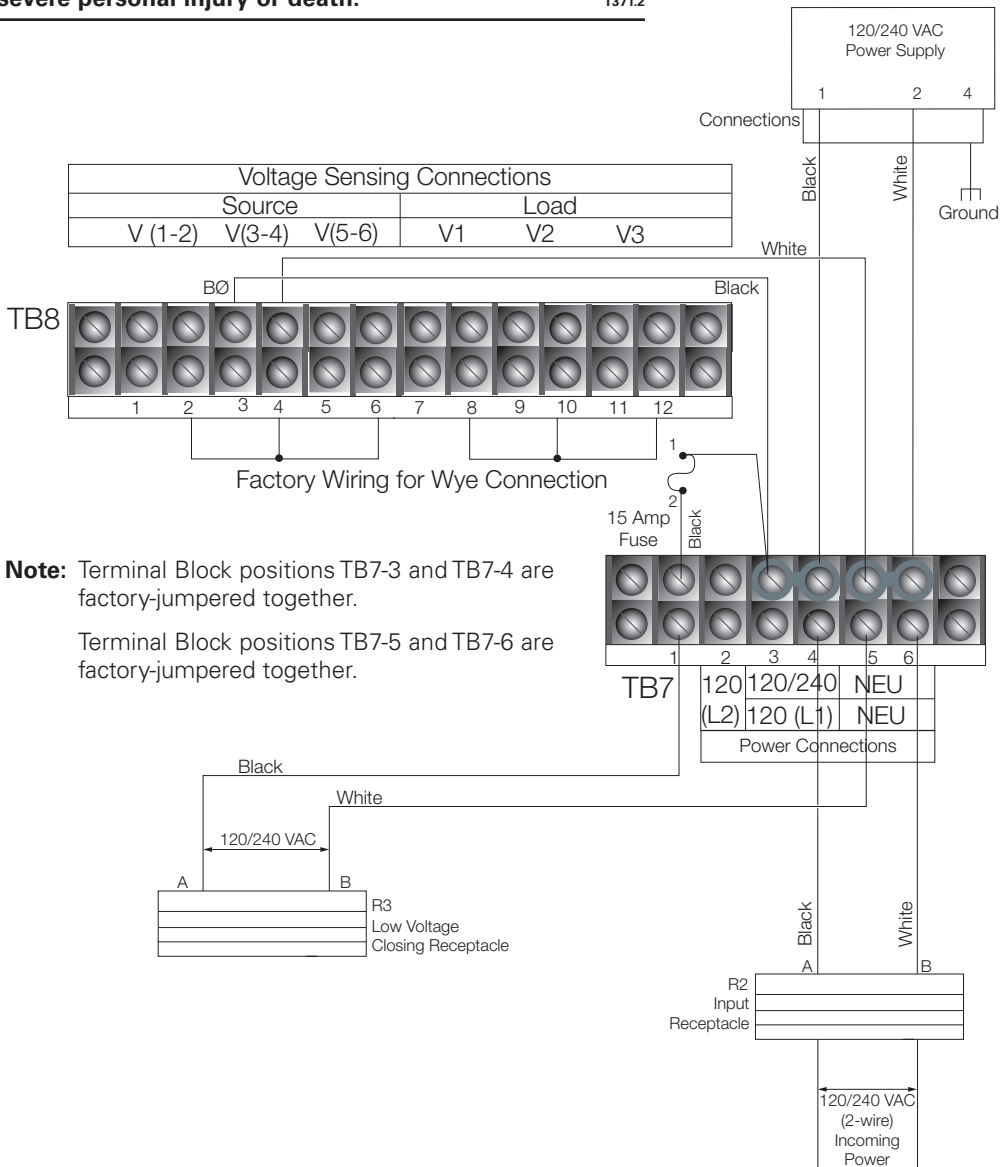

Figure 26. 120 VAC low-voltage closing 2-pin input and 2-pin output receptacles (KME6-1775-A) and 240 VAC low-voltage closing with 2-pin input and 2-pin output receptacle (KME6-1775-D)

⚠ DANGER

Hazardous voltage. Do not connect potential transformer low-voltage secondaries to the control through cables or other wiring until the unit is installed in the field. Transformer high-voltage primary windings will become live when 120/240 VAC is applied to the control from an alternate source if the transformer secondary is connected. Failure to comply may result in severe personal injury or death.

T371.2

⚠ WARNING

Hazardous voltage. Before applying power to the control, confirm that male pins of the input power receptacle are electrically insulated to prevent unintentional contact with 120/240 VAC voltage. Failure to do so may result in severe personal injury or death.

T372.1

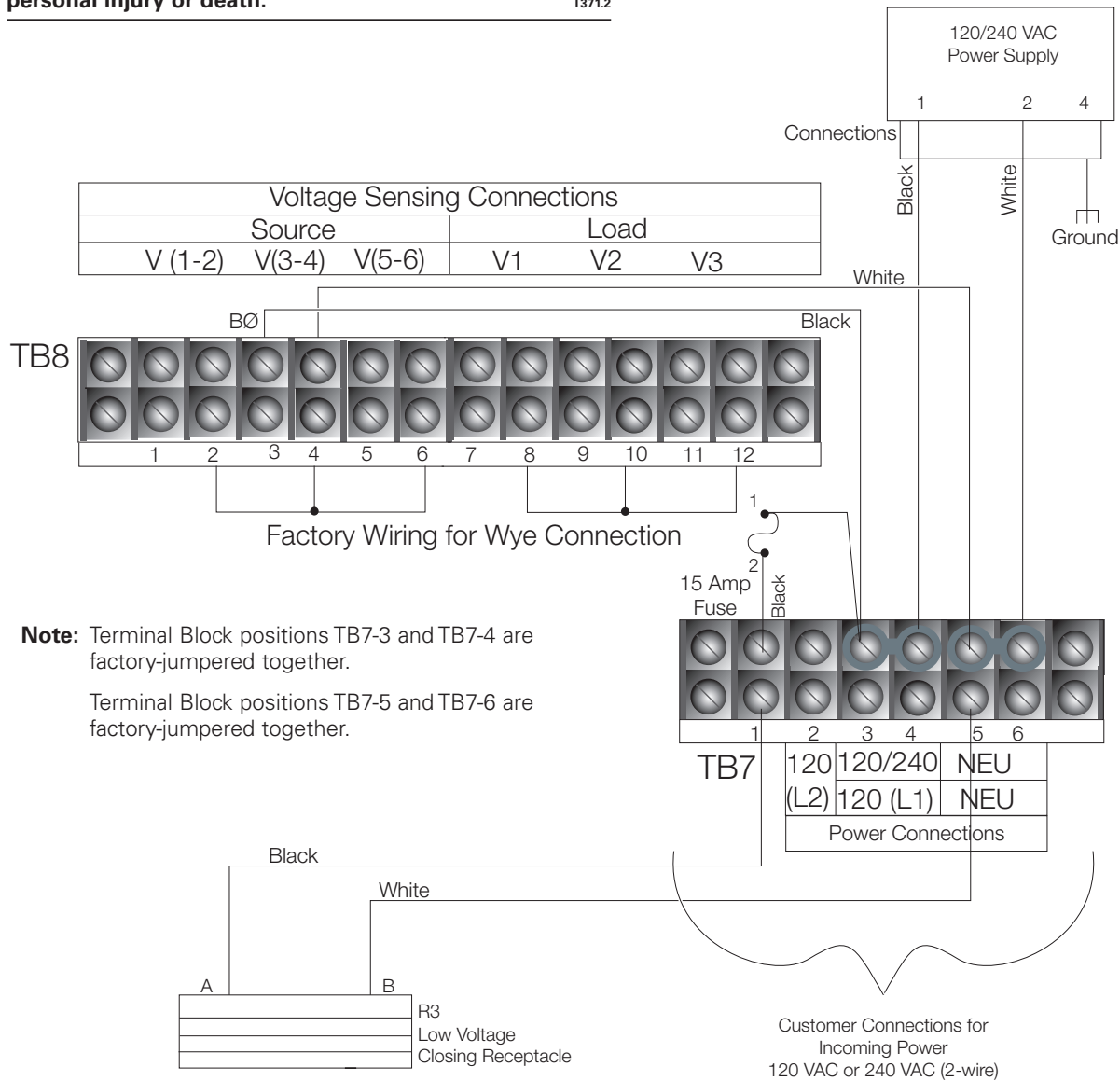

Note: Terminal Block positions TB7-3 and TB7-4 are factory-jumpered together.

Terminal Block positions TB7-5 and TB7-6 are factory-jumpered together.

Figure 28. 120 VAC low-voltage closing with inlet hole and 2-pin output receptacle (KME6-1775-C) and 240 VAC low voltage closing, for 2-wire with inlet hole and 2-pin output receptacle (KME6-1775-F)

⚠ DANGER

Hazardous voltage. Do not connect potential transformer low-voltage secondaries to the control through cables or other wiring until the unit is installed in the field. Transformer high-voltage primary windings will become live when 120/240 VAC is applied to the control from an alternate source if the transformer secondary is connected. Failure to comply may result in severe personal injury or death.

T371.2

⚠ WARNING

Hazardous voltage. Before applying power to the control, confirm that male pins of the input power receptacle are electrically insulated to prevent unintentional contact with 120/240 VAC voltage. Failure to do so may result in severe personal injury or death.

T372.1

Note: Terminal Block positions TB7-3 and TB7-4 are factory-jumpered together.
Terminal Block positions TB7-5 and TB7-6 are factory-jumpered together.

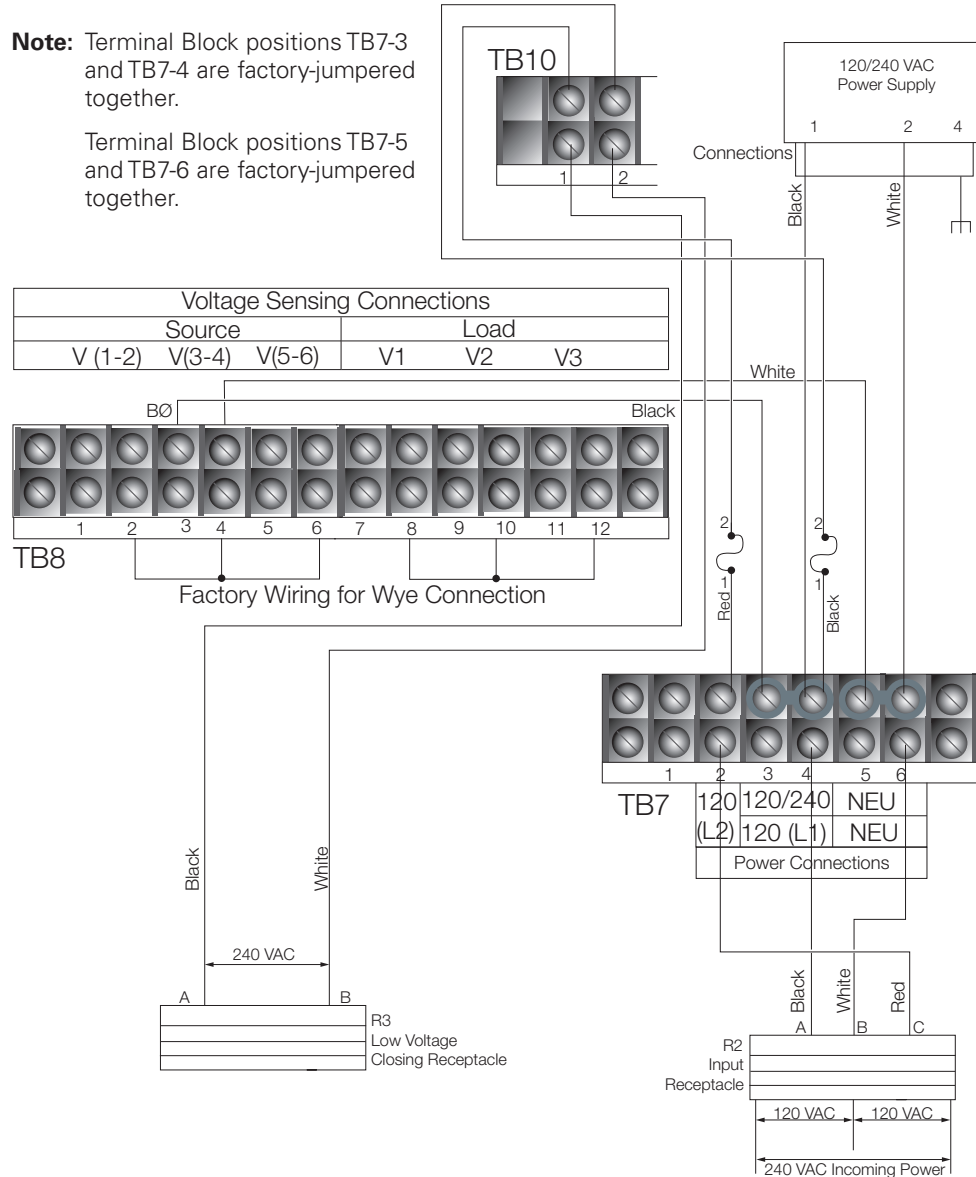

Figure 29. 240 VAC low-voltage closing with 3-pin input and 2-pin output receptacle (KME6-1775-E)

Form 6 microprocessor-based pole-mount recloser control

⚠ DANGER

Hazardous voltage. Do not connect potential transformer low-voltage secondaries to the control through cables or other wiring until the unit is installed in the field. Transformer high-voltage primary windings will become live when 120/240 VAC is applied to the control from an alternate source if the transformer secondary is connected. Failure to comply may result in severe personal injury or death.

T371.2

⚠ WARNING

Hazardous voltage. Before applying power to the control, confirm that male pins of the input power receptacle are electrically insulated to prevent unintentional contact with 120/240 VAC voltage. Failure to do so may result in severe personal injury or death.

T372.1

Note: Terminal Block positions TB7-3 and TB7-4 are factory-jumpered together.
Terminal Block positions TB7-5 and TB7-6 are factory-jumpered together.

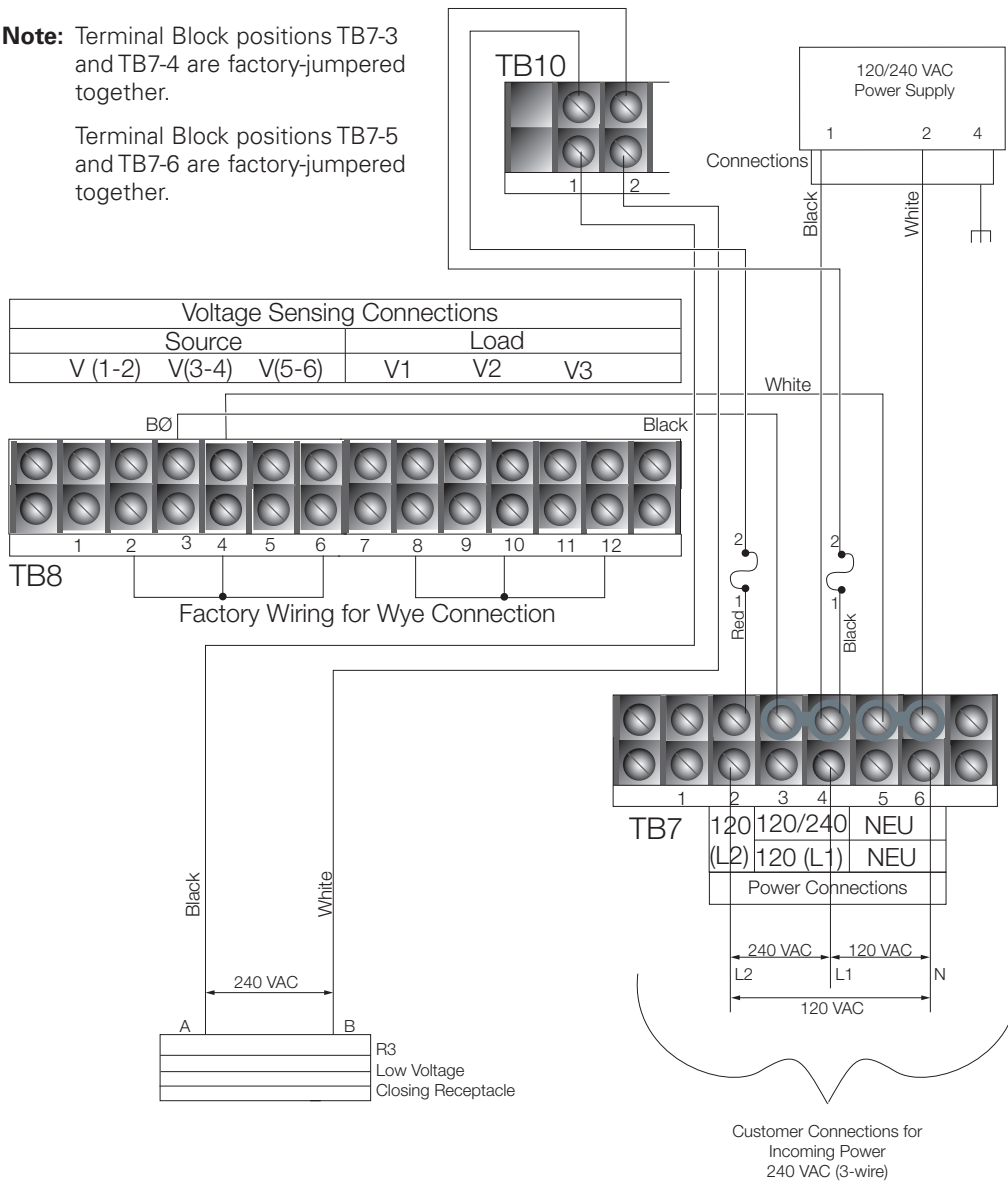

Figure 30. 240 VAC low-voltage closing, for 3-wire with inlet hole and 2-pin output receptacle (KME6-1775-G)

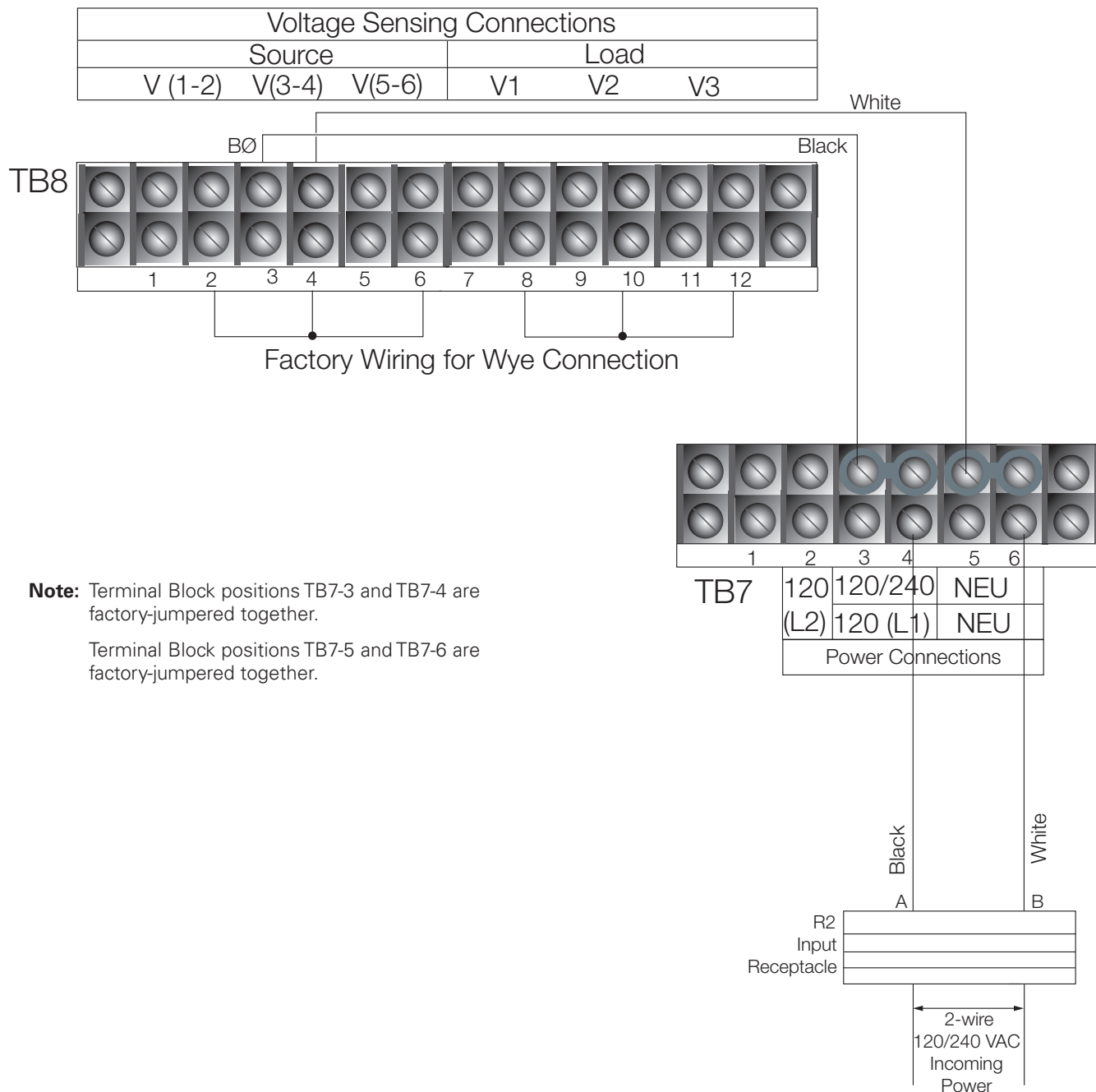

Figure 31. 120 VAC or 240 VAC input receptacle, 2-pin (KME6-1775-H)

⚠ WARNING

Hazardous voltage. Before applying power to the control, confirm that male pins of the input power receptacle are electrically insulated to prevent unintentional contact with 120/240 VAC voltage. Failure to do so may result in severe personal injury or death.

T372.1

Form 6 microprocessor-based pole-mount recloser control

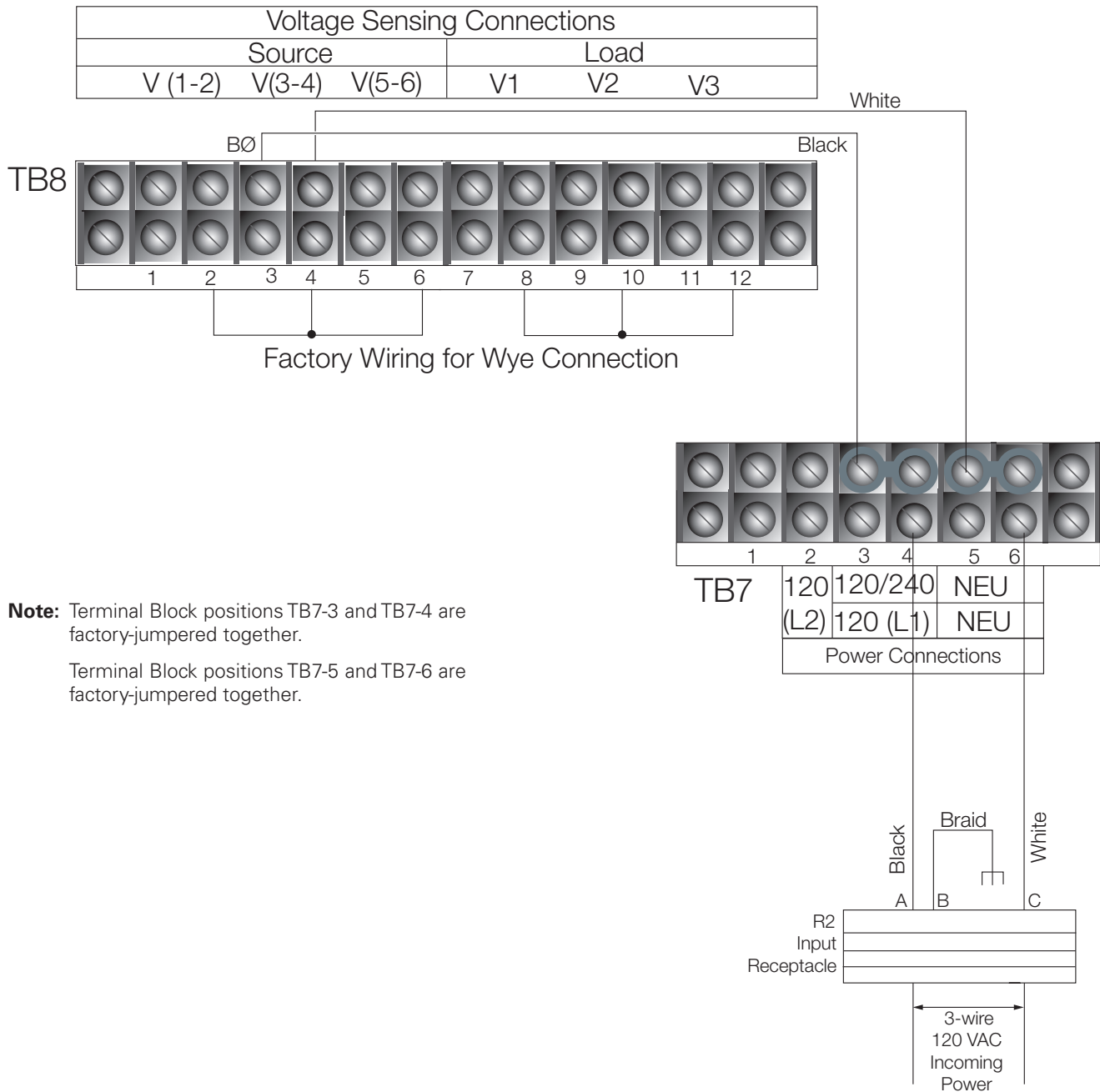

Note: Terminal Block positions TB7-3 and TB7-4 are factory-jumpered together.

Terminal Block positions TB7-5 and TB7-6 are factory-jumpered together.

Figure 32. 120 VAC input receptacle, 3-pin (KME6-1775-J)

⚠ WARNING

Hazardous voltage. Before applying power to the control, confirm that male pins of the input power receptacle are electrically insulated to prevent unintentional contact with 120/240 VAC voltage. Failure to do so may result in severe personal injury or death.

T372.1

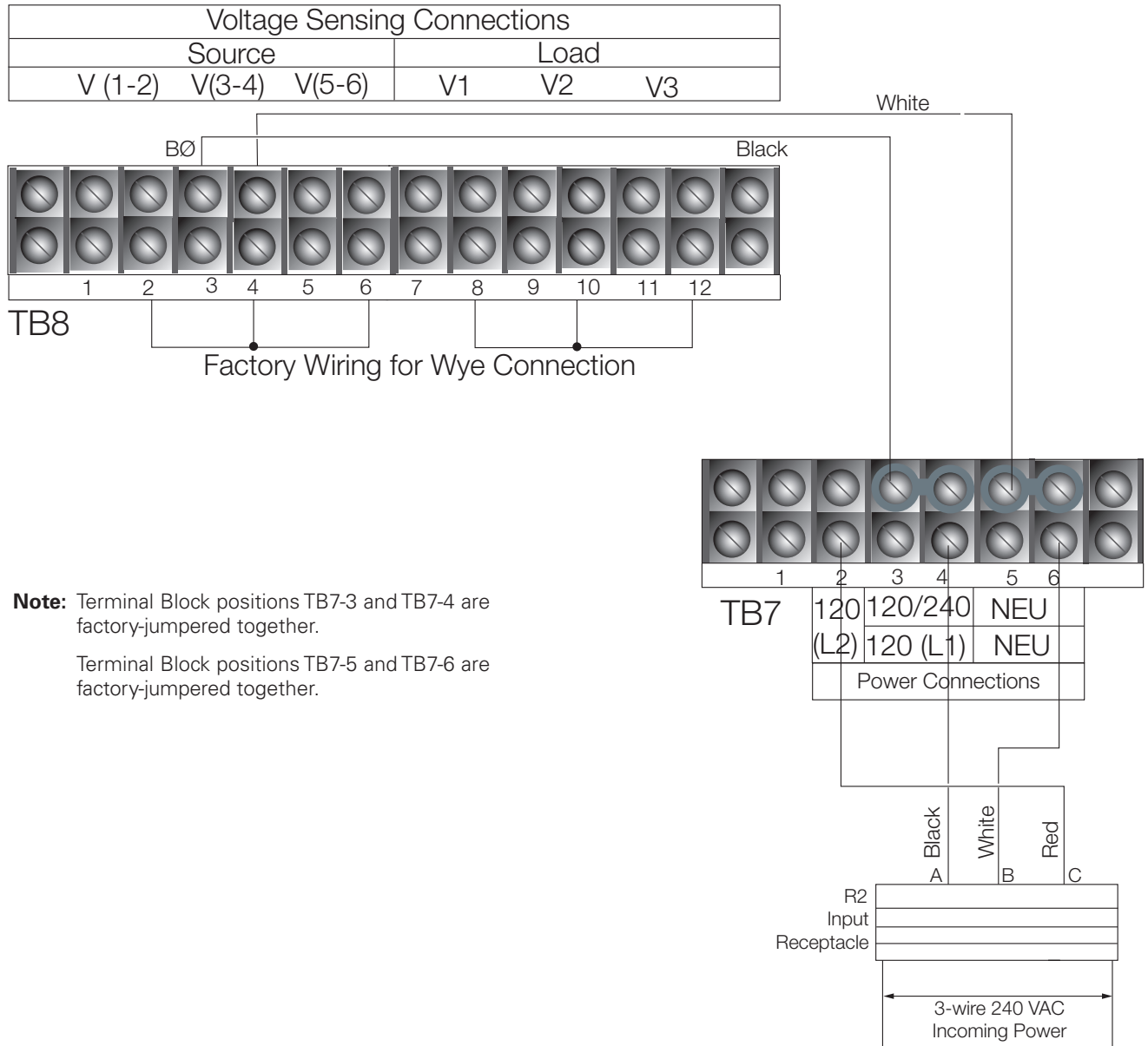

Figure 33. 240 VAC input receptacle, 3-pin (KME6-1775-K)

WARNING

Hazardous voltage. Before applying power to the control, confirm that male pins of the input power receptacle are electrically insulated to prevent unintentional contact with 120/240 VAC voltage. Failure to do so may result in severe personal injury or death.

T372.1

Form 6 microprocessor-based pole-mount recloser control

BCT terminal blocks accessory

The BCT Terminal Blocks (**Figure 34**) attach to the back of the control and provide a connection point for external 600:5 or 1200:5 multi-ratio bushing current transformers. BCT Terminal Blocks are available for both the load or source sides and include wire for all ratios of the BCT. Refer to **Table 10**.

Auxiliary terminal block accessory

An auxiliary terminal block and receptacle is available for three-stage auxiliary switch wiring. Refer to **Table 10**.

Cabinet ordering accessories

- AISI 304 stainless steel cabinet construction
- Three-point door latch

Table 10. Terminal blocks

Description	Catalog number
BCT shorting-type terminal block for (LOAD) bushings 2, 4, 6	KME6-1773-A
BCT shorting-type terminal block for (SOURCE) bushings 1, 3, 5	KME6-1773-B
Terminal block and receptacle for wiring of three-stage auxiliary switch, KA542R3	KME6-1801-1

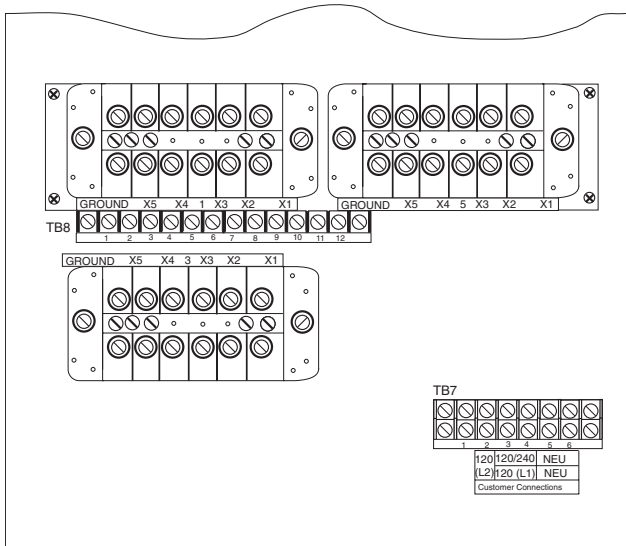

Figure 34. Form 6 pole-mount recloser control BCT terminal block accessory

Discrete interface board (DIF) option accessory

A Discrete Interface Board Option accessory provides eight configurable input control contacts and eight configurable output status contacts (**Figure 35**). The ordering options include: Standard (3 inputs / 5 outputs) or Additional (8 inputs / 8 outputs).

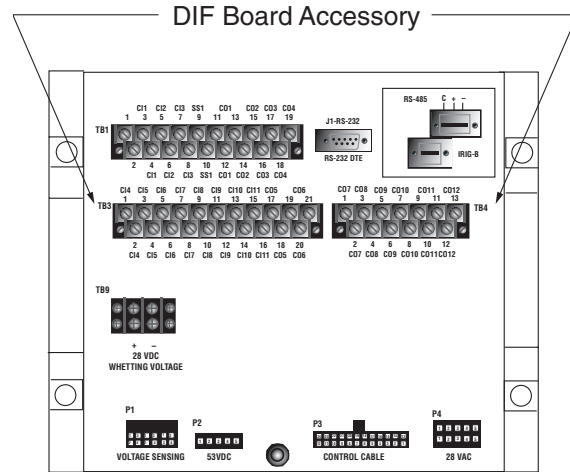

Figure 35. Form 6 recloser control discrete interface board accessory

Radio mounting accessory

The radio mounting accessory (**Figure 36**) is powered from a voltage regulated power supply factory-calibrated with an output of 13.8 VDC.

The radio power supply input is fused by a 1 Amp in-line fuse for a nominal voltage of 28 VDC. The output is 13.8 Vdc between P2-1 (+) and P2-2 (-) on the radio power supply circuit board with a maximum continuous watt rating of 17.25W @ 13.8 VDC.

Note: This output cannot be field-calibrated.

The radio will continue to operate during the loss of AC power as long as power is supplied from the battery. The power supply is designed to provide up to 40 Watts (peak) and is fused to isolate any potential radio problems without disturbing the protection system in the recloser control. Refer to **Table 11**.

Contact your Eaton representative for any additional voltage requirements.

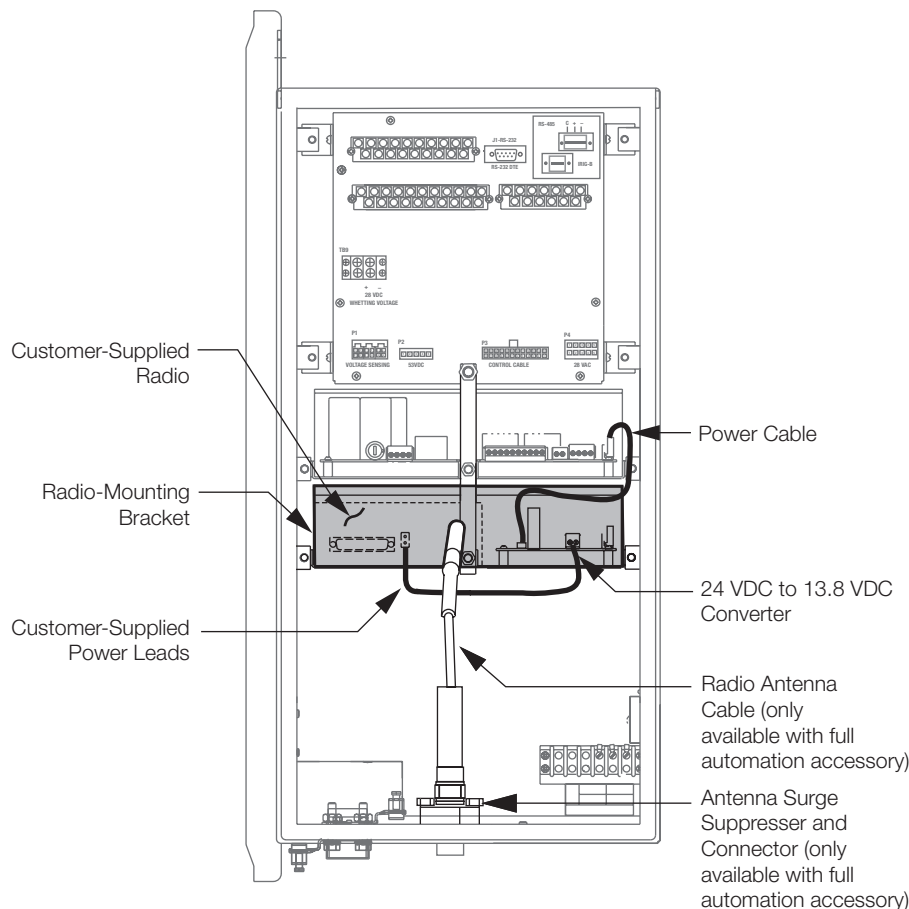

Figure 36. Form 6 recloser control radio mounting accessory

Table 11. Radio mounting accessories

Description	Catalog Number
Full Automation accessory 12 VDC radio provision (Radio and fiber-optic/RS232 interface not included)	KME6-1774-3
Automation accessory (bracket only) 12 VDC provision	KME6-1774-2

Communication board accessories

The Form 6 pole-mount control is equipped with a Communication Board Accessory (expansion bay) offering versatile support for modern communication media. Six distinct communication options (Figure 37) are available, providing two-way, real time digital communications with a remote terminal unit (RTU), wireless, telephone modem, Ethernet network, or other communication devices. The following options are available:

- No auxiliary communication card installed (standard)
- RS485 (isolated) Serial communication card
- Fiber-optic-based Serial Communication Card (ST)

- 10/100 Base-T dual Ethernet communication card (2* RJ-45)
- 100 Base-FX dual Ethernet communication card (2* MT-RJ)
- 10/100 Base-T, 100 Base-FX Ethernet communication card (RJ-45 + MT-RJ)

The expansion bay based Communication Board Accessory concept offers high versatility with respect to communication medium and protocol support. Additional accessories are being continuously developed. Contact your Eaton representative for the latest information regarding particular media and communication protocol support.

RS485 serial communication card

The RS485 serial communication card accessory provides means for establishing asynchronous link-based digital communications with the Form 6 pole-mount control. The Galvanic isolated (1000V DC) RS485 port uses a single shielded twisted pair connection and can support 32 devices in multi-drop configuration. Communication speed is controlled through software and can be set at: 1200, 2400, 4800, 9600, 19.2k, and 38.4k. Modbus can also be set at 576k.

Form 6 microprocessor-based pole-mount recloser control

Digital communications must be programmed through the Communications Workbench to ensure proper operation of the RS485 communication card accessory. Refer to *Service Information S280-70-4 (ProView 4.X.X) or S280-70-21 (ProView 5.X.X) Form 6 Microprocessor-Based Recloser Control Programming Guide* for additional protocol support information.

Fiber-optic based serial communication card

The Fiber-Optic based Serial Communication Card offers means of establishing asynchronous (RS-232 like) digital communications through multi-mode fiber media. The use of the fiber-optic based serial communication card accessory can enhance communication reliability, and provides excellent electrical isolation thus protecting transmitted data from extraneous electrical interference.

An optional fiber-optic-to-RS-232D converter with DB-9 connector (Catalog Number KME6-1875-1) is available for interfacing between an optical signal and a hard-wired RS-232 signal, when required. This converter is compatible with loop (ring) and point-to-point (star) configurations.

A pair of industry standard ST type fiber-optic connectors are mounted on the back of the board enabling customer connection to a digital communication system using fiber-optic cables (customer-supplied).

The fiber-optic link has separate receive (RX) and transmit (TX) ports operating at 820nm. Typical transmission distance is 2000m with 62.5/125µm multi-mode fiber. Consult your Eaton representative for availability of long haul solutions. Link communication speed is controlled through software and can be set at: 1200, 2400, 4800, 9600, 19.2k, and 38.4k. Modbus can also be set at 57.6k.

The fiber-optic accessory must be programmed through the Communications Workbench for the appropriate protocol. Refer to *Service Information S280-70-4 (ProView 4.X.X) or S280-70-21 (ProView 5.X.X) Form 6*

Microprocessor-Based Recloser Control Programming Guide for additional information.

The fiber-optic based serial accessory includes TX and RX indicating LEDs for verifying communications along with an echo / non echo switch for supporting ring / star fiber topologies.

When operated in a ring configuration, the toggle switch must be set in the ECHO position. In this mode, the fiber-optic card will repeat (pass through) all messages received on the RX fiber, and will respond to the Master station by first echoing the incoming command and then sending the response. This arrangement is best suited for creation of low cost multi device fiber loops. For reliable communications, the fiber loop system requires that all devices in the loop remain powered at all times, thus enabling unobstructed flow of information throughout the loop.

A more resilient system can be designed by using the fiber-optic ports in a point-to-point or multiple point-to-point (star) configuration. For this mode, the toggle switch must be set in the NON-ECHO mode. The Form 6 pole-mount control will respond to the Master station by sending a response only (total separation of Receive and Transmit fibers). Additional hardware (fiber-optic star coupler) is required to support the multiple point-to-point device configurations.

Ethernet communication cards

The Ethernet communication card accessory brings the Ethernet network connectivity to the Form 6 pole-mount recloser control platform. It is highly flexible, offering simultaneous support for multiple sessions, device management (ProView over TCP/IP) and SCADA communications (DNP3 over TCP/IP).

By natively supporting a set of widely accepted industry standards (TCP/IP, UDP/IP, OSI) the Ethernet communication accessory ensures seamless interoperability with other network devices.

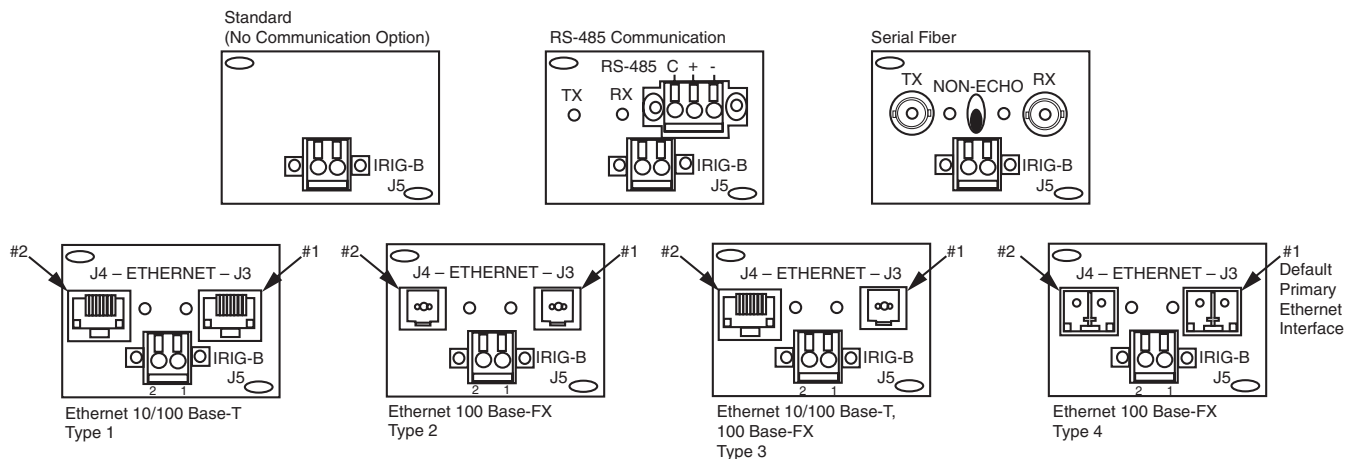

Figure 37. Back panel ethernet and communication options

The Ethernet communication card accessory is offered in 3 physical layer configurations (twisted pair and optical-fiber options) as shown in **Table 12**.

Table 12. Ethernet communication card configurations

Type	Card Configurations	Output Connectors	Communication Speed
1	10/100 Base-T	2 * RJ-45	10 / 100MBps (auto switching)
2	100 Base-FX (multi-mode fiber)	2 * MT-RJ	100MBps (full duplex)
3	10/100 Base-T, 100 Base-FX	RJ-45 + MT-RJ	10/100MBps and 100MBps
4	100 Base-FX, (single-mode fiber)	2 * LC	100MBps (full duplex)

Maximum link length is determined by the use of the particular physical layer implementation, and can be further constrained by the actual network configuration. In case of the 100Base-FX MT-RJ connector based implementation, maximum link length in excess of 2000m can be achieved with 62.5/125µm multi mode fiber. The fiber-optic link uses 1300nm wavelength, and can easily be interfaced to other 100Base-FX solutions (ST connector patch cord solution).

The Ethernet communication accessory card (**Figure 37**) is equipped with two physical ports configured to act as primary and standby LAN connections. Availability of the backup communication port enables creation of highly redundant Ethernet networks thus increasing the overall system reliability.

Note: Under normal network conditions, all communications will be channeled through the primary port (#1, **Figure 37**), with the standby port either logically disabled, or configured for fast automatic throw-over in case of the primary Ethernet link failure. Refer to *Service Information S280-70-4 (ProView 4.X.X) or S280-70-21 (ProView 5.X.X) Form 6 Microprocessor-Based Recloser Control Programming Guide* for additional Ethernet accessory configuration information.

Testing

⚠ **CAUTION**

Equipment misoperation. Do not connect this control to an energized recloser until all control settings have been properly programmed and verified. Refer to the programming information for this control. Failure to comply can result in control and recloser misoperation, equipment damage, and personal injury.

G110.3

IMPORTANT

The Form 6 control can be taken out of service for testing and placed back into service without de-energizing its recloser and interrupting the system. However, during the time the control is out of service, the recloser is inoperative.

Testing an installed control

The following tests to determine initial operation of the Form 6 pole-mount recloser control can be performed while connected to an operating recloser.

- Note:** These are the only tests performed on an installed, operating control.
- Verify operating status of all indicator lights by pressing and holding the LAMP TEST key for two seconds on the programming panel (**Figure 38**).
 - Check the operational values for currents, voltages, and other metering information.

Note: Scroll through the LCD display messages by pressing the \blacktriangle and \blacktriangledown cursor movement arrows underneath the LCD display on the programming panel (**Figure 38**).

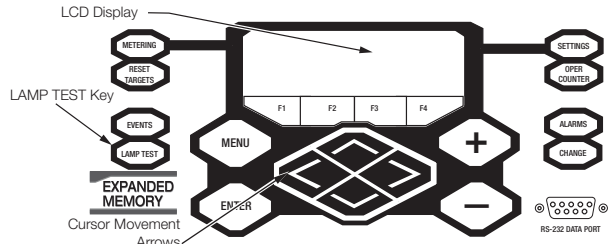

Figure 38. Lamp test button, LCD display, and cursor movement arrows

- Test battery operation as follows:
 - Note:** The battery test is blocked for 30 seconds upon power up of the control.
 - Note:** AC power can be either connected or disconnected for battery test.
 - A. Press the MENU button on the front panel.
 - B. Using the down arrow key, navigate to the BATTERY menu, and press ENTER.
 - C. Using the down arrow key, navigate to the TEST BATTERY menu and press ENTER.
 - D. Press the F4 button to test the battery.
- Note:** This message will appear on the programming panel LCD display: —TESTING—

The battery test results will display in the battery metering menu.

Form 6 microprocessor-based pole-mount recloser control

Note: Voltage should be between 25–31 VDC – with the higher voltage at colder temperatures.

Under normal conditions, with AC connected and a fully charged battery, the charging current should be less than 20 mA.

With AC connected and a discharged battery, the current range should be 20–450 mA.

With AC disconnected and the battery supplying the load, current will read -400 to -600 mA depending on accessories connected.

- Verify the Control OK LED is illuminated on the control operator panel (**Figure 39**). This indicates the presence of AC power.

Note: The control includes a Power Save feature that will turn off the backlit LCD display and all LEDs if no front panel keypad is pressed within ten minutes. Pressing the LAMP TEST key will reactivate the display and active LEDs.

All other tests described in this **Testing** section require the Form 6 pole-mount recloser control to be removed from service, connected to a bypassed recloser, or tested at a location where the proper testing equipment is available.

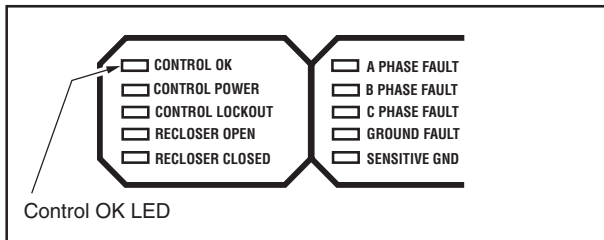

Figure 39. Control OK LED

Remove the control from service

IMPORTANT

Disconnect switches for AC sensing and power connections are necessary to isolate the Form 6 control for testing and servicing.

- Enable GND TRIP BLOCKED to disable the ground element.

Note: This prevents the control from tripping on imbalance as the control cable is connected and disconnected.

 - Press the CHANGE button on the Operator Panel to enter the CHANGE mode.
 - Press the GND TRIP BLOCKED button within ten seconds after entering the CHANGE mode.

Note: If the GND TRIP BLOCK button is not pressed within ten seconds, the function is not activated.
- Disconnect the 24 V control battery.

CAUTION

Hazardous voltage. Open CT secondaries can generate high voltages. Contact with CT pins of the disconnected cable can cause electric shock and may result in personal injury. Open recloser contacts and open disconnect switches before disconnecting control cable.

T204.3

IMPORTANT

Equipment misoperation. Disconnect all control power sources prior to disconnecting or reconnecting the control cable from the control. Failure to comply can result in recloser misoperation at the time of disconnection or reconnection of the control cable to the control.

T311.1

- Disconnect control cable from control.
- Remove control AC sensing and power connections from the control.

CAUTION

Hazardous Voltage. Cable conductors attached to controls will remain at 53 VDC and 120/240 VAC potential while connected to the control. Contact with any pins at the end of the cable directly or indirectly connected to a control can result in personal injury or equipment damage. Disconnect battery and external power sources in the control then remove control cable at control end before disconnecting from recloser end.

T312.3

- Remove any control input and status output wiring from TB1, TB3, and TB4 (**Figure 40**).
- Disconnect any serial communications ports and IRIG-B timing connections (**Figure 40**).

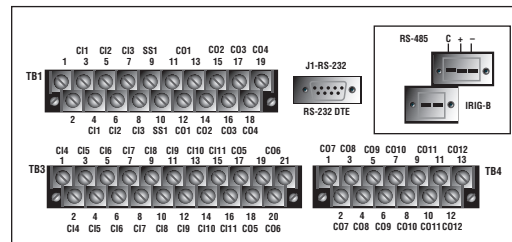

Figure 40. Back view of top half of Form 6 pole-mount recloser control

- Disconnect the ground from the control.
- Carefully transport the control to a suitable service facility.

Preliminary testing with no AC available

If the Form 6 control is not in service and requires energization for preliminary testing, it can be powered up with battery power only.

Note: Controls with expanded memory require battery voltage to be 23VDC minimum.

1. Open the rear door of the Form 6 pole-mount control cabinet and locate terminals TM1 and TM2 on the power supply circuit board (**Figure 41**).

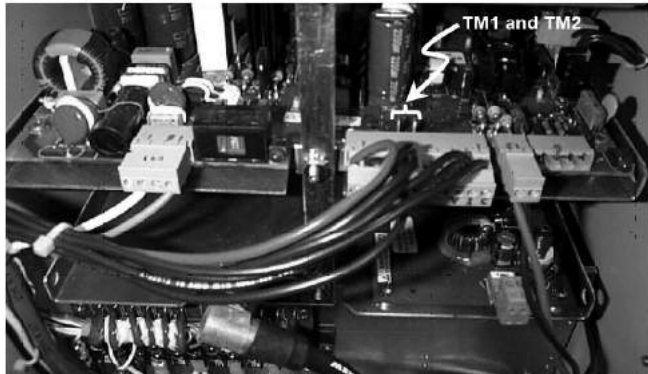

Figure 41. Location of terminals TM1 and TM2 on the power supply circuit board

2. Momentarily jumper terminals TM1 and TM2 together. (The control will power up.)
3. To power down the Form 6 control, unplug the battery (disconnect the black/red battery connector).
4. Perform a battery charging cycle. Refer to **Battery Charging** in the **Battery Test and Charging Procedures** section of these instructions.

IMPORTANT

While the Form 6 control is powered in this manner, the control battery is being continuously discharged. When the battery voltage drops to 22 VDC, the control will automatically power down.

If the battery is left in a discharged condition, the battery(s) will sustain permanent irreversible damage. Therefore, a battery charging cycle should always be performed after this procedure to bring the battery(s) back up to full charge.

Testing with type MET tester

The Type MET electronic recloser control tester (**Figure 42**) is used for testing the following functions of the Form 6 recloser control:

- Overcurrent Timing
- Reclose Time
- Operating Sequence
- Reset Time
- Minimum Trip Current
- High Current Trip and Lockout

The MET Tester is completely self-contained, capable of performing all required checks and tests from a simple verification of operation to a complete verification of all operating parameters.

Refer to *Service Information MN280067EN Type MET Electronic Recloser Control Tester Operating Instructions* for proper setup and use of the MET Tester.



Figure 42. Type MET electronic recloser control tester

Closing the recloser during testing

Electrical closing – solenoid-operated reclosers

Line voltage is required for automatic recloser operation during testing of reclosers equipped with a closing solenoid (except for reclosers equipped with the low voltage closing accessory).

WARNING

Hazardous voltage. Interconnect source leads X and Y and ground solidly to the recloser tank (Figure 45). Do not connect lead Z to any other phase or mechanical ground. Dangerous voltages to ground exist on the phase connected to lead Z. Solidly ground all equipment. Failure to comply can result in severe personal injury and/or equipment damage.

T224.1

For on-line testing, bypass the recloser, open the load-side disconnects and keep the source-side disconnects closed. This will remove the recloser from service, but will keep line voltage supplied to the closing solenoid (**Figure 43**).

WARNING

Hazardous voltage. The switchgear (apparatus and control) and high-voltage transformer must be in a test cage or similar protected area to prevent accidental contact with the high-voltage parts.

Solidly ground all equipment. Failure to comply can result in death, severe personal injury, and equipment damage.

T221.5

Form 6 microprocessor-based pole-mount recloser control

For shop testing, the closing solenoid voltage is supplied by back-feeding a transformer with a low-side rating equal to the voltage rating of an available power source, and a high-side rating equal to the voltage rating of the recloser (**Figure 45**). A 75 kVA transformer of the proper voltage rating with an impedance drop of approximately 3% is satisfactory. The AC source must have a comparable impedance drop.

A test circuit for these solenoid-closed reclosers is shown in **Figure 45**. The following equipment is required for the recommended shop testing setup:

Note: Solenoid-closed reclosers equipped with a 120- or 240- VAC low-voltage closing coil accessory can be tested as shown in **Figure 46**.

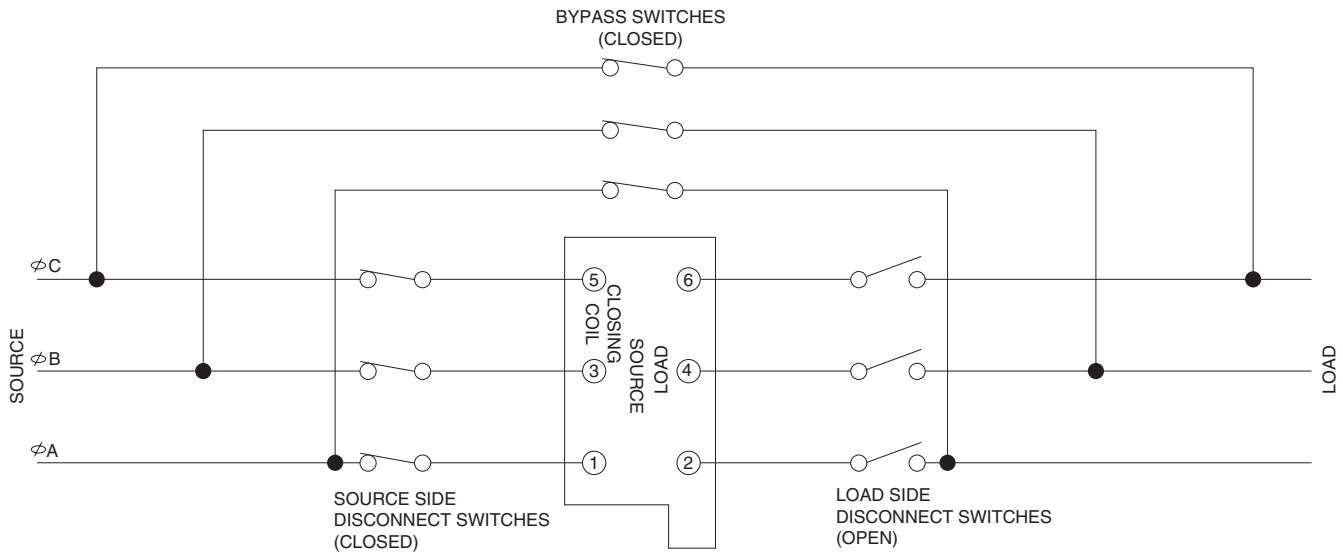

Figure 43. Closing source-side switches of a bypassed “on-line” recloser provides closing solenoid power for automatic operation during testing

- Variable Autotransformer T1, 230 Volts, 20 Amps.
- Low-Voltage transformer T2 to simulate fault conditions.

Ratio and size will depend upon the maximum current to be used. The recloser presents a low impedance to the transformer, so secondary voltage must be only high enough to force the required current through the secondary of the transformer and the recloser.

Note: An alternative method of providing the necessary current through the transformer is shown in **Figure 44**.

- High-Voltage T3 to operate the closing solenoid.
- The closing coil requirement is approximately 200 kVA during the two-to-three cycle closing operation. The solenoid coil operating voltage must be maintained at the recloser bushings during the cycle interval the closing coil is energized. This procedure is not used on reclosers equipped with the low-voltage closing accessory.
 - Ammeter with a rating based on the level of test current.
 - Current-actuated timer.

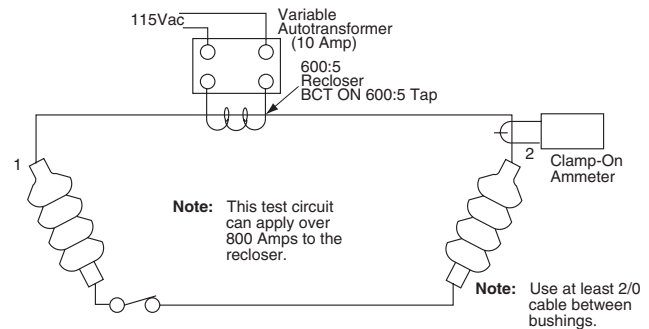
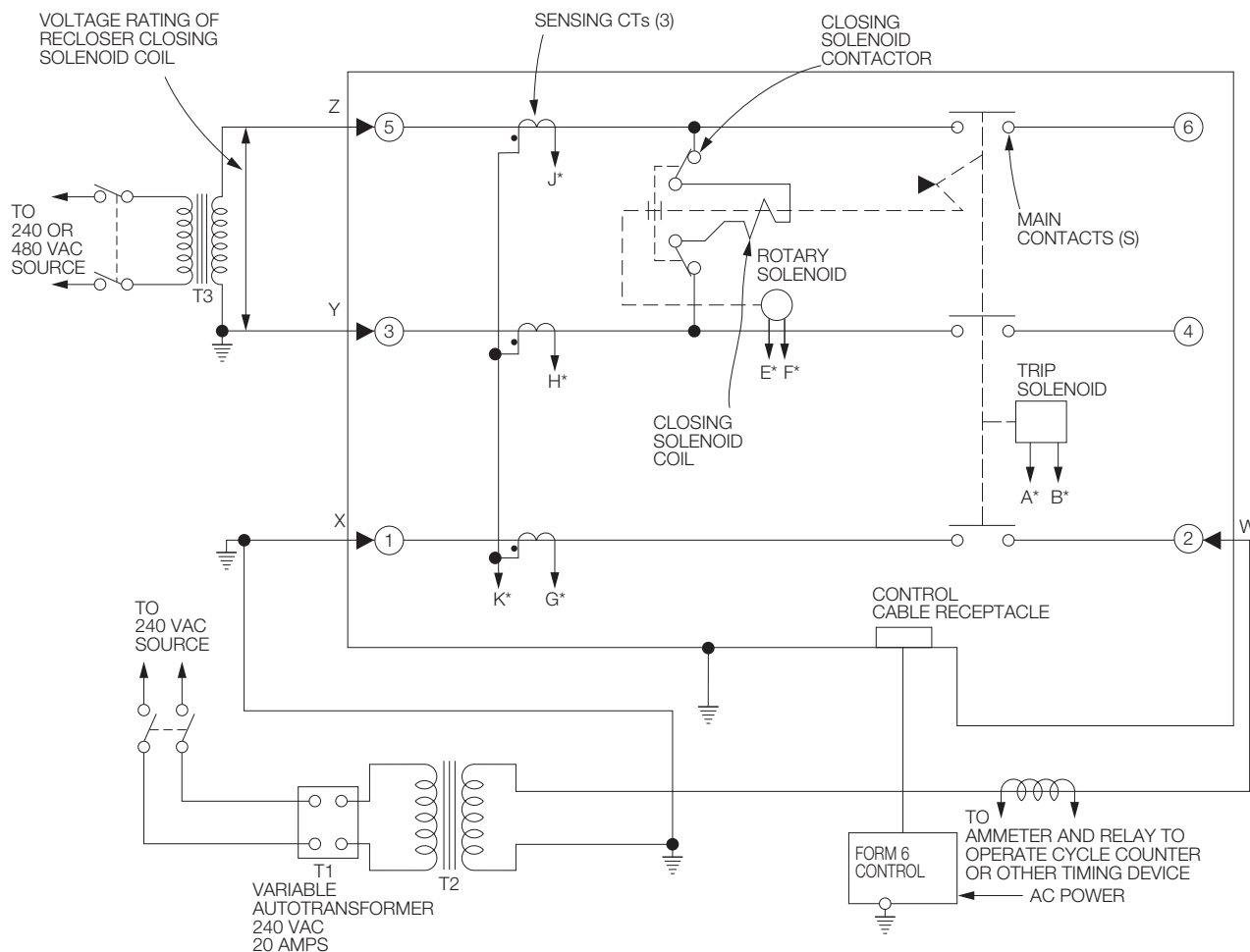

Figure 44. Alternate method of producing variable line current (substitute for T2 and W-X circuit in Figure 45 and Figure 46)



*Indicates control cable receptacle pin/socket designation.

Figure 45. Suggested test circuit for high voltage “shop-testing” solenoid-closing reclosers

Electrical closing – motor-operated low-voltage closing solenoid / auxiliary-powered NOVA reclosers

⚠ WARNING

Hazardous voltage. Solidly ground all equipment. Failure to comply can result in death, severe personal injury, and equipment damage.

T223.2

High-voltage is not required for reclosers utilizing a motor-operated closing mechanism, low voltage closing, or auxiliary-powered NOVA recloser. For information on energizing the recloser, refer to the appropriate recloser installation manual. Low voltage supply can use either 120 or 240 VAC for input power. Check the name plate on the recloser to verify the correct closing power requirements.

Figure 46 shows a test circuit for motor-operated, low-voltage solenoid-closing, and auxiliary-powered NOVA reclosers. Since these reclosers require only a low voltage source for closing, high-voltage transformer T3 and its protective cage is eliminated. All other equipment is the same as the test equipment shown in Figure 45.

Form 6 microprocessor-based pole-mount recloser control

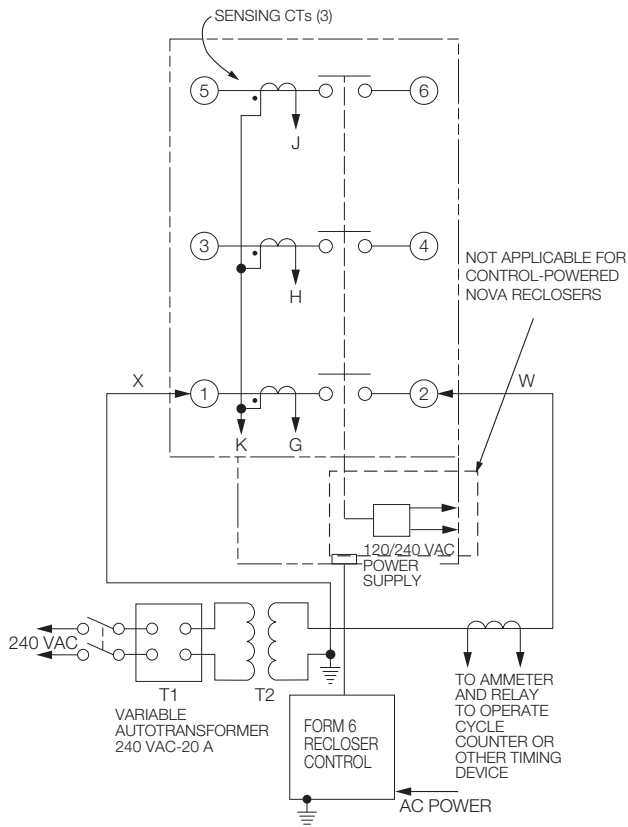

Figure 46. Suggested test circuit for motor-operated, solenoid-closing reclosers with low-voltage closing

Manual closing – solenoid-operated reclosers

WARNING

Explosion hazard. Excessive Contact Arcing. Do not use the manual closing tool to close an oil-insulated energized recloser. Closing an energized oil-insulated recloser with a manual closing tool can cause excessive contact arcing, rapid build-up of gas within the equipment, and possible explosion which can cause death, severe personal injury, and equipment damage.

T203.2

If high-voltage for operating the closing solenoid is not available, manual closing can be substituted for electrical closing. However, not all control settings can be checked since manual closing is not synchronized with the closing coil control circuit in the control.

Follow these steps to manually close the recloser:

1. Remove the closing tool port cover and gasket from the side of the recloser head casting.

NOTICE

Equipment damage. Do not turn the manual closing tool more than one-quarter turn clockwise. Forcing the tool beyond the mechanism stop may shear the pin on the closing shaft of the recloser.

T222.0

2. Insert the tee-handled tool (available as an accessory) into the port, engaging the pin on the closing shaft (Figure 47).
3. Close the recloser by placing the yellow operating handle (located under the sleethood) into the up or CLOSED position and turning the closing tool one-quarter turn clockwise.
4. After each trip operation, about 1/2 second elapses while the closing solenoid plunger is moving upward to reset the main toggle latch.
5. After the main toggle latch resets, the recloser can be closed again by operating the manual closing tool.
6. Replace the gasket and port cover on the recloser head after testing has been completed.

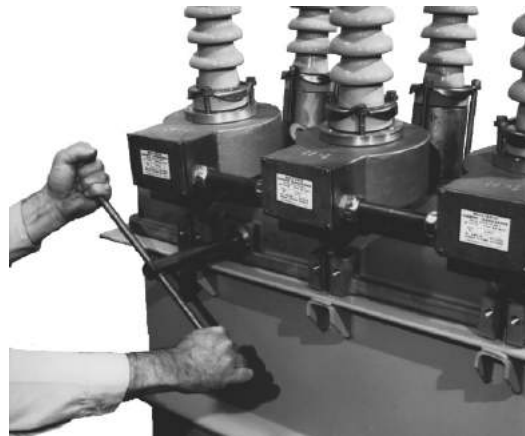

Figure 47. Using a manual closing tool to operate the recloser

Battery test and charging procedures

Test procedure for installed battery

Follow the procedure below to perform a battery test in the Form 6 pole-mount control. The values in the test procedures are based on testing at 25 °C (77 °F).

The condition of the Form 6 pole-mount control battery can be determined by using the Battery Test function in the BATTERY MENU. No external current/voltage meter is necessary for testing.

Alarm Conditions:

- During a manual battery test a 5Ω, 55 watt resistor is placed across the battery terminals for approximately 5 seconds. The Form 6 control measures the battery voltage, if the voltage drops below 22.8 VDC for one full second, the ALARM LED (battery alarm) is illuminated.
- When the Form 6 pole-mount control is disconnected from AC power and the control battery drops below 23.5 VDC for 60 seconds, the ALARM LED will illuminate. If the battery voltage continues to decay and drops below 22 VDC, the Form 6 control will shut down.

Note: The battery test is blocked for 30 seconds upon power up of the control.

Note: AC power can be either connected or disconnected for battery test.

Note: If the battery voltage drops below 19V, the battery must be charged by the external battery charger KA43ME7001.

1. Press the MENU button on the front panel.
2. Using the down arrow key, navigate to the BATTERY menu and press ENTER.
3. Using the down arrow key, navigate to the TEST BATTERY menu and press ENTER.
4. Press the F4 button to test the battery. The battery test results will display in the battery metering menu.

Note: Voltage should be between 25–31 VDC with the higher voltage at colder temperatures.

Under normal conditions, with AC connected and a fully charged battery, the charging current should be less than 20 mA.

With AC connected and a discharged battery, the current range should be between 20 and less than 450 mA. Current of 450 mA or greater indicates a problem with the charging circuit on the pole-mount power supply.

With AC disconnected and the battery supplying the load, current will read -400 to -600 mA depending on connected accessories.

Test procedure for uninstalled battery

The entire process should be conducted in a clean environment, such as a repair shop.

Refer to **Table 13** and follow this procedure to perform a bench test on a control battery in a service shop:

1. Remove the control from service. Refer to **Remove the control from service** procedure within the **Testing** section of this manual.
2. Remove the battery from the control and carefully transport it to a suitable service facility.
3. Measure battery voltage.
4. Apply test load and measure battery voltage after 5 seconds of load to determine voltage drop. Refer to **Table 13** for Bench Test Load Condition.
5. Remove test load.

If the battery fails the test or is at least four years old, it should be replaced. Refer to **Table 13** for battery catalog part numbers.

Table 13. Control battery bench testing and replacement information

Control type	Battery catalog part #	Voltage	Type	Amp/hour	Bench test load condition for 5 sec.	Acceptable voltage drop at end of test load
Form 6 Pole-mount (standard capacity)	KME4-215	24v	Lead Acid	8	5Ω 55 watt	3v or less
Form 6 Pole-mount (high capacity)	KME5-134-1	24v (two 12v batteries)	Lead Acid	13	5Ω 55 watt	2v or less

Form 6 microprocessor-based pole-mount recloser control

Battery charging

If it is not possible to charge the battery with the control's built-in charger, a KME5-60-1 (120 VAC) portable bench type battery charger kit is available, which includes the KA43ME7001 Battery Charger (**Figure 48**) and the KME5-325-1 Adapter Cable. Refer to *S280-79-14 KA43ME7001 Portable Lead Acid Battery Charger Instructions* for additional information.

IMPORTANT

Do not attempt to charge a lead acid battery below 2 VDC with the KA43ME7001 charger. The charger requires a minimal voltage to sense a battery is connected.

If the lead acid battery is below 19 VDC for over 2 days, replace the battery. The expired battery should be disposed of in an environmentally responsible manner. Consult local regulations for proper battery disposal.

Charge the battery with a KA43ME7001 (120 VAC) portable charger as applicable:

- Form 6 Pole-mount Recloser Control (**Standard Capacity**) – Connect the battery directly to the KA43ME7001 charger. The charger continuously monitors the battery voltage.
- Form 6 Pole-mount Recloser Control (**High Capacity**) – Use adapter KME5-325-1 to connect the two 12 volt batteries to the KA43ME7001 charger.

IMPORTANT

Never connect a single 12 volt battery to the KA43ME7001 charger. Use adapter KME5-325-1 with the battery assembly when connecting the charger to the two 12 volt batteries.

Note: A yellow LED indicator on the body of the charger illuminates when charging. A green LED indicator illuminates when the charge is complete.

The charger senses when the battery voltage reaches 2.27 volts per cell, then the charge rate reduces to maintain a trickle charge.

The yellow LED flickers to indicate the battery has reached a full charge. This process can take up to 24 hours.

Refer to **Table 14** for additional battery charging accessories.

Table 14. Battery charging accessories

Description	Catalog number
120 VAC battery charger accessory	KME5-60-1



Figure 48. KA43ME7001 battery charger

Return the control to service

⚠ CAUTION

Equipment misoperation. Do not connect this control to an energized recloser until all control settings have been properly programmed and verified. Refer to the programming information for this control. Failure to comply can result in control and recloser misoperation, equipment damage, and personal injury.

G110.3

After the required work is completed, disconnect the control from the test set and follow this procedure to return the control to service:

1. While still in service shop, appropriate personnel must verify that all control settings are correct.
2. Reconnect the ground cable to the control.
3. Control cable properly connected and supported.
4. Plug in the control battery.

Note: The Form 6 pole-mount recloser control will not power up until AC power is applied.

⚠ CAUTION

Equipment misoperation. Verify that the 120/240 VAC selector switch is correctly set for incoming voltage. Failure to comply may cause misoperation (unintentional operation) of the control and/or equipment damage resulting in personal injury.

T278.0

5. Verify the selector switch on the Power Supply/Battery Charger Board is set to the correct position based upon the incoming power supply:
 - For 120 VAC incoming power, the selector switch must be set to the 115V position.
 - For 240 VAC incoming power, the selector switch must be set to the 230V position.
6. Apply AC power to the control.
7. Disable GND TRIP BLOCKED.
 - A. Press the CHANGE button on the Operator Panel to enter the CHANGE mode.
 - B. Depress the GND TRIP BLOCKED button within ten seconds after entering the CHANGE mode.
8. Verify the control clock is set to the current time after AC power has been reapplied.

Note: Once selected (or after ten seconds), the control returns to normal operation.

Note: The control clock may require resetting if the operating power has been disconnected for more than thirty days. Refer to *Service Information S280-70-4 (ProView 4.X.X) or S280-70-21 (ProView 5.X.X) Form 6 Microprocessor-Based Recloser Control Programming Guide* for information on setting the control clock.

Recloser VTC interface

Control-Powered Type NOVA reclosers with serial numbers 100,000 and above, as listed in **Table 15**, require a VTC-ready control. They are equipped with a 19-pin control cable receptacle and can be identified by labels prominently displayed on the bottom of the recloser tank and on the side near the 19-pin receptacle, as shown in **Figure 49** below.

For more information on the Control-Powered NOVA Interface, refer to *Service Information S280-42-1*.

IMPORTANT

Equipment misoperation. The control-powered NOVA reclosers that require a VTC interface must be used with VTC-ready controls. Failure to use a VTC-ready control will result in failure to trip or close.

G144.0

Table 15. Serial number break for control-powered NOVA Reclosers with VTC

Control-powered NOVA	Serial no.
NOVA15	100,000
NOVA27	100,000
NOVA38	100,000

Note: Control-powered NOVA reclosers with serial numbers below those listed in **Table 15** do not require a VTC-ready control. Refer to the recloser nameplate for the serial number.

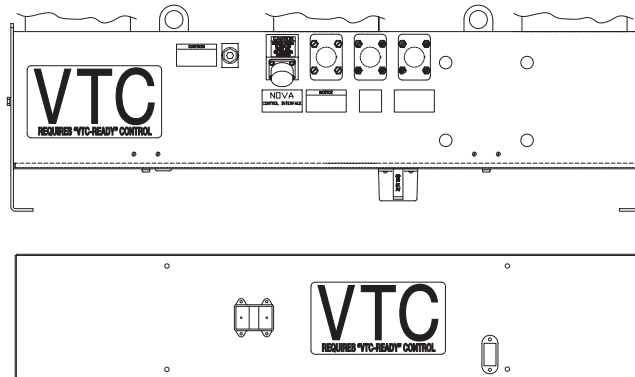

Figure 49. Receptacle side view and bottom view of NOVA recloser tank, showing placement of VTC label

Control VTC interface

All Form 5 and Form 6 recloser controls that have the control-powered interface with serial numbers over those shown in **Table 16** are VTC-ready. Catalog numbers for these controls begin with KME5B, KME5D, KME6P2B, or KME6PBL5. These controls have a 19-pin control cable receptacle and can be identified by the following label displayed on the bottom of the control cabinet, as shown in **Figure 50**.

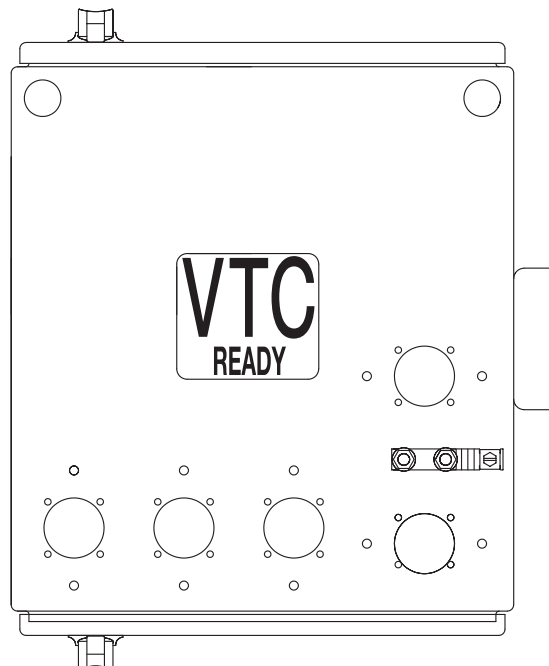

Figure 50. Bottom view of Form 6 recloser control showing location of VTC label

Form 6 microprocessor-based pole-mount recloser control

Note: VTC-ready controls can also be used with control-powered NOVA reclosers with serial numbers below 10,000.

VTC control retrofit kits are available for Form 5 or Form 6 recloser controls with serial numbers below those shown in **Table 16** to make these controls compatible with control-powered NOVA reclosers that require a VTC interface. Catalog numbers for these kits are listed in **Table 17**. To order these kits or to obtain information on how to make a Form 4C recloser VTC-ready, contact your Eaton representative.

Table 16. Serial number break for VTC-ready recloser controls

Control model	Catalog no.	Serial no.
Form 5 pole-mount control	KME5B	12669
Form 5 LS control	KME5D	2922
Form 6 pole-mount control	KME6P2B	10015
Form 6 LS control	KME6PBLS	10012

Note: Refer to the control nameplate for the serial number.

Table 17. Catalog numbers for control VTC retrofit kits

Control model	Catalog no.
Form 5	KME5-728-1
Form 6 with serial number above 10,000	KME6-728-1
Form 6 with serial number below 10,000	KME6-728-2
Form 6 LS	KME6-728-1

Additional information

CAUTION

This equipment requires routine inspection and maintenance to ensure proper operation. If it is not maintained, it can fail to operate properly. Improper operation can cause equipment damage and possible personal injury.

G105.1

Replacement kits

Replacement kits for the Form 6 pole-mount control are available through the factory Service Department. To order these kits, refer to the Replacement Parts price list for catalog numbers and pricing. Contact your Eaton representative for additional information and order procedures.

Factory-authorized service centers

Factory-authorized service centers are located throughout the continental United States to provide maintenance, repair and testing services for Eaton Cooper Power series controls and reclosers. For further information, contact your Eaton representative.

Factory maintenance classes

The factory service department offers a basic testing and troubleshooting course for the Form 6 microprocessor-based electronic recloser control. This course, taught by experienced service technicians, is held at the factory's in-house training facility. For additional information, contact your Eaton representative.

Type MET recloser control tester

A 30-minute video program KSPV7 Type MET Electronic Recloser Control Tester Operation and Testing Procedures is available as a supplemental training aid for service personnel.

This page is intentionally left blank.



Eaton
1000 Eaton Boulevard
Cleveland, OH 44122
United States
Eaton.com

Eaton's Power Systems Division
2300 Badger Drive
Waukesha, WI 53188
United States
Eaton.com/cooperpowerseries

© 2018 Eaton
All Rights Reserved
Printed in USA
Publication No. MN280077EN
KA2048-630 Rev: 07
July 2018

Eaton is a registered trademark.

All trademarks are property
of their respective owners.

For Eaton's Cooper Power series product
information
call 1-877-277-4636 or visit:
www.eaton.com/cooperpowerseries.