

## Form 6 NX-T microprocessor-based pole-mount recloser control installation and operation instructions



## **DISCLAIMER OF WARRANTIES AND LIMITATION OF LIABILITY**

The information, recommendations, descriptions and safety notations in this document are based on Eaton Corporation's ("Eaton") experience and judgment and may not cover all contingencies. If further information is required, an Eaton sales office should be consulted. Sale of the product shown in this literature is subject to the terms and conditions outlined in appropriate Eaton selling policies or other contractual agreement between Eaton and the purchaser.

THERE ARE NO UNDERSTANDINGS, AGREEMENTS, WARRANTIES, EXPRESSED OR IMPLIED, INCLUDING WARRANTIES OF FITNESS FOR A PARTICULAR PURPOSE OR MERCHANTABILITY, OTHER THAN THOSE SPECIFICALLY SET OUT IN ANY EXISTING CONTRACT BETWEEN THE PARTIES. ANY SUCH CONTRACT STATES THE ENTIRE OBLIGATION OF EATON. THE CONTENTS OF THIS DOCUMENT SHALL NOT BECOME PART OF OR MODIFY ANY CONTRACT BETWEEN THE PARTIES.

In no event will Eaton be responsible to the purchaser or user in contract, in tort (including negligence), strict liability or otherwise for any special, indirect, incidental or consequential damage or loss whatsoever, including but not limited to damage or loss of use of equipment, plant or power system, cost of capital, loss of power, additional expenses in the use of existing power facilities, or claims against the purchaser or user by its customers resulting from the use of the information, recommendations and descriptions contained herein. The information contained in this manual is subject to change without notice.

# Contents

<b>DISCLAIMER OF WARRANTIES AND LIMITATION OF LIABILITY</b> .....	<b>ii</b>
<b>SAFETY FOR LIFE</b> .....	<b>iv</b>
<b>SAFETY INFORMATION</b> .....	<b>iv</b>
Safety instructions .....	iv
<b>PRODUCT INFORMATION</b> .....	<b>1</b>
Introduction .....	1
ANSI standards .....	1
Quality standards .....	1
Acceptance and initial inspection .....	1
Handling and storage .....	1
Control power .....	1
Control battery .....	2
Battery replacement and disposal .....	2
Operation upon loss of AC power .....	2
<b>FORM 6 NX-T CONTROL DESCRIPTION</b> .....	<b>3</b>
Description .....	3
Theory of operation .....	3
Control front panel .....	4
Front panel text messaging .....	4
Programming panel .....	5
Operating panel .....	7
Three-phase trip – three-phase lockout (ganged) ..	9
Single-phase trip – three-phase lockout .....	9
Single-phase trip – single-phase lockout .....	9
Control features .....	9
Communications .....	12
Control information .....	13
Control back panel .....	13
<b>INSTALLATION PROCEDURE</b> .....	<b>14</b>
Initial programming prior to installation .....	14
Control/recloser compatibility .....	14
Duty cycle monitor .....	14
Control cable .....	14
Integrated junction box .....	15
Mounting the control .....	15
Locking the control .....	15
Grounding the control .....	17
Customer connections for AC power .....	20
Before placing the control and the recloser into service .....	29
Using removable inserts .....	30
<b>ACCESSORIES</b> .....	<b>31</b>
Incoming power receptacles .....	31
Discrete interface board (DIF) option accessory ..	31
Cable locking sleeves .....	32
RS-232 cable .....	32
Stainless steel cabinet .....	32
120 VAC GFI duplex outlet .....	32
Internal voltage sensing and load side sensing ..	32
Radio mounting accessory .....	32
Communication board accessory .....	32
<b>TESTING</b> .....	<b>34</b>
Testing an installed control .....	34
Remove the control from service .....	35
Preliminary testing with no AC available .....	36
Electrical testing of NOVA NX-T .....	36
Battery test and charging procedures .....	37
Return the control to service .....	38
<b>ADDITIONAL INFORMATION</b> .....	<b>39</b>
Replacement kits .....	39
Factory-authorized service centers .....	39
Factory maintenance classes .....	39



## Safety for life



Eaton meets or exceeds all applicable industry standards relating to product safety in its Cooper Power™ series products. We actively promote safe practices in the use and maintenance of our products through our service literature, instructional training programs, and the continuous efforts of all Eaton employees involved in product design, manufacture, marketing, and service.

We strongly urge that you always follow all locally-approved safety procedures and safety instructions when working around high-voltage lines and equipment, and support our “Safety For Life” mission.

## Safety information

The instructions in this manual are not intended as a substitute for proper training or adequate experience in the safe operation of the equipment described. Only competent technicians who are familiar with this equipment should install, operate, and service it.

A competent technician has these qualifications:

- Is thoroughly familiar with these instructions.
- Is trained in industry-accepted high- and low-voltage safe operating practices and procedures.
- Is trained and authorized to energize, de-energize, clear, and ground power distribution equipment.
- Is trained in the care and use of protective equipment such as arc flash clothing, safety glasses, face shield, hard hat, rubber gloves, clampstick, hotstick, etc.

Following is important safety information. For safe installation and operation of this equipment, be sure to read and understand all cautions and warnings.

### Hazard Statement Definitions

This manual may contain four types of hazard statements:

#### DANGER

Indicates an imminently hazardous situation which, if not avoided, will result in death or serious injury.

#### WARNING

Indicates a potentially hazardous situation which, if not avoided, could result in death or serious injury.

#### CAUTION

Indicates a potentially hazardous situation which, if not avoided, may result in minor or moderate injury.

#### NOTICE

Indicates a potentially hazardous situation which, if not avoided, may result in equipment damage only.

### Safety instructions

Following are general caution and warning statements that apply to this equipment. Additional statements, related to specific tasks and procedures, are located throughout the manual.

#### DANGER

**Hazardous voltage. Contact with hazardous voltage will cause death or severe personal injury. Follow all locally-approved safety procedures when working around high- and low-voltage lines and equipment.**

G103.3

#### WARNING

**Before installing, operating, maintaining, or testing this equipment, carefully read and understand the contents of this manual. Improper operation, handling, or maintenance can result in death, severe personal injury, and equipment damage.**

G101.0

#### WARNING

**This equipment is not intended to protect human life. Follow all locally-approved procedures and safety practices when installing or operating this equipment. Failure to comply can result in death, severe personal injury, and equipment damage.**

G101.1

#### WARNING

**Power distribution and transmission equipment must be properly selected for the intended application. It must be installed and serviced by competent personnel who have been trained and understand proper safety procedures. These instructions are written for such personnel and are not a substitute for adequate training and experience in safety procedures. Failure to properly select, install, or maintain power distribution and transmission equipment can result in death, severe personal injury, and equipment damage.**

G122.2

#### WARNING

**Overlapping zones of protection are required. Upstream protection device settings must provide adequate overcurrent protection in the event of a system or product failure. Failure to properly select appropriate upstream coordination protection can result in death, severe personal injury, and equipment damage.**

G172.0

## Product information

### Introduction

*Service Information MN280088EN* provides installation and operation instructions for the Form 6 NX-T pole-mount recloser control.

Refer to the below information for ProView software:

- *Service Information S280-70-23 Form 6 NX-T Recloser Control Programming Guide: ProView 5.X.X software*

The Form 6 NX-T control is designed for use with the below recloser only:

- NOVA NX-T reclosers. Refer to *Service Information MN280087EN NOVA NX-T Recloser Installation and Operation Instructions*.

### Read this manual first

Read and understand the contents of this manual and follow all locally approved procedures and safety practices before installing or operating this equipment.

### Additional information

These instructions cannot cover all details or variations in the equipment, procedures, or process described, nor provide directions for meeting every possible contingency during installation, operation, or maintenance. When additional information is desired to satisfy a problem not covered sufficiently for the user's purpose, contact your Eaton representative.

### ANSI standards

Eaton Cooper Power series reclosers are designed and tested in accordance with the following ANSI standards: C37.60 and C37.85 and ANSI Guide C37.61.

### Quality standards

ISO 9001-Certified Quality Management System

### Acceptance and initial inspection

Each Form 6 NX-T recloser control is completely assembled, tested, and inspected at the factory. It is carefully calibrated, adjusted and in good condition when accepted by the carrier for shipment.

Upon receipt, inspect the carton for signs of damage. Unpack the control and inspect it thoroughly for damage incurred during shipment. If damage is discovered, file a claim with the carrier immediately.

### Handling and storage

Be careful during handling and storage of the control to minimize the possibility of damage. If the control is to be stored for any length of time prior to installation, provide a clean, dry storage area. If storage is in a humid atmosphere, make provisions to keep the control circuitry energized.

**Note:** To energize the control, apply AC power to the AC supply input terminal block located in the lower right hand corner of the back panel of the control. Refer to the **Customer connections for AC power** section in this manual.

### Control battery storage and charging

The 24 VDC control battery in the Form 6 NX-T recloser control is fully charged prior to shipment and is ready for use.

## IMPORTANT

To maintain sufficient charge to operate the control and prevent battery cell damage, the sealed lead-acid batteries should be charged after no more than three months of storage.

Temperature has an effect on battery life. Sealed lead acid batteries should be stored, fully charged, at room temperature. Never store lead acid batteries at temperatures exceeding 117 °F (47 °C), as damage can result in approximately one month.

The batteries must be tested and charged for 24 hours following every three months of storage from the last test date. A separate portable charger accessory is available. Catalog Number KA43ME7001 provides a 120 Volt battery charger to power individual batteries.

## IMPORTANT

Connect the control battery before AC power is connected to the control's AC supply Input Terminal Block. The battery must be disconnected and removed prior to shipping. The battery must be disconnected prior to storing the control. See **Figure 1**.

**Note:** When shipped from the factory, the battery will be in the same carton as the control. The battery leads will be taped to the battery casing. Connect the battery plugs into the mating connectors to complete the battery circuit.

### Control power

The control is powered from 120 or 240 VAC. The selector switch on the power supply board allows the user to select between 120 VAC or 240 VAC.

**Note:** The selector switch is factory-set for each control based upon the customer order requirement.

# Form 6 NX-T microprocessor-based pole-mount recloser control

## Control battery

### Control battery installation

- The control is shipped with the battery not installed.
- Do not transport any Form 6 control with the battery inside the control enclosure.
- The battery shall be installed only after the control has been mounted.

### Battery installation 13 Ahr battery

1. Open and hold up Velcro strap.
2. Orient the first battery with the terminals towards the back of the control and place battery against back of battery tray.
3. Orient the 2<sup>nd</sup> battery with the terminals toward the front of the control and place battery in the battery tray.
4. Feed strap through strap slot in battery tray and tighten the strap.
5. Fold the strap up and over, attaching the end of the strap to the middle of the strap. See **Figure 1**.
6. Connect the red and black connector from the battery to the mating red and black connector from the control to complete the battery installation process.



**Figure 1. 24 Volt DC 13 Ahr battery strapping**

### Battery removal

1. Disconnect the red and black connector the battery to the control.
2. Lift up the Velcro strapping. Do not remove strap from mounting tray slots.
3. Carefully remove battery.
4. Replace according to battery installation procedure.

### Battery replacement and disposal

The 24 VDC control battery has a life expectancy of four years. It is recommended that the battery be replaced after four years or if the battery fails a battery test—whichever occurs first.

**Note:** Battery life is decreased at higher temperatures.

Dispose expired batteries in an environmentally responsible manner. Consult local regulations for proper battery disposal.

### Operation upon loss of AC power

The control is equipped with a 13 Amp-Hour 24 VDC lead acid battery for operation upon loss of AC power. The control maintains full operation from the battery for a period of time—24 hour maximum (20 °C).

In the event that the AC power has not returned within the times listed above, the control will disconnect the battery from the circuit.

**Note:** The control continuously monitors the battery voltage. To prevent battery damage, the control shuts down automatically upon detection of low battery voltage (below 22 VDC) for 60 seconds.

Control programming settings and parameters—including event recorder—are stored in non-volatile memory and retained upon loss of control power. The time/date clock will continue to operate for approximately 30 days after loss of control power.

## IMPORTANT

If the the control shuts down due to low battery voltage before AC power is restored, and the connected energized recloser is CLOSED, it will only TRIP and LOCKOUT via front panel pushbutton command.

A control that has shut down due to low battery voltage before AC power is restored will have a blank LCD display (no text message shown) and none of the LEDs will be illuminated.

Phase B (Ø) is the factory default phase. Unless changed by the user, the B PHASE VOLTAGE red LED illuminates indicating AC is the operating power. If BØ (or the user-indicated phase) loses AC power for more than ten seconds, the ALARM red indicator LED will illuminate. The ALARM log on the LCD Display will indicate NO AC PRESENT and the CONTROL OK LED will not be illuminated.

The control clock may require resetting if the operating power has been disconnected for more than thirty days. Refer to the *Form 6 NX-T Programming Guide* for information on setting the control clock.



**Figure 2. Form 6 NX-T recloser control is accessible from both the front and back of the cabinet**

## Form 6 NX-T control description

### Description

The Form 6 NX-T control is designed for use with these reclosers to provide protection, metering, and automation of distribution feeders in substation and line applications:

- NOVA NX-T

The Form 6 NX-T control operates the individual reclosers representing phases A, B, and C.

**Note:** Phase A, B, and C sequence positions are independent of each other.

The Form 6 NX-T control uses three modes of operation. All modes are configured through the ProView user interface software.

Three-phase trip, Three-phase lockout (ganged)  
Single-phase trip, Three-phase lockout  
Single-phase trip, Single-phase lockout

The Form 6 NX-T recloser control includes extensive system protection functionality, including phase, ground, and negative sequence overcurrent protection, over/under frequency, and voltage protection, directionality, sensitive ground fault, and sync check.

Analysis tools include fault locating, event recording, TCC Editor II, Idea Workbench, and oscillography functions, including oscillography replay.

Metering functions include demand and instantaneous current on a per-phase basis, instantaneous voltage and power factor on a per-phase basis, and power (real, reactive, apparent) on a per phase or total basis. Symmetrical components for both voltage and current are displayed along with kilowatt-hours for energy metering. Harmonics from the 2<sup>nd</sup> to the 15<sup>th</sup> harmonic are also included.

The front panel LCD display is used to configure the operating settings for the control. It is also used to display metering, counter information, control parameters, alarms, and provide diagnostic information.

Control parameters can also be programmed via a personal computer connected to the control through the front panel RS-232 port. Control programming, interrogation, and operations are performed with Form 6 ProView interface software on a personal computer.

The ProView interface program software includes additional functions used to create and graphically display Time Current Curves and provides the Idea Workbench for configuring user-selected inputs and outputs, configurable event and alarm data, and selectable communication points for serial communication.

The control operates on 50 and 60 Hz systems.

The control can be configured, by the factory or by the user, for a wide variety of applications. If user requirements change, the control functions can be modified to meet the new requirements.

The control is accessible from both the front and back of the cabinet (**Figure 2**).

### Theory of operation

A functional block diagram of the Form 6 NX-T control is shown in **Figure 3**. Current sensing is provided by three current transformers located in the recloser and interfaced to the Form 6 NX-T recloser control as follows:

- NOVA NX-T: via the pole mount frame's integrated junction box and control cable

This cable also supplies Trip, Close, and Recloser status, and connects to the Recloser Interface (RIF) module to provide isolation for reliable operation. Voltages for metering are connected to the analog input module through terminal block TB8.

Line current flowing through the recloser is converted by the CPU module to a digital signal suitable for metering and fault current calculations. Data sampling occurs at a rate of 64 times per cycle. The CPU contains a data acquisition section that uses the acquired samples to compute the fundamental currents and voltage for use in overcurrent, under/ overvoltage, and under/overfrequency protection, as well as currents and voltages for metering functions. The current for overcurrent protection is calculated on a sub-cycle basis; it includes only the fundamental and DC component.

When the phase or ground current exceeds its programmed minimum-trip value and associated time-current-curve (TCC) timing, the control initiates the programmed sequence of recloser tripping and reclosing operations via the CPU and RIF modules. If the fault is temporary, the control ceases to command recloser operations after a successful reclose, and the control resets to the start of its operating sequence after a preset time delay. If the fault is permanent, the control performs its complete programmed sequence of reclose commands and locks out with the recloser open. Once locked out, the control must be closed via the operator panel or SCADA communications. This resets the control to the start of the operating sequence.

### Phase operation

In *Three-Phase Trip, Three-Phase Lockout* (ganged) mode, all three phases simultaneously trip and close.

In *Single-Phase Trip, Three-Phase Lockout* and *Single-Phase Trip, Single-Phase Lockout* modes, each phase operates independently with protection parameters the same for all three phases.

In *Single-Phase Trip, Three-Phase Lockout* mode, all three phases trip to lockout when one phase sequences to lockout.

In *Single-Phase Trip, Single-Phase Lockout* mode, each phase independently sequences to lockout.

# Form 6 NX-T microprocessor-based pole-mount recloser control

## Ground operation

In *Three-Phase Trip, Three-Phase Lockout* (ganged) mode, all three phases trip and close.

In *Single-Phase Trip, Three-Phase Lockout* and *Single-Phase Trip, Single-Phase Lockout* modes, ground tripping is active when all three phases are closed. Ground trip is disabled during the reclose interval of any one phase.

For faults above the ground minimum trip value, and below the phase minimum trip value, all three phases trip on ground and advance to the next sequence position.

For faults above the phase and ground minimum trip value, the control trips on the phase(s) above phase minimum trip, operating on the phase or ground TCC, whichever is faster. Only tripped phases advance in sequence and are counted as phase operations.

## Phase/ground sequencing

Phase and ground share the same sequence position. As the position sequence advances, the phase and ground TCCs advance together to maintain proper coordination with upline and downline devices. This is applicable for temporary and permanent faults including faults on multiple phases.

## Control front panel

The Form 6 NX-T control front panel is illustrated in **Figure 4**.

The front panel is separated into two clearly identified, color-coded sections:

- The top portion of the front panel is used for programming the control and providing LED status indication.
- The lower portion of the front operating panel is used for operating the control and recloser.

The control includes a Power Save feature that will turn off the backlit LCD display and all LEDs (except Hot Line Tag) if no front panel keypad is pressed within ten minutes. Pressing the LAMP TEST key will re-activate the display and LEDs.

**Note:** The Power Save feature is a ProView interface software default setting. This feature can be disabled via the ProView interface software.

The control includes a Reset Menu feature that will cause the LCD display to revert to the Recloser Status menu after ten minutes of inactivity.

**Note:** The ten minute timer and Recloser Status menu is a ProView interface software default setting. The menu selection and timer can be changed via the ProView interface software.

## Front panel text messaging

The LCD messages are accessed from the front panel by following the Text Messages menu path. This menu displays any active user-configured text messages.

Up to fourteen user-configurable text messages can be programmed via the Idea Workbench. Refer to the *Form 6 NX-T Programming Guide* for information on programming the text messages.

These text messages appear on the front panel LCD and can be programmed to appear for alarm or other conditions.

Text messages displayed on the front panel are limited to four lines of 20 characters each (including spaces). Text messages can also be accessed by pressing the LAMP TEST one-touch analysis key on the front panel.

The default text message displays the mode of the triple-single configuration and the status of each phase.

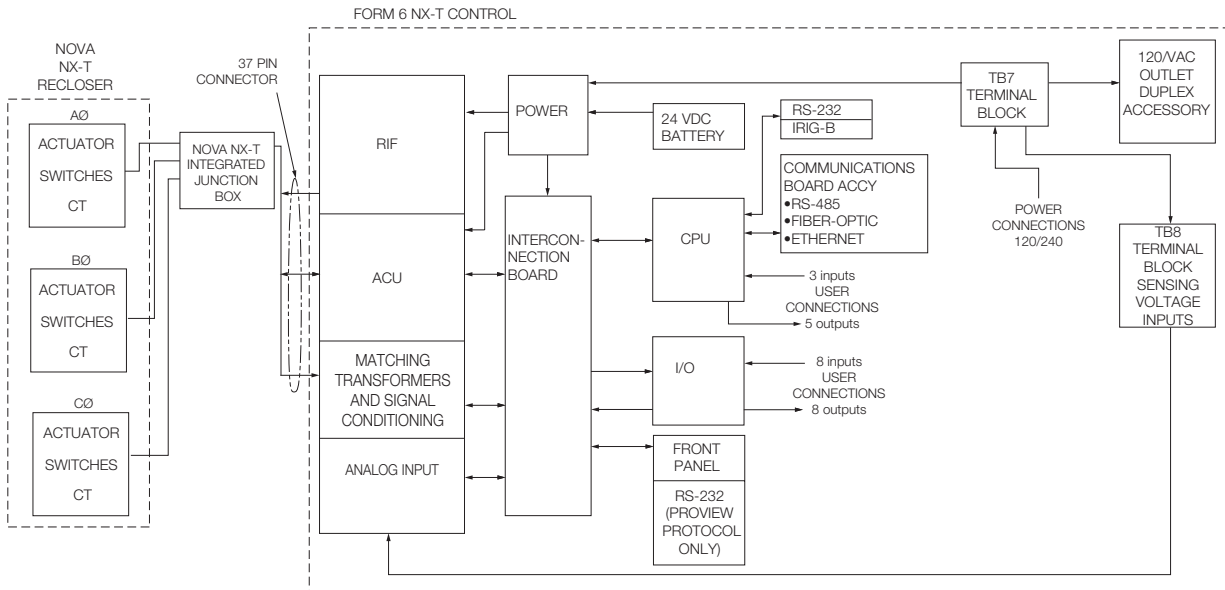

**Figure 3. Form 6 NX-T recloser control operational flow diagram**



### Programming panel

The Programming panel has the following sections:

#### One-touch analysis keys

There are eight analysis keys (Figure 5) that allow one-button access to a variety of control and monitoring functions that appear in the LCD display. Pressing these buttons causes the following information to display or function to occur:

**Note:** When pressing a membrane pushbutton, always press and hold for 0.5 seconds to ensure the button press is recognized by the device.

**METERING:** Displays the systems instantaneous metering values for current and voltage on the LCD display.

**RESET TARGETS:** Resets the fault target indicators on the operator panel.

**EVENTS:** Displays the last 25 events from the Sequence of Events log.

**LAMP TEST:** All operator panel LEDs are illuminated for verification of proper connection and operating status of all indicator lights. The status of all three phases will appear in the LCD display. All status indicators will then return to their previous state. While in the LAMP TEST mode, the control response to operator panel keys is disabled, except for the TRIP (LOCKOUT), CLOSE, and HOT LINE TAG switches.

**SETTINGS:** Displays recloser settings on the LCD display.

**OPER COUNTER:** Displays the total number of trip operations and target counters for each A, B, and C Phase; Ground, and Sensitive Ground on the LCD display.

**ALARMS:** Provides status information on the LCD display for all recloser alarms.

**CHANGE:** Allows the user to change the state of the control functions on the operator panel function keys.

**Note:** The CHANGE mode is a ten second period in which one function setting can be changed. If no change is made in that time, the control returns to the current setting.

#### LCD display

The LCD Display is a backlit 4-line, 20-character display that provides extensive distribution system, recloser, and control status information via the navigation keypads (Figure 5).

**Note:** The LCD display panel contrast is field-adjustable to allow for various mounting heights and applications. Press the MENU key and then press the (+) or (-) key to increase or decrease the contrast.

The four LCD navigation buttons are as follows:

MENU: Identifies the LCD Display menu options.

ENTER: Selects a menu option.

+: Increases value selection.

-: Decreases value selection.

The four LCD menu function keys activate specific menu commands. When a command appears in the LCD display directly above one of the four LCD menu function keys, the user can press the key to accept/select the command.

The four LCD menu function keys are as follows:

F1 F2 F3 F4

The four cursor movement arrows allow movement in the following directions:

◀ Moves the cursor left.

➤ Moves the cursor right.

▲ Moves the cursor up one line.

▼ Moves the cursor down one line.

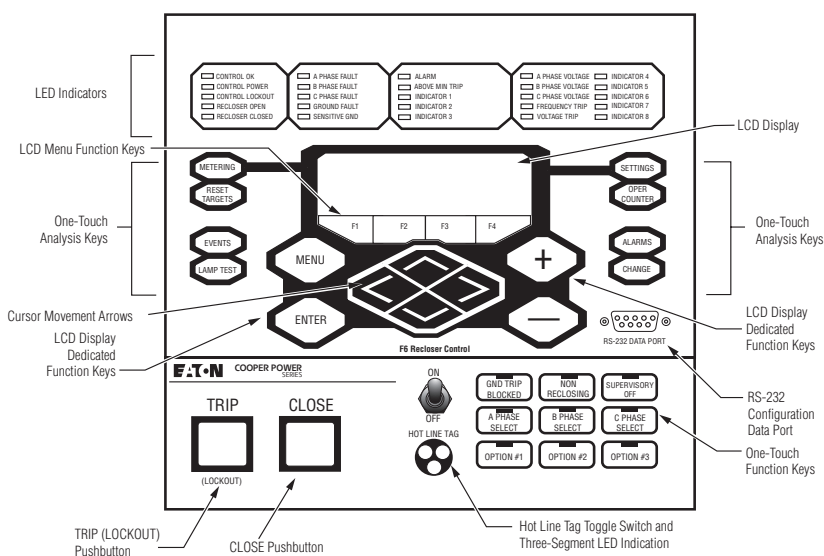

Figure 4. Form 6 NX-T control front panel

# Form 6 NX-T microprocessor-based pole-mount recloser control

## Status indicator LEDs

The status indicator LEDs in the Programming section of the Operator Panel give instant information on the control and recloser status. The Form 6 NX-T status indicator LEDs are illustrated in **Figure 6**.

All of the default status indicators LEDs (except for CONTROL OK, CONTROL POWER, and ALARM) can be reconfigured via the Idea Workbench. Refer to the *Form 6 NX-T Programming Guide* for additional information.

The label inserts can be user-customized. Refer to the **Using removable inserts** section of this manual for additional information.

**CONTROL OK:** The green LED indicates the control is operating normally and not in an alarm state.

The CONTROL OK LED will not be illuminated during these alarms (indicated by the red ALARM LED and displayed in the alarm status log):

- **Battery Alarm:** This alarm indicates battery voltage is low or the battery failed an operator-initiated manual test.
- **RAM Failure:** This alarm indicates a failed RAM memory test.
- **ROM Failure:** This alarm indicates a failed ROM memory test.
- **No AC Present:** This alarm indicates AC power was unavailable for 10 continuous seconds. This alarm resets when AC power is restored.
- **Power Supply Malfunction:** This alarm indicates internal control operation power was outside of its operating tolerance for more than 20 seconds. This alarm resets when the internal control operation power returns to operation within its normal tolerances.
- **RIF Comm Failure:** This alarm indicates a loss of communication from the RIF (Recloser Interface) circuit board to the main CPU circuit board. This alarm resets if communication is re-established.

**CONTROL POWER:** The green LED indicates there is adequate VTC voltage to trip the recloser. This LED does not indicate the presence of AC or battery power.

**CONTROL LOCKOUT:** The steady green LED indicates the control for all three phases is in a locked out state, i.e. a reclosing sequence is not in progress on any phase. In Single-Phase Trip/Single-Phase Lockout mode, the blinking green LED may indicate that the control for one or two phases is in a locked-out state, i.e. a reclosing sequence is not in progress on those one or two phases. This LED (blinking or steady) does not indicate that any phase is open.

**RECLOSER OPEN:** The steady green LED indicates all three phases are in the open position. In Single-Phase Trip/Single-Phase Lockout and during a sequence in Single-Phase Trip/Three-Phase Lockout mode the blinking green LED indicates one or two phases are in the open position.

**RECLOSER CLOSED:** The steady red LED indicates all three phases are in the closed position. In Single-Phase Trip/Single-Phase Lockout and during a sequence in Single-Phase Trip/Three-Phase Lockout mode the blinking red LED indicates one or two phases are in the closed position.

**Note:** There are several conditions that will cause the alternate blinking of the CONTROL LOCKOUT, RECLOSER OPEN, and RECLOSER CLOSED LEDs: Failure to Trip, Failure to Close, Interrupter Malfunction, and 52a/b Disagreement.

The LED blinking pattern for these conditions is the CONTROL LOCKOUT green LED and RECLOSER CLOSED red LED alternating with the RECLOSER OPEN green LED. The red ALARM LED will also be illuminated.

This LED blinking pattern is different than the continuous blinking of all three LEDs that occurs when all three reclosers do not have the same status, i.e. OPEN or CLOSED.

To determine the actual status of each recloser (phase), refer to the Form 6 NX-T control front panel RECLOSER STATUS LCD menu display.

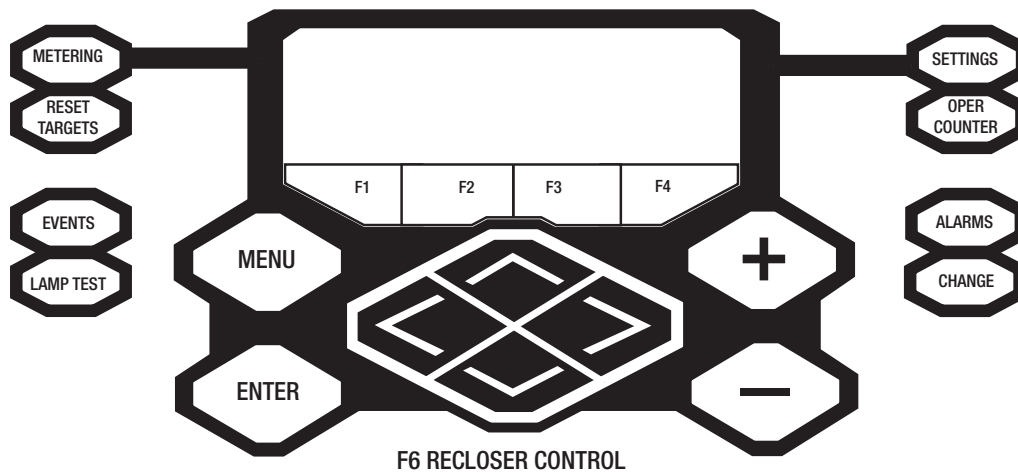

**Figure 5. Analysis keys, LCD display, LCD menu function keys, and cursor movement arrows**

A PHASE FAULT, B PHASE FAULT, C PHASE FAULT: The red LEDs indicate A, B, and/or C phase current was either the maximum phase current or within 20% of the maximum when a trip signal was issued.

GROUND FAULT, SENSITIVE GROUND FAULT: The red LEDs indicate that a Ground and/or Sensitive Earth Fault tripping function was asserted at the time the trip signal was asserted.

ALARM: The red LED indicates an alarm has been issued. Review the alarm status and log on the LCD display for the specific alarm.

ABOVE MINIMUM TRIP: The red LED indicates the current exceeds the level set for minimum trip.

FREQUENCY TRIP: Indicates the recloser tripped due to an under or over frequency condition.

VOLTAGE TRIP: Indicates the recloser tripped due to an under or over voltage condition.

A PHASE VOLTAGE, B PHASE VOLTAGE, C PHASE VOLTAGE: Indicates a presence of voltage on the respective phases. The Single-Phase Undervoltage Pickup setting controls the voltage indication for the front panel LEDs as defined in the Voltage setting dialog box for the active setting profile. Refer to **Settings - Voltage** in **Schemes** section of the *Form 6 NX-T Programming Guide*.

INDICATOR 1, INDICATOR 2, INDICATOR 3, INDICATOR 4, INDICATOR 5, INDICATOR 6, INDICATOR 7, INDICATOR 8: Customizable LEDs that are used with functions programmed through the Idea Workbench. The LED indicators do not have active default values. The LEDs are illuminated when the status configured via the Idea Workbench is present.

### Operating panel

The Operating section includes the following sections:

#### RS-232 Configuration Data Port

The RS-232 connector (shown in **Figure 4**) on the front operating panel allows direct connection to a personal computer without any special cables or connectors. This port is used only for configuring the control with ProView application software. All settings, metering, events, and oscillography data are available from this port. The port is Data Communication Equipment (DCE) wired for direct connection to a personal computer.

#### HOT LINE TAG ON/OFF toggle switch and led indicator

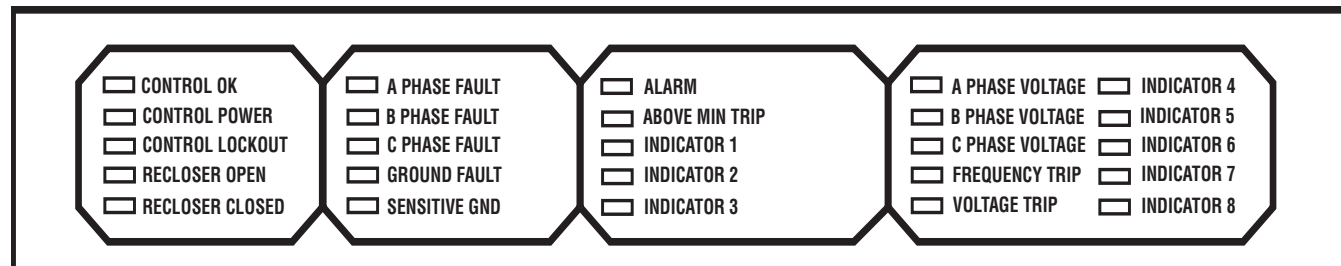

Figure 6. Form 6 NX-T control status indicator LEDs

### ⚠ WARNING

**Hazardous voltage. Do not use Hot Line Tag as a substitute for a visible disconnect. Always establish a visible disconnect prior to performing any work requiring a de-energized line. Failure to comply may cause death, severe personal injury, or equipment damage.**

T276.0

Hot Line Tag is provided for live-line work applications. All closing operations are disabled when the Hot Line Tag feature is activated.

### IMPORTANT

Hot Line Tag activation does not cause the recloser to trip open. It only prevents the recloser from closing.

### IMPORTANT

Hot Line Tag is intended solely for live-line work applications, such as maintenance, repairs or improvements to the distribution system, that occur while the line remains energized.

Hot Line Tag prevents all closing attempts from the control and shifts protection to one trip-to-lockout on the composite curve of the Hot Line Tag definite time and the TCC1 curve (whichever is faster).

Hot Line Tag takes precedence over Cold Load Pickup, Non-Reclosing, and Fast Trips Disabled.

Hot Line Tag is activated from either the operator panel toggle switch, serial communications, or a discrete SCADA function. All sources must be off to de-activate Hot Line Tag.

To activate the function from the operator panel, flip toggle switch up to the ON position. See **Figure 7**. The LED indicator illuminates when the function is active.

The Hot Line Tag function may only be reset by the source which initiates it. For example, if Hot Line Tag is activated at the operator panel, the reset function is only possible at the operator panel, and not via SCADA command.

### IMPORTANT

If the power save feature is enabled (default), and more than ten minutes elapses since the last panel operation, all the LEDs, except HOT LINE TAG (if active), will turn off.

# Form 6 NX-T microprocessor-based pole-mount recloser control

## TRIP (Lockout) Pushbutton

The TRIP pushbutton (Figure 7) provides front-panel access to trip (lockout) the recloser. When pressed, the TRIP pushbutton opens the recloser and locks out the control.

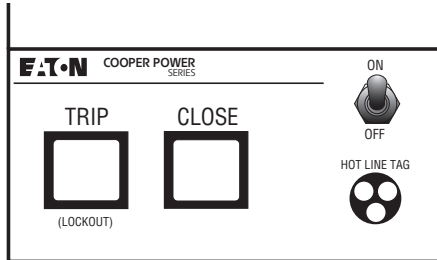

**Figure 7. TRIP (Lockout) pushbutton; CLOSE pushbutton; Hot Line Tag switch and Hot Line Tag red indicator LEDs**

**Note:** In the event of main microprocessor failure, the trip circuit can operate independent of the main microprocessor.

## CLOSE Pushbutton

When pressed, the CLOSE pushbutton (Figure 7) returns the control to the initial or home sequence position, closing the recloser. The control is ready for the start of a new trip/close sequence.

**Note:** The Close Malfunction alarm must be reset before Closing will be allowed.

**Note:** Pressing the CLOSE pushbutton from the Lockout position initiates Cold Load Pickup (CLPU) protection, if the feature is enabled.

The user does have the ability to block COLD LOAD PICKUP through the LCD menu or by configuring one of the Option one-touch function keys via the Idea Workbench feature in ProView.

If the recloser is closed, pushing and holding the CLOSE pushbutton does not activate the Cold Load Pickup feature. See **Cold load pickup** in the **Control features** section of this manual.

## One-touch function keys

Quick access to frequently operated Form 6 NX-T control features is provided with nine function key pushbuttons on the control operator panel.

The Form 6 NX-T control operator panel one-touch function keys are illustrated in Figure 8.

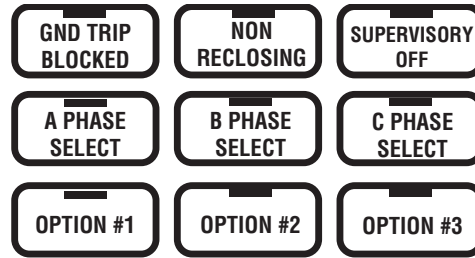

**Figure 8. Form 6 NX-T control operator panel one-touch function keys**

Red LEDs located on each function key indicate the status of the function, regardless of local or remote activation. For example, if Ground Trip Blocked is activated from a SCADA signal, the red indicator will illuminate even though it was not activated from the operator panel.

## Operator panel function key activation or de-activation

requires the operator to first press the CHANGE key to enter the CHANGE mode. A function must then be selected or de-selected within ten seconds to activate or de-activate the function. Once selected, the control returns to normal operation until prompted for another change request. This prevents accidental changing of functions or features.

**Note:** Only one function can be changed per each CHANGE mode activation.

## GND TRIP BLOCKED

The Ground Trip Blocked function blocks all ground sensing in the control for the active profile. This red indicator is illuminated when Ground Trip Block is activated from the serial port, I/O, the interface software, or locally (via the front panel) causing the control to block all ground sensing.

## NON RECLOSING

The control is operating in a non-reclosing mode when the NON RECLOSING red indicator is illuminated. Non-reclosing mode disables any automatic reclosing operations.

Non-reclosing does not alter the active TCC. Activation is possible from the SCADA port, I/O, the interface software, or locally (via the front panel).

## SUPERVISORY OFF

When the SUPERVISORY OFF red indicator is illuminated, supervisory commands are blocked. Supervisory functions through the back panel serial communication ports and the discrete I/O are blocked. Serial communications through the front panel RS-232 port remain active independent of the status of the SUPERVISORY OFF switch. Activation of this function key is restricted to the operator panel and is accomplished by pressing the CHANGE key and then pressing the SUPERVISORY OFF key. Operational data and metering information are available while the control is in the SUPERVISORY OFF position. The TRIP and CLOSE pushbuttons and Hot Line Tag are active independent of the SUPERVISORY OFF function.

## OPTION #1, OPTION #2, AND OPTION #3

The OPTION #1, OPTION #2, and OPTION #3 function keys must be programmed via the ProView Idea Workbench software. These options do not have active default values.

The OPTION LEDs are illuminated when the options configured via the Idea Workbench are selected. Refer to the *Form 6 NX-T Programming Guide* for additional information.

These OPTION keys provide a momentary signal. For instance, these keys can be programmed to toggle control status, protective functions, or a momentary input pulse.

A PHASE SELECT, B PHASE SELECT, C PHASE SELECT

The Form 6 NX-T control when in Single-Phase Trip/Single-Phase Lockout mode has phase selection keys available for the user to indicate only which phase of the triple-single recloser will operate when the manual TRIP (LOCKOUT) and CLOSE pushbuttons on the Form 6 NX-T operator panel are pressed. When the TRIP or CLOSE buttons are pressed, only the phases that are selected (LED on) will trip or close.

Manual operation of the yellow handles on the triple-single recloser is used to open and lockout the phases, and to disable the electrical and supervisory closing. The recloser mode of operation determines which phases open and close. The Form 6 NX-T control initiates the close signal.

 **WARNING**

**Hazardous voltage. Do not rely on the open position of the yellow operating handle; it does not ensure that the line has been de-energized. Always establish a visible disconnect. Failure to follow proper safety practices can result in contact with high voltage, which will cause death or severe personal injury.**

G116.0

**IMPORTANT**

Pushing the yellow operating handle to the CLOSE position **will not** close the recloser. All close operations are initiated by the Form 6 NX-T control.

**Three-phase trip – three-phase lockout (ganged)**

or

**Single-phase trip – three-phase lockout**

If the control is in Three-Phase Trip – Three-Phase Lockout (ganged) mode or Single-Phase Trip – Three-Phase Lockout mode, all three phases are permanently selected and the A PHASE SELECT, B PHASE SELECT, and C PHASE SELECT LEDs are illuminated.

When one phase is opened with the yellow operating handle, all three phases open and lockout. The RECLOSER OPEN and CONTROL LOCKOUT indicator LEDs illuminate on the control panel.

With the yellow operating handle of the appropriate phase in the CLOSE position, press the CLOSE pushbutton on the control operator panel. All three phases close and the RECLOSER CLOSED LED illuminates.

**Single-phase trip – single-phase lockout**

When in Single-Phase Trip – Single-Phase Lockout mode any combination of phases can be selected and the respective PHASE SELECT LED illuminates. Each selected phase must be closed individually.

When the selected phase is opened with the yellow operating handle, only that phase opens and locks out. The RECLOSER OPEN, RECLOSER CLOSED, and CONTROL LOCKOUT indicator LEDs blink on the control panel.

The default text message on the LCD displays the mode of the triple-single configuration and the status of each phase.

With the yellow operating handle of the selected phase in the CLOSE position, press the CLOSE pushbutton on the control panel. The phase closes and the RECLOSER CLOSED LED illuminates.

**IMPORTANT**

If the power save feature is enabled (default), and more than ten minutes elapses since the last panel operation, all the LEDs, except HOT LINE TAG (if active), will turn off. Verify the phase or phases you want activated are selected prior to pressing the TRIP or CLOSE button.

**Control features**

The Form 6 NX-T recloser control offers numerous standard features and accessories that allow the user the utmost flexibility applying the recloser control.

**Control security**

The Form 6 NX-T recloser control has multiple customer-programmable security codes to limit control programming and viewing function access to authorized personnel. The front panel Human-Machine Interface (HMI) includes a user-selected security code to access the settings. Plus, the ProView interface software has it's own security levels for multiple-user access.

Refer to the *Form 6 NX-T Programming Guide* for additional information.

**Protection profiles**

Four protection profiles capable of fully specifying control operation are standard in the control. Each protection profile includes the following as a minimum:

- Overcurrent Protection
- Over/Undervoltage Protection
- Over/Underfrequency Protection
- Directional Protection
- Hot Line Tag Functionality
- Sync Check
- Sensitive Earth Fault Protection
- Sequence Coordination
- Operation Settings

## Form 6 NX-T microprocessor-based pole-mount recloser control

### Time current curves

Time-current curves are available for numerous functions, including fast and delayed operations for phase, ground, and negative sequence protection. Each time-current is selected from a defined fifty curves which can be further customized by the user. The time-current curves are also selected from a graphical TCC Editor II to visualize any modifications prior to configuring the control.

The time-current curves include the following modifications for phase, ground, and negative sequence protection:

- Time Multiplier with a range of 0.1 to 25 in .1 increments.
- Time Adder with a range of 0 to 30 seconds in .01 second increments.
- Minimum Response Time with a range of 0.01 to 1 seconds in .001 second increments.
- High Current Trip multiplier with a range of 1 to 32 multipliers in increments of 0.1.
- High Current Trip Time Delay with a range of 0.01 to .150 second in .001 second increments.
- Time Dial Reset co-efficient with a range of .1 to 30 seconds in 1 second increments.

### Sequence coordination

Sequence Coordination eliminates nuisance tripping through trip coordination. It allows the control to step through selected operations in the operating sequence without tripping. The number of Sequence Coordination advances is programmable from one to three operations to provide trip coordination with a downline recloser. This feature is independently selectable for each protection profile.

### Cold load pickup

The control includes a Cold Load Pickup feature to prevent the control from tripping while energizing non-fault system loads. This feature has independently programmable minimum trip value time-current curve, reclose interval, and number of independent operations to lockout for each protection profile. Cold Load Pickup also includes TCC Multipliers, TCC Adders, Minimum Response Time, Time Dial Reset, and High Current Lockout. Also, direct values, not multiples of minimum trip, are provided for high current lockout.

### Fast trips disabled

The control includes a Fast Trips Disabled feature to modify protection, so that all trip operations use the programmed TCC2. This feature is independently selectable for each protection profile. All trip operations will time on TCC2. Typically, TCC1 is fast and TCC2 is delayed. So, as an example, the control will change it's sequence from 2 fast and 2 delayed operations to 2 operations on TCC2 when Fast Trips Disabled is active.

### High current lockout

The High Current Lockout feature will automatically lockout the control on the selected operation when current exceeds a programmable level. The active trip numbers for the lockout is selectable for phase, ground, and negative sequence. This feature is independently selectable for each protection profile.

### Sensitive ground/earth fault operation

The control has a Sensitive Ground/Earth Fault Trip feature that provides tripping of the recloser after a programmable, definite time for ground currents below normal ground minimum trip levels. The feature has programmable operations to lockout and reclose intervals independent of the ground settings. This feature is independently selectable for each protection profile.

### Thermostatically controlled heater

The control has a standard 15 Watt thermostatically controlled heater (ON 70 °F, OFF 85 °F) for humidity control and voltage input independent. The heater is powered from the power supply board.

### Metering

The control provides instantaneous and/or demand metering with programmable integration intervals for the following functions:

- Real and reactive power for each phase and total, including directional, on an individual phase basis.
- Demand currents on a per phase basis.
- Instantaneous currents, including ground current.
- Instantaneous voltage on a per phase basis.
- Instantaneous frequency.
- Positive, negative, and zero sequence voltages.
- Instantaneous power factor on a per phase basis.
- Metering settings to include demand interval, and alarm thresholds for current, single-phase kW, three-phase kW, single-phase kvar, and three-phase kvar.

### Event recorder

The Form 6 NX-T control contains capabilities to perform Sequence of Events time-stamping for up to 69 event types. Sixteen additional inputs can be user-defined through the Idea Workbench.

Factory-defined event types include:

- Overcurrent Protection Trip
- External Trip
- Non-Reclose Trip
- External Close
- Lockout
- Reset

The Event Recorder maintains a minimum of 90 event records. The last 25 events are viewable on the front panel LCD display. Refer to the *Form 6 NX-T Programming Guide* for additional information.

### Recloser duty monitor

The Form 6 NX-T recloser control software is equipped with a Recloser Interrupting Duty Monitor. The Duty Monitor accumulates the summation of 11.5 for all interrupted currents on each interrupter. This feature permits programmable entries to preset the duty of an existing recloser. The recloser duty monitor displays interrupting duty in percent of duty used. If the duty cycle monitor exceeds 100%, the recloser should be examined for maintenance.

### Discrete SCADA communications

The control provides five configurable output status contacts and three configurable input control contacts as standard. Each status contact is configurable using graphical interface software to combine status functionality along with Boolean algebra. Default output status contacts are: AØ Lockout, AØ Recloser Open, AØ Recloser Closed, Ground Trip Block, and Hot Line Tag. One output status contact is a solid state output (SS1) with a pickup time no longer than two milliseconds.

The control also provides a minimum of three configurable input control contacts. Each control contact is configurable using a graphical interface software. Contacts accept a whetting voltage range of 12 – 250 VDC, 120/240 VAC. Each digital input is configured for either a momentary, maintained, or maintained with precedence contact. Default input control contacts are: Supervisory Trip and Lockout, Supervisory Close, and Remote Trip and Lockout.

A Discrete Interface Board is also available as an accessory to provide an additional eight output status contacts and eight input control contacts. The expansion I/O board is completely user-configurable.

### TCC Editor II

Coordination and actual time current modifications are available with a graphic interactive TCC Editor or similar graphical software.

The TCC Editor II includes a complete database of standard recloser industry time current curves (TCC), both ANSI and IEC types, along with the ability to customize the TCCs with multipliers, constant time adders, or minimum response time adders. Also, the user is able to derive their own specific TCC through data point entry. Each modified time current curve can be identified with a user-customized name and is selectable for configuring the control. The grid and format for presenting the TCCs has a user-adjustable scale, including the option of presenting multiple TCCs in various user-configured colors.

### Oscillography

Oscillography is provided to present current and voltage waveforms, along with protection element and recloser response status changes. Filtered and unfiltered data are provided for viewing.

The recorded values are super-imposed on the protection scheme, and the state or value at any point in the scheme is displayed. The user has the capability to move through the event and watch the response of every function. All analog signals, digital inputs, and contact outputs are monitored. Analog oscillography is displayed at 16 samples per cycle.

Oscillographic data is recorded to analyze multiple events during a permanent fault or other event type. The oscillographic data shows two cycles before the trigger point and eight cycles after the trigger point (default).

**Note:** The configuration settings are programmable.

Oscillography automatically initiates trigger points for the following functions:

- Above Minimum Trip for Phase, Ground, and Sensitive Ground Fault
- Single- and Three-Phase Overvoltage
- Single- and Three-Phase Undervoltage
- Over- and Underfrequency
- Trip Signal Issued
- Close Signal Issued

### Removable inserts

Removable inserts are included with the control design for customization of specific protection requirements. Inserts are available for the status indicator LEDs, the operator panel function keys, and the analysis keys. The removable inserts are designed for use without adhesives, labelmakers, or temporary labels. Refer to the **Using removable inserts** section in this manual for more information.

An electronic label template is included on the ProView application software CD and can be accessed through the following default address:

C:\Program Files\Cooper\ProviewXX\Form 6\Form 6 Inserts.doc

### Idea workbench

The Idea Workbench provides access to various inputs, intermediate variables, and internal Form 6 alarms, status, and targets to allow user-customization of the Form 6 NX-T recloser control to meet specific and unique applications. The Idea Workbench also gives the user the ability to perform logical functions with these variables by using a simple graphical user interface. Use of the Idea Workbench is not a requirement for operation.

Refer to the *Form 6 NX-T Programming Guide* for additional Idea Workbench information.

### Over/underfrequency protection

The control includes two-stage operation for both underfrequency and overfrequency protection. A fixed time delay ranging from 0 to 100 seconds in .001 second increments is available for both over and underfrequency.

## Form 6 NX-T microprocessor-based pole-mount recloser control

A frequency restoration function, enabled or disabled by the user, is provided to allow the recloser to automatically close should frequency return to within configured settings for a user-settable time. Over/Underfrequency Protection is included as part of each protection profile.

### Over/undervoltage protection

The control includes single-phase and three-phase under voltage tripping. The control also includes three-phase overvoltage tripping. Both over and undervoltage functions include a single-phase and three-phase pick-up setting; a single-phase and three-phase time delay setting ranging from 0 – 100 seconds.

### Directional

Directional functionality is included to maintain system coordination from multiple sources, as well as circuit reconfiguration for each profile. Directional applies to phase, ground, and negative sequence protection, selected independently. A maximum torque angle has a range of 0 – 90 degrees.

### Fault location

The control includes an impedance-based fault locator based upon the Takagi algorithm<sup>1</sup>. Load-compensated impedance calculation is used for calculating the distance. Positive and zero sequence is configured in ohms, and the fault locator line length is configured in kilometers/miles.

<sup>1</sup>T. Takagi, Y. Yamakoshi, J. Baba, K. Uemura, T. Sakaguchi, "A New Algorithm of an Accurate Fault Location for EHV/UHV Transmission Lines: Part I - Fourier Transformation Method," *IEEE Trans. on PAS*, Vol. PAS-100, No. 3, March 1981, pp 1316-1323.

### Sync check

Sync Check is a permissive system used to qualify any close signal to the mechanism when enabled via the sync check settings. Sync check allows for closing for any combination of dead/live bus/line, and to perform anticipatory closing for a live bus/live line condition by calculating slip and anticipating the mechanism closing delay. In addition to the anticipatory close calculation, the sync check system performs verification of line and bus voltage magnitudes and frequencies to determine that they are within pre-determined ranges, and that the angular difference between the two systems is also within the pre-determined range. For a live/live close, where there is no slip between the systems, the sync check system allows permissive closing after the two systems are within frequency and voltage limits, and the angular difference between the systems has been within the allowable limits for a pre-determined time.

Sync Check functionality includes the following applications: Hot Line/Hot Bus Closing; Dead Line/Hot Bus Closing; Hot Line/Dead Bus Closing; and Dead Line/Dead Bus Closing.

Sync Check Parameters include the following configurable settings: Voltage Angle; Mechanism Operating Delay; Static Angle Delay; Dead Threshold; Live Threshold; Positive Sequence Dead Threshold; Upper Voltage Limit; Lower Voltage Limit; Lower Frequency Limit; Upper Frequency Limit; and Fail to Close Timer.

### Data profiler

A fully-configurable data profiler is available which allows the user to collect information by sampling data at selectable intervals. These time-stamped values can then be viewed to determine weekly load profiles, daily harmonic disturbances or hourly voltage fluctuations. The number of days of information the data profiler can provide depends upon configuration parameters.

Refer to the *Form 6 NX-T Control Programming Guide* for additional information.

### Manual close delay

Manual Close Delay provides a delay from the time that the manual CLOSE button is pushed to the time the manual close operation is performed.

The delay is programmable from 0 to 60 seconds in 1 second increments. A programmed delay value can be overridden for immediate closing by pressing the CLOSE button a second time.

An active Manual Close Delay can be canceled by pressing the TRIP/LOCKOUT button.

The default setting has the feature disabled (0 seconds). A countdown on the front panel LCD screen indicates Manual Close Delay is active.

## Communications

### Communication ports

The Form 6 NX-T control has two back panel communication ports and a front panel configuration data port.

The front panel configuration data port is described in the **Operating panel** section of this manual.

There is one standard 9-pin RS-232 and one optional communication port (RS-485, serial fiber, Ethernet wire or fiber or both) on the back operator panel, as well as a standard IRIG-B port for user time-syncing. See **Figure 9**.

### Communication protocols

Three communication protocols are available for the Form 6 NX-T recloser control:

- Modbus
- DNP3
- 2179

One communication protocol can be selected for either the back panel RS-232 or the optional communication port.

All three protocols are selected and configured by the user with the ProView Communications Workbench application software.

### Ethernet communications

- ProView over TCP/IP
- DNP3 over TCP/IP



## Form 6 NX-T microprocessor-based pole-mount recloser control

Ethernet connection allows for network application of the Form 6 NX-T control for both DNP3 and ProView protocols. In addition, the front panel data port can simultaneously communicate ProView to the PC.

Ethernet configuration is accomplished via ProView interface software. Refer to the *Form 6 NX-T Programming Guide, Section 4: Schemes, Communicating with the Form 6 Control*, for Ethernet Configuration information.

When a communication protocol is selected for the optional communication boards (serial fiber or the RS-485 serial port), the RS-232 serial port is defaulted to ProView interface software protocol.

DNP3 is factory-defaulted to the RS-232 port.

When a communication protocol is selected for the RS-232 serial port, the optional RS-485 or serial fiber optic board is not active.

The RS-485 or fiber optic serial ports do not support ProView interface software protocol.

The user can simultaneously communicate to the Form 6 NX-T control using both the front panel data port and the appropriate back panel serial communication port (provided the back panel RS-232 port or the Ethernet optional communications board is not configured to be ProView protocol).

### Control information

Control information includes firmware identification by catalog number and name, date code, and ProView release number. Control information is available through the Settings menu on the front panel (**Figure 4**).

### Control back panel

The control back panel is easily accessible through the back door of the control cabinet (**Figure 2**) with readily identifiable serial ports and connections (**Figure 9**).

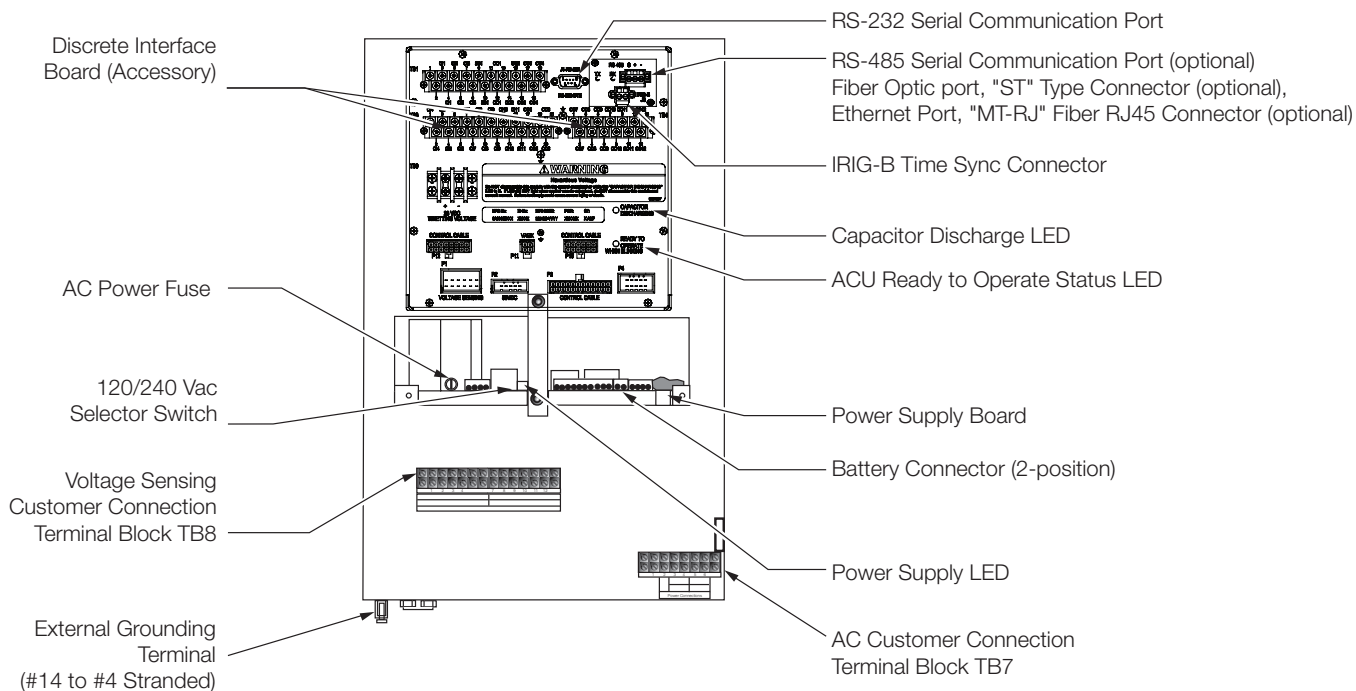

**Figure 9. Form 6 NX-T recloser control back panel terminal block and communication port identification**

## Installation procedure

### Initial programming prior to installation

#### CAUTION

**Equipment misoperation. Do not connect this control to an energized recloser until all control settings have been properly programmed and verified. Refer to the programming information for this control. Failure to comply can result in control and recloser misoperation, equipment damage, and personal injury.**

G110.3

#### NOTICE

**Equipment misoperation. Check minimum trip values prior to changing an alternate profile. Failure to do so may cause misoperation of the recloser under load conditions.**

T280.1

#### IMPORTANT

Program all protection profiles. Unused alternate profiles should be programmed with the same settings as one of the applicable profiles. Default settings on unused alternate profiles can cause unnecessary outages if they are below normal system requirements.

The control must be programmed with all necessary operating settings, all alternate profiles, and parameters prior to operation with an energized recloser.

**Note:** Initial programming of the control is the responsibility of a qualified technician or engineer familiar with control functions and programming parameters required for the specific recloser installation.

The control must be programmed with the Form 6 ProView interface software. Refer to the *Form 6 NX-T Programming Guide* for additional information.

**Note:** The Pole Mounted Control checkbox in the ProView System Configuration screen must be selected for all Form 6 pole-mount controls. This includes both pole and substation applications.

### Control/recloser compatibility

The Form 6 NX-T pole-mount recloser control is only compatible with the NOVA NX-T recloser. Refer to the appropriate recloser instructions for additional information:

- *Service Information MN280087EN NOVA NX-T Recloser Installation and Operation Instructions*

### Duty cycle monitor

The Duty Cycle Monitor provides the following duty cycle information:

- Measures and records duty for each individual phase in non-volatile memory.

- The recloser duty is measured and stored on the basis of  $Current^{1.5} \times Number\ of\ Operations\ for\ Each\ Phase$  (ANSI C37.61).
- Readout is based on a percentage of total duty cycle used for each phase.
- Duty record can be adjusted or reset if recloser is changed-out, serviced, etc.

Using **Table 1**, select the appropriate recloser interrupting duty cycle factor and enter that value via the ProView interface software.

**Table 1. Duty cycle factor**

Recloser Type	Interrupting Rating (rms sym Amps)	100% Duty Cycle Factor*
NOVA NX-T-12	12,500	1111
NOVA NX-T-16	16,000	1608

\* Duty Cycle Factor is Value x 10<sup>5</sup>

### Control cable

#### WARNING

**Hazardous voltage. Recloser and control must be solidly grounded. Follow all approved procedures and safety practices when grounding this equipment. Improper grounding can result in contact with high voltage, which will cause death or severe personal injury.**

G115.1

#### WARNING

**Hazardous voltage. Do not touch the pins inside the control cable connector. Pins could be energized if a trip or close signal is issued. Failure to comply could cause severe injury or death.**

**Note:** Control is interlocked such that during normal operation, voltage cannot appear unless correct 52a/b status is reported by the recloser.

- The maximum control cable length between the Form 6 NX-T control and the frame-integrated junction box is 95 feet.

**Note:** The control cable must be supported along its length to prevent repeated movement due to wind or other outside forces which can damage the cable.

## IMPORTANT

All external inputs to the Form 6 recloser control must be routed within 8 inches of their corresponding ground. During a surge, a potential of approximately 1.5 kV per foot can develop in the conductors. Differences between conductor and ground path lengths can add additional stress to the control components in the event of a power surge.

### Integrated junction box

The NOVA NX-T pole-mount frame incorporates the junction box as part of the frame construction. This unique feature eliminates the need for a separate junction box, and it simplifies construction and installation time. The junction box is fully vented around the perimeter of its bottom panel, allowing moisture to easily drain out without pooling within the enclosure. Each NOVA NX-T recloser junction box cable and the single control cable utilizes Eaton's MIL-DTL-38999 Series IV connector and is completely sealed against moisture. There are no terminal blocks, heaters, or exposed bare wires required within the junction box enclosure. The unique design of Eaton's MIL-DTL-38999 Series IV connector interface will prevent moisture from entering the connector system.

The integrated junction box features a sloped roof to deflect water, snow, sleet, and other environmental elements off the frame. This also shelters all the cable connections at the junction box receptacle panel.

### Mounting the control

#### WARNING

**This equipment is not intended to protect human life. Follow all locally approved procedures and safety practices when installing or operating this equipment. Failure to comply may result in death, severe personal injury and equipment damage.**

G102.1

#### WARNING

**Falling equipment. Use the lifting lugs provided and follow all locally approved safety practices when lifting and mounting the equipment. Lift the unit smoothly and do not allow the unit to shift. Improper lifting can result in severe personal injury, death, and/or equipment damage.**

G106.3

Mount the Form 6 NX-T recloser control in a convenient, accessible location. Mounting dimensions are provided in **Figure 11**.

**Note:** Unless otherwise specified, dimensions shown in inches (mm).

A hole and keyway in the control mounting bracket accommodates a 5/8 inch (15.9 mm) bolt.

### Locking the control

The handles on the Form 6 NX-T control cabinet are able to accept a padlock to prevent unauthorized access. For cabinets with the quarter-turn latch, the top handle has two locking holes provided depending on the diameter of the lock shackle being used. Refer to **Figure 11**.

- Use the smaller hole for shackle diameters of 0.177 – 0.295 inch.
- Use the larger hole for shackle diameters of 0.295 – 0.394 inch.

**Note:** DO NOT use a smaller shackle (0.177 – 0.295 inch) in the larger diameter hole as it will NOT LOCK the cabinet.

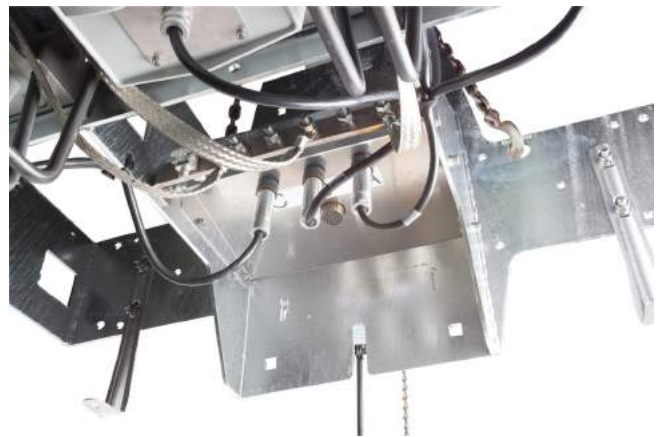

**Figure 10.** NOVA NX-T reclosers are connected to the Form 6 NX-T control through the integrated junction box

Form 6 NX-T microprocessor-based pole-mount recloser control

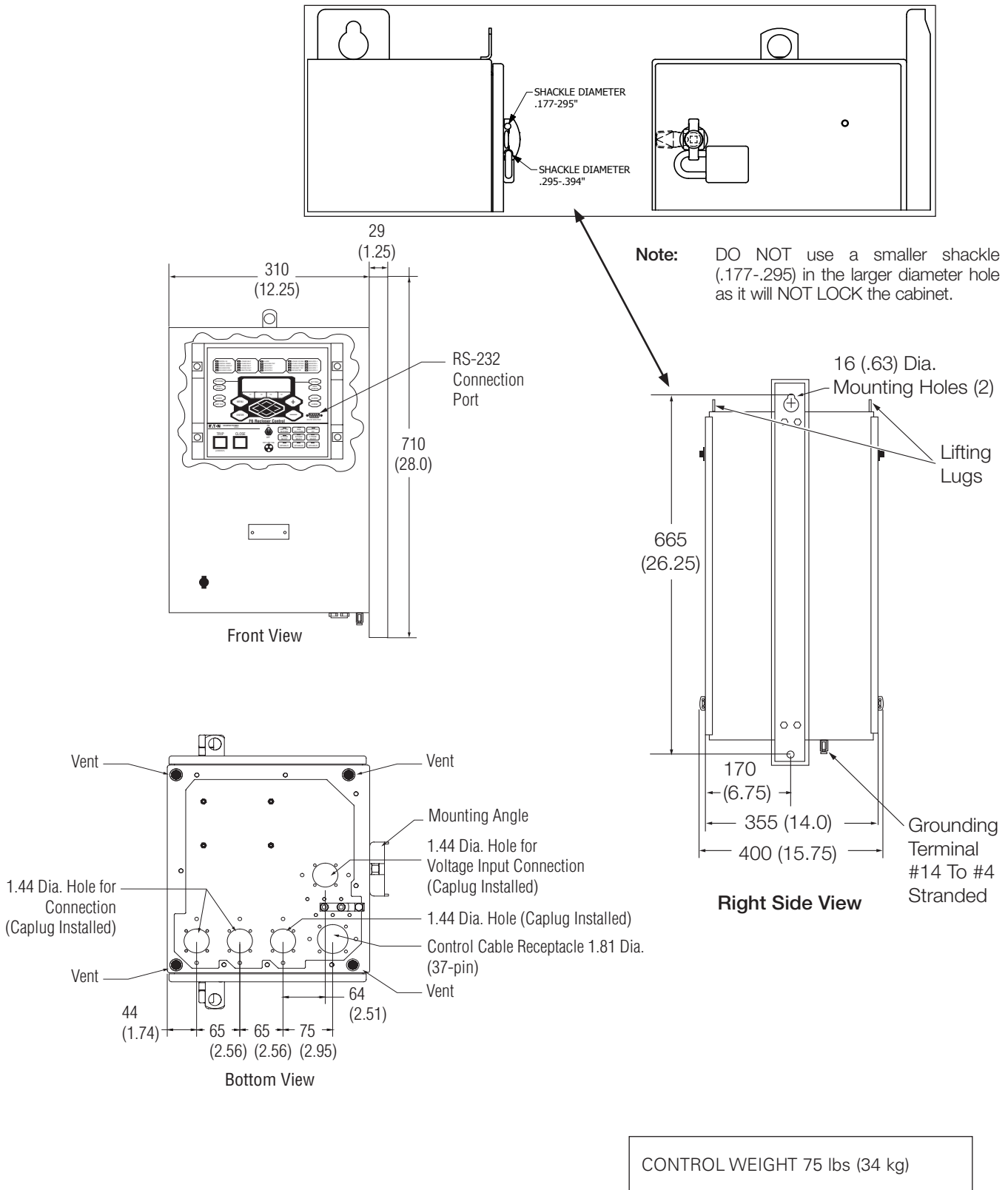

Figure 11. Form 6 NX-T pole-mount recloser control weight, dimensions, and pad-lock shackle diameters

**Grounding the control****⚠ WARNING**

**Hazardous voltage. Recloser and control must be solidly grounded. Follow all locally approved procedures and safety practices when grounding this equipment. Improper grounding can result in contact with high voltage, which will cause death or severe personal injury.**

G115.1

The control cabinet must be grounded. A grounding connector on the underside of the cabinet will accommodate No. 14 solid through No. 4 stranded conductors.

Suggested methods for grounding the control and recloser are shown in **Figure 12**, **Figure 13**, and **Figure 14**.

**Figure 12** illustrates grounding methods for 3-wire ungrounded and 4-wire multi-grounded systems with local supply voltage transformer.

**Figure 13** illustrates grounding methods for 3-wire ungrounded and 4-wire multi-grounded systems with remote supply voltage transformer.

**Figure 14** illustrates grounding on a 3-wire uni-grounded system.

For effective surge protection all control and power conductors for the Form 6 NX-T control must be routed parallel to a corresponding ground path. For example, the AC power supply for the control should be parallel to and equal in length to the transformer ground path. The control cable should be parallel to and routed close to the recloser ground path.

**Grounding with a local supply voltage transformer; 4-wire multi-grounded, 3-wire ungrounded, or impedance-grounded**

Installation of the Form 6 NX-T control must include the following:

- Protection of the recloser bushings and the supplying transformer with lightning arresters.
- Grounding of all recloser head(s) and tank(s).
- Grounding of the transformer tank.
- Grounding of the control cabinet.
- Grounding of the SCADA equipment

**IMPORTANT**

All external inputs to the Form 6 NX-T control must be routed within 8 inches of their corresponding ground. During a surge, a potential of approximately 1.5 kV per foot can develop in the conductors. Differences between conductor and ground path lengths can add additional stress to the control components in the event of a power surge.

**4-Wire Multi-Grounded Systems****IMPORTANT**

In pole-mounted applications, a ground connection must be made between the recloser, transformer, recloser control, and SCADA equipment for proper protection of the equipment. The pole ground must be sized per local utility practices to minimize the impedance between the recloser and the control.

**3-Wire ungrounded and impedance grounded systems**

The use of a grounding mat may be required depending upon the local safety regulations defining the permissible step and touch potential levels. Consult local regulations for proper grounding procedures.

## Form 6 NX-T microprocessor-based pole-mount recloser control

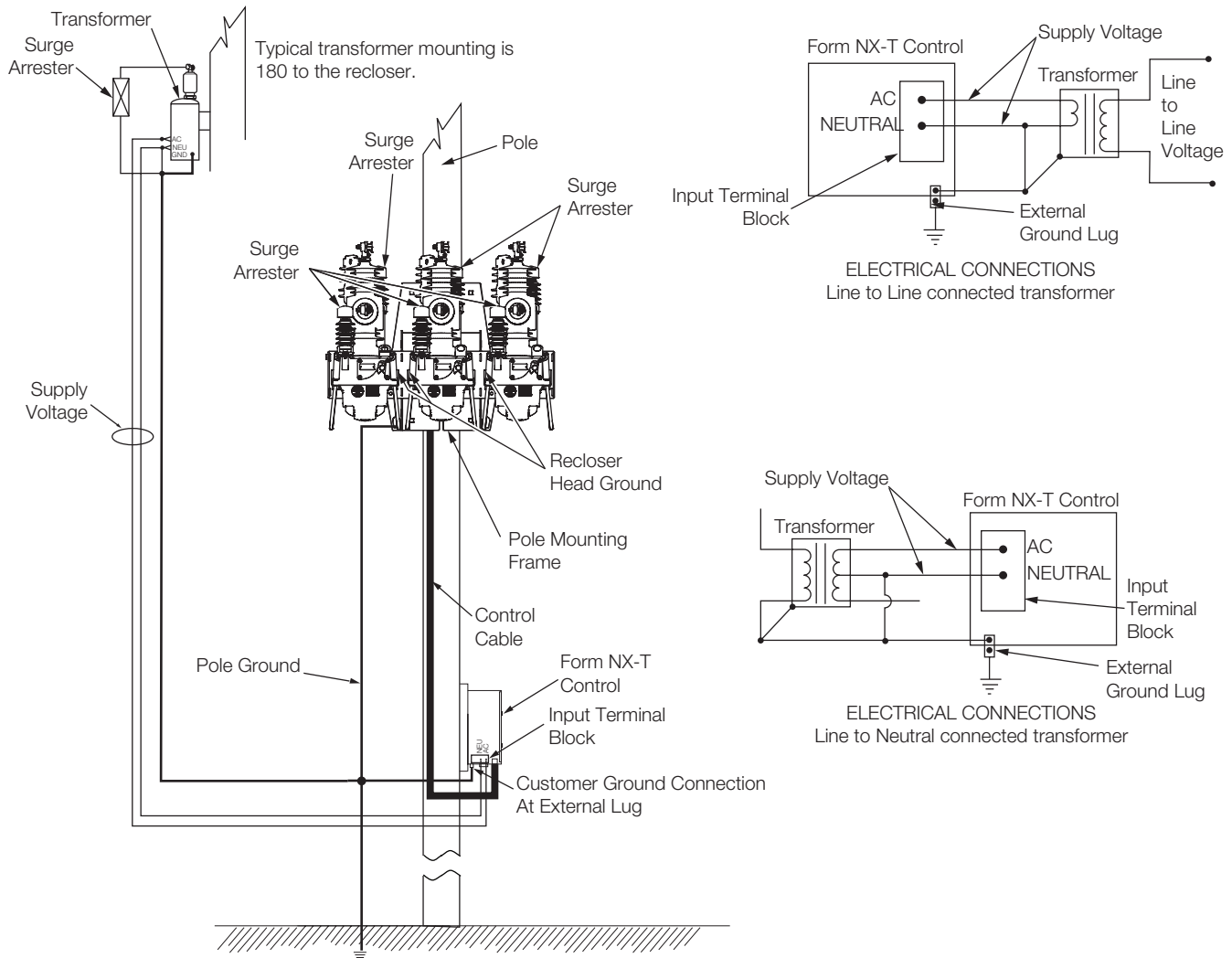

**Figure 12. Recommended grounding method for the Form 6 NX-T control installed on 4-wire multi-grounded, 3-wire ungrounded, or impedance-grounded systems with local supply voltage**

### Grounding with a remote supply voltage transformer; 4-wire multi-grounded, 3-wire ungrounded, or impedance-grounded

Installation of a Form 6 NX-T control with a remote supply voltage transformer must include the following:

- Protection of the recloser bushings and the supplying transformer with lightning arresters.
- Grounding of all recloser head(s) and tank(s).
- Grounding of the transformer tank.
- Grounding of the control cabinet.
- Grounding of the SCADA equipment.

### IMPORTANT

In pole-mounted applications, a ground connection must be made between the recloser, transformer, recloser control, and SCADA equipment for proper protection of the equipment. The pole ground must be sized per local utility practices to minimize the impedance between the recloser and the control.

### IMPORTANT

All external inputs to the Form 6 NX-T control must be routed within 8 inches of their corresponding ground. During a surge, a potential of approximately 1.5 kV per foot can develop in the conductors. Differences between conductor and ground path lengths can add additional stress to the control components in the event of a power surge.

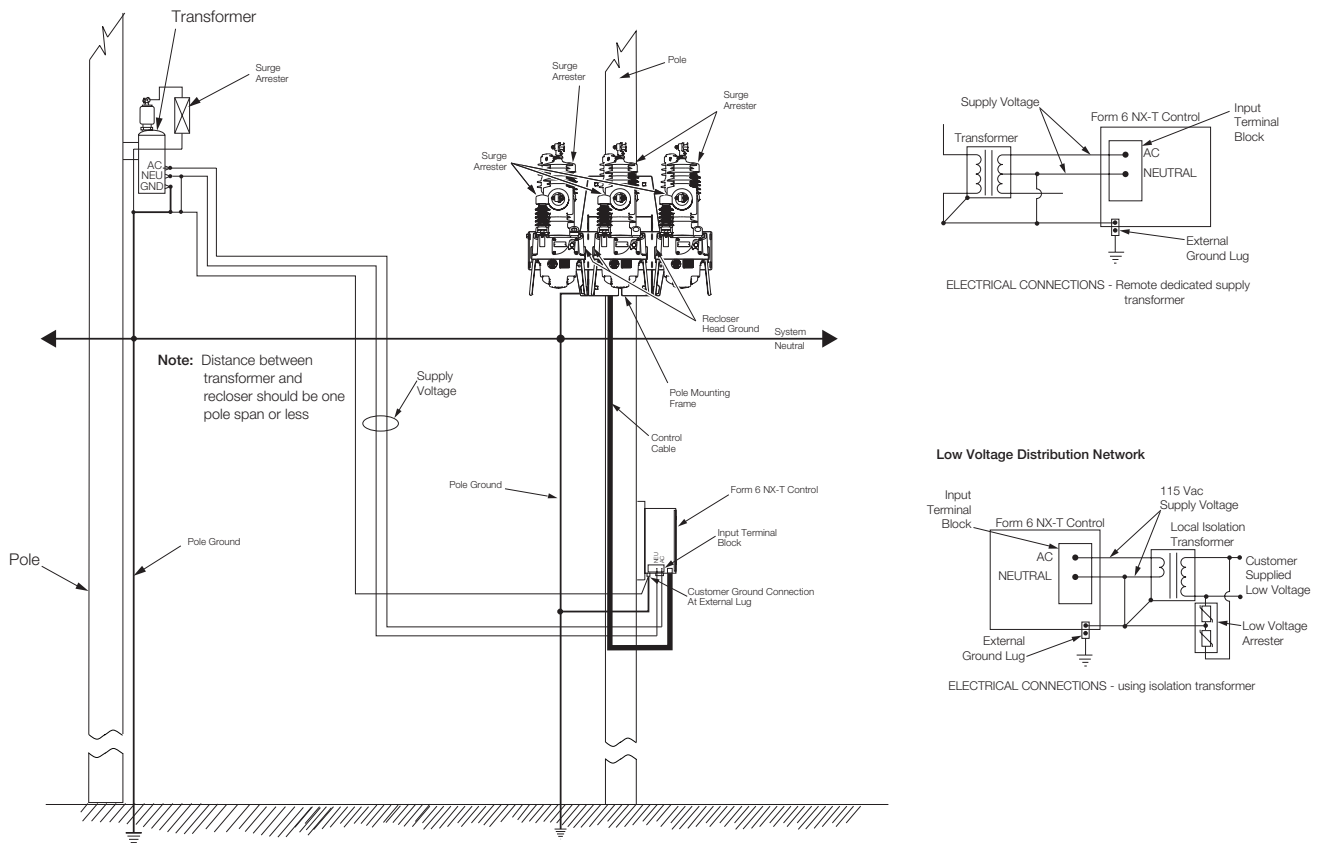

**Figure 13. Recommended grounding method for the Form 6 NX-T Control installed on 4-wire multi-grounded, 3-wire ungrounded, or impedance-grounded systems with remote supply voltage transformer**

**Grounding on a 3-Wire uni-grounded system**

Installation of a Form 6 NX-T control on a 3-wire uni-ground system must include the following:

- Protection of the recloser bushings and the supplying transformer with lightning arresters.
- Grounding of all recloser head(s) and tank(s).
- Grounding of the transformer tank.
- Grounding of the control cabinet.
- Grounding of the SCADA equipment.

**⚠ WARNING**

**Hazardous voltage. Use locally approved operator safety procedures for proper insulation when maintaining this equipment. High Voltage step and touch potential is characteristic in uni-ground systems. Failure to comply can cause death or severe personal injury.**

T262.0

**⚠ CAUTION**

**Exported potential. Do not make direct electrical connections to remote devices. All SCADA equipment must be mounted locally or connected using the fiber-optic or radio communication accessory. Direct connections to remote devices can produce exported potential causing equipment damage or personal injury.**

T263.0

**⚠ CAUTION**

**Hazardous voltage. Do not use a shared low voltage network to power the recloser control unless the network is specifically designed to withstand maximum ground potential rise. Ground faults on a high voltage network can create a rise in ground potential.**

T264.0

**IMPORTANT**

In pole-mounted applications, a ground connection must be made between the recloser, transformer, recloser control, and SCADA equipment for proper protection of the equipment. The pole ground must be sized per local utility practices to minimize the impedance between the recloser and the control.

## IMPORTANT

All external inputs to the Form 6 NX-T control must be routed within 8 inches of their corresponding ground. During a surge, a potential of approximately 1.5 kV per foot can develop in the conductors. Differences between conductor and ground path lengths can add additional stress to the control components in the event of a power surge.

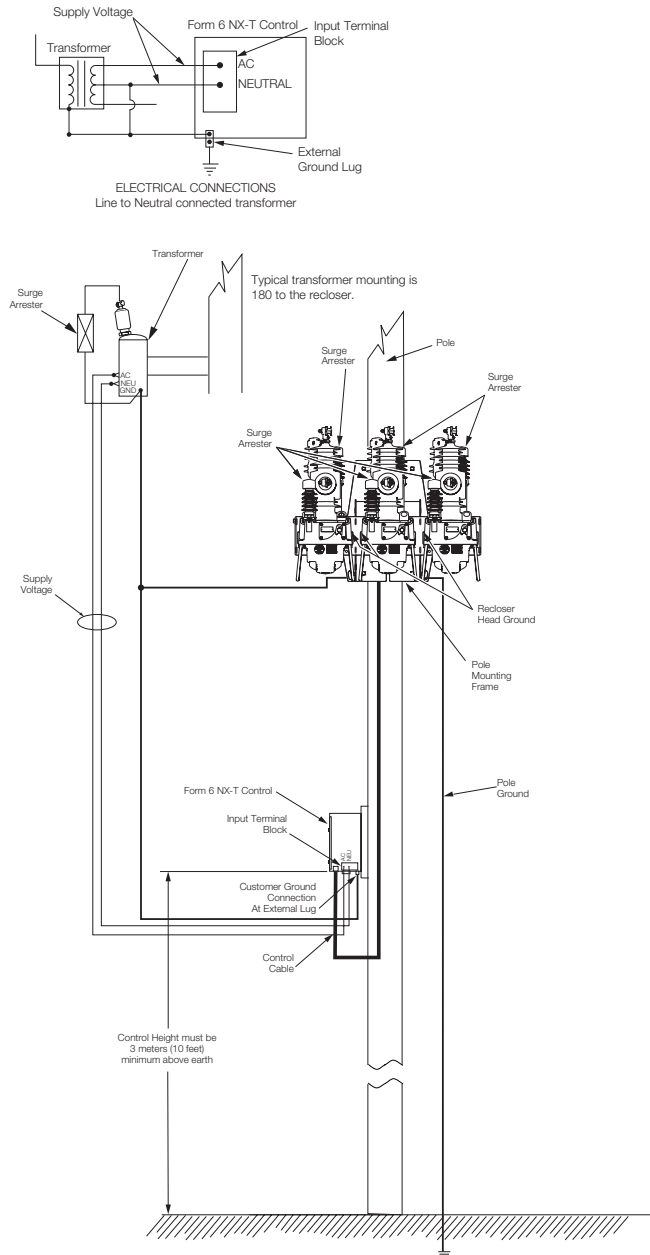

**Figure 14. Recommended grounding method for the Form 6 NX-T control installed on a 3-wire uni-grounded system**

## Customer connections for AC power



**DANGER**

**Hazardous voltage. Do not connect potential transformer low-voltage secondaries to the control through cables or other wiring until the unit is installed in the field. Transformer high-voltage primary windings will become live when 120/240 VAC is applied to the control from an alternate source if the transformer secondary is connected. Failure to comply may result in severe personal injury or death.**

T371.2



**WARNING**

**Hazardous voltage. Before applying power to the control, confirm that male pins of the input power receptacle are electrically insulated to prevent unintentional contact with 120/240 VAC voltage. Failure to do so may result in severe personal injury or death.**

T372.1

## NOTICE

**Equipment damage. Do not drill connection holes into the top of the cabinet. Connection holes in the top of the cabinet will allow moisture to seep into the control and damage the components or cause control misoperation. Failure to comply will void the control's factory warranty.**

T249.0

Input power to the Form 6 NX-T recloser control is connected to terminal block TB7 for single-phase power or TB8 for three-phase power. See **Figure 17**, **Figure 19**, and **Figure 21**. For single-phase incoming voltage supply for 120 VAC or 240 VAC, connect to TB7 as shown in **Figure 17**. For three-phase incoming voltage supply, the user should supply and connect to TB8 as shown in **Figure 19**. For 240 Volt, 3-wire transformer connection refer to **Figure 21**.

Input power is required:

- To power the control
- To provide voltage and power metering
- To power the thermostatically controlled heater
- For the convenience outlet accessory

### Power supply/battery charger board

Incoming AC power is routed to the Power Supply/Battery Charger Board designed to accept either 120 VAC or 240 VAC through a selector switch located directly on the board (**Figure 15**). The battery charger includes a temperature-compensated design to optimally charge the control battery. The power supply / battery charger board also includes an auxiliary power supply for connection to communication equipment (radios, modems, etc.). The auxiliary power supply is rated 28 VDC, 65 Watts peak. A separate 28 VDC to 13.8 VDC power supply accessory is available for communication equipment rated for 13.8 VDC. Some additional features are as follows:



- Positive LED indicator for power supply presence
- Selectable 120/240 VAC switch for adapting to multiple transformer connections. The selector switch is factory-set based upon each customer order.
- Self-protective fuse (5 amp, 250 VAC)
- 28 VDC whetting voltage for I/O contact inputs (refer to **Figure 24**)

**WARNING**

**Hazardous Voltage. Do NOT disassemble this module with the control energized or while the “CAPACITOR DISCHARGING” LED is lit. If LED did NOT light when control was de-energized, do NOT disassemble the module and consult manual. Failure to comply could cause severe injury or death.**

**Actuator Control Unit (ACU)**

The Form 6 NX-T has an Actuator Control Unit (ACU) that provides 225 VDC to the actuator during a close or open operation. On the back panel of the Form 6 NX-T module, there are two blue LEDs: CAPACITOR DISCHARGING and READY TO OPERATE WHEN BLINKING.

When the control is fully de-energized (disconnected from AC power and DC battery), the CAPACITOR DISCHARGING LED is lit steady blue. It will take approximately 7 minutes before the LED dims and is unlit. Afterwards, the Form 6 module can be disassembled if access to within the control module is required.

The READY TO OPERATE WHEN BLINKING LED is to demonstrate the operational state of the ACU. Upon booting up the control (either from AC or DC battery), the LED is lit blue for a short period of time before going into a blinking state. When the control is fully powered up, this LED will be blinking and the control is ready to operate to issue a TRIP or CLOSE command to the NOVA NX-T.

When the control is de-energized, this LED will be unlit and the CAPACITOR DISCHARGING LED will be lit solid blue.

Based upon the ACU design, it is not permissible to have both LEDs energized simultaneously. If the READY TO OPERATE WHEN BLINKING LED is not energized when the control is powered, or the CAPACITOR DISCHARGING LED is not lit when the control is de-energized, contact the factory for further support.

**WARNING**

**Hazardous voltage. Do not touch the pins inside the control cable connector. Pins could be energized if a trip or close signal is issued. Failure to comply could cause severe injury or death.**

**Note:** Control is interlocked such that during normal operation, voltage cannot appear unless correct 52a/b status is reported by the recloser.

**CAUTION**

**Equipment misoperation. Verify that the 120/240 VAC selector switch is correctly set for incoming voltage. Failure to comply may cause misoperation (unintentional operation) of the control and/or equipment damage resulting in personal injury.**

T278.0

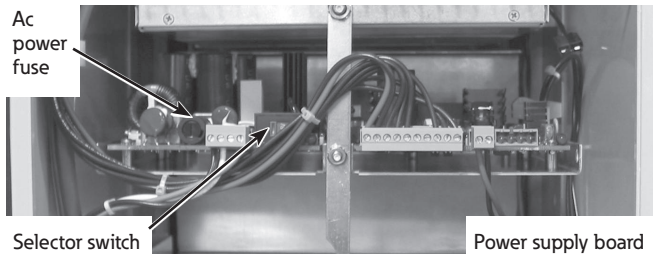

**Figure 15. Power supply/battery charger board**

**IMPORTANT**

Prior to energizing the control, the selector switch must be set as follows:

For 120 VAC incoming power, the selector switch must be set to the 115 V position.

For 240 VAC incoming power, the selector switch must be set to the 230 V position.

**Terminal blocks**

Two terminal blocks are used for connection to the Form 6 NX-T recloser control. Both terminal blocks are fit for a #6 screw which can allow a maximum ring size for a #10 AWG for metering.

Terminal Block TB7 provides power to the Form 6 NX-T control and is directly connected to the power supply circuit board. Terminal Block TB8 is used to connect sensing transformer voltage. The wiring of the transformers should follow the application illustrations per **Figure 18**, **Figure 19**, **Figure 20**, and **Figure 21**.

Default factory wiring includes connection of two wires from Power Supply Terminal Block TB7 to the Metering Terminal Block TB8. See **Figure 16**.

**Figure 20** shows customer connections for TB8, 120 VAC Delta Connection.

The wiring from TB7-3 to TB8-3 and from TB7-5 to TB8-4 connects the metering B phase to the control power inputs (**Figure 17**). If the incoming power supply voltage is different, the B phase power supply input must be moved to the appropriate location. See **Figure 18**.

For A phase incoming power, connect to TB8-1.

For C phase incoming power, connect to TB8-5.

**Note:** Terminal Block positions TB7-3 and TB7-4 are factory-jumpered together.

# Form 6 NX-T microprocessor-based pole-mount recloser control

**Note:** Terminal Block positions TB7-5 and TB7-6 are factory-jumpered together.

### Power connections

The transformer required for power should be a minimum of 1 kVA.

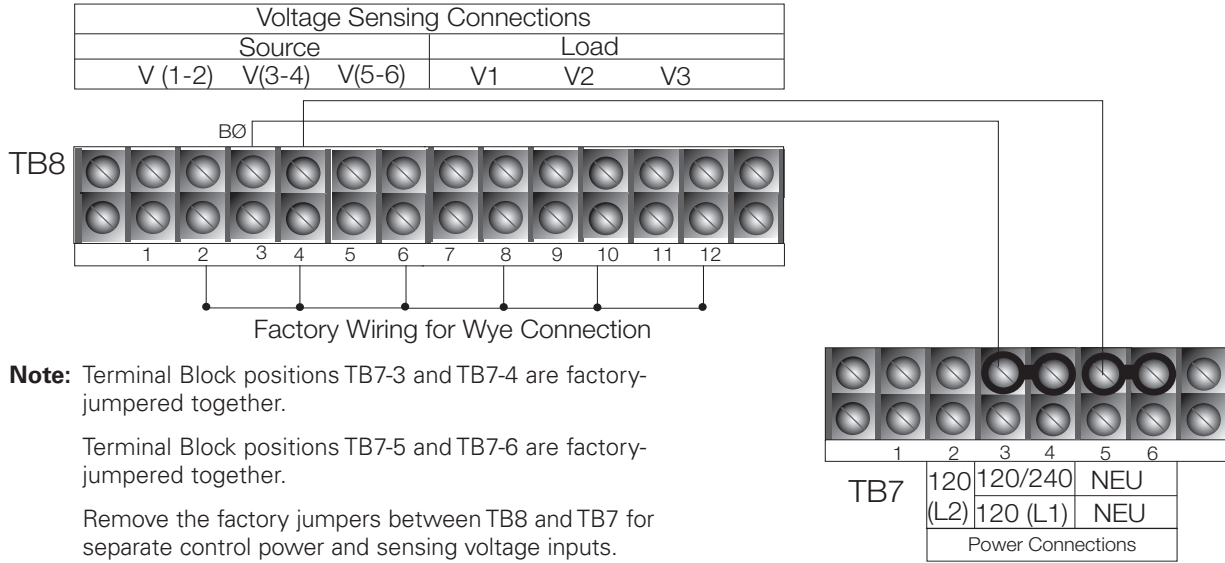

**Note:** Terminal Block positions TB7-3 and TB7-4 are factory-jumpered together.

Terminal Block positions TB7-5 and TB7-6 are factory-jumpered together.

Remove the factory jumpers between TB8 and TB7 for separate control power and sensing voltage inputs.

**Figure 16. Default factory wiring connected to B-Phase voltage metering with B-Phase incoming supply**

## ⚠ DANGER

**Hazardous voltage. Do not connect potential transformer low-voltage secondaries to the control through cables or other wiring until the unit is installed in the field. Transformer high-voltage primary windings will become live when 120/240 VAC is applied to the control from an alternate source if the transformer secondary is connected. Failure to comply may result in severe personal injury or death.**

T371.2

## ⚠ WARNING

**Hazardous voltage. Before applying power to the control, confirm that male pins of the input power receptacle are electrically insulated to prevent unintentional contact with 120/240 VAC voltage. Failure to do so may result in severe personal injury or death.**

T372.1

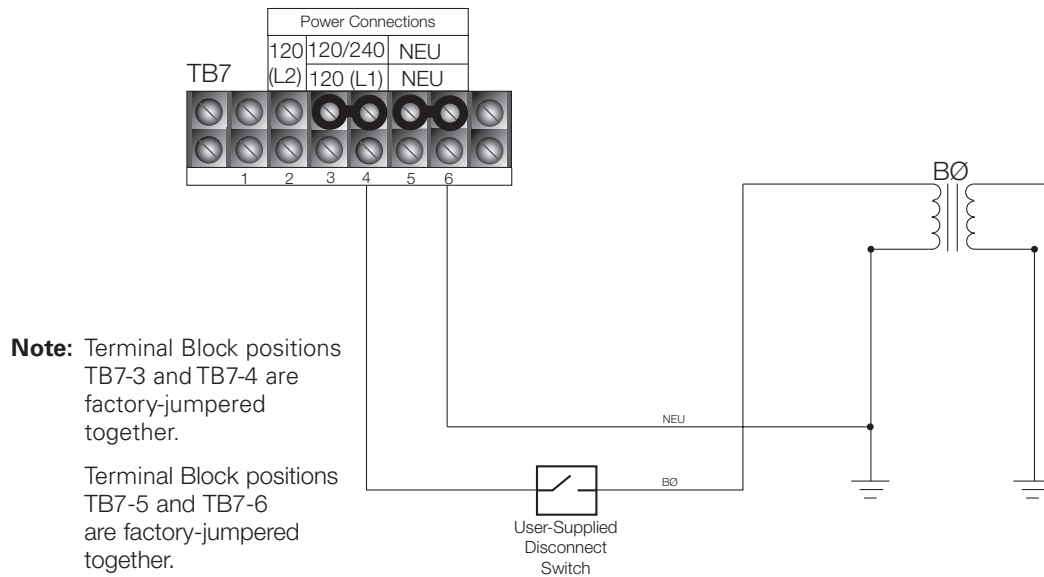

**Note:** Terminal Block positions TB7-3 and TB7-4 are factory-jumpered together.

Terminal Block positions TB7-5 and TB7-6 are factory-jumpered together.

**Figure 17. Single-phase transformer connection, b phase input for power and sensing**

**⚠ DANGER**

**Hazardous voltage. Do not connect potential transformer low-voltage secondaries to the control through cables or other wiring until the unit is installed in the field. Transformer high-voltage primary windings will become live when 120/240 VAC is applied to the control from an alternate source if the transformer secondary is connected. Failure to comply may result in severe personal injury or death.**

T371.2

**⚠ WARNING**

**Hazardous voltage. Before applying power to the control, confirm that male pins of the input power receptacle are electrically insulated to prevent unintentional contact with 120/240 VAC voltage. Failure to do so may result in severe personal injury or death.**

T372.1

Voltage Sensing Connections					
Source			Load		
V (1-2)	V(3-4)	V(5-6)	V1	V2	V3

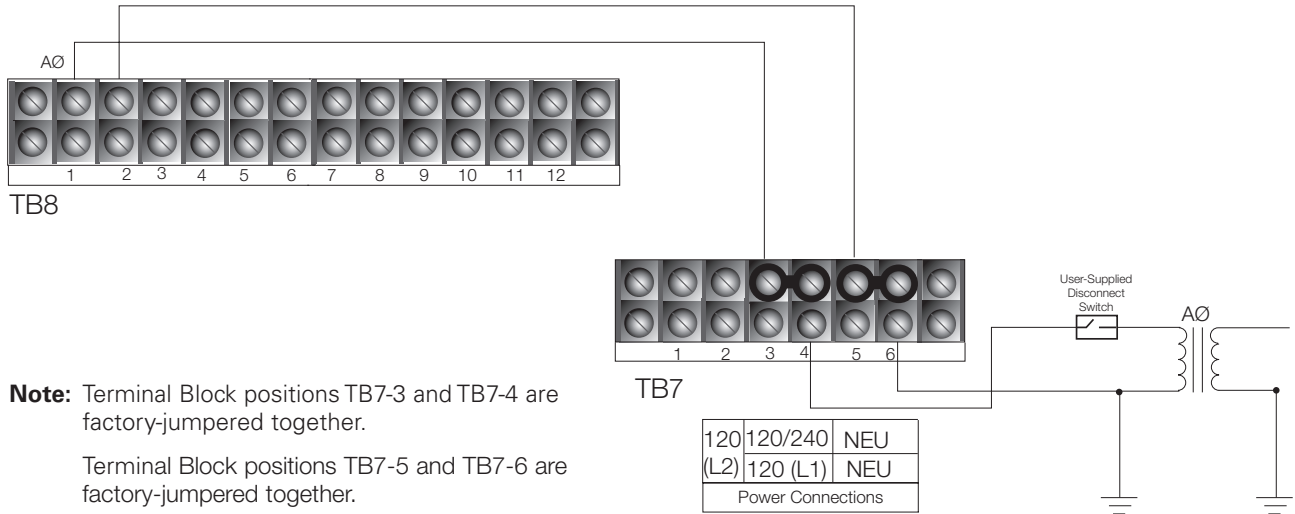

**Figure 18. Modified wiring connected to A-Phase voltage metering with A-Phase incoming supply**

**⚠ DANGER**

**Hazardous voltage. Do not connect potential transformer low-voltage secondaries to the control through cables or other wiring until the unit is installed in the field. Transformer high-voltage primary windings will become live when 120/240 VAC is applied to the control from an alternate source if the transformer secondary is connected. Failure to comply may result in severe personal injury or death.**

T371.2

**⚠ WARNING**

**Hazardous voltage. Before applying power to the control, confirm that male pins of the input power receptacle are electrically insulated to prevent unintentional contact with 120/240 VAC voltage. Failure to do so may result in severe personal injury or death.**

T372.1

TB8

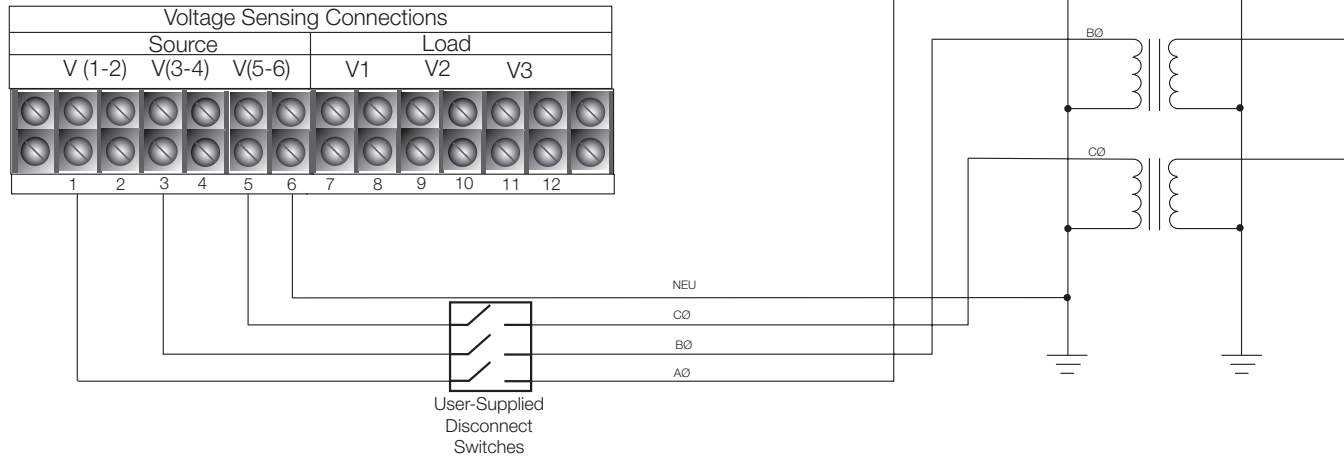

**Figure 19. Three-phase transformer connection, wye configuration only (TB8 terminal block connection)**

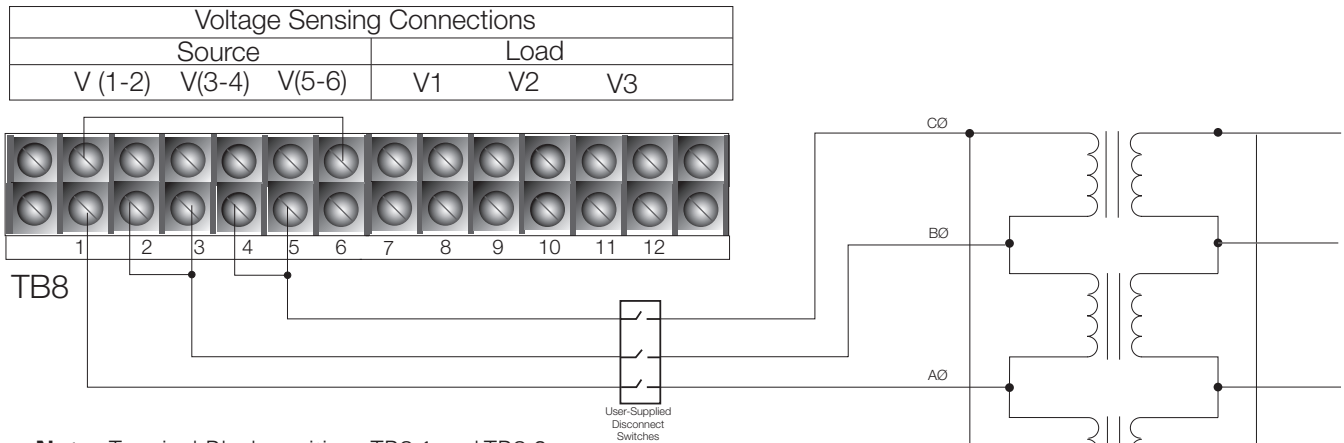

**Note:** Terminal Block positions TB8-1 and TB8-6 are factory-jumpered together.  
 Terminal Block positions TB8-2 and TB8-3 are factory-jumpered together.  
 Terminal Block positions TB8-4 and TB8-5 are factory-jumpered together.

**Figure 20. Customer connections to TB8, 120 VAC delta connection**

**⚠ DANGER**

**Hazardous voltage. Do not connect potential transformer low-voltage secondaries to the control through cables or other wiring until the unit is installed in the field. Transformer high-voltage primary windings will become live when 120/240 VAC is applied to the control from an alternate source if the transformer secondary is connected. Failure to comply may result in severe personal injury or death.**

T371.2

**⚠ WARNING**

**Hazardous voltage. Before applying power to the control, confirm that male pins of the input power receptacle are electrically insulated to prevent unintentional contact with 120/240 VAC voltage. Failure to do so may result in severe personal injury or death.**

T372.1

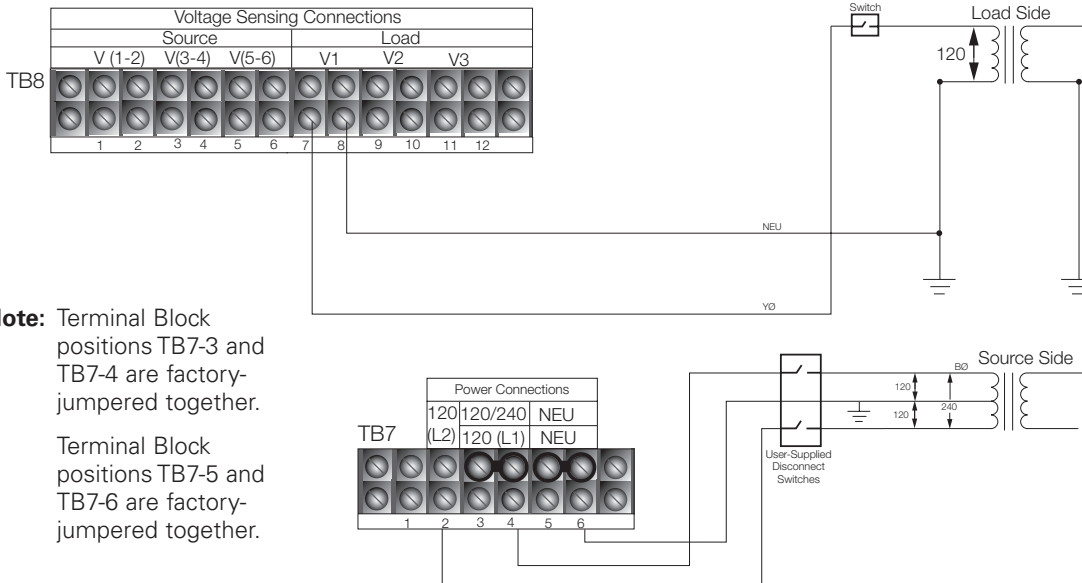

Figure 21. 240 Volt, 3-wire transformer connection. B phase input for power and sensing. \*YØ for sync check voltage

**Standard default supervisory input control and output status contacts**

Standard customer connections TB1 and accessory customer connections are TB3 and TB4. Refer to **Figure 22** and **Figure 23**, and **Table 2**, **Table 3**, and **Table 4**. The Idea Workbench allows customization of all the control and status points. Refer to the *Form 6 NX-T Programming Guide* for additional information.

**NOTICE**

**External leads must be shielded and the shield must be grounded at both ends. Terminate each lead with a 320 VAC, 150 Joules metal oxide varistor (MOV), or equivalent, at the remote end. Attach MOVs between the leads and ground. Failure to properly shield and protect leads can result in equipment damage and/or unintentional operation.**

**IMPORTANT**

Shielding and surge protection of supervisory cables: all supervisory operation and control monitor leads must be protected within shielded cables. Refer to **Figure 24**.

**Table 2. Operating current requirements for standard and optional supervisory inputs**

Input voltage	Nominal current	Minimum operating time
12 VDC – 250 VDC, 120/240 VAC	2.5 mA	5 milliseconds

**Table 3. Ratings table for output status contacts CO1 through CO12 (Resistive load – pickup time 8 ms, dropout 15 ms)**

Input voltage	Contact rating
120 VAC	8 A
12 VDC	8 A
24 VDC	8 A
48 VDC	1 A
125 VDC	0.4 A

# Form 6 NX-T microprocessor-based pole-mount recloser control

**Table 4. Ratings table for output status contact SS1 (Resistive load – pickup time 2 ms, dropout 15 ms)**

Input voltage	Contact rating
120 VAC	8 A
12 VDC	8 A
24 VDC	8 A
48 VDC	8 A
125 VDC	8 A

## NOTICE

External leads must be shielded and the shield must be grounded at both ends. Terminate each lead with a 320 VAC, 150 Joules metal oxide varistor (MOV), or equivalent, at the remote end. Attach MOVs between the leads and ground. Failure to properly shield and protect leads can result in equipment damage and/or unintentional operation.

## IMPORTANT

Shielding and surge protection of supervisory cables: all supervisory operation and control monitor leads must be protected within shielded cables. Refer to **Figure 24**.

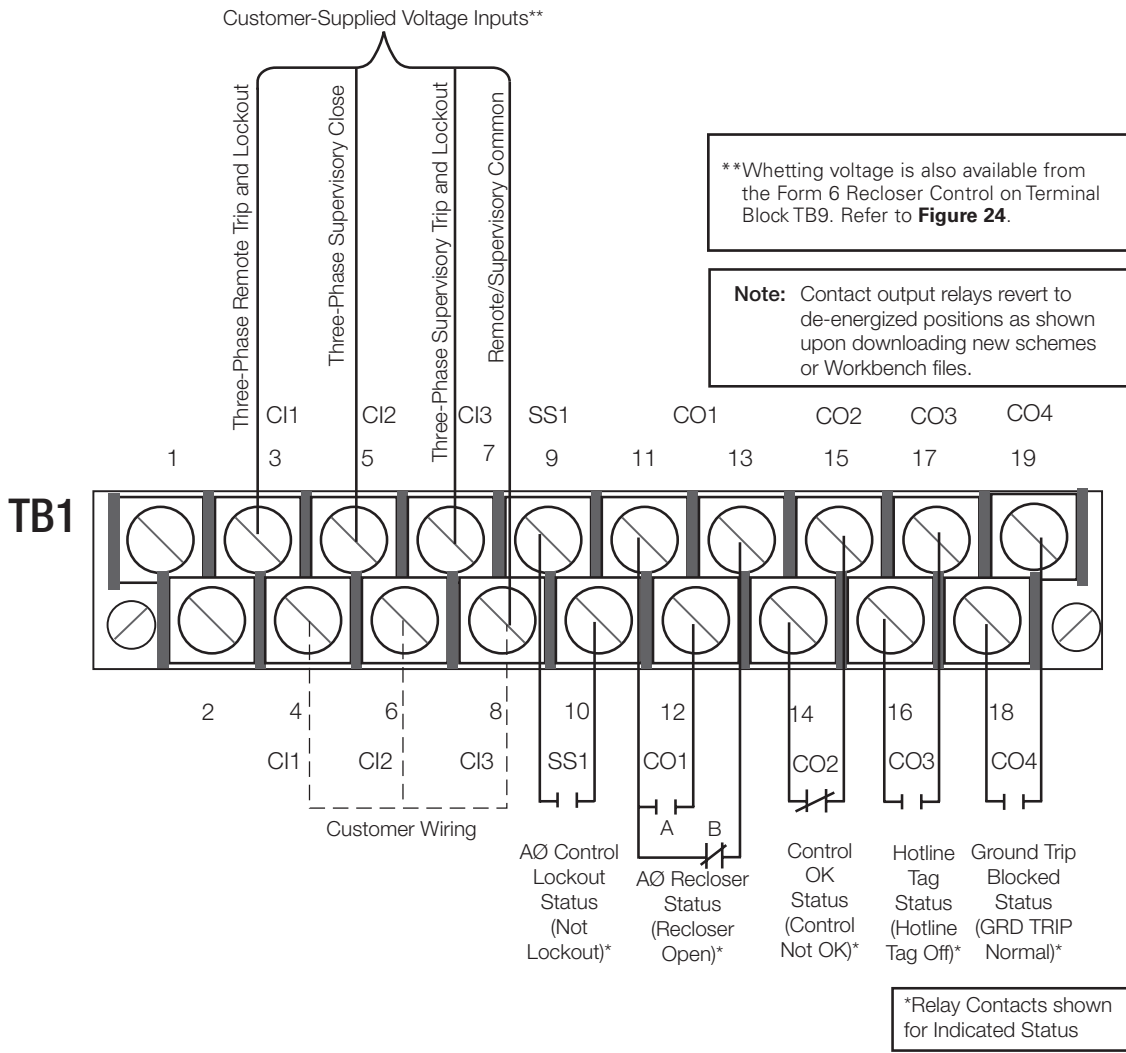

**Figure 22. Form 6 NX-T recloser control standard default supervisory input control and output status contacts. Contacts are shown in de-energized position**

**NOTICE**

External leads must be shielded and the shield must be grounded at both ends. Terminate each lead with a 320 VAC, 150 Joules metal oxide varistor (MOV), or equivalent, at the remote end. Attach MOVs between the leads and ground. Failure to properly shield and protect leads can result in equipment damage and/or unintentional operation.

**IMPORTANT**

Shielding and surge protection of supervisory cables: all supervisory operation and control monitor leads must be protected within shielded cables. Refer to **Figure 24**.

\*\*Whetting voltage is available from the Form 6 Recloser Control on Terminal Block TB9. Refer to **Figure 24**.

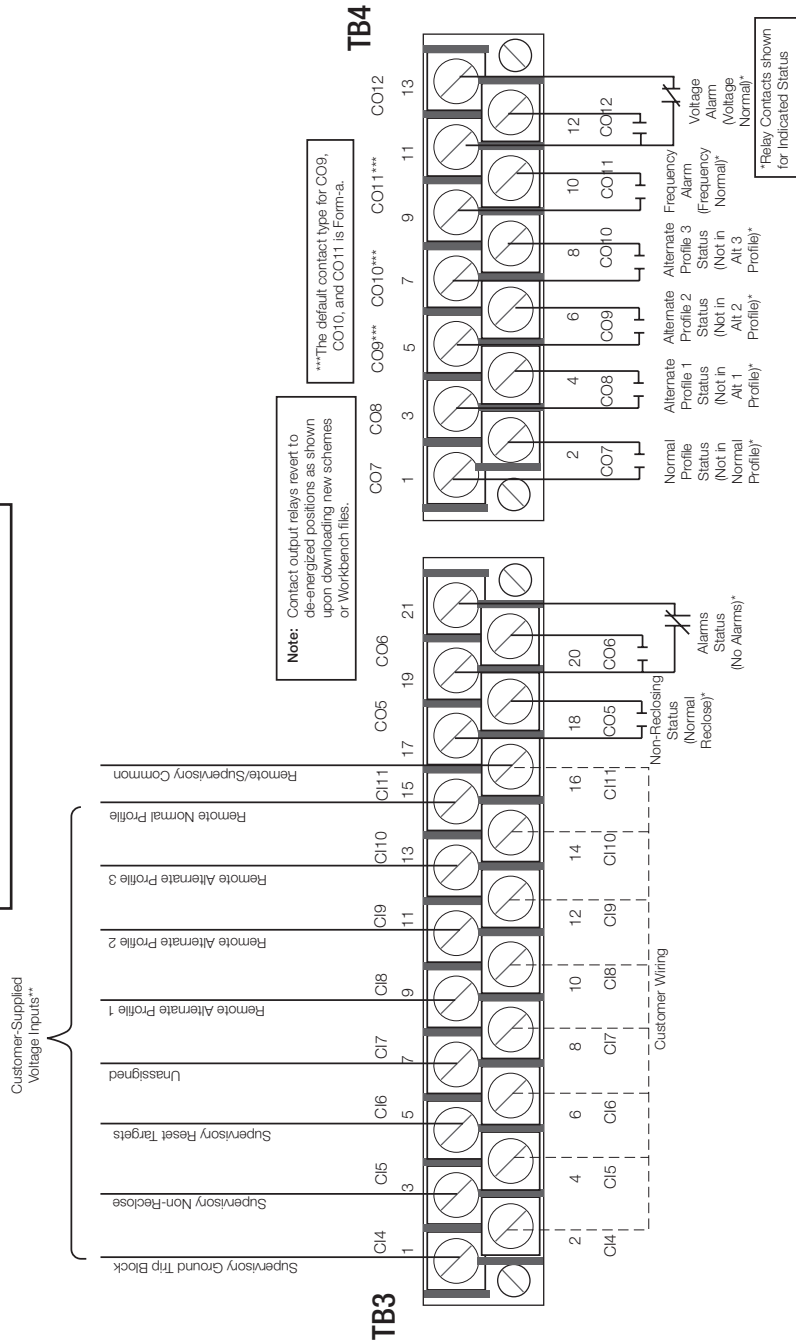
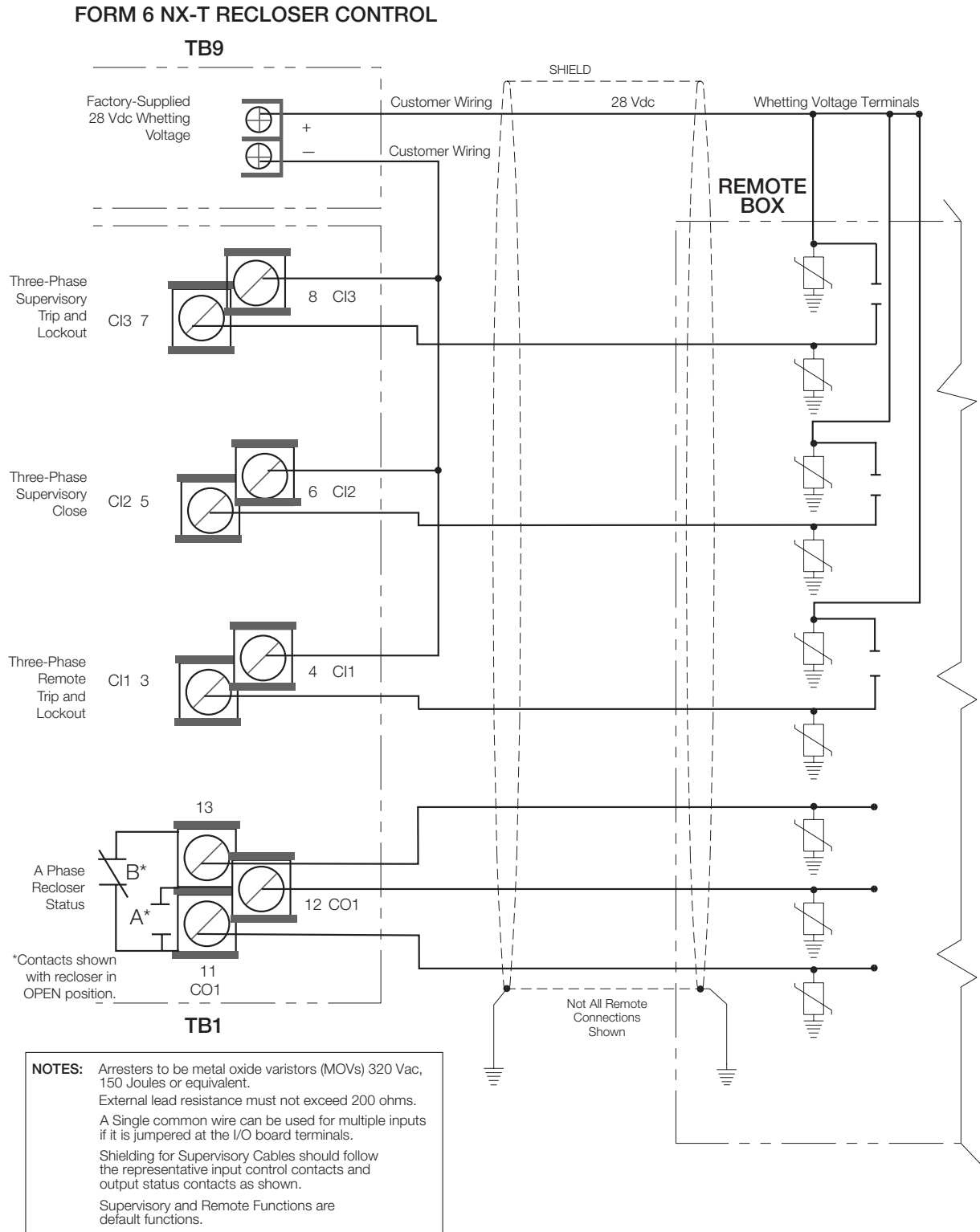

Figure 23. Form 6 NX-T recloser control discrete interface board accessory default supervisory input control and output status contacts. Contacts are shown in de-energized position

# Form 6 NX-T microprocessor-based pole-mount recloser control



**Figure 24. Shielding and surge protection for supervisory and remote cables**



**Rear panel RS-232 communication port pin assignments**

Table 5 indicates the pin assignments for the rear panel RS-232 communication port (Figure 25). Refer to Figure 26 for pin identification. Refer to Communication protocols for additional information.

Refer to the Accessories section of this manual for additional communication options.

**Table 5. Rear panel RS-232 communication port pin assignments**

Pin Number	Signal Name
1 DCD	Carrier detect
2 RXD	Receive data
3 TXD	Transmit data
4 DTR	Data terminal ready (Not Connected)
5 GND	Signal Ground
6 DSR	Data Set Ready (Not Connected)
7 RTS	Request to Send
8 CTS	Clear to Send
9 N.C.	Not Used
10 (Shroud)	Chassis Ground

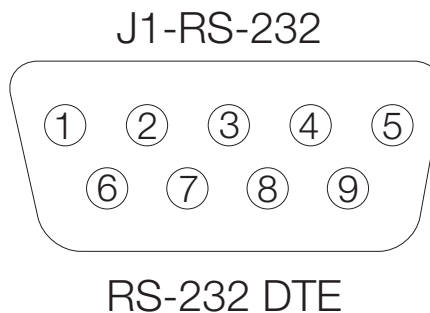

**Figure 26. Rear Panel RS-232 Communication Port Pin Identification**

**Before placing the control and the recloser into service**

**CAUTION**

**Equipment misoperation. Do not connect this control to an energized recloser until all control settings have been properly programmed and verified. Refer to the programming information for this control. Failure to comply can result in control and recloser misoperation, equipment damage, and personal injury.**

G110.3

Prior to placing the control and recloser into service, the following installation procedures must be properly completed and verified:

1. Front panel label inserts changed (if applicable).
- Note:** Refer to **Using removable inserts** in this manual.
2. Control properly mounted for the installation.
3. Recloser installed according to all locally approved standards and practices.
4. AC disconnect switches installed.
5. Control and reclosers properly grounded in accordance with guidelines in this manual and the appropriate recloser manual.
  - Service Information MN280087EN NOVA NX-T Recloser Installation and Operation Instructions
6. Control cables properly connected and supported.

**CAUTION**

**Equipment misoperation. Verify that the 120/240 VAC selector switch is correctly set for incoming voltage. Failure to comply may cause misoperation (unintentional operation) of the control and/or equipment damage resulting in personal injury.**

T278.0

7. Verify the selector switch on the Power Supply/Battery Charger Board is set to the correct position based upon the incoming power supply:

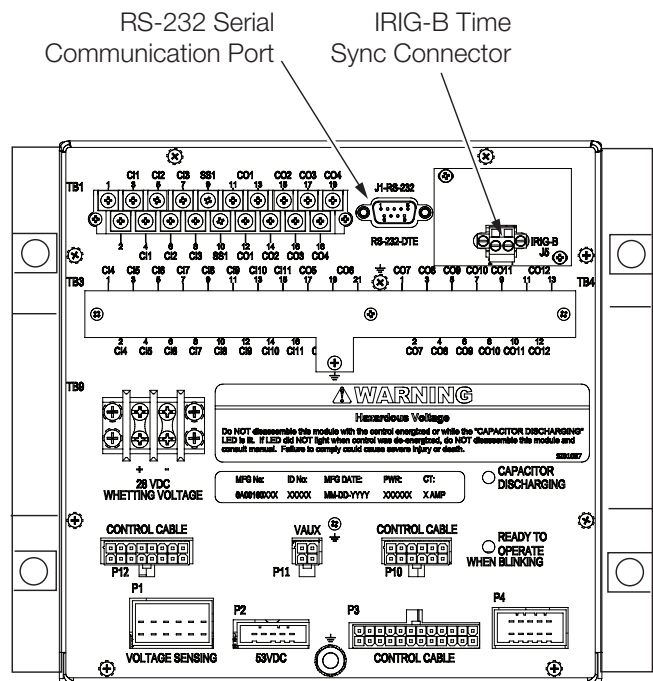

**Figure 25. Form 6 NX-T recloser control rear panel RS-232 communication ports (standard configuration)**

## Form 6 NX-T microprocessor-based pole-mount recloser control

- For 120 VAC incoming power, the selector switch must be set to the 115 V position.
  - For 240 VAC incoming power, the selector switch must be set to the 230 V position.
8. Control battery connected and tested for proper operation.
- Note:** The battery test is blocked for 30 seconds upon power-up of the control.

Test the battery as follows:

- a. Press the MENU button on the front panel.
- b. Using the down arrow key, navigate to the BATTERY menu and press ENTER.
- c. Using the down arrow key, navigate to the TEST BATTERY menu and press ENTER.
- d. Press the F4 button to test the battery.

**Note:** This message will appear on the programming panel LCD display: —TESTING—

The battery test results will display in the battery metering menu.

**Note:** With AC disconnected and the battery supplying the load, current will read -400 to -600 mA depending on accessories connected.

9. AC power connected to the control. (Control OK LED indicator is illuminated.)
- Note:** The control Power Save feature will turn off the backlit LCD display and all LEDs if no front panel keypad is pressed within ten minutes.
10. All control programming entered and verified by appropriate personnel.
- Note:** Refer to the *Form 6 NX-T Programming Guide* for additional information.
11. Control clock set to the correct time.
- Note:** Refer to the *Form 6 NX-T Programming Guide* for additional information.
12. Customer connections for remote and supervisory operation checked and completed in accordance with proper shielding and surge protection (**Figure 24**).

### NOTICE

**External leads must be shielded and the shield must be grounded at both ends. Terminate each lead with a 320 VAC, 150 Joules metal oxide varistor (MOV), or equivalent, at the remote end. Attach MOVs between the leads and ground. Failure to properly shield and protect leads can result in equipment damage and/or unintentional operation.**

### Using removable inserts

#### WARNING

**Hazardous Voltage. Do NOT disassemble this module with the control energized or while the “CAPACITOR DISCHARGING” LED is lit. If LED did NOT light when control was de-energized, do NOT disassemble the module and consult manual. Failure to comply could cause severe injury or death.**

#### NOTICE

**Control damage. De-energize both AC and DC power prior to removing or installing any internal connections or circuit boards in the control. Failure to comply can result in damage to the control.**

T241.1

#### NOTICE

**Equipment damage. Always wear a grounding wrist strap to control static electricity before handling circuit boards. Failure to use this strap may result in circuit board damage.**

T253.1

The front panel inserts can be changed, if desired.

1. De-energize both AC and DC power. Verify the CAPACITOR CHARGING blue LED is off after 7 minutes (approximately) before continuing.
2. Use a flathead or 3/32 inch hex key screwdriver to unscrew the six front panel screws.
3. Pull the right side of the front panel out towards the left (**Figure 27**).

**Note:** Various connecting wires will keep the panel attached to the control.

**Note:** It is not necessary to disconnect any wires.



**Figure 27. Open front panel. Labels are easily removed from and inserted into the top of the programming panel LED status indicator section**

- Use tweezers to gently pull out the removable insert.
- Note:** The insert will slide out of the right side of the operating panel (**Figure 28**).
- Note:** The insert will slide out of the top of the programming panel indicator section (**Figure 27**).
- Change the existing label or slide in a new label with the name of the programmed option.

An electronic label template is included on the ProView application software CD and can be accessed through the following default address:

C:\Program Files\Cooper\ProviewXX\Form 6\Form 6 Inserts.doc

**IMPORTANT**

Laminate the removable inserts prior to installing. This will seal the ink/toner and avoid damage to the front panel.

- Gently push the removable insert from right to left into the right side of the operating panel (**Figure 28**) or down into the programming panel LED indicator section (**Figure 27**).

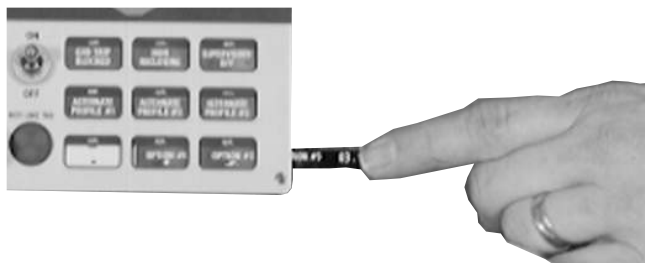

**Figure 28. Labels are easily removed from and inserted into the operating panel**

- Place the front cover panel back onto the control. Using a 3/32 inch hex key screwdriver screw the screws into the control and tighten all hardware completely.

**Accessories**

These accessories are available. Contact your Eaton representative for additional information.

**Incoming power receptacles**

The Incoming Power Receptacle allows the user to conveniently plug the power cable into the control, eliminating the need for hardwiring to the control. Various options are available based upon the input power voltage, and phase sensing requirements. **Table 6** includes the available input receptacles for the control.

**Table 6. Input and heater receptacles**

Description	Catalog number
120 VAC or 240 VAC input receptacle, 2-pin	KME6-1775-H
120 VAC input receptacle, 3-pin	KME6-1775-J
240 VAC input receptacle, 3-pin	KME6-1775-K
(2) 2-pin input receptacles for dual source/transfer relay	KME6-1775-N

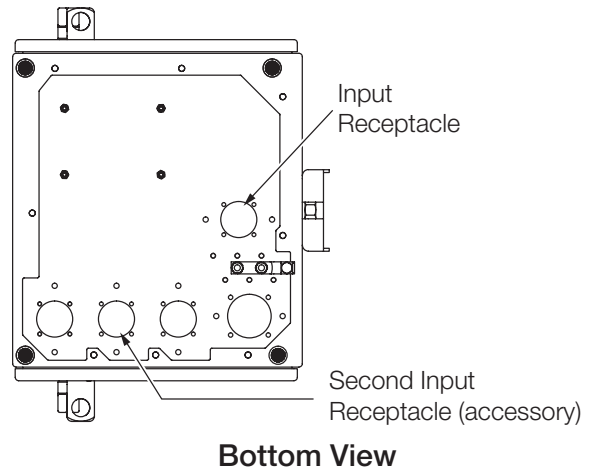

**Figure 29. Form 6 NX-T recloser control input receptacle locations**

**Discrete interface board (DIF) option accessory**

A Discrete Interface Board Option accessory provides eight configurable input control contacts and eight configurable output status contacts (**Figure 30**). The ordering options include: Standard (3 inputs/5 outputs) or Additional (8 inputs/8 outputs).

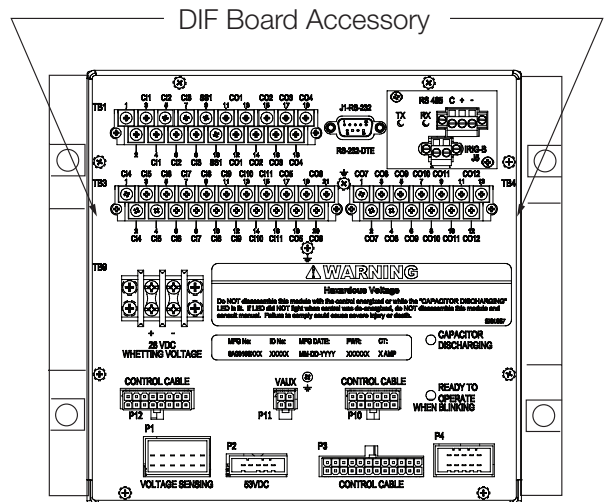

**Figure 30. Form 6 NX-T recloser control discrete interface board accessory**

## Form 6 NX-T microprocessor-based pole-mount recloser control

### Cable locking sleeves

To prevent detachment of the control cable from the control cabinet by unauthorized personnel, a cable-locking sleeve is available to enclose the cable plug. The plug is passed through the sleeve and the sleeve is then fastened from inside the control cabinet. There is no access to the cable receptacle without opening the locked cabinet door and detaching the sleeve.

### RS-232 cable

A nine-pin RS-232 Cable is available to connect from the personal computer to the data port on the front panel of the Form 6 NX-T pole-mount recloser control. The front panel RS-232 port is wired as a DCE port for direct connection to the personal computer.

### Stainless steel cabinet

A cabinet constructed from AISI 304 stainless steel is available as an accessory.

### 120 VAC GFI duplex outlet

The GFI Duplex Outlet is available for controls powered by 120 VAC or 240 VAC three-wire supply power (Wye only). This convenience outlet is rated for 15 Amperes and is accessible through the front door in the control cabinet. The 120 VAC GFI Duplex Outlet is used for many applications such as power for the MET Tester, auxiliary measurement equipment, and supplemental lighting.

### Internal voltage sensing and load side sensing

Internal voltage sensors, located on the source side of the recloser, and load side voltage sensors (located on the load side of the recloser), indicate voltage magnitude within an accuracy 2% or better and a phase degree accuracy within 1.5 degrees (includes sensor, cable, and control).

Refer to *Service Information MN280087EN NOVA NX-T Recloser Installation and Operation Instructions*.

### Radio mounting accessory

The radio mounting accessory (**Figure 31**) is powered from a voltage regulated power supply factory-calibrated with an output of 13.8 VDC.

The radio power supply input is fused by a 1 Amp in-line fuse for a nominal voltage of 28 VDC. The output is 13.8 VDC between P2-1 (+) and P2-2 (-) on the radio power supply circuit board with a maximum continuous watt rating of 17.25 W @ 13.8 VDC.

**Note:** This output cannot be field-calibrated.

The radio will continue to operate during the loss of AC power as long as power is supplied from the battery. The power supply is designed to provide up to 40 Watts (peak) and is fused to isolate any potential radio problems without disturbing the protection system in the recloser control. Refer to **Table 7**.

Contact your Eaton representative for any additional voltage requirements.

There is one standard 9-pin RS-232 and one optional communication port (RS-485, serial fiber, Ethernet wire or fiber or both) on the back operator panel, as well as a standard IRIG-B port for user time-syncing. See **Figure 9**.

**Table 7. Radio mounting accessories**

Description	Catalog number
Full Automation accessory	
12 VDC radio provision	KME6-1774-3
(Radio and fiber-optic/RS232 interface not included) Automation accessory (bracket only)	
12 VDC provision	KME6-1774-2

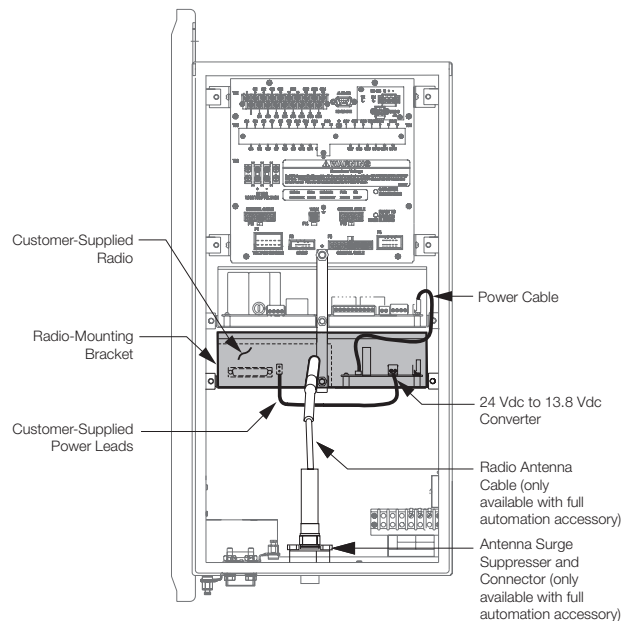

**Figure 31. Form 6 NX-T recloser control radio mounting accessory**

### Communication board accessory

The Form 6 NX-T control is equipped with a Communication Board Accessory (expansion bay) offering versatile support for modern communication media. Six distinct communication options (**Figure 32**) are available, providing two-way, real time digital communications with a remote terminal unit (RTU), wireless, telephone modem, Ethernet network, or other communication devices. The following options are available:

- No auxiliary communication card installed (standard)
- RS485 (Isolated) Serial communication card
- Fiber-optic-based Serial Communication Card (ST)

- 10/100 Base-T dual Ethernet communication card (2\* RJ-45)
- 100 Base-FX dual Ethernet communication card (2\* MT-RJ)
- 10/100 Base-T, 100 Base-FX Ethernet communication card (RJ-45 + MT-RJ)

The expansion bay based Communication Board Accessory concept offers high versatility with respect to communication medium and protocol support. Additional accessories are being continuously developed. Contact your Eaton representative for the latest information regarding particular media and communication protocol support.

### RS485 serial communication card

The RS485 serial communication card accessory provides means for establishing asynchronous link-based digital communications with the Form 6 pole-mount control. The Galvanic isolated (1000 VDC) RS485 port uses a single shielded twisted pair connection and can support 32 devices in multi-drop configuration. Communication speed is controlled through software and can be set at: 1200, 2400, 4800, 9600, 19.2 k, and 38.4 k. Modbus can also be set at 57.6 k.

Digital communications must be programmed through the Communications Workbench to ensure proper operation of the RS485 communication card accessory. Refer to the *Form 6 NX-T Programming Guide* for additional protocol support information.

### Fiber-optic based serial communication card

The Fiber-Optic based Serial Communication Card offers means of establishing asynchronous (RS-232 like) digital communications through multi-mode fiber media. The use of the fiber-optic based serial communication card accessory can enhance communication reliability, and provides excellent electrical isolation thus protecting transmitted data from extraneous electrical interference.

An optional fiber-optic-to-RS-232D converter with DB-9 connector (Catalog Number KME6-1875-1) is available for interfacing between an optical signal and a hard-wired RS-232 signal, when required. This converter is compatible with loop (ring) and point-to-point (star) configurations.

A pair of industry standard ST type fiber-optic connectors are mounted on the back of the board enabling customer connection to a digital communication system using fiber-optic cables (customer-supplied).

The fiber-optic link has separate receive (RX) and transmit (TX) ports operating at 820 nm. Typical transmission distance is 2000 m with 62.5/125  $\mu\text{m}$  multi-mode fiber. Consult your Eaton representative for availability of long haul solutions. Link communication speed is controlled through software and can be set at: 1200, 2400, 4800, 9600, 19.2 k, and 38.4 k. Modbus can also be set at 57.6 k.

The fiber-optic accessory must be programmed through the Communications Workbench for the appropriate protocol.

Refer to the *Form 6 NX-T Programming Guide* for additional information.

The fiber-optic based serial accessory includes TX and RX indicating LEDs for verifying communications along with an echo / non echo switch for supporting ring / star fiber topologies.

When operated in a ring configuration, the toggle switch must be set in the ECHO position. In this mode, the fiber-optic card will repeat (pass through) all messages received on the RX fiber, and will respond to the Master station by first echoing the incoming command and then sending the response. This arrangement is best suited for creation of low cost multi device fiber loops. For reliable communications, the fiber loop system requires that all devices in the loop remain powered at all times, thus enabling unobstructed flow of information throughout the loop.

A more resilient system can be designed by using the fiber-optic ports in a point-to-point or multiple point-to-point (star) configuration. For this mode, the toggle switch must be set in the NON-ECHO mode. The Form 6 NX-T control will respond to the Master station by sending a response only (total separation of Receive and Transmit fibers). Additional hardware (fiber-optic star coupler) is required to support the multiple point-to-point device configurations.

### Ethernet communication cards

The Ethernet communication card accessory brings the Ethernet network connectivity to the Form 6 NX-T recloser control platform. It is highly flexible, offering simultaneous support for multiple sessions, device management (ProView over TCP/IP) and SCADA communications (DNP3 over TCP/IP).

By natively supporting a set of widely accepted industry standards (TCP/IP, UDP/IP, OSI) the Ethernet communication accessory ensures seamless interoperability with other network devices.

# Form 6 NX-T microprocessor-based pole-mount recloser control

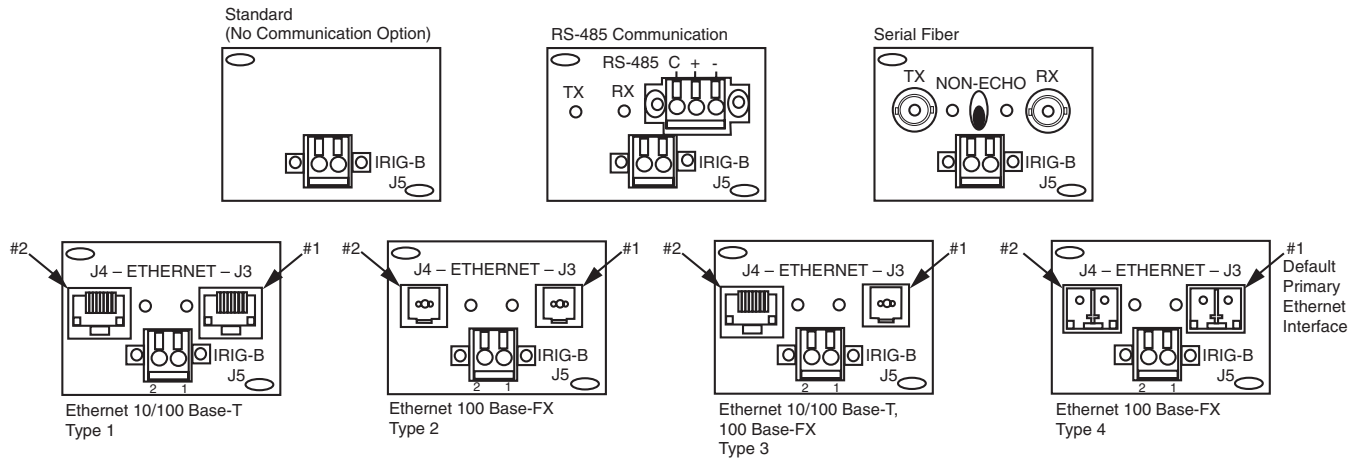

**Figure 32. Back panel ethernet and communication options**

The Ethernet communication card accessory is offered in 3 physical layer configurations (twisted pair and optical-fiber options) as shown in **Table 8**.

**Table 8. Ethernet communication card configurations**

Type	Card configurations	Output connectors	Communication speed
1	10/100 Base-T	2 * RJ-45	10/100 MBps (auto switching)
2	100 Base-FX (multi-mode fiber)	2 * MT-RJ	100 MBps (full duplex)
3	10/100 Base-T, 100 Base-FX	RJ-45 + MT-RJ	10/100 MBps and 100 MBps
4	100 Base-FX, (single-mode fiber)	2 * LC	100 MBps (full duplex)

Maximum link length is determined by the use of the particular physical layer implementation, and can be further constrained by the actual network configuration. In case of the 100Base-FX MT-RJ connector based implementation, maximum link length in excess of 2000 m can be achieved with 62.5/125 μm multi mode fiber. The fiber-optic link uses 1300 nm wavelength, and can easily be interfaced to other 100Base-FX solutions (ST connector patch cord solution).

The Ethernet communication accessory card (**Figure 32**) is equipped with two physical ports configured to act as primary and standby LAN connections. Availability of the backup communication port enables creation of highly redundant Ethernet networks thus increasing the overall system reliability.

**Note:** Under normal network conditions, all communications will be channeled through the primary port (#1, **Figure 32**), with the standby port either logically disabled, or configured for fast automatic throw-over in case of the primary Ethernet link failure. Refer to the *Form 6 NX-T Programming Guide* for additional Ethernet accessory configuration information.

## Testing

### ⚠ CAUTION

**Equipment misoperation. Do not connect this control to an energized recloser until all control settings have been properly programmed and verified. Refer to the programming information for this control. Failure to comply can result in control and recloser misoperation, equipment damage, and personal injury.**

G110.3

### IMPORTANT

The Form 6 NX-T control can be taken out of service for testing and placed back into service without de-energizing its recloser and interrupting the system. However, during the time the control is out of service, the recloser is inoperative.

### Testing an installed control

The following tests to determine initial operation of the Form 6 NX-T recloser control can be performed while connected to an operating recloser.

**Note:** These are the only tests performed on an installed, operating control.

1. Verify operating status of all indicator lights by pressing and holding the LAMP TEST key for two seconds on the programming panel (**Figure 33**).
2. Check the operational values for currents, voltages, and other metering information.

**Note:** Scroll through the LCD display messages by pressing the ▲ and ▼ cursor movement arrows underneath the LCD display on the programming panel (**Figure 33**).

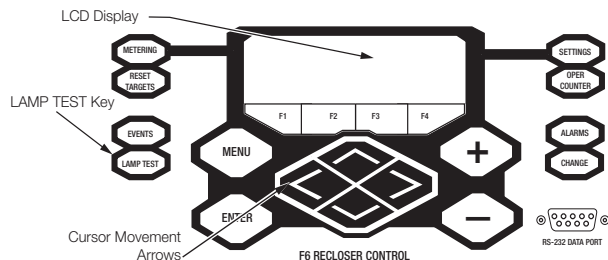

**Figure 33. Lamp test button, LCD display, and cursor movement arrows**

3. Test battery operation as follows:

**Note:** The battery test is blocked for 30 seconds upon power up of the control.

**Note:** AC power can be either connected or disconnected for battery test.

- a. Press the MENU button on the front panel.
- b. Using the down arrow key, navigate to the BATTERY menu, and press ENTER.
- c. Using the down arrow key, navigate to the TEST BATTERY menu and press ENTER.
- d. Press the F4 button to test the battery.

**Note:** This message will appear on the programming panel LCD display: ---TESTING---

The battery test results will display in the battery metering menu.

**Note:** Voltage should be between 25 – 31 VDC – with the higher voltage at colder temperatures.

Under normal conditions, with AC connected and a fully charged battery, the charging current should be less than 20 mA.

With AC connected and a discharged battery, the current range should be 20 – 450 mA.

With AC disconnected and the battery supplying the load, current will read -400 to -600 mA depending on accessories connected.

4. Verify the Control OK LED is illuminated on the control operator panel (**Figure 34**). This indicates the presence of AC power.

**Note:** The control includes a Power Save feature that will turn off the backlit LCD display and all LEDs if no front panel keypad is pressed within ten minutes. Pressing the LAMP TEST key will reactivate the display and active LEDs.

All other tests described in this **Testing** section require the Form 6 NX-T recloser control to be removed from service, connected to a bypassed recloser, or tested at a location where the proper testing equipment is available.

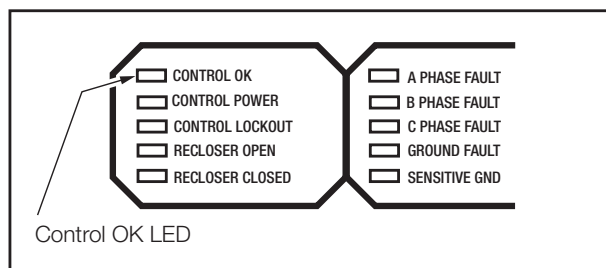

**Figure 34. Control OK LED**

**Remove the control from service**

**IMPORTANT**

Disconnect switches for AC sensing and power connections are necessary to isolate the Form 6 NX-T control for testing and servicing.

**IMPORTANT**

The control must be removed from service in the **exact order** specified in this section.

1. Enable GND TRIP BLOCKED to allow for ground trip to be disabled when re-energized.
  - a. Press the CHANGE button on the Operator Panel to enter the CHANGE mode.
  - b. Depress the GND TRIP BLOCKED button within ten seconds after entering the CHANGE mode.

**Note:** If the GND TRIP BLOCK button is not depressed within ten seconds, the function is not activated.
2. Disconnect the battery.
3. Remove control AC sensing and power connections from the control using a separate disconnect switch.

**CAUTION**

**Hazardous voltage. Open CT secondaries can generate high voltages. Contact with CT pins of the disconnected cable can cause electric shock and may result in personal injury. Open recloser contacts and open disconnect switches before disconnecting control cable.**

T204.3

**NOTICE**

**Equipment misoperation. Disconnect all control power sources prior to disconnecting or reconnection the control cable from the control. Failure to comply can result in recloser misoperation at the time of disconnection or reconnection of the control cable to the control.**

T311.1

4. Disconnect control cable from control.

## Form 6 NX-T microprocessor-based pole-mount recloser control

**Note:** Do not disconnect any of the recloser cables from the recloser(s) or integrated junction box unless all of the above steps have been completed. Refer to the appropriate recloser instructions:

- *Service Information MN280087EN NOVA NX-T Recloser Installation and Operation Instructions*
5. Remove any control input and status output wiring from TB1, TB3, and TB4 (**Figure 36**).
  6. Disconnect any serial communications ports and IRIG-B timing connections (**Figure 36**).
  7. Disconnect the ground from the control.
  8. Carefully transport the control to a suitable service facility.

### Preliminary testing with no AC available

If the Form 6 NX-T control is not in service and requires energization for preliminary testing, it can be powered up with (connected) battery power only.

**Note:** Controls with expanded memory require battery voltage to be 23 VDC minimum.

1. Open the rear door of the Form 6 NX-T pole-mount control cabinet and locate terminals TM1 and TM2 on the power supply circuit board (**Figure 35**).

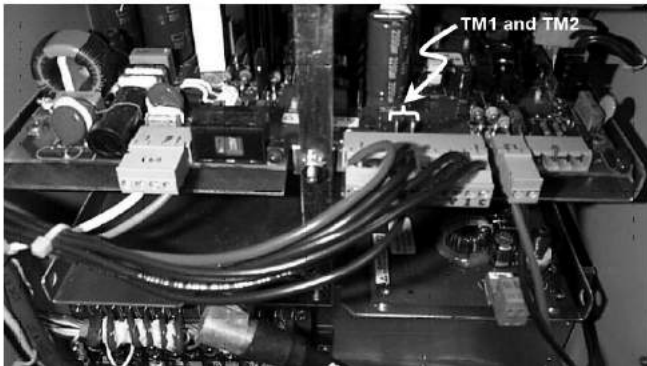

**Figure 35. Location of terminals TM1 and TM2 on the power supply circuit board**

2. Momentarily jumper terminals TM1 and TM2 together. (The control will power up.)
3. To power down the Form 6 NX-T control, unplug the battery (disconnect the black/red battery connector).
4. Perform a battery charging cycle. Refer to **Battery charging** in the **Battery test and charging procedures** section of these instructions.

## IMPORTANT

While the Form 6 NX-T control is powered in this manner, the control battery is being continuously discharged. When the battery voltage drops to 22 VDC, the control will automatically power down.

If the battery is left in a discharged condition, the battery(s) will sustain permanent irreversible damage. Therefore, a battery charging cycle should always be performed after this procedure to bring the battery(s) back up to full charge.

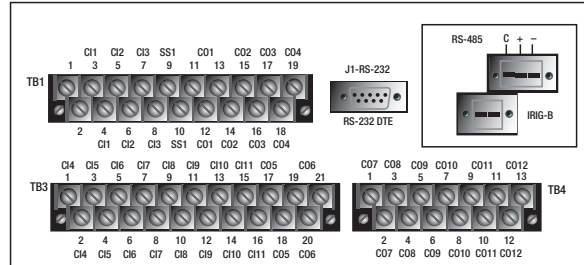

**Figure 36. Back view of top half of Form 6 NX-T recloser control**

### Electrical testing of NOVA NX-T

## WARNING

**Hazardous voltage. Solidly ground all equipment. Failure to comply can result in death, severe personal injury, and equipment damage.**

T223.2

**Figure 37** shows a test circuit for NOVA NX-T reclosers with the Form 6 NX-T control.

## IMPORTANT

To ensure proper operation for the NOVA NX-T recloser, always verify that the three cables between the integrated junction box and the NX-T reclosers are connected when the control is in single-phase trip, three-phase lockout mode or three-phase trip, three-phase lockout (ganged) mode.

Use this circuit to simulate load current and for testing minimum trip operation and sequencing the mechanism with the Form 6 NX-T control for each phase.



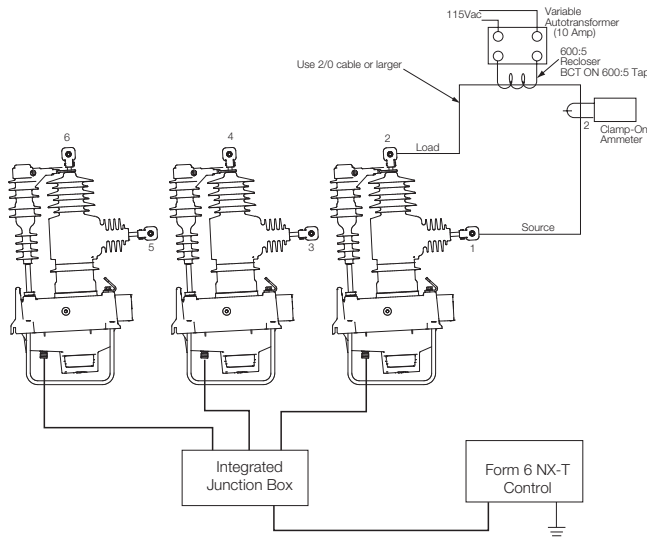

**Figure 37. Suggested test circuit for NOVA NX-T reclosers with Form 6 NX-T control**

## Battery test and charging procedures

### Test procedure for installed battery

Follow the procedure below to perform a battery test in the Form 6 NX-T control. The values in the test procedures are based on testing at 77 °F (25 °C).

The condition of the Form 6 NX-T control battery can be determined by using the Battery Test function in the BATTERY MENU. No external current/voltage meter is necessary for testing.

#### Alarm Conditions:

- During a manual battery test a 5 Ω, 55 watt resistor is placed across the battery terminals for approximately 5 seconds. The Form 6 NX-T control measures the battery voltage, if the voltage drops below 22.8 VDC for one full second, the ALARM LED (battery alarm) is illuminated.
- When the Form 6 NX-T control is disconnected from AC power and the control battery drops below 23.5 VDC for 60 seconds, the ALARM LED will illuminate. If the battery voltage continues to decay and drops below 22 VDC, the Form 6 NX-T control will shut down.

**Note:** The battery test is blocked for 30 seconds upon power up of the control.

**Note:** AC power can be either connected or disconnected for battery test.

**Note:** If the battery voltage drops below 19 V, the battery must be charged by the external battery charger KA43ME7001.

1. Press the MENU button on the front panel.
2. Using the down arrow key, navigate to the BATTERY menu and press ENTER.
3. Using the down arrow key, navigate to the TEST BATTERY menu and press ENTER.
4. Press the F4 button to test the battery. The battery test results will display in the battery metering menu.

**Note:** Voltage should be between 25–31 VDC with the higher voltage at colder temperatures.

Under normal conditions, with AC connected and a fully charged battery, the charging current should be less than 20 mA.

With AC connected and a discharged battery, the current range should be between 20 and less than 450 mA. Current of 450 mA or greater indicates a problem with the charging circuit on the pole-mount power supply.

With AC disconnected and the battery supplying the load, current will read -400 to -600 mA depending on connected accessories.

### Test procedure for uninstalled battery

The entire process should be conducted in a clean environment, such as a repair shop.

Refer to **Table 9** and follow this procedure to perform a bench test on a control battery in a service shop:

1. Remove the control from service. Refer to **Remove the control from service** procedure within the **Testing** section of this manual.
2. Remove the battery from the control and carefully transport it to a suitable service facility.
3. Measure battery voltage.
4. Apply test load and measure battery voltage after 5 seconds of load to determine voltage drop. Refer to **Table 9** for Bench Test Load Condition.
5. Remove test load.

If the battery fails the test or is at least four years old, it should be replaced. Refer to **Table 9** for battery catalog part number.

### Battery charging

If it is not possible to charge the battery with the control's built-in charger, a KME5-60-1 (120 VAC) portable bench type battery charger kit is available, which includes the KA43ME7001 Battery Charger (**Figure 38**) and the KME5-325-1 Adapter Cable. Refer to *S280-79-14 KA43ME7001 Portable Lead Acid Battery Charger Instructions* for additional information.

**IMPORTANT**

Do not attempt to charge a lead acid battery below 2 VDC with the KA43ME7001 charger. The charger requires a minimal voltage to sense a battery is connected.

If the lead acid battery is below 19 VDC for over 2 days, replace the battery. The expired battery should be disposed of in an environmentally responsible manner. Consult local regulations for proper battery disposal.

**Table 9. Control battery bench testing and replacement information**

Control type	Battery catalog part #	Voltage	Type	Amp/hour	Bench test load condition for 5 sec.	Acceptable voltage drop at end of test load
Form 6 NX-T (high capacity)	KME5-134-1	24 v (two 12 v batteries)	Lead Acid	13	5 Ω 55 watt	2 v or less

Charge the battery with a KA43ME7001 (120 VAC) portable charger as follows:

- Form 6 Pole-mount Recloser Control (High Capacity)
  - Use adapter KME5-325-1 to connect the two 12 volt batteries to the KA43ME7001 charger.

**IMPORTANT**

Never connect a single 12 volt battery to the KA43ME7001 charger. Use adapter KME5-325-1 with the battery assembly when connecting the charger to the two 12 volt batteries.

**Note:** A yellow LED indicator on the body of the charger illuminates when charging. A green LED indicator illuminates when the charge is complete.

The charger senses when the battery voltage reaches 2.27 volts per cell, then the charge rate reduces to maintain a trickle charge.

The yellow LED flickers to indicate the battery has reached a full charge. This process can take up to 24 hours.

Refer to **Table 10** for additional battery charging accessories.

**Table 10. Battery charging accessories**

Description	Catalog Number
120 VAC Battery charger accessory	KME5-60-1



**Figure 38. KA43ME7001 battery charger**

**Return the control to service**

**CAUTION**

**Equipment misoperation. Do not connect this control to an energized recloser until all control settings have been properly programmed and verified. Refer to the programming information for this control. Failure to comply can result in control and recloser misoperation, equipment damage, and personal injury.**

G110.3

After the required work is completed, disconnect the control from the test set and follow this procedure to return the control to service:

1. While still in service shop, appropriate personnel must verify that all control settings are correct.
2. Reconnect the ground cable to the control.

**IMPORTANT**

Equipment misoperation. Disconnect all control power sources prior to disconnecting or reconnecting the control cable from the control. Failure to comply can result in recloser misoperation at the time of disconnection or reconnection of the control cable to the control.

T311.1

**IMPORTANT**

Prior to reconnecting the control cable, verify the control was removed from service in the exact order specified in the Remove the control from service section of this manual.

3. Control cable properly connected and supported.
4. Plug in the control battery.

**Note:** The Form 6 NX-T recloser control will not power up until AC power is applied.

**CAUTION**

**Equipment misoperation. Verify that the 120/240 VAC selector switch is correctly set for incoming voltage. Failure to comply may cause misoperation (unintentional operation) of the control and/or equipment damage resulting in personal injury.**

T278.0

5. Verify the selector switch on the Power Supply/Battery Charger Board is set to the correct position based upon the incoming power supply:
  - For 120 VAC incoming power, the selector switch must be set to the 115 V position.
  - For 240 VAC incoming power, the selector switch must be set to the 230 V position.
6. Apply AC power to the control.
7. Disable GND TRIP BLOCKED.
  - a. Press the CHANGE button on the Operator Panel to enter the CHANGE mode.
  - b. Depress the GND TRIP BLOCKED button within ten seconds after entering the CHANGE mode.

**Note:** Once selected (or after ten seconds), the control returns to normal operation.

8. Verify the control clock is set to the current time after AC power has been reapplied.

**Note:** The control clock may require resetting if the operating power has been disconnected for more than thirty days. Refer to the *Form 6 NX-T Programming Guide* for information on setting the control clock.

**Additional information****CAUTION**

**This equipment requires routine inspection and maintenance to ensure proper operation. If it is not maintained, it can fail to operate properly. Improper operation can cause equipment damage and possible personal injury.**

G105.1

**Replacement kits**

Replacement kits for the Form 6 NX-T pole-mount control are available through the factory Service Department. To order these kits, refer to the Replacement Parts price list for catalog numbers and pricing. Contact your Eaton representative for additional information and order procedures.

**Factory-authorized service centers**

Factory-authorized service centers are located throughout the continental United States to provide maintenance, repair and testing services for Eaton Cooper Power series controls and reclosers. For further information, contact your Eaton representative.

**Factory maintenance classes**

The factory service department offers a basic testing and troubleshooting course for the Form 6 NX-T recloser control. This course, taught by experienced service technicians, is held at the factory's in-house training facility. For additional information, contact your Eaton representative.



**Eaton**  
1000 Eaton Boulevard  
Cleveland, OH 44122  
United States  
Eaton.com

**Eaton's Power Systems Division**  
2300 Badger Drive  
Waukesha, WI 53188  
United States  
Eaton.com/cooperpowerseries

© 2018 Eaton  
All Rights Reserved  
Printed in USA  
Publication No. MN280088EN  
KA2048-0752 REV 01  
June 2018

Eaton is a registered trademark.

All trademarks are property  
of their respective owners.

For Eaton's Cooper Power series product  
information  
call 1-877-277-4636 or visit:  
[www.eaton.com/cooperpowerseries](http://www.eaton.com/cooperpowerseries).