

15 kV motor starter AMPGARD



Contents

Description	Page
General description	
Application	2
Features	2
Personnel safety features	2
Mechanical non-loadbreak isolating switch	3
Type SL 15 kV vacuum contactor	4
Current-limiting fuses	5
Contactor-fuse coordination	5
Protection considerations	6
Isolated low voltage control	7
Bus and optional features	8
Reduced voltage starter and reduced voltage autotransformer starter.	9
Synchronous motor, brush type solid-state soft sync field control	10
Incoming line	10
Technical data	
Schematic diagrams	11
Type SL 15 kV vacuum contactor ratings and specifications	13
Layout dimensions	14



Powering Business Worldwide

General description

Application

Eaton's 15 kV AMPGARD® medium voltage metal-enclosed control family provides control and protection of medium voltage motors and equipment rated 10,000V to 13,800V nominal/15,000V maximum.

AMPGARD control has a complete metal-enclosed offering: full and reduced voltage starting of medium voltage motors up to 7500 hp.

Features

Personnel safety: Positive mechanical isolating switch with visible disconnect completely grounds and isolates the starter from the line connectors with a mechanically driven isolating shutter, leaving no exposed high voltage. Medium voltage door is mechanically locked closed with the disconnect; low voltage section has separate door and is segregated from the medium voltage section.

Ease of installation: Current-limiting fuses, contactor assembly, and isolating switch assembly are easily removed from the enclosure; line and load terminals are completely accessible from the front.

Ease of maintenance: All components are front accessible, facilitating routine inspection and/or parts replacement. The low voltage compartment is painted white as standard to maximize serviceability.

Simplicity of design: Component-to-component design eliminates half of the electrical connections.

Time-proven contactor technology: Long-life vacuum contactors with stab-in connections.

High degree of isolation: Main bus is located in a separate compartment on top of lineup. Vertical bus is barriered in rear of starter and auxiliary compartments. A vertical low voltage wireway is provided for isolation of customer control wiring. The low voltage control compartment is isolated from medium voltage by steel barriers.



15 kV AMPGARD Motor Control Assembly

Starter catalog types are available for the following applications:

- Squirrel cage, full voltage
- Squirrel cage, primary reactor
- Squirrel cage, autotransformer
- Synchronous full voltage
- Synchronous primary reactor
- Synchronous autotransformer

Personnel safety features

One of the most important considerations in designing the Eaton 15 kV AMPGARD starter was personnel safety. The result is an extensive system of interlocks and other safety features.

Interlocks

Interlocking on 15 kV AMPGARD starters includes:

- Isolating switch mechanism locks the medium voltage door closed when the switch is in the ON position
- Provision for optional key interlocks
- When door is open, interlock prevents operating handle from being moved inadvertently to the ON position
- When contactor is energized, isolating switch cannot be opened or closed

Other safety features

15 kV AMPGARD starters include many additional features designed to protect operating personnel. These features include:

- Provision for a padlock on the isolating switch handle in the OFF position
- Shutter barrier between line terminals and isolation switch stabs is mechanically driven
- Distinctive marking on back of switch assembly appears when shutter barrier is in position and starter is completely isolated from the line
- Grounding clips provide a positive grounding of the starter and main fuses when the isolating switch is opened
- High and low voltage circuits are compartmentalized and isolated from each other
- The drawout isolation switch is easily removed by loosening two bolts in the back of the switch; the shutter remains in place when the switch is withdrawn

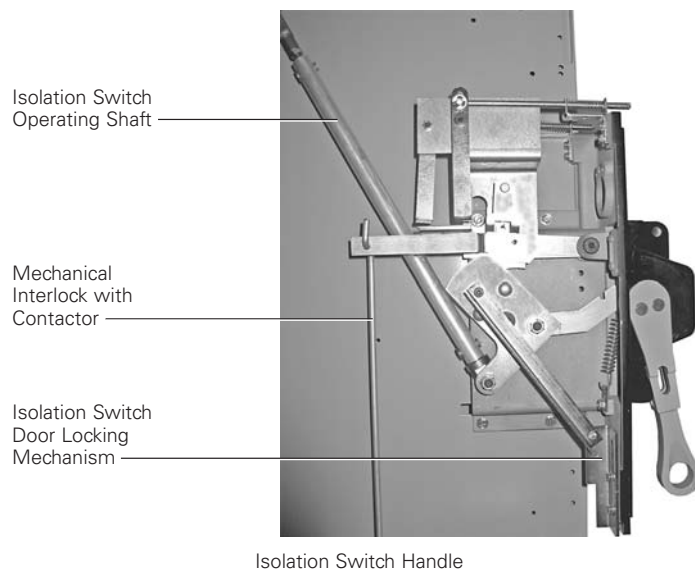

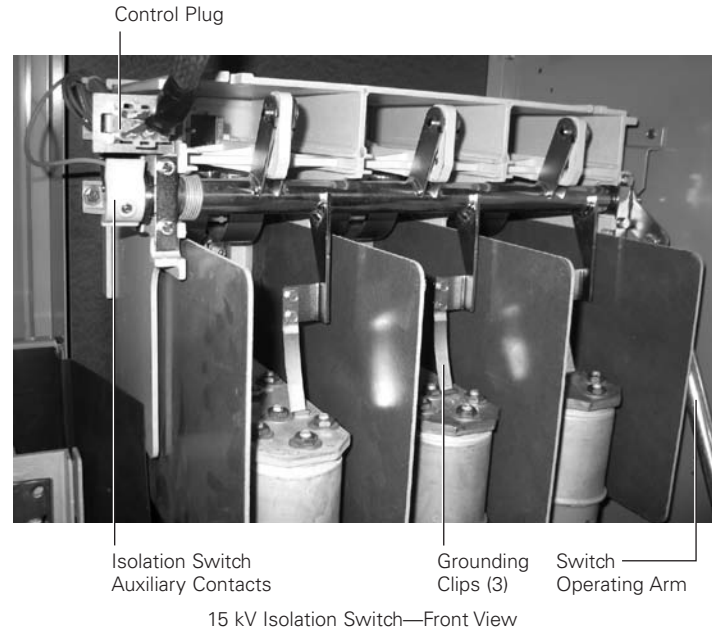
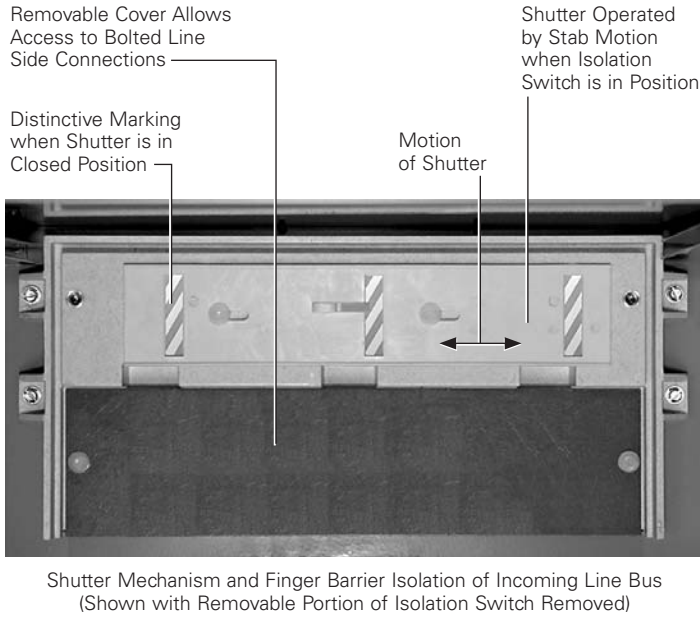

Mechanical non-loadbreak isolating switch

Isolation switch description

Eaton's Type JMT 15H is a drawout, lightweight, three-pole, manually operated isolating switch mounted in the top of the starter enclosure. It may be easily removed by loosening two bolts in the rear of the switch. The JMT 15H is rated 300A continuous.

The component-to-component circuitry concept includes the mountings for the current-limiting fuses as part of the isolating switch.

A positive mechanical interlock between the isolating switch handle mechanism and contactor prevents the isolating switch from being opened or closed when the contactor is closed.

An operating lever in the isolating switch handle mechanism is designed to shear off if the operator uses too much force in trying to open the non-loadbreak isolating switch when the contactor is closed. This feature ensures that the operator cannot open the switch with the main contactor closed, even if excessive force is used on the operating handle.

To operate the isolating switch, the operating handle is moved through a 180° vertical arc from the ON to the OFF position. In the ON position, an operator on the back of the handle housing extends through a bracket on the rear of the starter high voltage door, preventing the door from being opened with the switch closed. When the high voltage door is open, a door interlock prevents the handle from being inadvertently returned to the ON position.

When the operating handle is moved from ON to OFF, copper stabs are withdrawn from incoming line fingers. As the stabs withdraw, they are visible above the top of the fuses when viewed from the front, and simultaneously grounded. As the fingers are withdrawn, a spring-driven isolating shutter moves across the back barrier to prevent front access to the line connections. As the shutter slides into position, distinctive markings appear on the back barrier, making it easier to check the position of the shutter. Refer to **Page 5** for an illustration of this feature.

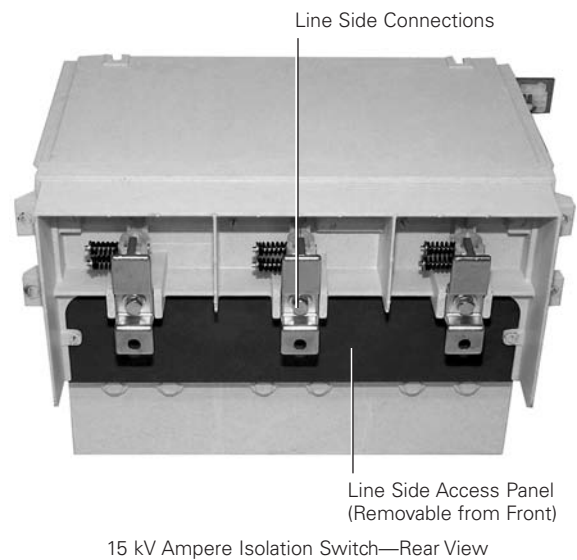

Switch Handle Closed



Switch Handle Open

Type SL 15 kV vacuum contactor

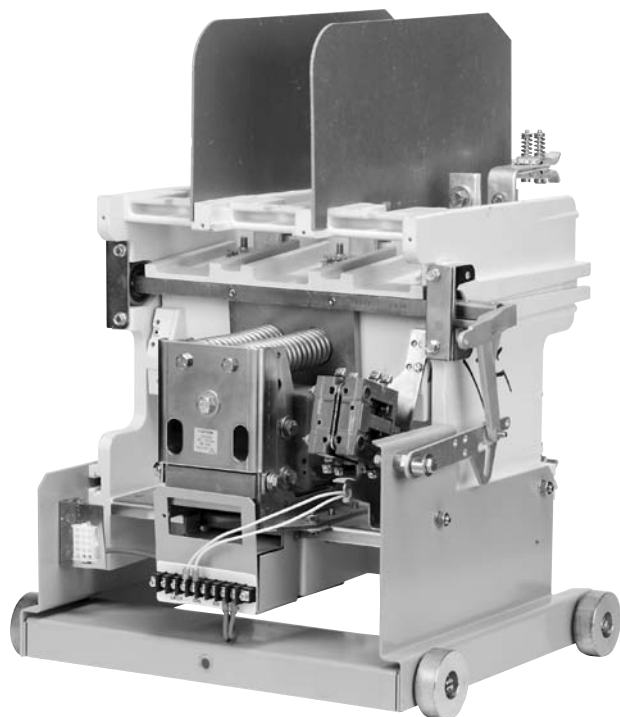

15 kV SL Contactor

Eaton's AMPGARD Type SL vacuum contactors were designed and engineered specifically for use in AMPGARD starters. They are self-supporting, compact, drawout, three-pole, DC magnet closed contactors. 15 kV SL contactors are available in the standard stab-in design.

Design

Eaton's AMPGARD vacuum contactors are highly versatile, low-chop contactors that have been designed to meet all applicable NEMA® standards and are UL®-recognized components. The contactors accommodate mechanical interlocks, which function with the starter isolation switch and with other contactors. These interlocks provide unmatched safety and service protection.

The contactors consist of a molded frame with moving armature, magnet, and vacuum interrupters. The contactor is easily positioned into the starter, and long-life vacuum interrupters provide many operations with a minimal maintenance program. The SL operating coils are energized by a control board, which provides a pulse-width-modulated DC output. Control voltages and contactor dropout times are programmed using a DIP switch located on the control board. The control board is mounted in a protected cavity in the contactor frame to prevent inadvertent access to the voltage and dropout DIP switch. Four auxiliary contacts (2NO, 2NC) are supplied with each contactor and are wired to terminal blocks on the starter control panel.

The vacuum interrupters employ special main contact materials that exhibit a low-chop current plus other specially engineered characteristics that minimize switching surges. Surge protection is therefore not required due to the use of the vacuum contactor. Surge protection may be required for other reasons, such as the high probability of lightning strike, for example.

Maintenance

Reduced maintenance is one of the outstanding features of the Eaton AMPGARD vacuum contactor line. The special contact material in the vacuum interrupters provides long life even under severe operating conditions. The main coils operate with a very low temperature rise to maximize insulation life. Steel bearings on the main shaft provide long, trouble-free operation.

A simple go/no-go gauge is used for checking contact wear. Wear can be checked without removing the contactor from the starter. The vacuum contactor is much lighter than previous generation airbreak or vacuum contactors, allowing for easier insertion and removal from the starter structure.

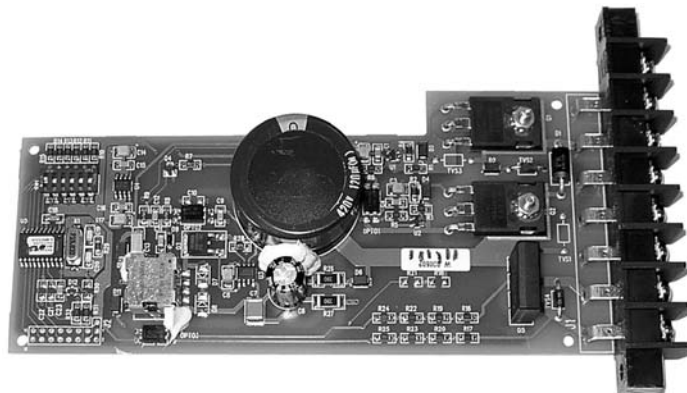

Contactor Control Board

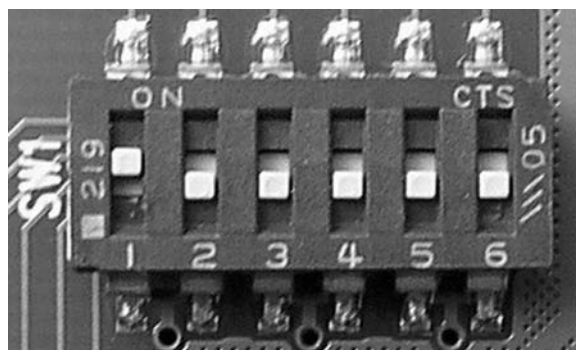

DIP Switch on Contactor Control Board

Current-limiting fuses

15 kV AMPGARD starters use Eaton Type 15BHCLS power fuses. The fuse is coordinated with the contactor and overload relay characteristics to provide maximum motor/transformer utilization and protection. The standard mounting method for power fuses is bolted.

Interruption is accomplished without expulsion of gases, noise or moving parts. Type 15BHCLS fuses are mounted in a vertical position to ensure maximum rating reliability, proper operation and to eliminate the possibility of dust and dirt collecting, resulting in a deterioration of dielectric properties. When a fault has been cleared, an indicator in the top of the fuse, normally depressed, pops up to give visible blown fuse indication.

The control circuit primary fuses are also current-limiting. Blown fuses may be removed and replaced without removing or drawing out the contactor.



15BHCLS Bolted Fuse—Standard

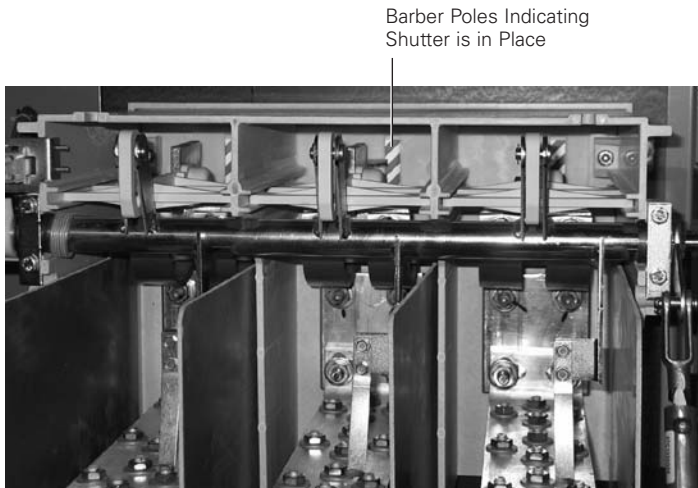

Shutter Position Indicators

Contactor–fuse coordination

The AMPGARD starter provides ensured coordination between its fuses, contactor, current transformers, protective relays, and the motor it is controlling.

One of the most critical coordination issues is between the contactor and the starter fuses. The fuses must interrupt faults greater than the interrupting rating of the contactor. The AMPGARD 15 kV contactor has an eight-cycle dropout time factory setting as standard and will interrupt 5000A. The maximum size fuse used with the 15 kV contactor is 400A. By comparing the fuse curve with the contactor rating, it can be observed that for faults greater than 5000A, the fuse will open before the contactor. With faults less than 5000A, the contactor may clear the fault before the fuse blows, depending on the settings of the protective relays. Refer to **Figure 1** for an illustration of AMPGARD coordination.

Other vacuum contactors available today may have lower interrupting ratings than the AMPGARD Type SL vacuum contactors. Dropout times also vary, and may be as short as two cycles on other starter designs. Lower interrupting ratings and shorter dropout times can result in fault current levels where the contactor may be required to interrupt a fault greater than its rating. This can result in equipment failure. Refer to **Figure 2** for an illustration of an improperly coordinated starter.

AMPGARD starters also ensure coordination between other starter components. The current transformers and protective relays are selected to work properly with each other, and to protect the motor. Protective relays, like the Eaton EMR family of relays, provide optimal motor protection while also rapidly opening the contactor during fault conditions. This rapid opening signal cannot open the contactor in less than its set dropout time, but it will take the motor off-line in the shortest possible time. This will help minimize mechanical damage to the motor and may prevent the starter fuses from blowing by allowing the contactor to clear the fault (only if the fault is less than the contactor interrupting rating).

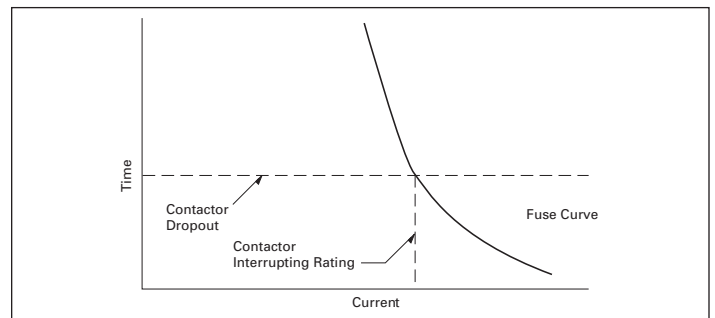

Figure 1. Proper Contactor–Fuse Coordination Found in AMPGARD Starter

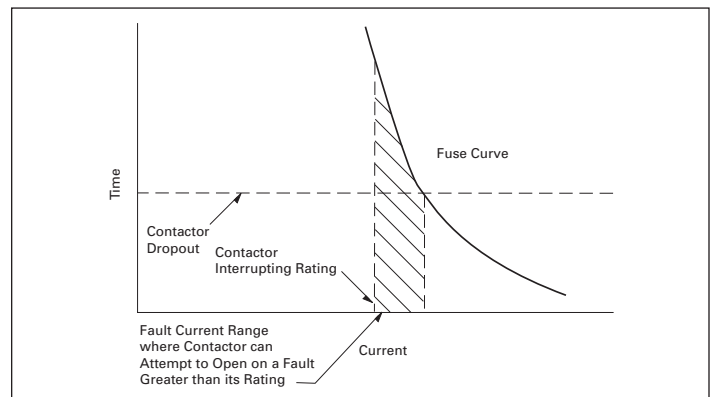

Figure 2. Contactor Fuses that are not Properly Coordinated

Effective August 2012

Protection considerations

Coordinated with the motor's characteristics, the protective devices in Eaton's AMPGARD starter provide motor protection from overload to full system capacity faults. AMPGARD starters are supplied with an adjustable thermal overload relay as standard. The overload relay is designed to protect the motor from sustained overloads. An Eaton GroundGard relay is an available option for protection from ground faults. The factory setting for the GroundGard will initiate a starter trip at approximately 7A ground current.

Multi-function solid-state motor protection relays are a common option on AMPGARD starters. The Eaton EMR-3000, EMR-4000, or EMR-5000 is typically provided when a multi-function relay is specified. The EMR family of relays provides many types of protection, including overload, locked rotor, ground fault, and phase loss/phase unbalance. The EMR family also provides start control logic to protect the motor against excessive starting. The relay may be applied to either across-the-line or reduced voltage starters. On reduced voltage starters, the EMR family can control the transition from reduced to full voltage, offering the greatest protection for the motor and starter. An optional RTD module can be supplied for motors with built-in RTDs.



EMR-5000 Motor Protective Relay

InsulGard™ relays are an available option on AMPGARD starters. The InsulGard provides early warning of increasing partial discharge levels in the starting equipment, cables, and motor. This early warning will help the user to better schedule maintenance and avoid unplanned downtime.



Low Voltage Door with InsulGard Relay

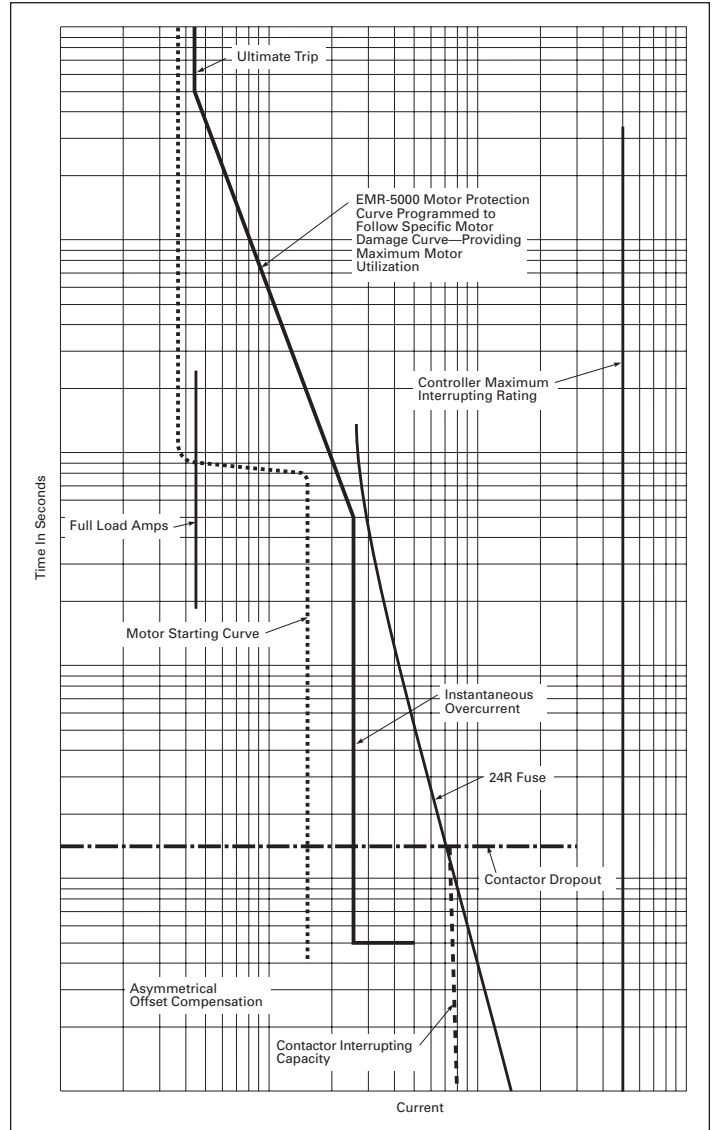
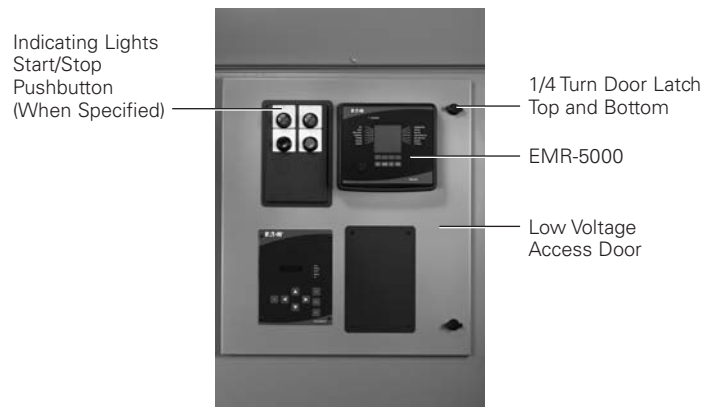

Figure 3. Full Range Coordinated Protection Between Current-Limiting Type CLS Fuses, Vacuum Contactor, and Motor Protection Relay

Isolated low voltage control

The low voltage door has four cutouts as standard.



AMPGARD 15 kV Starter Door Closed

Distinctive markings on isolation switch shutter indicate shutter is closed and switch is open.



View of Isolation Switch Through Viewing Window



15 kV AMPGARD Starter—Medium Voltage Door Open

The low voltage control panel is behind the low voltage door and is completely isolated from the medium voltage compartment. A standard viewing window allows visual verification of the isolation switch status before attempting to open the medium voltage door. The medium voltage door is locked closed whenever the isolation switch is closed.

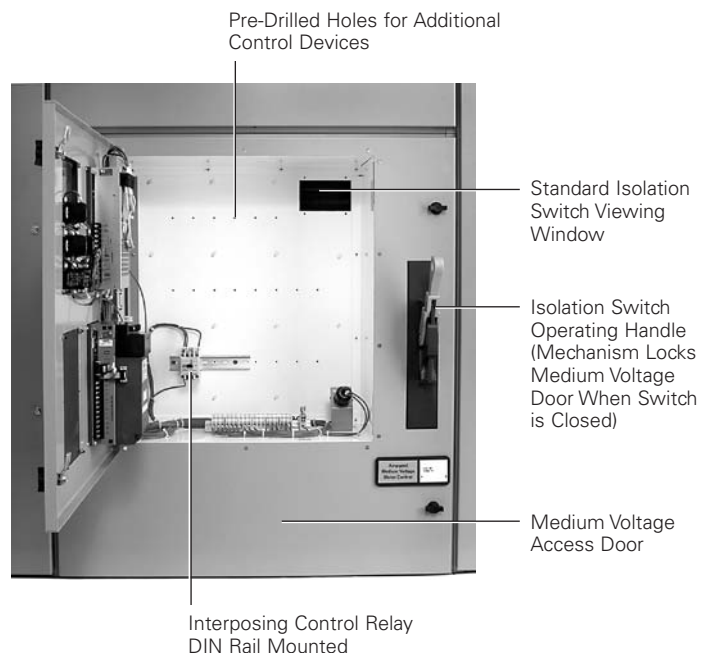

AMPGARD 15 kV Starter—Low Voltage Door Open

Bus and optional features

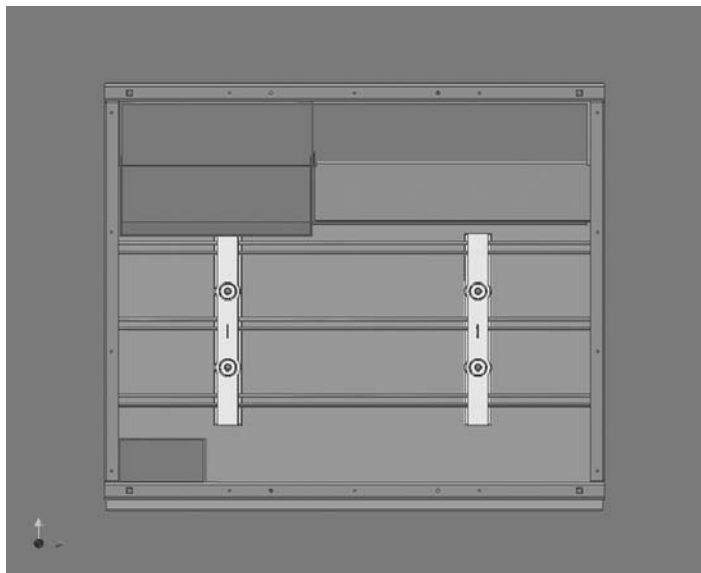

Bus Compartment Top View 2000A Main Horizontal Bus

Main bus

When starters are grouped together in a lineup, a typical option is the main bus. Eaton's 15 kV AMPGARD main bus is mounted in its own 12.00-inch-high (304.8-mm-high) enclosure, which isolates it from the starter. The connection from the main bus to the starter is done with rigid vertical bus. Insulated barriers are provided for separate top entry of power and control cables. The main bus is top-, side-, and front-accessible, which allows for ease of maintenance or extension of lineup without disassembling the starters.

Main bus is available for 1000A, 1200A, and 2000A. Main bus is insulated as standard. Bus may be supplied with either tin or silver plating.

The standard bus short-circuit rating is per NEMA standards and is based on the let-through current of the largest fuse used in any starter. An optional 50 kA, two second bus rating is available for customers that require a higher rating for the main bus.

Vertical bus

Vertical bus is located behind a fixed barrier in the rear of the enclosure. It is fully insulated as standard, with plating to match that of the main bus.

UL and CSA certification

15 kV AMPGARD starters are designed, assembled, and tested to meet all applicable standards: NEMA/ANSI ICS3, UL 347, CSA® C22.2 No. 14, and IEC 60470. The major components, i.e., contactor, isolating switch, fuses, and EMR-3000/4000/5000, are UL recognized.

UL or CSA labeling of a specific starter requires review to ensure that all requested modifications and auxiliary devices meet the appropriate standards. Refer to factory when specified. AMPGARD starters meet the requirements of IEC standard 62271-106.

Seismic certification

AMPGARD starters are seismically tested, seismically qualified, and exceed requirements of both the International Building Code® (IBC) and California Building Code Title 24. Seismic-certified starters require the use of special keyed door latches on the medium voltage doors to ensure that the doors do not open during a seismic event. No other special modifications are required.

Other optional features

AMPGARD starters are available with a variety of accessories and modifications to satisfy a wide range of application requirements. Some of the broad areas covered include:

- Bus and cable entrance enclosures
- Transformers
- Power factor correction capacitors
- Operators and pilot devices
- Instruments and meters
- Control relays and timers
- Solid-state or selected electromechanical protection devices



Vertical Bus—Rear View

Reduced voltage starter

Eaton offers traditional electromechanical reduced voltage starters in addition to full voltage starters. Unless otherwise specified, reactors and autotransformers are NEMA medium-duty rated. They are designed for three 30-second starters per hour. Heavy-duty reactors and transformers can be supplied when specified. Locked rotor current must be specified when ordering reduced voltage starters to ensure that the reactors or autotransformers are properly sized.

Reduced voltage reactor starter

Table 1. Type 502 Reactor Starting Characteristics

Starter Type	% Motor Voltage	% Motor Current	% Line Current	% Torque
80% Tap	80	80	80	64
65% Tap ①	65	65	65	42
50% Tap	50	50	50	25

① Factory set on 65% tap.

Advantages

- Reduces starting currents
- Least costly reduced voltage starting method

Disadvantages

- Large footprint: three structures
- “Bump” on transition to full voltage
- Not as efficient as autotransformer
- Due to reduced torque during starting, motor must typically be unloaded during the start sequence

Sequence of operation

- Main contactor (M) closes
- Current flows through reactor, reducing voltage to motor (based on tap setting)
- When motor current reaches ~125%, the run contactor (R) closes, providing full voltage to the motor

Reduced voltage autotransformer starter

Table 2. Type 602 Autotransformer Starting Characteristics

Starter Type	% Motor Voltage	% Motor Current	% Line Current	% Torque
80% Tap	80	80	67	64
65% Tap ①	65	65	45	42
50% Tap	50	50	28	25

① Factory set on 65% tap.



Autotransformer Starter

Advantages

- Produces the most torque per incoming line ampere of any reduced voltage starting method
- Less costly than RVSS

Disadvantages

- Large footprint: three structures
- More costly than reactor
- “Bump” on transition to full voltage
- Due to reduced torque during starting, motor must typically be unloaded during the start sequence

Sequence of operation

- Shorting contactor (S) closes
- Main contactor (M) closes
- Current flows through autotransformer, reducing voltage to motor (based on tap setting)
- When motor current reaches ~125%, the shorting contactor (S) opens and the run contactor (R) closes, providing full voltage to the motor

Note: Because the motor is never disconnected from the supply voltage, the starting is closed transition.

Synchronous motor, brush-type solid-state soft sync field control

The brush-type synchronous motor starter includes the basic synchronous control, and the protection panel is a separate 36.00-inch-wide (914.4-mm-wide) enclosure.

The step down static excitation transformer is connected to the load side of the main contactor and is protected by its own current-limiting fuses.

The static exciter is an SCR type. Its DC voltage output is adjustable via door-mounted potentiometer. Minimum setting is 50% of rated voltage.

The synchronous control board monitors the induced field during acceleration and energizes the DC rotor field at the optimum speed and rotor-stator pole relationship.

Solid-state, brush-type synchronous motor control includes the following protective features:

- Locked rotor protection
- Incomplete sequence
- Failure to synchronize
- Fuse failure
- Pullout protection
- Field loss protection

The motor windings are protected by the conventional induction motor control protection (thermal, EMR-5000).

When ordering, you must specify:

- DC exciter field amperes
- DC exciter field volts
- Maximum induced field current rms at start (starting and discharge resistor amperes)
- Starting and discharge resistor ohms

Note: Maximum induced field current multiplied by starting and discharge resistor ohms must be less than 1500 volts to prevent damage to starting equipment and motor.

Incoming line

Depending on the size and number of incoming cables, an incoming line enclosure may be necessary. Different designs are available for incoming power for top or bottom entry.

The addition of incoming line metering requires a 36.00-inch-wide (914.4-mm-wide) structure in lieu of a 24.00-inch-wide (609.6-mm-wide) structure.

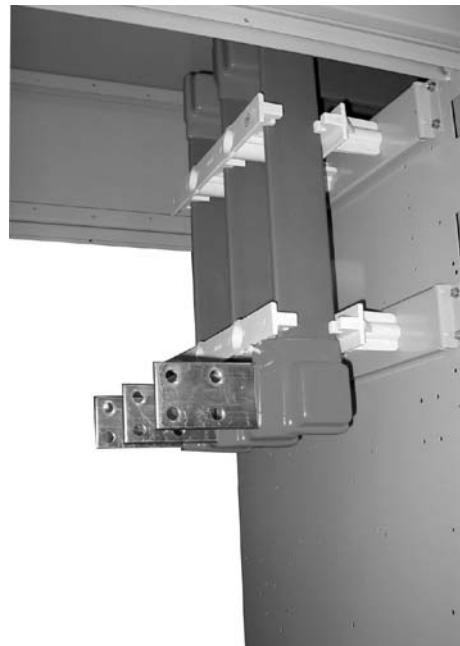

Typical 24.00-Inch-Wide (609.6-mm-Wide) Incoming Line Structure

Technical data

Typical schematic diagram for full voltage FVNR starter

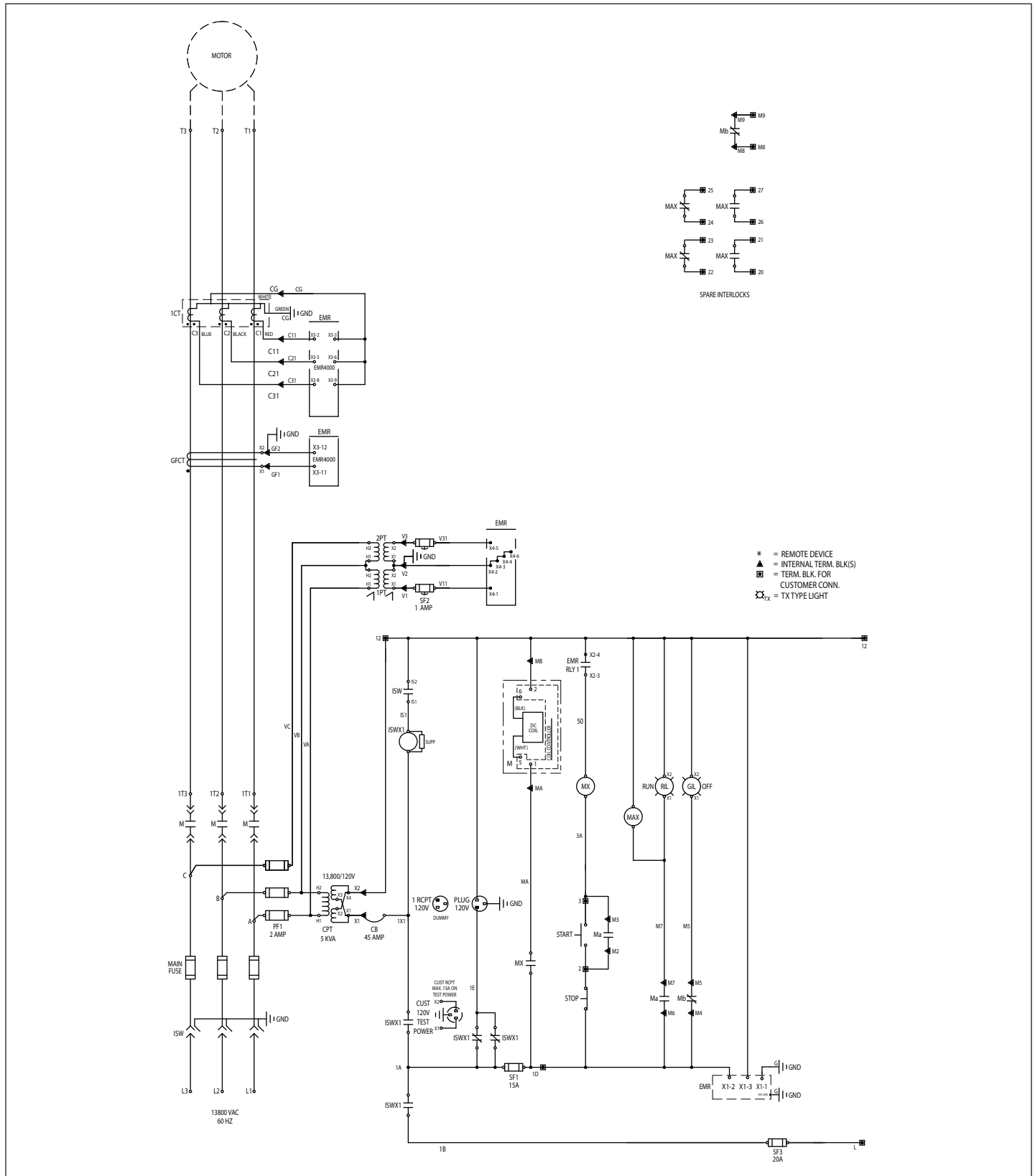

Figure 4. Induction Motor Across-the-Line Starter Vacuum Contactor with Optional EMR-4000 Motor Protection and Metering, Start-Stop Pushbuttons, and Red and Green Indicating Lights

Technical data (continued)

Typical schematic diagram for reduced voltage autotransformer RVAT starter

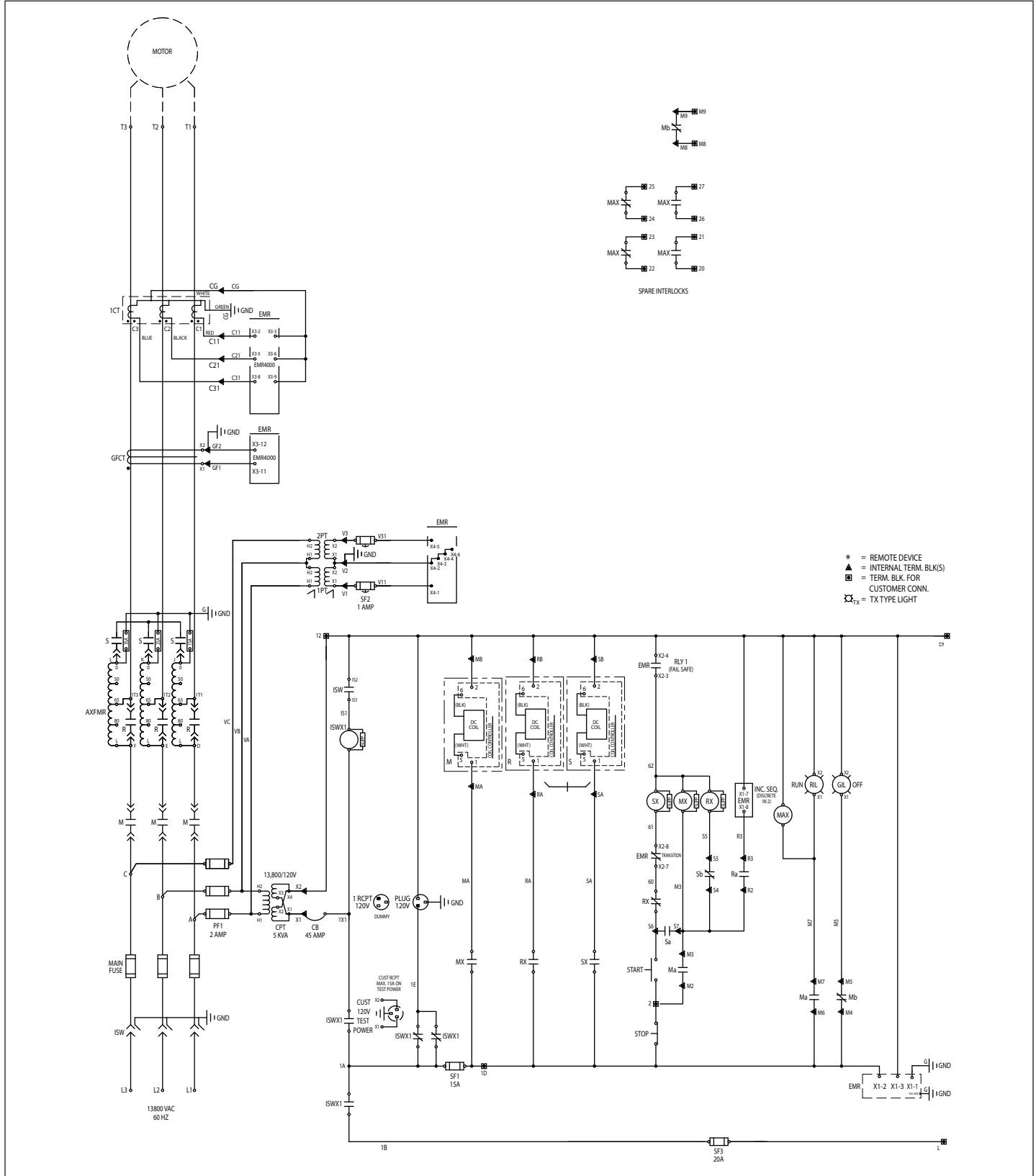

Figure 5. Induction Motor Reduced Voltage Autotransformer Starter, Vacuum Contactor with Optional EMR-4000 Motor Protection and Metering, Start-Stop Pushbuttons, and Red and Green Indicating Lights

Table 3. Type SL 15 kV Vacuum Contactor Ratings

Description	SL12V230	SL15V230
Utilization voltage	10,000–11,000V	12,400–13,800V
Interrupting rating		
E1 (unfused)	5 kA	5 kA
E2 (fused)	950 MVA at 11,000V	1,190 MVA at 13,800V
E2 (fused)	50 kA	50 kA
Induction motor	6000 hp (300 FLA)	7500 hp (300 FLA)
Synchronous motor (0.8 PF)	6000 hp	7500 hp
Synchronous motor (1.0 PF)	6750 hp	8500 hp
Transformer	5400 kVA at 11 kV	6800 kVA at 13.8 kV
BIL	75 kV	95 kV (with arrestors)

Table 4. Type SL 15 kV Vacuum Contactor Specifications

Specification	Rating
Maximum voltage	15,000V
Maximum interrupting current (3 operations)	5000A
Rated current	
Enclosed	300A
Open	300A
IEC make-break capability	AC3—Make 2560 AC3—Break 2560
Short time current	
30 seconds	1800A
1 second	4500A
8.75 ms	25 kA Peak
Mechanical life	1 million operations
Electrical life	100,000 operations
Dielectric strength (60 Hz)	36 kV (1 minute)
Closing time	80 ms
Opening time	130–330 ms (selectable)
Weight	95 lbs (43 kg)
Arcing time	12 ms (3/4 cycle) or less
Pickup voltage	80% rated coil voltage
Dropout voltage	60% rated coil voltage
Control voltages	
(AC)	110V/120V/220V/240V (50/60 Hz)
(DC)	125V
Control circuit burden (rated volt)	
Closing	2600 VA
Holding	80 VA
Auxiliary contact ratings	
Voltage (maximum)	600V
Continuous current	10A
Making capacity (AC)	7200 VA
Making capacity (DC)	200 VA
Breaking capacity (AC)	720 VA
Breaking capacity (DC)	200 VA
Latch (when specified)	
Mechanical life	250,000 operations
Trip voltages (DC)	24V/48V/96V
Trip voltages (AC)	110V/220V (50/60 Hz)
Tripping voltage	80% rated coil voltage
Tripping Burden	
24 Vdc	1200 VA
48 Vdc and 96 Vdc	400 VA
110 Vac and 220 Vac	500 VA

Layout dimensions

15 kV full voltage squirrel cage starters non-reversing

Equipment details

Mounted in the medium voltage section

- Three incoming line connectors
- Drawout three-pole gang-operated line isolating switch assembly with isolating shutter, external operating handle interlocked to prevent opening the medium voltage compartment door until the isolating switch is open and grounded
- Vertically mounted current-limiting power fuses with pop-up blown fuse indicators
- One magnetic three-pole vacuum contactor with DC operating coils and mechanical interlock to prevent opening the isolating switch when contactor is closed

- One control power transformer (115V secondary)
- Two CPT primary current-limiting fuses
- One control circuit secondary fuse
- One run-test circuit
- Four electrical interlocks (2NO, 2NC)
- Three current transformers

Mounted in the low voltage compartment

- Control panel with:
 - One EMR-5000 motor protection relay
 - One interposing control relay
- Set of control circuit terminal blocks

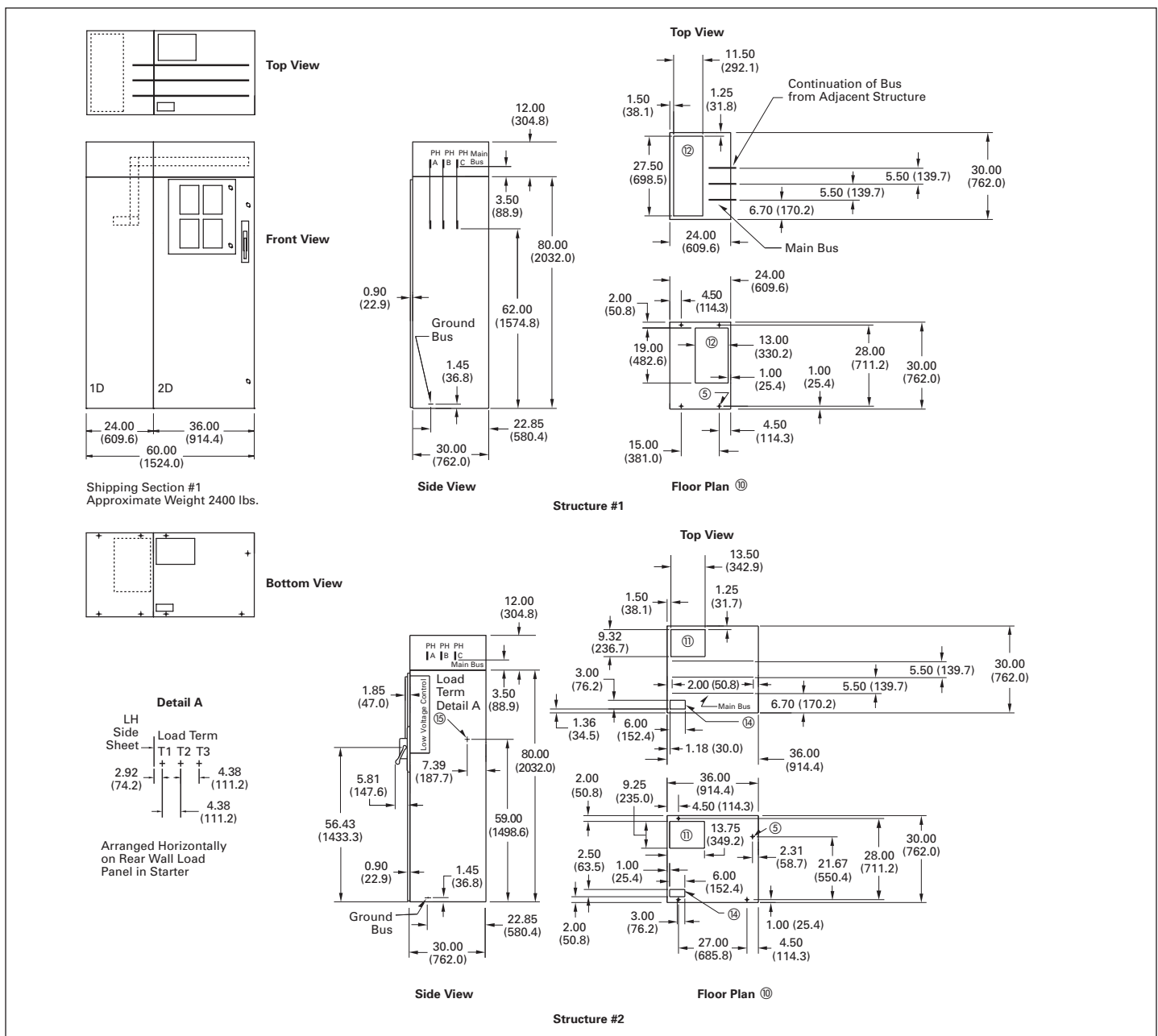

Figure 6. Arrangement 1 Detail (Full Voltage 15 kV)—See Table 5 on Page 18 for Notes

15 kV primary reactor, reduced voltage starters non-reversing*Mounted in the medium voltage section*

- Three incoming line connectors
- One drawout three-pole gang-operated line isolation switch assembly with isolating shutter, external operating handle interlocked to prevent opening the medium voltage compartment door until the isolating switch is open and grounded
- One vertically mounted current-limiting power fuse with pop-up blown fuse indicators
- One magnetic three-pole vacuum contactor with DC operating coils and mechanical interlock to prevent opening the isolation switch when the contactor is closed
- One control power transformer (115V secondary)
- Two CPT primary current-limiting fuses
- One control circuit secondary fuse
- One run-test circuit
- Four electrical interlocks (2NO, 2NC)

Mounted in the low voltage compartment

- One control panel with:
 - One EMR-5000 motor protection relay
 - Two interposing relays
- One set of control circuit terminal blocks

Reduced voltage structure

- One magnetic three-pole vacuum run contactor with DC operating coil and electrical interlocks
- Three current transformers
- One medium-duty starting reactor with 50–65–80% taps

Note: Structure is 40.00 inches (1016.0 mm) wide for locked rotor currents greater than 1200A.

15 kV autotransformer, reduced voltage starters non-reversing*Mounted in the medium voltage section*

- Three incoming line connectors
- One drawout three-pole gang-operated line isolation switch assembly with isolating shutter, external operating handle interlocked to prevent opening the medium voltage compartment door until the isolating switch is open and grounded
- One vertically mounted current-limiting power fuse with pop-up blown fuse indicators
- One magnetic three-pole vacuum contactor with DC operating coils and mechanical interlock to prevent opening the isolation switch when the contactor is closed
- One control power transformer (115V secondary)
- Two CPT primary current-limiting fuses
- One control circuit secondary fuse
- One run-test circuit
- Four electrical interlocks (2NO, 2NC)

Mounted in the low voltage compartment

- One control panel with:
 - One EMR-5000 motor protection relay
 - Two interposing relays
- One set of control circuit terminal blocks

Reduced voltage structure(s)

- One magnetic three-pole vacuum run contactor with DC operating coil and electrically and mechanically interlocked with the starting contactor
- One magnetic two-pole vacuum start contactor with DC operating coil and electrical and mechanical interlocks
- Three current transformers
- One medium-duty starting autotransformer with 50–65–80% taps
- Three distribution class lightning arresters for high voltage stress protection on the transformer zero tap

Note: Structure is 40.00 inches (1016.0 mm) wide for locked rotor currents greater than 1200A.

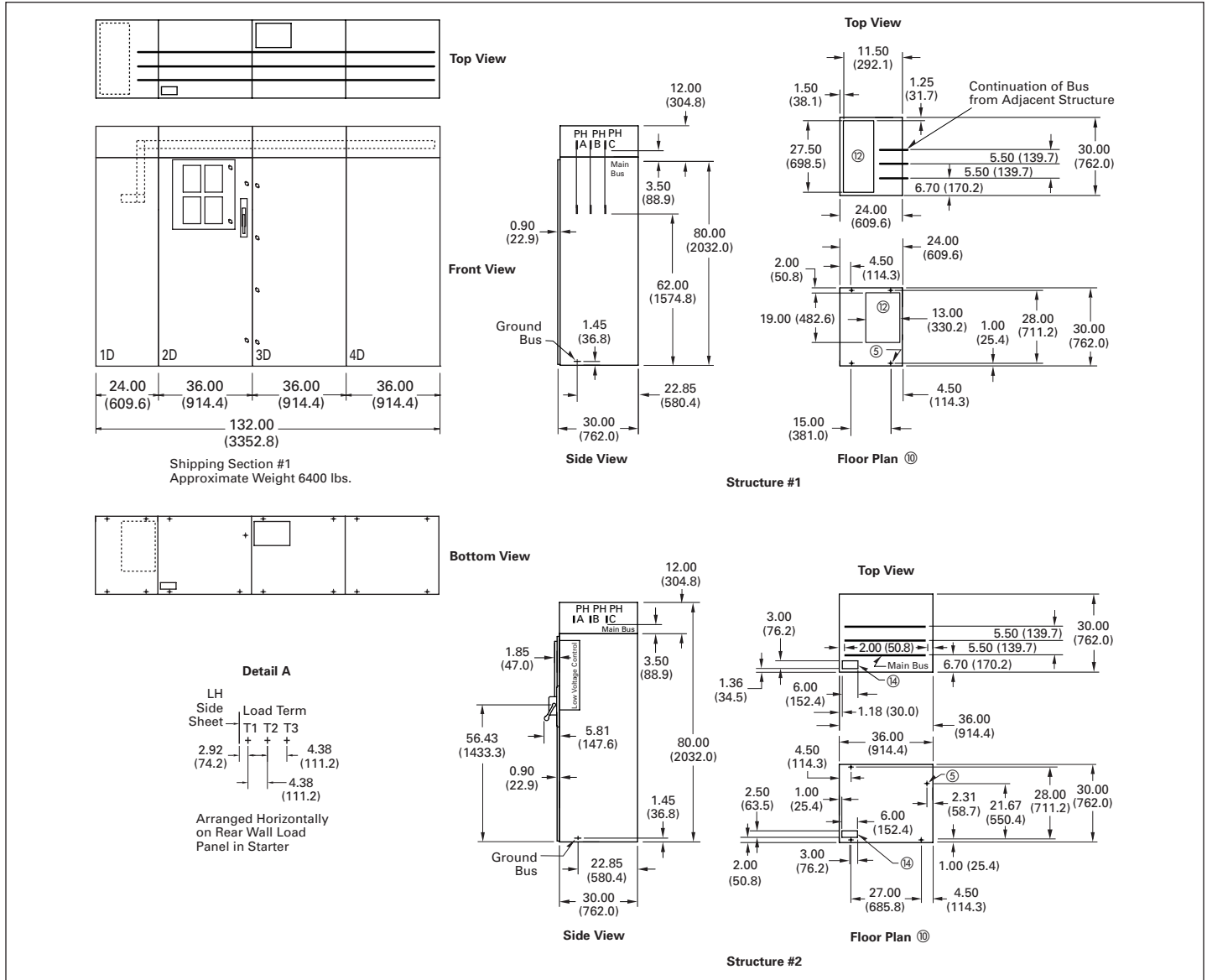

Figure 7. Arrangement 1 Detail (Reduced Voltage Reactor and Autotransformer, 15 kV)—See Table 5 on Page 18 for Notes

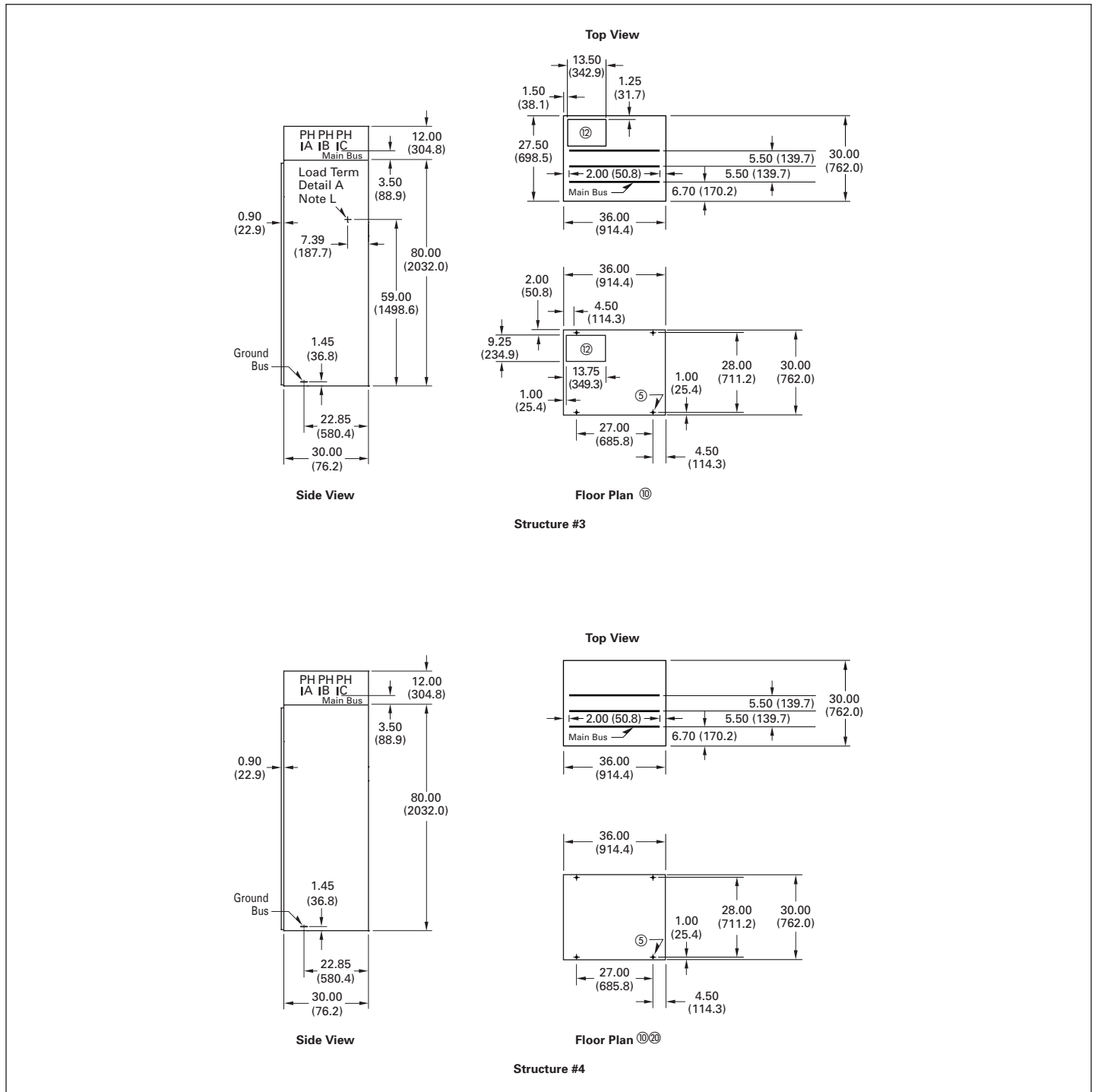

Figure 8. Arrangement 1 Detail (Reduced Voltage Reactor and Autotransformer, 15 kV) (continued)—See Table 5 on Page 18 for Notes

Table 5. Arrangement Detail Notes (Refers to Figures 6–8)

Cable Notes

- ① Line connection is designed for maximum of one 4/0 cable.
- ② Line connection is designed for maximum of two 500 kcmil.
- ③ Load connection is designed for maximum of one 350 kcmil.
- ④ Load connection is designed for maximum of one 750 kcmil.

Arrangement Notes

- ⑤ 0.875 dia. typical four holes. Mounting studs to extend a maximum of 2.00 inches (50.8 mm) above grade.
- ⑥ HV conduit space, load cables for two-high starters. Cables for lower starter enter in front half of conduit space, and cables for upper starter enter in rear half.
- ⑦ HV conduit space, line and load cables for bottom entry stand-alone starters. Line cables should enter in rear half of conduit space, and load cables should enter in front half of conduit space.
- ⑧ LV conduit space for two-high starters with bottom entry control conduit. Control wiring for upper starter should enter in left half of conduit space, and lower starter control wiring should enter in right half of conduit space.
- ⑨ LV conduit space for two-high starters with top entry control conduit. Control wiring for upper starter should enter in right half of conduit space, and lower starter control wiring should enter in left half of conduit space.
- ⑩ 90° door swing requires 12.00 inches (304.8 mm) for 12.00-inch-wide (304.8-mm-wide) structure, 18.00 inches (457.2 mm) for 18.00-inch-wide (457.2-mm-wide) structure, 24.00 inches (609.6 mm) for 24.00-inch-wide (609.6-mm-wide) structure, 36.00 inches (914.4 mm) for 36.00-inch-wide (914.4 mm-wide) structure, and 40.00 inches (1016.0 mm) for 40.00-inch-wide (1016.0-mm-wide) structure.
- ⑪ HV conduit space, load.
- ⑫ HV conduit space, line only.
- ⑬ HV conduit space, line only. Line cables to enter in rear half of conduit space only.
- ⑭ LV conduit space only.
- ⑮ Load terminations located on rear wall of starter mounted on a load panel. Terminations are arranged horizontally from left to right. T1, T2, T3 left to right at 4.38-inch (111.3 mm) centers.
- ⑯ Load terminations located on rear wall of reduced voltage enclosure mounted on a load panel. Terminations are arranged horizontally from left to right. T1, T2, T3 left to right at 4.38-inch (111.3 mm) centers.
- ⑰ HV conduit space, load cables for two-high starters. Cables for lower starter enter in rear half of conduit space, and cables for upper starter enter in front half.
- ⑱ Tolerances –0.0” +0.25” per structure.
- ⑲ Conduits to extend a maximum of 2.00 inches (50.8 mm) into structure.
- ⑳ Structure is 40.00 inches (1016.0 mm) wide for locked rotor currents greater than 1200A.

Eaton Corporation
Electrical Sector
1111 Superior Avenue
Cleveland, OH 44114 USA
Eaton.com

© 2012 Eaton Corporation
All Rights Reserved
Printed in USA
Publication No. TD02003002E / Z12401
August 2012



Eaton is a registered trademark
of Eaton Corporation.

All other trademarks are property
of their respective owners.