



Cutler-Hammer

Instructions for Ampgard® 720 Ampere Medium Voltage Starter

Instruction Booklet IB48043

Effective September 2008

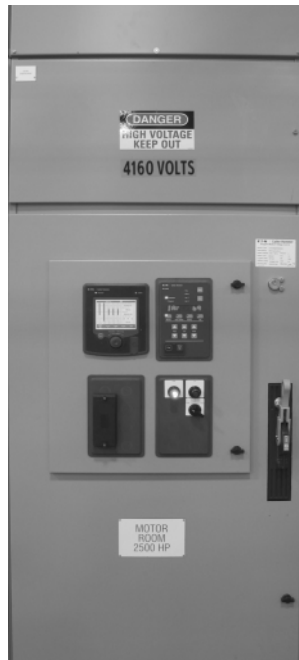

720-Ampere Starter with MP3000 and Power Xpert®

DANGER

READ AND UNDERSTAND THIS MANUAL IN ITS ENTIRETY BEFORE INSTALLING OR OPERATING CONTROLLER. INSTALLATION, ADJUSTMENT, REPAIR AND MAINTENANCE OF THESE CONTROLLERS MUST BE PERFORMED BY QUALIFIED PERSONNEL. A QUALIFIED PERSON IS ONE WHO IS FAMILIAR WITH THE CONSTRUCTION AND OPERATION OF THIS EQUIPMENT AND THE HAZARDS INVOLVED.

Introduction

This instruction book is intended to cover the handling, installation, operation and maintenance of Ampgard 720 ampere, 7.2 kV starters and associated equipment. The function of these controllers is to start, stop and protect medium voltage motors, transformers, capacitors and other loads. Controllers may be of full voltage, reduced voltage reactor, reduced voltage autotransformer or two-speed type. They may control induction or synchronous machines, and may be non-reversing or reversing.

While this instruction book is dedicated primarily to full-voltage starting, the other applications listed are an expansion of the principles identified in this book. This book does not purport to cover all possible contingencies, variations and details that may arise during operation or maintenance of this equipment. If further information is desired regarding this product, contact your local Eaton sales office.

Identification

A rating nameplate is located on the door of each controller. Contained on this nameplate are the controller type and ratings as required by industry standards. Also contained on this nameplate is the factory's general order number. This number should be given to the Eaton sales office if a question should arise concerning the equipment or if renewal parts are required. Refer to **Figure 1** for typical location of rating nameplates.

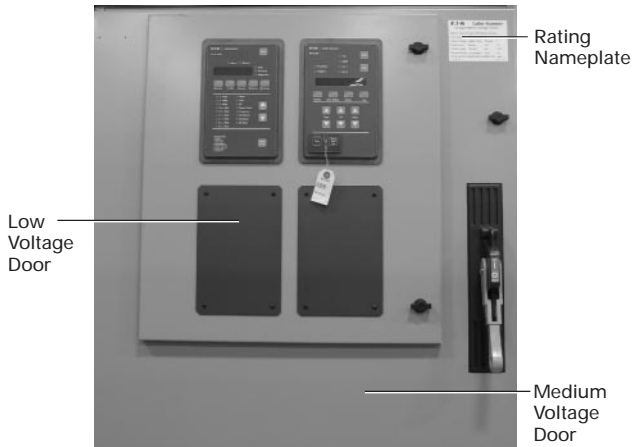

FIGURE 1. STARTER WITH RATING NAMEPLATE

⚠ DANGER

EXCEEDING THE NAMEPLATE RATINGS OF AN AMPGARD CONTROLLER MAY CAUSE EQUIPMENT DAMAGE, SEVERE INJURY OR DEATH.

Do not apply an Ampgard controller beyond its nameplate ratings.

Description

Controller

The Ampgard 720 ampere, 7.2 kV controller consists of a non-load-break isolation switch, medium voltage current limiting fuses, one or more Type SL vacuum-break contactors, a set of current transformers, plus control and protection devices. The isolating switch has a limited make and break rating, suitable only for closing and opening limited transformer magnetizing currents. The controller is designed to start, stop and protect a three-phase medium voltage motor within the ratings shown in **Table 1**. The controller may also be used to switch transformer windings or capacitor loads as shown. For applications other than those indicated, consult the factory. Each Ampgard controller occupies all or a portion of a steel structure that may also enclose a horizontal bus system to distribute power to two or more sections and a vertical bus system to connect individual starters to the horizontal bus. The controllers are configured for full-voltage or reduced voltage starting, reversing or non-reversing, in single-speed or two-speed applications.

Starters are supplied with bolt-in main fuses. Contactors have stab-in connections to the starter cell.

The flow of current through a starter with bolted fuses and a stab-in contactor can be described as follows: The line finger assembly mounted at the back of the enclosure serves to connect the isolation switch moving stabs to the controller line terminals when the switch is closed. Power flows from the switch moving stabs through two flexible shunts to the upper fuse mountings. The fuses are connected to the lower fuse mountings that contain the line-side stab connections to the line finger assemblies for the main contactor. With the main contactor energized, power flows through the contactor's vacuum interrupters to the contactor load fingers, which are engaged on to the controller load-side stabs. Medium voltage cables connect the load-side stabs to the motor load connections. The contactor is held in place by a set of rails mounted in the lower part of the cell. The motor load connections are mounted to the left of the main fuses in the rear of the compartment, facing forward. Current transformers are typically mounted just below the motor load connections.

TABLE 1. CONTROLLER RATINGS

DESCRIPTION	SJ 25V830	SJ 33V830	SJ 50V830	SJ 72V830
Utilization Voltage	2200 to 2500 Volts	3000 to 3300 Volts	3800 to 5000 Volts	6000 to 7200 Volts
Interrupting Rating: NEMA Unfused (E1) NEMA Fused (E2)	12.5 kA 200 MVA at 2300 Volts	12.5 kA 285 MVA at 3300 Volts	12.5 kA 408 MVA at 4600 Volts	12.5 kA 570 MVA at 6600 Volts
Interrupting Rating	50 kA	50 kA	50 kA	50 kA
Induction Motor	3000 hp	4000 hp	5000 hp	8000 hp
Synchronous Motor	(0.8 PF) 3000 hp (1.0 PF) 3500 hp	4000 hp 5000 hp	5000 hp 6000 hp	8000 hp 10,000 hp
Transformer	2500 kVA	3500 kVA	4500 kVA	6000 kVA
Capacitor 3-Phase	2400 kvar	3200 kvar	4000 kvar	4800 kvar
Maximum Insulation Voltage:	7200 Volts	7200 Volts	7200 Volts	7200 Volts
Maximum Interrupting Current (3 Operations) Rated Current	12,500 Amperes 720 Amperes Enclosed 800 Amperes Open	Arcing Time Pickup Voltage Dropout Voltage Control Voltages	12 Milliseconds (3/4 Cycle) or Less 80% Rated Coil Voltage 60% Rated Coil Voltage	
IEC Make-Break Capability-AC4 Class 3		(ac)/(dc)	110/120/220/240 Volts (50/60 hz)	
Make	8000 Amperes		125 Volts (dc)	
Break	6400 Amperes	Control Circuit Burden (Rated Volt)		
Short Time Current		Closing (ac)/(dc)	2600 VA	
30 Seconds	4320 Amperes	Holding (ac)/(dc)	80 VA	
1 Second	10,800 Amperes	Auxiliary Contact Rating (L-64)		
8.75 Milliseconds (.5 Cycle)	86 kA Peak	Voltage (Maximum) Continuous Current	600 Volts 10 Amperes	
Mechanical Life	1 Million Operations	Making Capacity (ac)	7200 VA	
Electrical Life	250,000 Operations At Rated Current	Making Capacity (dc)	200 VA	
		Breaking Capacity (ac)	720 VA	
BIL	60 kV (1.2 x 50 Microseconds)	Breaking Capacity (dc)	200 VA	
Dielectric Strength (60 Hz)	18.2 kV (1 Minute)	Latch (When Specified)		
Closing Time (Energization to Contact Touch)	80 Milliseconds	Mechanical Life Trip Voltages (dc) Trip Voltages (ac)	250,000 Operations 24 Volts/48 Volts/96 Volts 110 Volts/220 Volts (50/60 Hz)	
Opening Time	130 to 330 Milliseconds (130 is standard)	Tripping Voltage Tripping Burden	80% Rated Coil Voltage	
		24 Vdc 48 Vdc and 96 Vdc 110 Vac and 220 Vac Weight	200 VA 400 VA 500 VA 95 lbs. (43 kg)	

Low Voltage Components

The low voltage components consisting of a protective relay, interposing relay, test power circuit, terminal blocks and optional equipment are mounted in the low voltage control compartment located on the front of the controller medium voltage door. The low voltage compartment is fabricated from steel sheets to provide isolation from the medium voltage components mounted behind the low voltage compartment. A window is provided in the low voltage compartment to allow the user to view the position of the isolation switch before entering the medium voltage compartment. See section on Isolation Switch for further details.



FIGURE 2. MEDIUM VOLTAGE COMPARTMENT

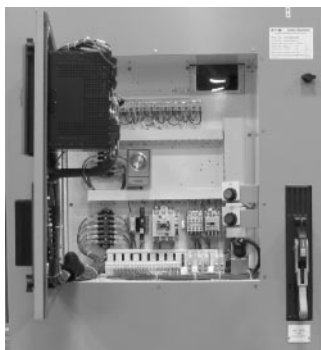

FIGURE 3. LOW VOLTAGE COMPARTMENT

Isolation Switch

The controller isolation switch is a non-loadbreak device. Mechanical and electrical interlocks are provided to ensure that the main contactor is de-energized before the switch can be operated. In the open position, the switch isolates medium voltage from the main controller compartment, allowing access to the controller for inspection and maintenance. For standard applications, the isolation switch includes ground fingers that ground the line side of the power fuses when the switch is in the open position.

⚠ DANGER

AMPGARD CONTROLLERS ARE SOMETIMES ENERGIZED BY A BACK-FED CONDITION THAT ALLOWS THE MEDIUM VOLTAGE COMPARTMENT TO BE ENERGIZED WITH THE ISOLATION SWITCH IN THE OPEN POSITION. STUDY THE PLANT SINGLE LINE DIAGRAMS TO MAKE CERTAIN THAT NO BACK-FEED SITUATION EXISTS BEFORE ENTERING THE MEDIUM VOLTAGE COMPARTMENT. ALL POWER SOURCES MUST BE ISOLATED AND LOCKED OUT BEFORE SERVICING THE EQUIPMENT. FOR APPLICATIONS WHERE THE CONTROLLER IS BACK FED, THE GROUNDING FINGERS SHOULD BE REMOVED FROM THE ISOLATION SWITCH.

The switch consists of a fixed rear portion and a removable front portion. Refer to **Figures 5 and 6**. The fixed portion includes the controller line fingers and a moveable shutter that isolates the line fingers when the switch is in the open position. The removable portion is operated by a handle mechanism that extends through the controller medium voltage door. With the handle in the up position, the switch is closed and medium voltage is available for connection to the controller load. With the handle in the down position, the switch is open and medium voltage is isolated from the controller and the controller load.

An isolation switch viewing window is provided in the upper rear corner of the low voltage control compartment. After opening the isolation switch and before opening the medium voltage door, the switch should be visually examined through the viewing window to verify that it is in the open position. Three green and white "barber poles" will be visible when the switch is in the open position and the shutter assembly is in the isolating position. See **Figure 4** for location of barber poles. The use of a flashlight will help in verifying the position of the "barber poles."



FIGURE 4. SHUTTER CLOSED

⚠ DANGER

DO NOT ENTER THE MEDIUM VOLTAGE STARTER COMPARTMENT WITHOUT VISUALLY VERIFYING THAT THE ISOLATION SWITCH IS OPEN AND THE ISOLATING SHUTTER IS IN PLACE. ENTERING A COMPARTMENT WITHOUT THE ISOLATING SHUTTER IN PLACE MAY RESULT IN SEVERE INJURY OR DEATH.



FIGURE 5. FIXED PORTION — ISO SWITCH

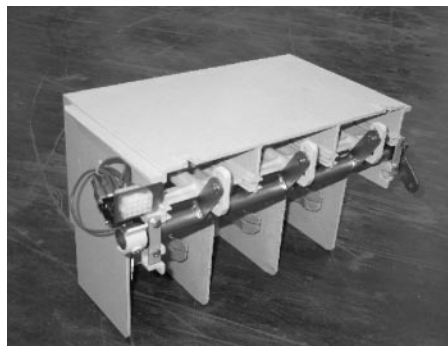

FIGURE 6. REMOVABLE PORTION — ISO

Power Fuses

Ampgard controllers are supplied with Cutler-Hammer® Type CLS current limiting power fuses. Fuses are of the bolt-in type. All fuses include an indicator that pops up when the fuse has blown. An optional blown fuse trip bar may be supplied. The mechanism is mounted on the controller isolation switch and is typically wired to trip the controller off-line in the event of a blown fuse.

Vacuum Contactor

720 ampere Ampgard Medium Voltage Controllers are supplied with 800-ampere vacuum contactors. The contactor has an interrupting rating of 12,500 amperes and is open-rated to carry 800 amperes continuously. The contactor enclosed rating is 720 amperes.



FIGURE 7. 800 AMPERE SL VACUUM CONTACTOR

Contactors are typically 3-pole devices except in the case of the start contactor on autotransformer starters, which are normally 2-pole devices.

Refer to Instruction Book IL17047B for further details on the operation and maintenance of the vacuum contactors.

Controllers supplied as transformer feeders or for other specialized applications are sometimes supplied with contactors that include a mechanical latch device. Refer to Eaton for further details on the operation and maintenance of the latch mechanism.

Safety Interlocks

Ampgard controllers are manufactured with several built-in interlock provisions and safety features to reduce hazards and provide proper operating sequences.

A mechanical interlock prevents opening the medium voltage door with the switch in the closed position. Ensure that the medium voltage door is fully closed and latched using the two latches on the right side of the door to prevent damage to the interlock bracket on the back of the door.

An additional interlock prevents closing of the switch unless the medium voltage door is closed (see MV Door Interlock Plunger in **Figure 8**). On controllers that require two structures (reduced voltage starters for example), the door to the second structure will also be interlocked with the switch operating mechanism. The second door must be closed before the main door is closed. Both doors must be closed before the switch operator can be moved to the closed position.

Note: Attempting to close the switch with the door open can cause damage to the operating mechanism.

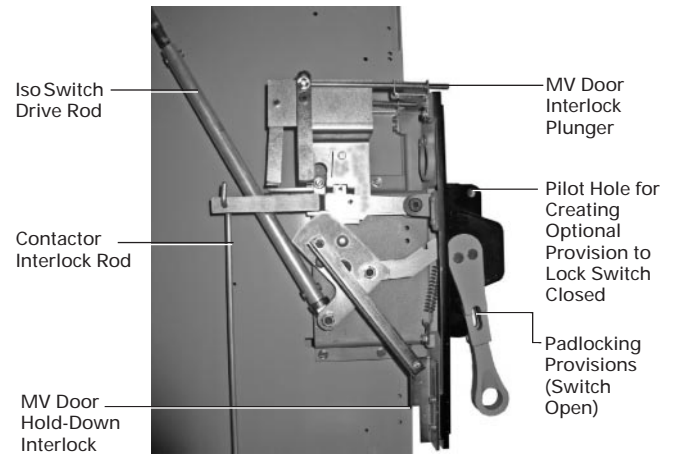

FIGURE 8. HANDLE MECHANISM WITH CONTACTOR AND DOOR INTERLOCKS

Mechanical and electrical interlocks are provided to ensure that the non-loadbreak isolation switch cannot be opened or closed unless the main contactor is de-energized (see contactor interlock rod in **Figure 8**). Do not attempt to force the switch operating mechanism with the main contactor closed. The handle mechanism is designed to fail before the isolation switch can be opened with the main contactor closed.

CAUTION

APPLYING EXCESSIVE FORCE TO THE SWITCH HANDLE WITH THE MECHANICAL INTERLOCKS ENGAGED WILL RESULT IN DAMAGE TO THE SWITCH.

An electrical interlock is provided to disconnect the control power transformer secondary before the isolating switch stabs are disconnected from the controller line fingers. This interlock ensures that the switch is breaking transformer magnetizing current only. Do not connect additional loads to the controller isolating switch.

DANGER

IF LOADS GREATER THAN THE INTERRUPTING RATING OF THE SWITCH ARE CONNECTED TO THE SWITCH, EQUIPMENT DAMAGE, PERSONAL INJURY OR DEATH MAY OCCUR.

An optional key interlock may be provided to lock the switch in the open position for special configurations. Refer to the specific order drawings to determine if key interlocks have been provided.

On reversing, two-speed or autotransformer type starters, mechanical interlocks are provided to prevent two or more contactors from closing at the same time.

Low Voltage Control

The low voltage control compartment is located in a steel pocket in the medium voltage door. A low voltage door with up to four device panels provides access to the low voltage compartment with the medium voltage door closed. The low voltage compartment swings out of the way with the medium voltage door as it is opened, allowing access to the isolation switch, fuses, main contactor, and other starter components that are mounted behind the low voltage compartment.

A row of control terminal blocks is provided on the left side of the controller. They can be accessed by opening the low voltage door. The blocks are fixed mounted and remain in place when the medium voltage door is opened. Refer to **Figures 9** and **10** for details.

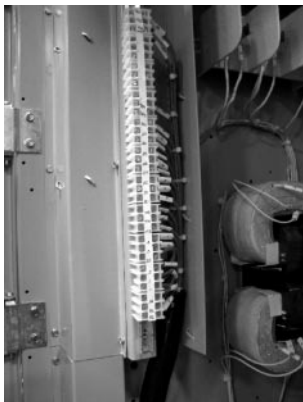

FIGURE 9. LV TERMINAL BLOCKS, MV DOOR OPEN



FIGURE 10. LV TERMINAL BLOCKS, LV DOOR OPEN

A test plug and receptacle are typically supplied inside the low voltage section. The receptacle is wired to the secondary of the controller control power transformer. Test power can be used to energize the control circuit by removing the plug from the receptacle and using a standard extension cord to energize the plug. Refer to **Figure 11** for specific location.



FIGURE 11. LV COMPARTMENT WITH TEST PLUG

DANGER

DO NOT CONNECT TEST POWER TO THE STARTER CONTROL CIRCUIT WITHOUT REMOVING THE PLUG FROM THE RECEPTACLE. FAILURE TO DO SO WILL RESULT IN A BACK-FEED CONDITION ON THE CONTROL POWER TRANSFORMER, WHICH WILL GENERATE HIGH VOLTAGE INSIDE THE CONTROLLER WITH THE ISOLATION DEVICE OPEN. HIGH VOLTAGE CAN CAUSE SEVERE INJURY OR DEATH.

Current Transformers

A 3-phase CT is provided as standard on all starters. The standard mounting location for the CT is under the motor load connection assembly. The three CTs in the assembly are provided with the proper ratio and output burden to work properly with the overload relay supplied in the control compartment.

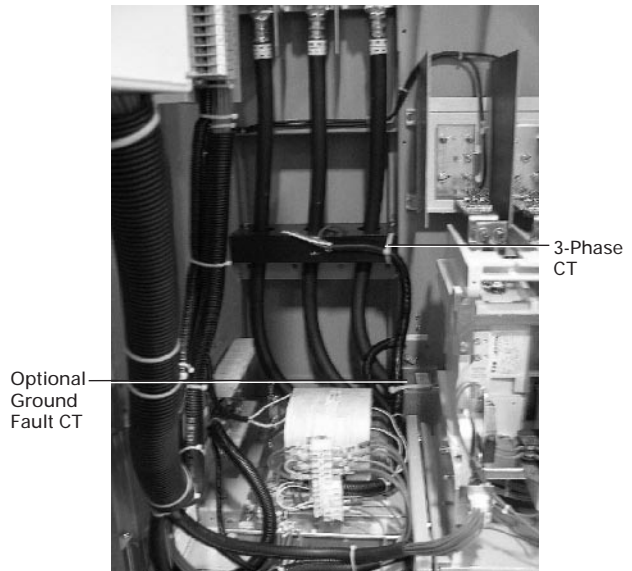

FIGURE 12. STANDARD CT MOUNTING

Main Bus

Ampgard lineups are typically supplied with copper main bus. The bus is located in a 12-inch high bus compartment mounted at the top of the lineup. Bus may be rated 1000, 1200, 2000 or 3000 amperes. The standard bus is un-insulated and tin-plated. Optional insulation and silver plating are available. Bus specifications can be found on the job specific order drawings.

The main bus compartment in a starter section includes vertical bus drops to connect the starter(s) to the main bus. Also included are wireways for routing of motor load and control cables to the starters below.



FIGURE 13. MAIN BUS COMPARTMENT, TOP VIEW

Installation

Handling

An Ampgard controller is insulated for high voltages and must be protected against damage during handling. The controller should remain in an upright position at all times.

Exercise extreme care during any movement and placement operations to prevent dropping or unintentional rolling or tipping. Ampgard medium voltage equipment may be moved by forklift, rollers or overhead crane.

A forklift is usually the most convenient method of handling the controller. Use safety straps around the protective packaging material when handling the controller with a forklift. Insert the forks under the shipping skid. Do not allow the end of the forks to enter the bottom of the enclosure.

Rod or pipe rollers provide a simple method for moving the controller on a level floor. The bottom of the Ampgard structure is designed to be rolled without damage on minimum 2-inch diameter rollers, four rollers per 36-inch section.

Ampgard controllers are shipped with two steel lifting angles, one in front and one in back, running the full width of the shipping section. Back-to-back units also have one in the back and one in the front, running the full width of the shipping section. Select or adjust the rigging lengths to compensate for any unequal distribution of the load, and maintain the controller in an upright position. Some controller interiors may contain heavy equipment, such as transformers, that can make the center of gravity vary considerable from the center of the lineup. **Do not allow the angle between the lifting cables and vertical to exceed 45 degrees.** Do not pass ropes or cables through the lift holes. Use slings with safety hooks or shackles, of adequate load rating.

⚠ CAUTION

EACH CONTROLLER IS PROPERLY ADJUSTED AT THE FACTORY BEFORE SHIPMENT. HOWEVER, VIBRATION AND MECHANICAL STRESSES IMPOSED BY TRANSIT AND INSTALLATION CAN ADVERSELY AFFECT MECHANICAL INTERLOCKS AND OTHER ADJUSTMENTS; THEREFORE, A FINAL INSPECTION IS ESSENTIAL BEFORE ENERGIZING. IF THIS INSPECTION REVEALS ANY PORTION OF THE CONTROLLER HAS COME OUT OF ADJUSTMENT, THE CONTROLLER SHOULD BE RE-ADJUSTED ACCORDING TO INFORMATION IN THIS INSTRUCTION BOOK OR BY A QUALIFIED EATON SERVICE ENGINEER.

Storage

If it is necessary to store an Ampgard controller before installation, keep it in a clean, dry location with ample air circulation and heat to prevent condensation. Like all electrical apparatus, an Ampgard controller contains insulation that must be protected against dirt and moisture.

Mounting

Ampgard controllers should be installed on a non-combustible level surface of sufficient strength to properly support the controller's mass. After the lineup has been placed in position, anchor bolts may be installed and tightened. Refer to the job specific order drawings for the bolt locations. The use of 1/2 inch diameter bolts is recommended.

Equipment located in certain seismic zones must be anchored to meet the requirements of those zones. Refer to Eaton I.B. 48042 for instructions on mounting in these special locations. It is the user's responsibility to ensure the mounting pad is sufficiently strong to properly anchor and support the equipment.

When an order includes two or more shipping sections, the order outline drawing will show the sequence in which the sections are to be lined up and which shipping splits are to be joined. A bus bar splice kit and a connecting hardware kit are supplied for each open joint between sections.

Place the first shipping split into position. Move the second shipping split into position alongside the first and use the six or eight 3/8 x 1.50 inch bolts and companion hardware to connect the two sideplates.

Place one flat washer under the bolt head and one flat washer and one lock washer under the nut. Tighten each bolt to 25 lb-ft (33 N-m).

Bus Splicing

Connect the bus bars using the splice kit, including hardware (3/8-inch diameter) that is provided with the equipment. Tighten bolts to 25 lb-ft (33 N-m).

Power Connections

Incoming power connects to the lineup in a variety of ways. Cables, bus from other close-coupled equipment, bus duct and transformer shunts are some of the more common methods. Note that these connections may be energized even when the starter isolation switch or other switching devices are in the open position.

⚠ DANGER

DE-ENERGIZE AND LOCKOUT ALL INCOMING POWER CONNECTIONS AT THEIR SOURCE BEFORE SERVICING ANY PART OF THE EQUIPMENT DIRECTLY CONNECTED TO THE INCOMING POWER, INCLUDING MAIN HORIZONTAL BUS, VERTICAL BUS, BUS POTENTIAL TRANSFORMERS OR CONTROL POWER TRANSFORMERS.

Review the order drawings supplied with the equipment for information on the incoming connections for your specific equipment.

Ensure that all connections are tight and of the proper ampacity to carry the rated load. Cables should be properly supported and braced, with special attention to ensure that the insulation is protected from damage.

Motor Load Cable Termination

Motor load cable terminations are typically located in the left rear of the controller compartment. Refer to **Figure 14** for location details. In reduced voltage starters, the terminations are located in the reduced voltage compartment. Load cables may exit either the top or bottom of the structure. Ensure that the factory supplied phase barriers are installed before energizing the starters. Failure to do so can result in a flashover at the load connections.



FIGURE 14. MOTOR LOAD CONNECTIONS, SHOWN WITH OPTIONALLY SUPPLIED LUGS



FIGURE 15. TOP COVER (VIEW FROM FRONT OF BUS COMPARTMENT, BACK-TO-BACK STRUCTURES)

Control Connections

Control wires may enter the enclosure from either the top or the bottom. For lineups with main bus, a low voltage wireway is located in the left front of the bus compartment to facilitate top entry of control wiring. For controllers where bottom entry is used, wires enter the lower left front of the enclosure. Refer to the order specific drawings for locations for control wireways.

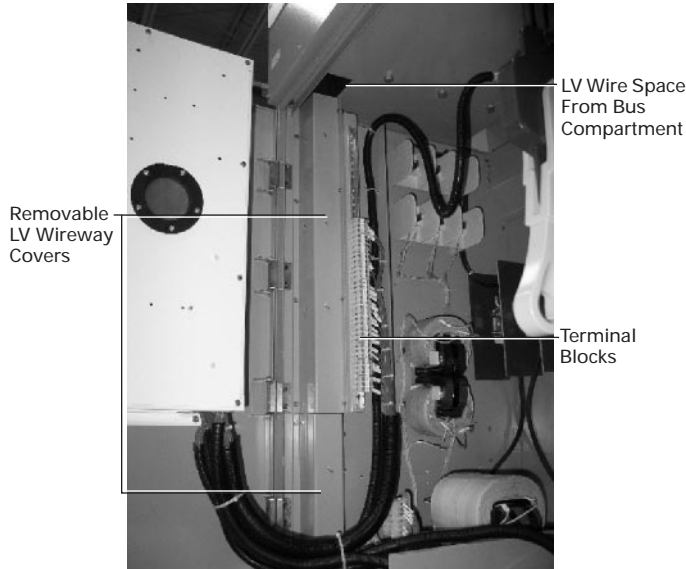

FIGURE 16. LOW VOLTAGE TERMINAL BLOCKS AND VERTICAL WIREWAY

A fixed row of terminal blocks for control connections is located in the left front of the controller compartment. The starter isolation switch should be in the disconnected position and the medium voltage door open for wiring access to these terminal blocks.

When top entry of LV wiring is used, make sure that the wiring is routed to the left and secured using wire ties as soon as possible to prevent interference with the low voltage control compartment when the medium voltage door is closed.

Some wiring may need to be connected to devices on the low voltage door or in the low voltage compartment. Wiring to these devices should come through one of the wire cutouts in the bottom left of the low voltage compartment. Make sure that there is sufficient slack in the wiring to allow the medium voltage door to open properly.

A horizontal low voltage wireway is located at the bottom front of each lineup. The equipment ground bus is also located in the wireway. This area may be used to route control wires that must pass from one structure to another.

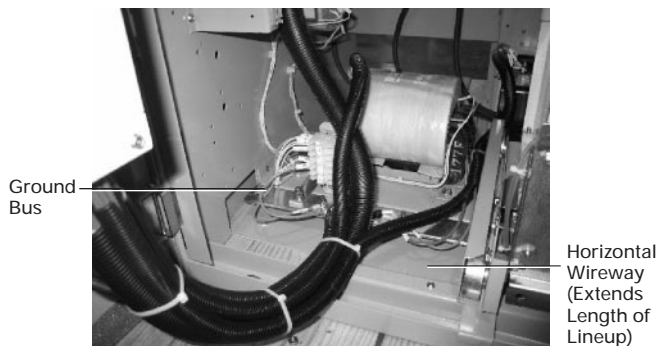

FIGURE 17. HORIZONTAL WIREWAY AND GROUND BUS

Setting of Adjustable Protective Devices

Ampgard controllers may contain protective devices such as solid-state motor protection relays, overcurrent relays, incomplete sequence timers, and other devices critical to the proper operation of the starter. Due to the wide variation in job site parameters, these devices are not set at the factory. It is the purchaser's responsibility to ensure that all adjustable devices are properly set before energizing the equipment. All warranty is void if adjustable devices are not properly set prior to initially starting the equipment.

DANGER

FAILURE TO PROPERLY SET ADJUSTABLE DEVICES MAY RESULT IN EQUIPMENT DAMAGE, PERSONAL INJURY OR DEATH.

Pre-startup Checks

Before attempting to put a newly installed controller into service, study the wiring diagrams, control schematics, other order specific drawings, and all instruction literature. Ensure that all adjustable devices, including protective relays and timers, have been properly set.

Verify that the controller and motor are connected per the Eaton drawings. This is particularly essential in this class of equipment as the fuse ratings, current transformers, and overload protection are based on the characteristics of the particular motor (or other load) to be controlled.

Ensure that all safety precautions have been taken and that the installation conforms to applicable regulations and safety practices.

The equipment should be cleaned of dirt, scraps of wire, tools and other foreign material.

The dielectric strength of the vacuum interrupters should be checked before the contactor is energized for the first time and regularly thereafter to detect at the earliest possible date any deterioration in the dielectric strength of the interrupter, since this may result in an interruption failure. The test is best performed with the contactor removed from the controller cubicle. Removal instructions can be found later in this IB in the Maintenance/Contactor section. If testing is performed with the contactor installed, care must be taken to ensure no damage is inflicted on the controller control power transformer, potential transformers or to the controller load. Removal of the primary fuses is sufficient to protect the CPT or PTs. Cables to the load should be disconnected. Although an AC test is recommended, a DC test may be performed if only a DC test unit is available. A good vacuum interrupter will withstand a 16 kV – 60 Hz test or a 23 kV –DC test across the normally open contact gap. When performing DC tests, the voltage should be raised in discrete steps until the final test voltage is reached. When tested with an AC high potential tester, expect a capacitance leakage current of approximately 1 milli-ampere per interrupter. Refer to IL17047B for more information on dielectric testing of the vacuum interrupters.

The insulation level of the starter should be checked and recorded before the unit is energized.

Enclosure doors should close easily. Do not force doors closed, but rather look for improperly positioned contactors, isolating switches or other devices.

Ensure that all phase barriers are in good condition and are properly installed. Refer to **Figures 14** and **18** for examples.

DANGER

FAILURE TO INSTALL PHASE BARRIERS CAN RESULT IN EQUIPMENT DAMAGE, SEVERE INJURY OR DEATH.



FIGURE 18. LOWER FUSE MOUNTING WITH PHASE BARRIERS INSTALLED

Verify that the contactor is fully inserted into the controller compartment. All finger-stab combinations must be properly engaged. A mounting bracket is provided to secure the contactor in the cell. Verify that the securing bolt is in place and properly tightened to the bracket. A small gap between the contactor baseplate and the mounting bracket is normal.

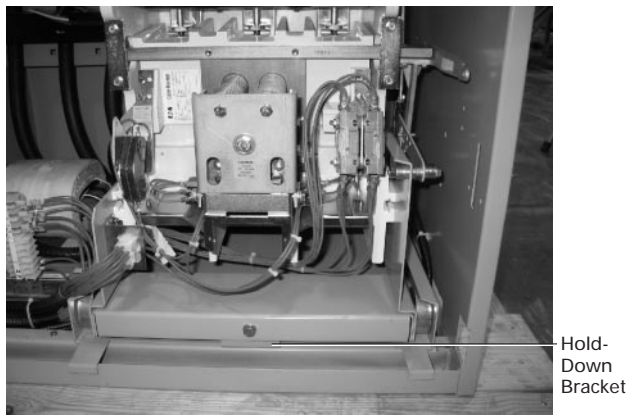

FIGURE 19. CONTACTOR HOLD-DOWN BRACKET

⚠ DANGER

ALL SOURCES OF MEDIUM VOLTAGE MUST BE ISOLATED AND LOCKED OUT AT THE UPSTREAM FEEDER BEFORE THE INTERLOCK CHECK CAN BE PERFORMED. FAILURE TO ISOLATE AND LOCKOUT ALL INCOMING POWER TO THE LINEUP CAN RESULT IN EQUIPMENT DAMAGE, SEVERE INJURY OR DEATH.

Mechanical interlocks should be checked as follows: Isolate and lock out all incoming power sources. Open the isolation switch. Open the medium voltage door. Verify that the mechanical interlocks between the contactor and handle mechanism are connected and functioning properly. The switch drive rod connection and the contactor interlock rod connections should be verified by operating the handle mechanism, open-to-close-to-open. The door interlock plunger must be held in by hand during this operation. Verify that the pivot arm on the handle mechanism drops down and makes contact with the cam after the handle is fully closed. Failure to contact the cam may indicate a problem with the adjustment of the aluminum interlock arm on the contactor. Close the main contactor with test power and attempt to operate the switch while holding the door interlock plunger in. The mechanical interlock should prevent the switch from operating. Avoid putting excessive force on the operating handle during this operation or damage to the handle mechanism may occur. **Make sure that the door interlock plunger returns to its normal forward position after releasing. If the plunger remains in the depressed position after it is manually released, the interlock will not properly function to prevent operation of the switch with the door open.**

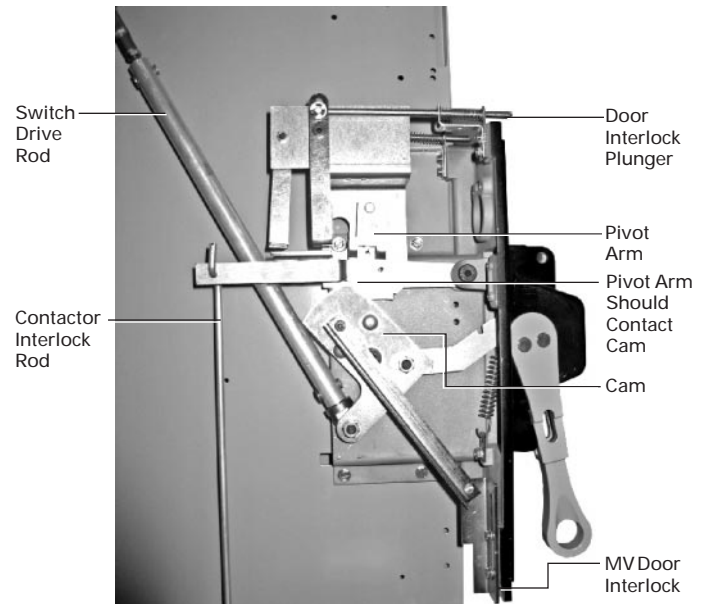

FIGURE 20. MECHANICAL INTERLOCK VERIFICATION

Maintenance

A maintenance program should be established as soon as the controller has been installed and put into operation. After the controller has been inspected a number of times at monthly intervals and the conditions noted, the frequency of inspection can be increased or decreased to suit the conditions found.

Before attempting maintenance, consult the order specific drawings and instructions supplied with the controller.

Insulation Level

The insulation resistance between poles, and from each pole to ground, should be measured and recorded. It is not practical to specify an absolute value for this reading since it is dependent on other connected apparatus and conditions of service. However, any unusually low reading or abrupt reduction in a reading may indicate a possible source of trouble, and the cause should be investigated and corrected.

Fuses

Inspect the current limiting fuses after each relay initiated trip, since this is the most severe service to which they will be subjected. Check the fuse resistance, and compare with the value of a new fuse. A visual sign of an open fuse is provided by a pop-up indicator on the top of the fuse. If a fuse has blown due to a fault, it is likely that the other fuses experienced a similar overcurrent condition. In this case, Eaton recommends that all three fuses be replaced. Ensure that the replacement fuses are of the same rating and mounting configuration as those originally supplied.

Fuses can be removed by loosening the four nuts that secure the fuses to their mounting studs. The phase barriers on the lower fuse mountings can be removed if desired to ease access to the mounting studs and nuts. The upper phase barriers are not removable. If the optional blown fuse trip bar has been supplied, lift the operating arms up to clear the fuse mounting flanges. The arms will latch in the up position. Installation is the reverse of removal. Bolt-in fuses must be torqued to 25 lb-ft (33 N-m). Be sure to lower the blown fuse trip bar operating arms after all three fuses are reinstalled.

Contactors

Inspect the contactor line and load fingers for signs of arcing or overheating. Replace as necessary. Inspect the mechanical interlock components attached to right side of the contactor main operating shaft and side sheets. Ensure the lever is secure on the shaft and that the pivoting arm moves freely. Verify that the finger assemblies are in their neutral (horizontal) position before reinserting the contactor into the cell. No lubrication is required.

Refer to IL17047B for details of additional contactor operation and maintenance information.

Follow the steps below to remove the contactor from the starter cell. Installation is the reverse of the removal process. Note that the mechanical interlock mechanism on the side of the contactor must be reconnected before the contactor can be closed. The mechanism is weighted in such a manner that the contactor cannot operate until the interlock rod clevis is reconnected. **Figures 21** through **24** illustrate the removal sequence.

1. Unplug control harness.
2. Remove bolt from hold-down bracket.
3. Unsnap pin collar from interlock rod clevis.
4. Remove pin from interlock rod clevis.
5. Withdraw contactor from cell.

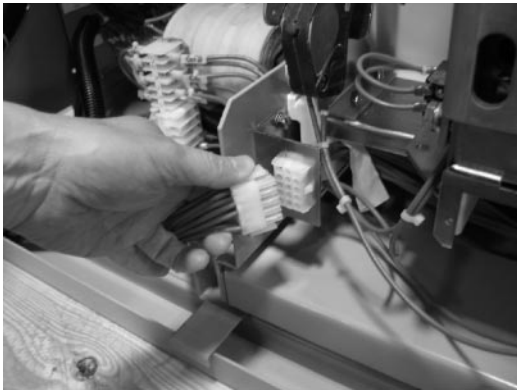

FIGURE 21. UNPLUG CONTROL HARNESS

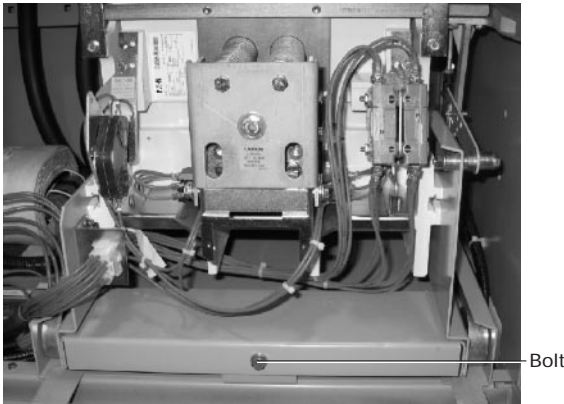

FIGURE 22. REMOVE BOLT-DOWN HARDWARE

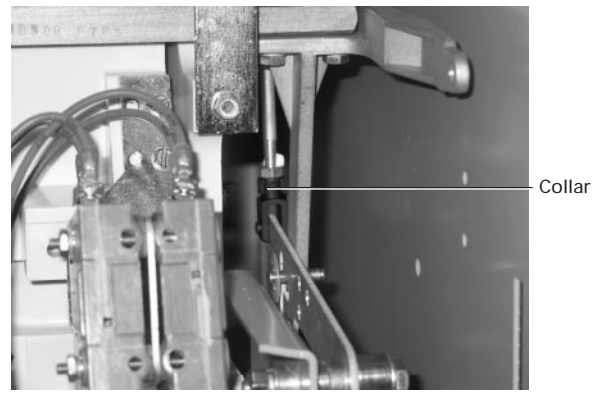

FIGURE 23. UNSNAP COLLAR



FIGURE 24. REMOVE COLLAR/PIN (PHOTO FROM 400 AMPERE STARTER FOR CLARITY)

Isolation Switch

The isolation switch consists of a fixed rear portion and a removable front portion. The switch should operate smoothly in both directions, with an increase in resistance as the stabs engage the controller line fingers. Inspect for any signs of mechanical wear or overheating.

To withdraw the removable portion:

1. Remove the three main fuses.
2. Remove the control plug.
3. Remove the cotter pin and clevis pin from the drive rod clevis.
4. Remove the two bolts securing the removable portion of the switch to the fixed portion.
5. Pull the switch forward, then down and out of the controller.

CAUTION

TAKE CARE NOT TO LET THE SWITCH QUICKLY DROP DOWN AS THE REMOVABLE PORTION SEPARATES FROM THE FIXED PORTION OR DAMAGE TO THE SHUTTER CAN OCCUR.

Note: The isolation switch phase barriers can only be removed after the removable portion of the switch has been withdrawn. Ensure that the barriers are in place before the switch is re-installed.

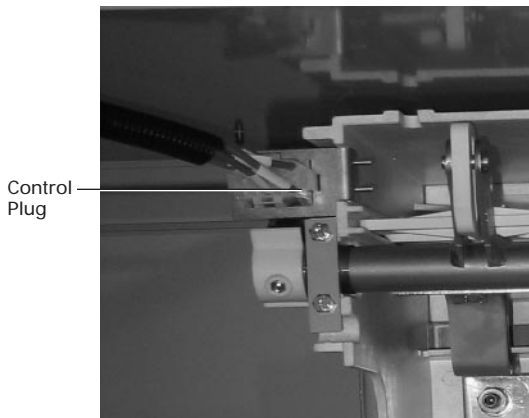

FIGURE 25. ISOLATION SWITCH CONTROL PLUG



FIGURE 26. ISOLATION SWITCH DRIVE ROD



FIGURE 27. BOLTS SECURING ISOLATION SWITCH

The fixed portion of the switch, including the isolating shutter, remains in the controller. Medium voltage may be present at the line fingers behind this shutter. Before attempting to inspect the line fingers or do other work on the fixed portion of the switch, ensure that the controller incoming power is isolated and locked out at an upstream feeder.

With the incoming power locked out, the fingers can be inspected and the vertical bus connections checked for tightness. Remove the polyester barrier mounted immediately below the switch for access to the vertical bus connections (refer to **Figure 27**). Verify the operation of the shutter mechanism by gently pushing it to the left. It should spring back to the closed position when released.

⚠ DANGER

FAILURE TO LOCK OUT INCOMING POWER BEFORE SERVICING THE FIXED PORTION OF THE SWITCH OR VERTICAL BUS CAN RESULT IN EQUIPMENT DAMAGE, SEVERE INJURY OR DEATH.

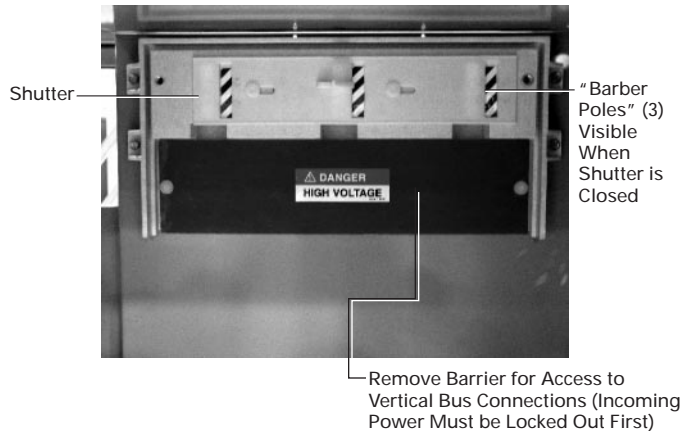

FIGURE 28. FIXED ISOLATION SWITCH

Reinstallation is the reverse of the procedure above. The switch phase barriers must be in place before reinstallation. Make sure that the shaft of the removable portion of the switch is rotated to the fully open position before reinstallation.

⚠ DANGER

IF THE SWITCH IS INSERTED WITH THE SHAFT IN THE CLOSED POSITION, THE SHUTTER MAY BE FORCED OPEN AND LIVE PARTS MAY BE CONTACTED, RESULTING IN SEVERE INJURY OR DEATH.

Door Interlock

A mechanical interlock prevents opening the medium voltage door with the switch in the closed position. A steel plunger lowers into position as the switch is closed. This plunger engages a bracket welded to the back of door, preventing the door from opening with the switch closed. In the unlikely event the switch malfunctions and cannot be opened, it will be necessary to drill out the welds to allow access to the medium voltage compartment. Refer to **Figure 29**. Use a 1/4-inch bit and drill out the two welds that can be seen just below the handle mechanism. After repairs are made to the switch mechanism, the door should be replaced with a new factory built part to ensure the restoration of the interlock feature.



FIGURE 29. DRILL LOCATION FOR EMERGENCY ENTRANCE TO MV COMPARTMENT

Eaton Corporation
Electrical Group
1000 Cherrington Parkway
Moon Township, PA 15108
United States
877-ETN-CARE (877-386-2273)
Eaton.com

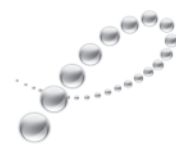

**PowerChain
Management®**

PowerChain Management, Ampgard, Cutler-Hammer and Power Xpert are registered trademarks of Eaton Corporation.

EAT•N

Cutler-Hammer

© 2008 Eaton Corporation
All Rights Reserved
Printed in USA
Publication No. IB48043 / Z7503
September 2008