

# Synchronizing power density, safety and reliability



With synchronous transfer capability, Eaton's SC9000 EP adjustable frequency drive is a state-of-the-art medium voltage drive that delivers features required by today's most demanding applications.

Synchronous transfer systems help our customers maximize capital efficiency of their systems by controlling multiple motors with one adjustable frequency drive. In multi-motor or soft-start applications, a synchronous transfer system is designed to ramp up multiple motors in series, transfer the load to adjacent bypass contactors and operate the motors at full speed. The system can ramp the motors down in series the same way. With the SC9000 EP and Eaton's integrated control gear double bus design, the

drive output and motor select contactors are closed-coupled under a common power bus, giving our customers a compact design and reduced cabling. Expanding beyond the industry's standard offering, Eaton's synchronous transfer technologies provide high performance in a compact footprint while lowering the total cost of ownership and enhancing safety. Eaton manufactures both the contactor sections and the drive and tests them as a system, at one facility, minimizing your system integration risks.



Example of back-to-back line up of synchronous transfer for oil platform application. Drives and starters are manufactured and tested at the same Eaton facility.

# SC9000 EP

For all your industrial applications

## Arc-resistant synchronous transfer

Going beyond the industry's first fully integrated arc-resistant medium voltage drives and leveraging Eaton's integrated double-bus synchronous transfer technology, Eaton is offering the industry's first synchronous transfer system in arc-resistant variation with double bus.

Each of the compartments were witness tested to IEEE C37.20.7 at a third party laboratory. This system provides users with unmatched safety features while providing cost effective and elegant installations.

## Closed-transition synchronous transfer

The key performance in a synchronous transfer system is the ability of synchronizing the drive's output to the utility's line power and providing a seamless transition.

With some transitioning methods, the motors are free coasting momentarily before it is pick-up by the drive or a contactor.

This method can provide bumpy transitions and puts unnecessary stresses to the mechanical system. The new closed-transition technology in Eaton's

SC9000 EP provides smooth transitions during both up-sync and down-sync transitions.

During the process of transfer to a contactor, the drive matches 60hz line power and closes contactors before powering down the drive. The process is reversed during re-transfer. The drive is designed to prevent the motors from free-coast, not even for milliseconds.

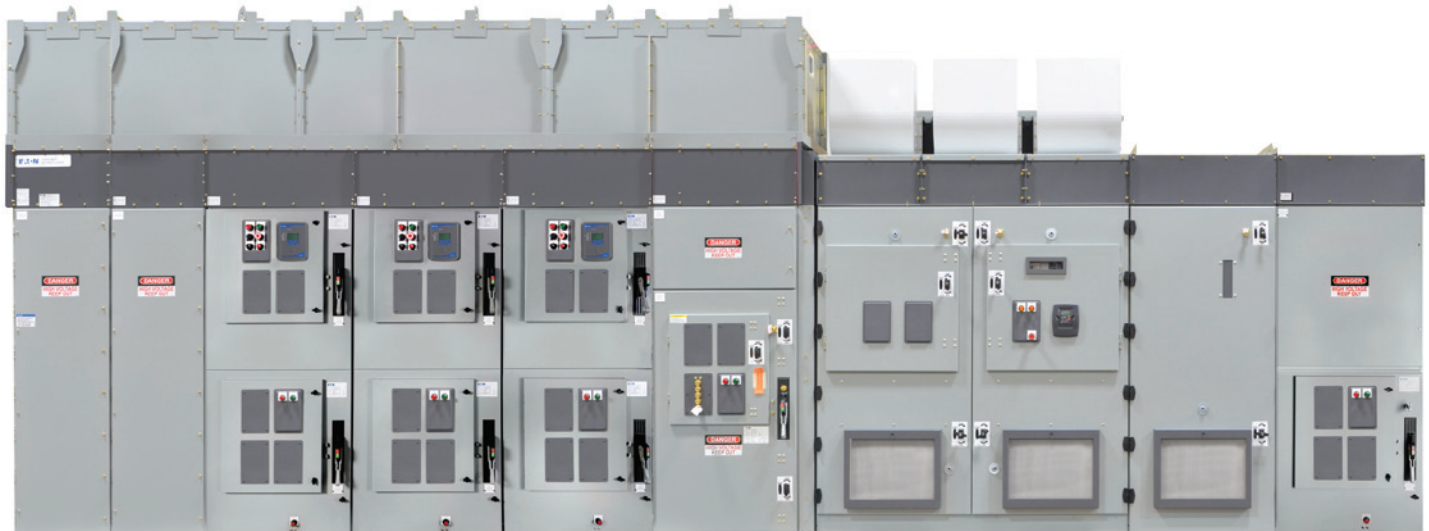

## SC9000 EP arc-resistant synchronous transfer system

Example of 3500 HP arc-resistant system with input sections and 3 motor starters

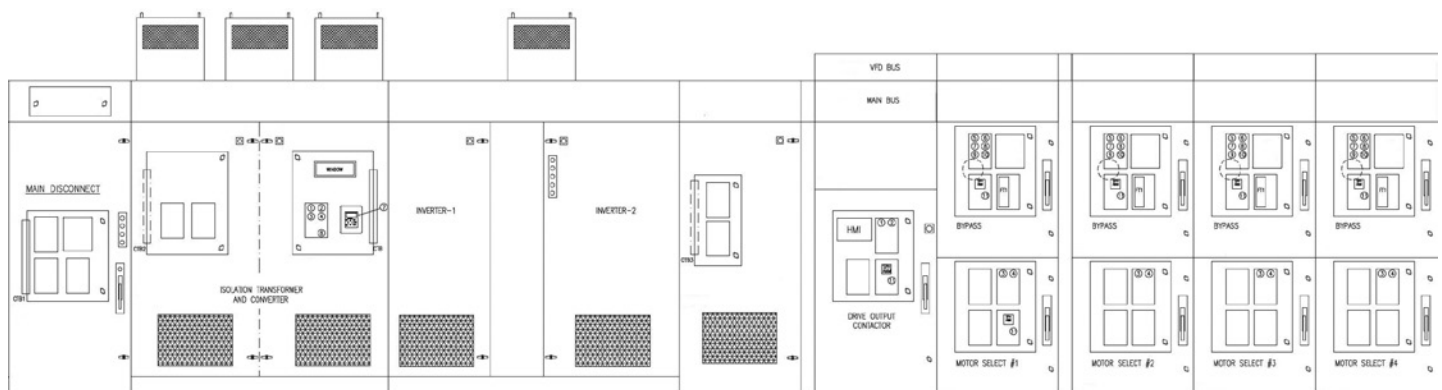

## SC9000 EP synchronous transfer system with closed-transition technology and double-bus

Example of 4500 HP system with 4 motors starters and main disconnect

# Closed transition transfer control operation

Operation of Eaton's Closed Transition Transfer Control System is described and illustrated below.

## Control elements key and definitions

- De-energized
- Energized feeder Bus
- Energized AFD Bus
- Closed contactor

PLC – transfer programmable logic controller

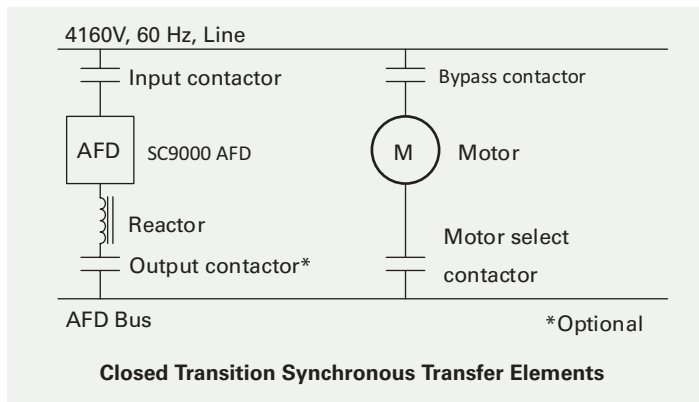

## Sequence of operation

1. Start sequence
  - a. Customer sends start signal to PLC
  - b. PLC closes appropriate motor select contactor and sends run command
  - c. AFD closes output contactor and pre-charger
  - d. Once pre-charge is complete, AFD closes input contactor (figure 1) and ramps to reference frequency

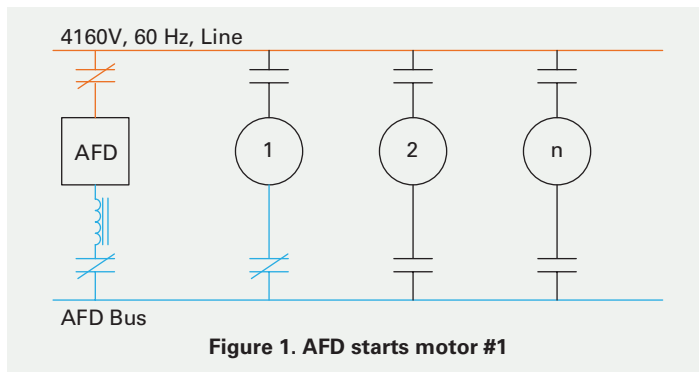

2. Sync up sequence
  - a. Customer sends sync up signal to PLC
  - b. PLC sends sync up command to AFD and locks output to match line voltage

- c. PLC closes bypass contactor and opens motor select (figure 2.1)

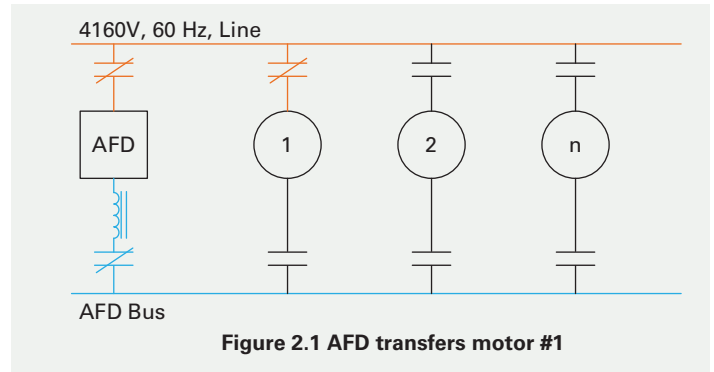

- d. AFD stops modulation, opens drive output contactor (figure 2.2), and sync up command is removed from AFD

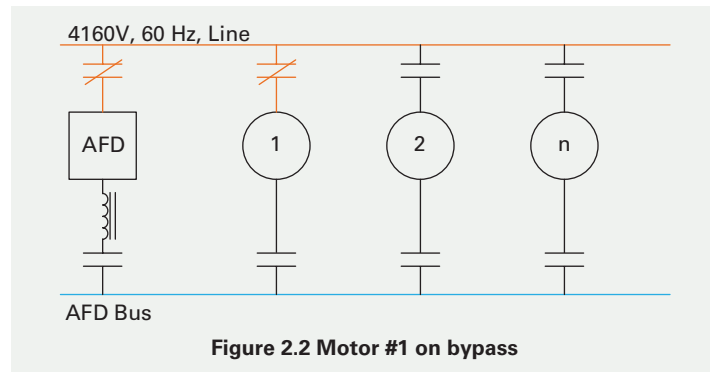

3. Sync down sequence
  - a. Customer sends signal to PLC to sync down motor
  - b. AFD pre-charges and closes main input contactor: AFD locks to line voltage
  - c. AFD closes drive output contactor and sends sync acknowledgment to the PLC (figure 3.1)

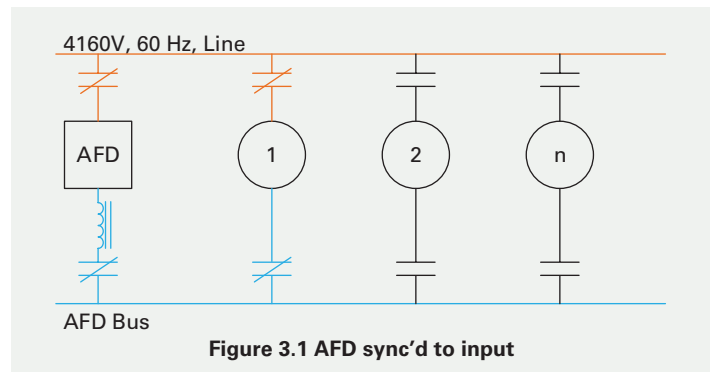

- d. PLC closes motor select and opens bypass contactor
- e. PLC sends command to AFD to turn on inverter
- f. AFD ramps motor to reference frequency

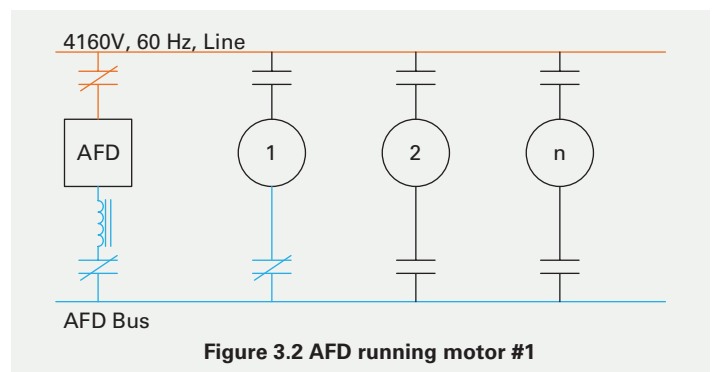

# Big value in a small package

## Stacked 800A contactor synchronous transfer

Eaton has packaged reliable performance into a more compact footprint offering increased value for your operation. Expanding from our 400A stacked contactors, Eaton now offers stacked contactors up to 800 amperes.

With the 800A stacked-contactor enclosure, the footprint is the same as the 400A stacked-contactor enclosure, which effectively reduces the footprint of contactor sections by 50% compared to a single 800A contactor enclosure. This design is also available as closed-transition.



**SC9000 EP stacked 800A contactor**  
Closed-transition with stacked 800A contactors

For more information, contact your  
local Eaton sales representative

[Eaton.com/SC9000](http://Eaton.com/SC9000)

1-877-ETN-CARE, option 2, then option 7

**Eaton**  
1000 Eaton Boulevard  
Cleveland, OH 44122  
United States  
[Eaton.com](http://Eaton.com)

© 2015 Eaton  
All Rights Reserved  
Printed in USA  
Publication No. PA020004EN / VCG1550  
November 2015

**EATON**  
Powering Business Worldwide

Eaton is a registered trademark.

All other trademarks are property  
of their respective owners.

Follow us on social media to get the  
latest product and support information.

