

# VariSTAR™ Type AZU heavy-duty distribution-class under-oil MOV surge arrester



## General

Eaton's Cooper Power™ series VariSTAR™ Type AZU under-oil MOV arrester is designed in accordance with IEEE Std C62.11™-1987 standard heavy-duty distribution class requirements. It is designed for either horizontal or vertical mounting inside the distribution transformer tank to eliminate the difficulties associated with externally mounted arresters.

In recent years, under-oil arresters have gained increased acceptance due to the distinct advantage the under oil environment offers. When placed under oil the MOV arrester benefits from the cooling effect of the circulating oil. In addition, under-oil mounting of the arrester eliminates the possibility of shortened arrester life due to high surface contamination, wildlife, vandalism or moisture ingress. The under-oil arrester also offers improved transformer protection since internal mounting eliminates the need for long lead lengths to the arrester.

When properly coordinated with a current-limiting fuse, cover retention can be maintained through 50,000 A of available fault current. The AZU under-oil MOV arrester is available in ratings of 3 through 36 kV.

## Production tests

A complete production test program ensures a quality product. Each VariSTAR metal oxide varistor receives a series of 100% electrical tests. Quality is further ensured by a series of destructive tests performed on every batch of varistors. Listed are the tests that are performed on the varistors:

- 100% Physical Inspection
- 100% Discharge Voltage Test
- 100%  $V1\text{mA}/\text{cm}^2$
- 100% Leakage Current at 80% of  $V1\text{mA}/\text{cm}^2$  Voltage
- Batch High-current Short-duration Test
- Batch Thermal Stability Test

Each AZU arrester must pass the following production tests:

- 100% Physical Inspection
- 100% Leakage Current Test
- 100% RIV Test

**EATON**

Powering Business Worldwide

## Features and detailed description

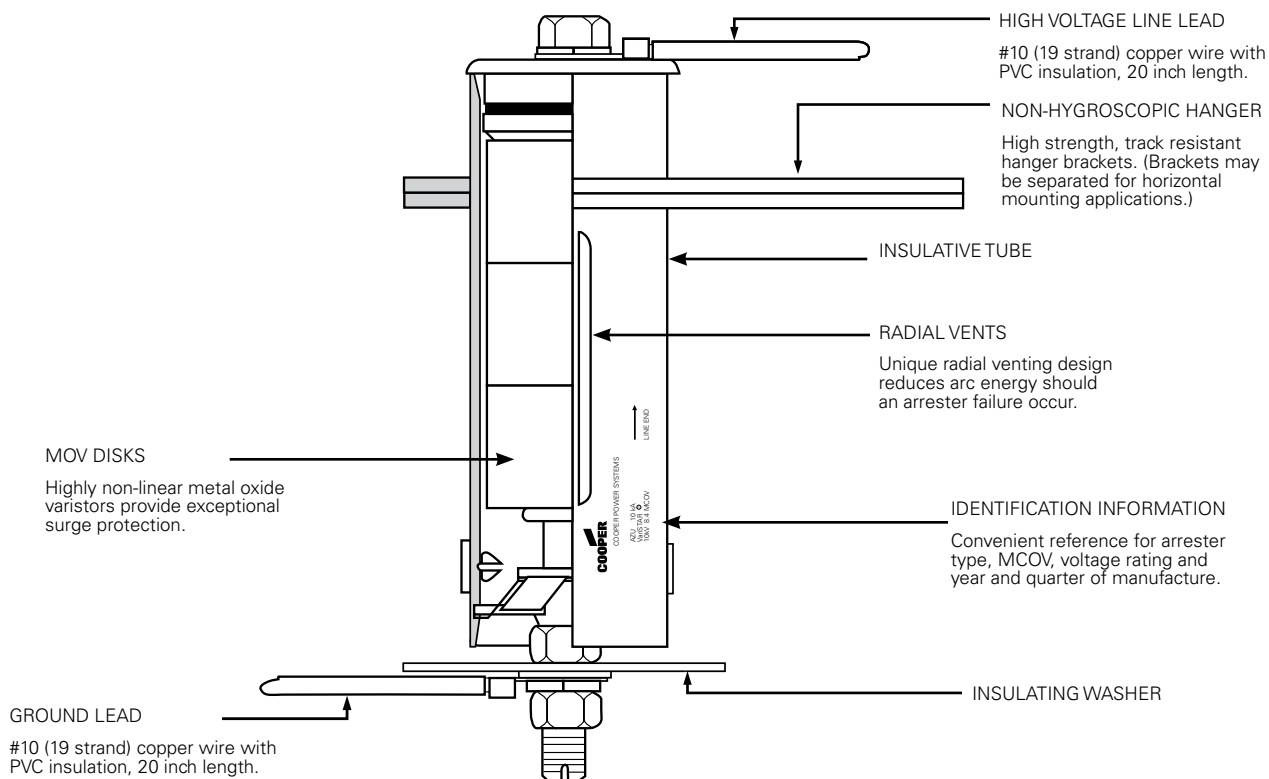

Figure 1. Cutaway illustration of VariSTAR Type AZU100L arrester.

Note: Optional design available with adaptor terminals (see Figure 4).

Table 1. Protective Characteristics

Arrester Rating (kV rms)	MCOV (kV rms)	Front-of-Wave Protective Level* (kV crest)	Maximum Discharge Voltage 8/20 $\mu$ s Current Wave (kV crest)						Switching Surge** (kV crest)
			1.5 kA	3 kA	5 kA	10 kA	20 kA	40 kA	
3	2.55	10.7	8.2	8.7	9.2	10.0	11.3	13.6	7.4
6	5.10	21.4	16.4	17.4	18.4	20.0	22.5	27.1	14.7
9	7.65	32.1	24.5	26.1	27.5	30.0	33.8	40.7	22.1
10	8.40	35.3	27.0	28.7	30.3	33.0	37.2	44.7	24.3
12	10.2	42.8	32.7	34.7	36.7	40.0	45.0	54.2	29.4
15	12.7	53.5	40.9	43.4	45.9	50.0	56.3	67.8	36.8
18	15.3	64.2	49.1	52.1	55.1	60.0	67.6	81.4	44.1
21	17.0	74.9	57.3	60.8	64.3	70.0	78.8	94.9	51.5
24	19.5	84.3	64.4	68.4	72.3	78.8	88.7	106.8	57.9
27	22.0	95.2	72.8	77.3	81.7	89.0	100.2	120.7	65.5
30	24.4	105.9	81.0	86.0	90.9	99.0	111.5	134.2	72.8
36	30.4	124.8	95.4	101.3	107.0	116.0	131.3	158.1	85.8

\* Based on 10 kA current impulse that results in a discharge voltage cresting in 0.5  $\mu$ s.

\*\* 45-60  $\mu$ s rise time 500 A current surge.

Table 2. Performance Test Characteristics\*

Description	Characteristics
Duty Cycle	20 current surges of 10 kA crest 8/20 $\mu$ s waveshape followed by 2 current surges of 40 kA crest 8/20 $\mu$ s waveshape
High-current, Short-duration Discharge	2 current surges of 100 kA crest 4/10 $\mu$ s waveshape
Low-current, Long-duration Discharge	20 current surges of 250 A crest 2000 $\mu$ s rectangular wave duration

\* Per latest revision of IEEE Std C62.11<sup>TM</sup>-1987 standard.

**Table 3. Commonly Applied Voltage Ratings of the Type AZU Arrester**

System Voltage (kV rms)		Recommended Arrester Rating (kV rms)		
Nominal	Maximum	Four-Wire Wye; Multi-Grounded Neutral	Three-Wire Wye; Solidly Grounded Neutral	Delta and Ungrounded Wye
2.4	2.54	—	—	3
4.16Y/2.4	4.4Y/2.54	3	6	6
4.16	4.4	—	—	6
4.8	5.08	—	—	6
6.9	7.26	—	—	9
8.32Y/4.8	8.8Y/5.08	6	9	—
12.0Y/6.93	12.7Y/7.33	9	12	—
12.47Y/7.2	13.2Y/7.62	9	15	—
13.2Y/7.62	13.97Y/8.07	10	15	—
13.8Y/7.97	14.52Y/8.38	10	15	—
13.8	14.52	—	—	18
20.78Y/12.0	22Y/12.7	15	21	—
22.86Y/13.2	24.2Y/13.87	18	24	—
23	24.34	—	—	27
24.94Y/14.4	26.4Y/15.24	18	27	—
27.6Y/15.93	29.3Y/16.89	21	30	—
34.5Y/19.92	36.5Y/21.08	27	36	—
46Y/26.6	48.3Y/28	36	—	—

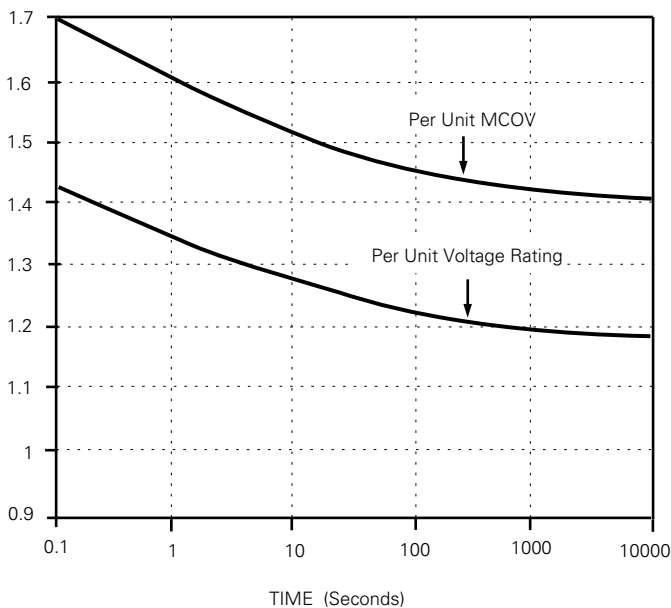

**Figure 2. Temporary overvoltage curve. No prior duty — 100 C ambient.**

**Standards**

The VariSTAR Type AZU arrester complies with the latest revision of IEEE Std C62.11™-1987 standard, "IEEE Standard for Metal Oxide Surge Arresters for AC Power Circuits".

**General application recommendations**

The rating of an arrester is the power frequency line-to-ground voltage at which the arrester is designed to pass an operating duty-cycle test. Table 3 provides a general application guide for the selection of the proper arrester rating for a given system voltage and system grounding configuration.

Eaton application engineers are available to make application recommendations. The following information is normally required:

1. System maximum operating voltage.
2. System grounding conditions.
  - A. For four-wire circuits, grounding conditions depend upon whether the system is multi-grounded, has a neutral impedance and whether common primary and secondary neutrals are used.
  - B. For three-wire circuits, grounding conditions depend upon whether the system is solidly grounded at the source, grounded through neutral impedance at the source transformers, or ungrounded.

Where unusual conditions exist (high ground resistance, high capacitive load, arc-welding equipment, etc.) the following supplementary information is necessary:

1. The unusual condition.
2. Type of construction, phase spacing, length of line, conductor size.
3. BIL of equipment and line insulation.
4. Phase-sequence components of impedances on the load side of the distribution substation.

The impedance of the transformer and the impedance and grounding of supply to the substation all affect the voltage during faults.

**Temporary overvoltage (TOV) capability**

The Temporary Overvoltage (TOV) capability of the AZU arrester is shown in Figure 2.

**Ordering information**

To order a VariSTAR Type AZU arrester, determine the arrester rating for the intended application using Table 3 and specify the appropriate catalog number from Table 5. Contact your Eaton representative for applications not listed.

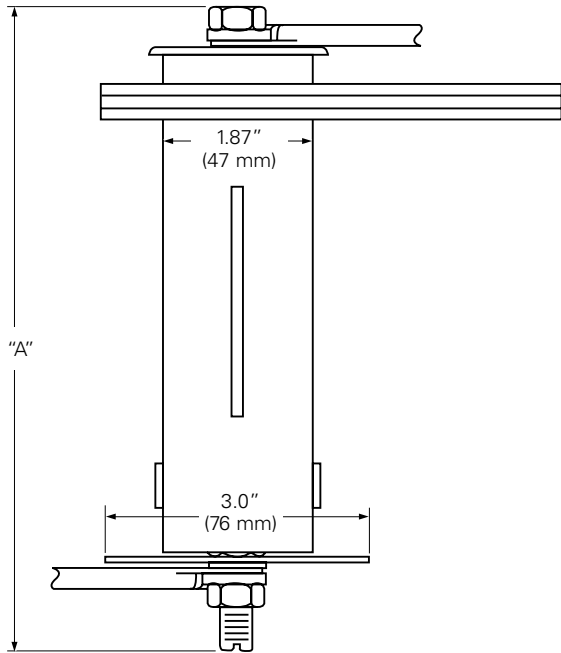

Figure 3. Dimensional information of VariSTAR Type AZU100L arresters.

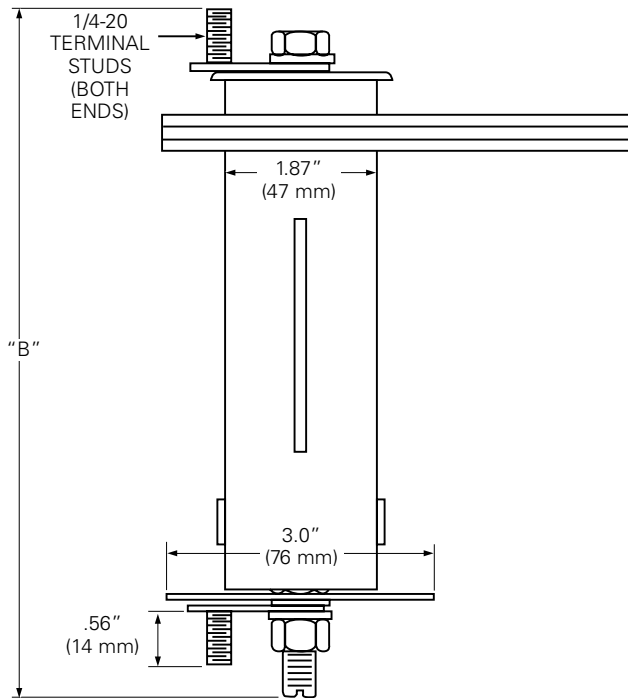

Figure 4. Dimensional information of VariSTAR Type AZU101L arresters.

Table 4. AZU Arrester Dimensional Information

Arrester Rating (kV rms)	Dimensions	
	A* in. (mm)	B** in. (mm)
3	5.0 (127)	5.3 (135)
6	6.4 (163)	6.7 (171)
9	6.4 (163)	6.7 (171)
10	6.4 (163)	6.7 (171)
12	7.8 (198)	8.1 (206)
15	7.8 (198)	8.1 (206)
18	9.1 (231)	9.4 (239)
21	9.1 (231)	9.4 (239)
24	10.5 (267)	10.8 (275)
27	10.5 (267)	10.8 (275)
30	11.9 (302)	12.2 (310)
36	13.2 (335)	13.5 (343)

\* Dimension A from Figure 3. (Reference only.)

\*\* Dimension B from Figure 4. (Reference only.)

Table 5. Catalog Numbers for AZU Arrester with 20" Line/ Ground Leads\*

Arrester Rating	Catalog Number
3	AZU100L003
6	AZU100L006
9	AZU100L009
10	AZU100L010
12	AZU100L012
15	AZU100L015
18	AZU100L018
21	AZU100L021
24	AZU100L024
27	AZU100L027
30	AZU100L030
36	AZU100L036

\* See Figure 3.

Table 6. Catalog Numbers for AZU Arrester Without Line/ Ground Leads\*

Arrester Rating	Catalog Number
3	AZU101L003
6	AZU101L006
9	AZU101L009
10	AZU101L010
12	AZU101L012
15	AZU101L015
18	AZU101L018
21	AZU101L021
24	AZU101L024
27	AZU101L027
30	AZU101L030
36	AZU101L036

\* With adapter terminals (see Figure 4).

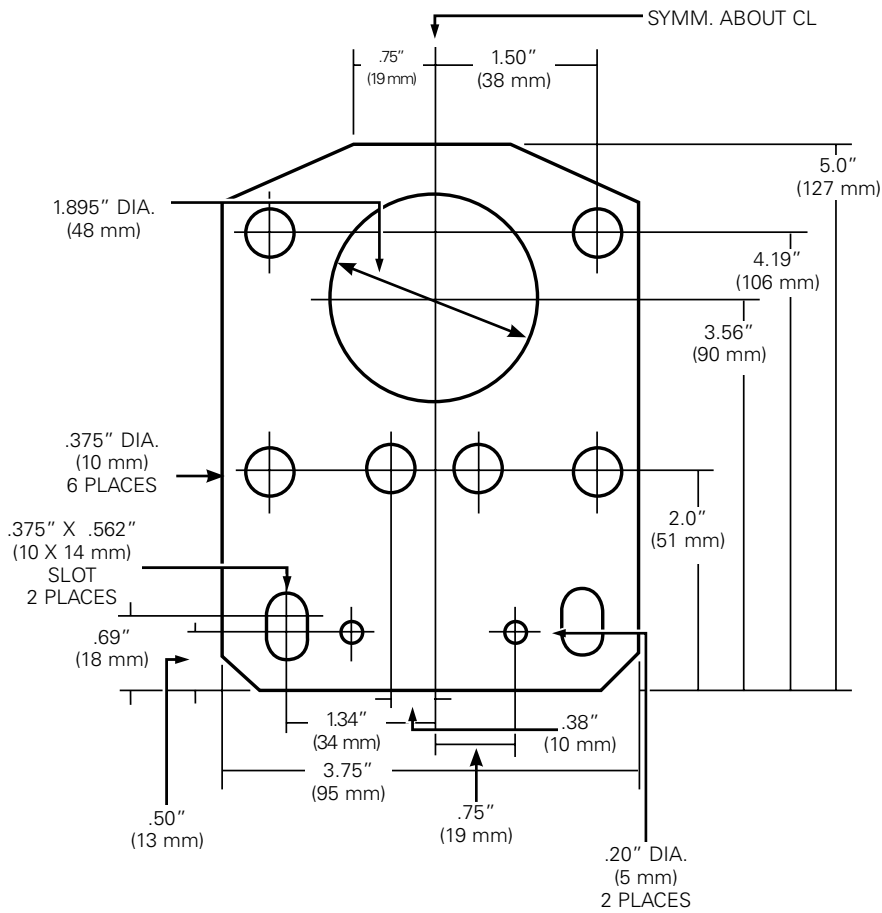

**Figure 5. Dimensional information of mounting bracket.**

**Note:** Hanger material thickness is 0.125 inches (3 mm). Dimensions given are for reference only.

This page is intentionally left blank.

This page is intentionally left blank.

**Eaton**  
1000 Eaton Boulevard  
Cleveland, OH 44122  
United States  
Eaton.com

**Eaton's Cooper Power Systems Division**  
2300 Badger Drive  
Waukesha, WI 53188  
United States  
Eaton.com/cooperpowerseries

© 2015 Eaton  
All Rights Reserved  
Printed in USA  
Publication No. CA235016EN

Eaton, Cooper Power, and VariSTAR are valuable trademarks of Eaton in the U.S. and other countries. You are not permitted to use these trademarks without the prior written consent of Eaton.  
IEEE Std C62.11™-1987 standard is a trademark of the Institute of Electrical and Electronics Engineers, Inc., (IEEE). This publication is not endorsed or approved by the IEEE.

For Eaton's Cooper Power series VariSTAR surge arrester product information call 1-877-277-4636 or visit:  
[www.eaton.com/cooperpowerseries](http://www.eaton.com/cooperpowerseries).