

## VariSTAR® Type AZU Heavy-Duty Distribution Class Under-Oil Arrester Installation Instructions



## **DISCLAIMER OF WARRANTIES AND LIMITATION OF LIABILITY**

The information, recommendations, descriptions and safety notations in this document are based on Eaton Corporation's ("Eaton") experience and judgment and may not cover all contingencies. If further information is required, an Eaton sales office should be consulted. Sale of the product shown in this literature is subject to the terms and conditions outlined in appropriate Eaton selling policies or other contractual agreement between Eaton and the purchaser.

THERE ARE NO UNDERSTANDINGS, AGREEMENTS, WARRANTIES, EXPRESSED OR IMPLIED, INCLUDING WARRANTIES OF FITNESS FOR A PARTICULAR PURPOSE OR MERCHANTABILITY, OTHER THAN THOSE SPECIFICALLY SET OUT IN ANY EXISTING CONTRACT BETWEEN THE PARTIES. ANY SUCH CONTRACT STATES THE ENTIRE OBLIGATION OF EATON. THE CONTENTS OF THIS DOCUMENT SHALL NOT BECOME PART OF OR MODIFY ANY CONTRACT BETWEEN THE PARTIES.

In no event will Eaton be responsible to the purchaser or user in contract, in tort (including negligence), strict liability or otherwise for any special, indirect, incidental or consequential damage or loss whatsoever, including but not limited to damage or loss of use of equipment, plant or power system, cost of capital, loss of power, additional expenses in the use of existing power facilities, or claims against the purchaser or user by its customers resulting from the use of the information, recommendations and descriptions contained herein. The information contained in this manual is subject to change without notice.

**Contents**

**DISCLAIMER OF WARRANTIES AND LIMITATION OF LIABILITY . . . . . ii**

**SAFETY FOR LIFE . . . . . iv**

**SAFETY INFORMATION . . . . . iv**

    Safety instructions . . . . . iv

**GENERAL . . . . . 1**

**INSPECTION AND ARRESTER CARE . . . . . 1**

**INSTALLATION . . . . . 1**

**APPLICATION . . . . . 3**



## Safety for life



Eaton meets or exceeds all applicable industry standards relating to product safety in its Cooper Power™ series products. We actively promote safe practices in the use and maintenance of our products through our service literature, instructional training programs, and the continuous efforts of all Eaton employees involved in product design, manufacture, marketing, and service.

We strongly urge that you always follow all locally approved safety procedures and safety instructions when working around high voltage lines and equipment, and support our “Safety For Life” mission.

## Safety information

The instructions in this manual are not intended as a substitute for proper training or adequate experience in the safe operation of the equipment described. Only competent technicians who are familiar with this equipment should install, operate, and service it.

A competent technician has these qualifications:

- Is thoroughly familiar with these instructions.
- Is trained in industry-accepted high and low-voltage safe operating practices and procedures.
- Is trained and authorized to energize, de-energize, clear, and ground power distribution equipment.
- Is trained in the care and use of protective equipment such as arc flash clothing, safety glasses, face shield, hard hat, rubber gloves, clampstick, hotstick, etc.

Following is important safety information. For safe installation and operation of this equipment, be sure to read and understand all cautions and warnings.

### Hazard Statement Definitions

This manual may contain four types of hazard statements:

---

 **DANGER**

Indicates an imminently hazardous situation which, if not avoided, will result in death or serious injury.

---

 **WARNING**

Indicates a potentially hazardous situation which, if not avoided, could result in death or serious injury.

---

 **CAUTION**

Indicates a potentially hazardous situation which, if not avoided, may result in minor or moderate injury.

---

**CAUTION**

Indicates a potentially hazardous situation which, if not avoided, may result in equipment damage only.

---

### Safety instructions

Following are general caution and warning statements that apply to this equipment. Additional statements, related to specific tasks and procedures, are located throughout the manual.

---

 **DANGER**

**Hazardous voltage. Contact with hazardous voltage will cause death or severe personal injury. Follow all locally approved safety procedures when working around high- and low-voltage lines and equipment.**

G103.3

---

 **WARNING**

**Before installing, operating, maintaining, or testing this equipment, carefully read and understand the contents of this manual. Improper operation, handling or maintenance can result in death, severe personal injury, and equipment damage.**

G101.0

---

 **WARNING**

**This equipment is not intended to protect human life. Follow all locally approved procedures and safety practices when installing or operating this equipment. Failure to comply can result in death, severe personal injury and equipment damage.**

G102.1

---

 **WARNING**

**Power distribution and transmission equipment must be properly selected for the intended application. It must be installed and serviced by competent personnel who have been trained and understand proper safety procedures. These instructions are written for such personnel and are not a substitute for adequate training and experience in safety procedures. Failure to properly select, install or maintain power distribution and transmission equipment can result in death, severe personal injury, and equipment damage.**

G122.2

---

**⚠ CAUTION**

---

**VariSTAR Type AZU arresters should be installed only by personnel familiar with good safety practice and the handling of high-voltage electrical equipment.**

---

## General

Eaton's Cooper Power series VariSTAR Type AZU heavy-duty distribution class under-oil arrester is designed to be mounted inside of a padmounted or poletype distribution transformer tank. Internal, under-oil mounting of the arrester eliminates the possibility of shortened arrester life due to high surface contamination, wildlife, vandalism or moisture ingress. In addition, the under-oil arrester offers improved transformer protection since internal mounting eliminates the need for long lead lengths to the arrester.

## Inspection and arrester care

Severe handling and shipping conditions may damage the unit and cause premature arrester failure. If there is evidence of physical damage, the unit should not be installed unless approved by your Eaton representative.

Product name, rating and maximum continuous operating voltage are identified on the housing. If this information does not match the shipping order, contact your Eaton representative before installation.

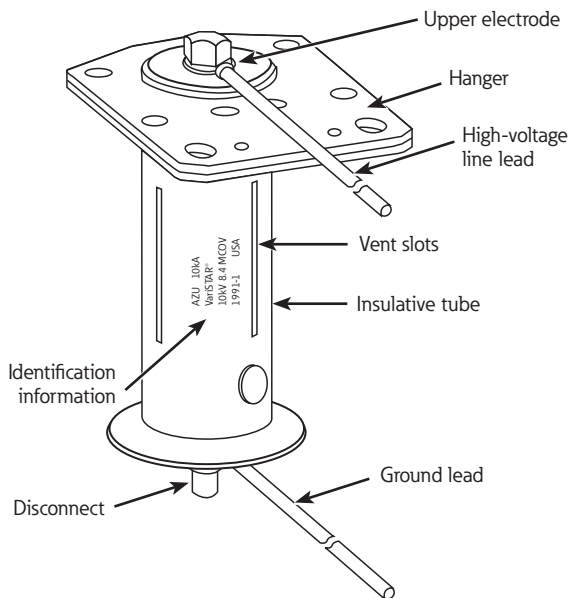

**Figure 1. Vertical Mounted VariSTAR Type AZU Arrester**

## Installation

The Type AZU under-oil arrester is designed to be mounted from its high strength, non-hygroscopic hanger shown in Figure 2. Figure 3 and Figure 4 show the recommended vertical and horizontal mounting configurations. The mounting bracket can be mounted to a grounded surface provided the creepage distance along the bracket is at least 1.75 inches (44 mm) from the arrester housing. When so installed, the arrester body should be at least 0.90 inches (23 mm) from any grounded surface. This will ensure an installation withstand level of 170 kV crest (1.2/50  $\mu$ s).

The high voltage line lead has been attached to the high voltage electrode at the factory. In this unit configuration, the upper electrode is firmly attached to the insulative tube in such a manner that the lead is captivated. This line may be tied to the insulative bracket to further secure the lead so that it will not contact a ground surface.

The ground lead is attached to the disconnect and is mounted such that neither the disconnect nor the lead can contact an energized surface during operation. This lead should have lateral forces of less than 10 lbs. when installed.

---

**⚠ WARNING**

---

**Be sure to follow all locally approved installation procedures and safety practices when installing this equipment. Improper installation may result in severe personal injury and equipment damage.**

---

VariSTAR® Type AZU Heavy-Duty Distribution Class Under-Oil Arrester

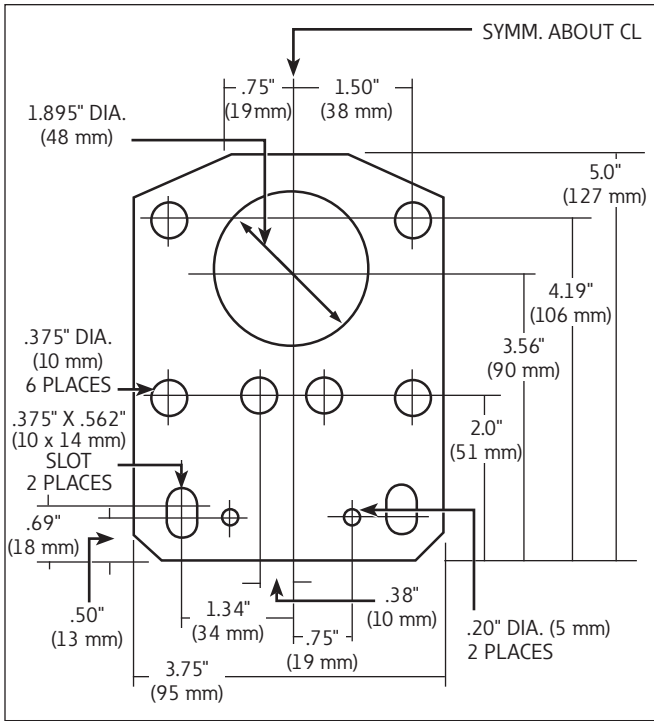

Figure 2. Mounting bracket dimensions

**Note:** Hanger material thickness is 0.125 inches (3 mm).  
Dimensions given are for reference only.

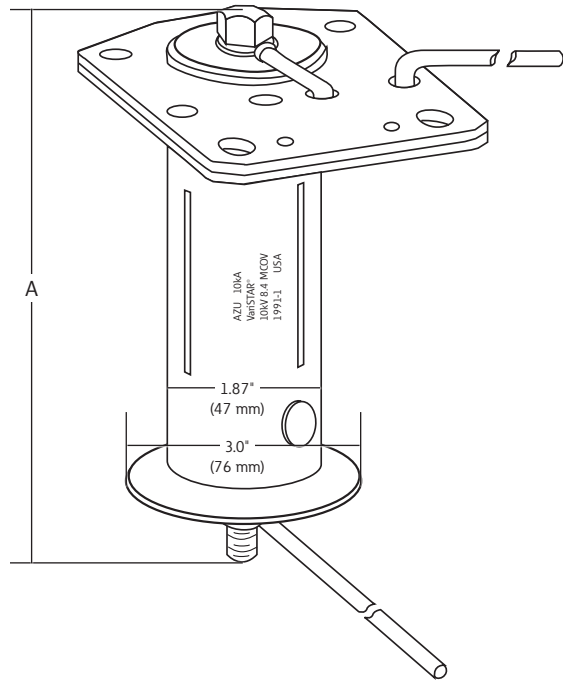

Figure 3. Type AZU arrester vertical mounting with dimensions

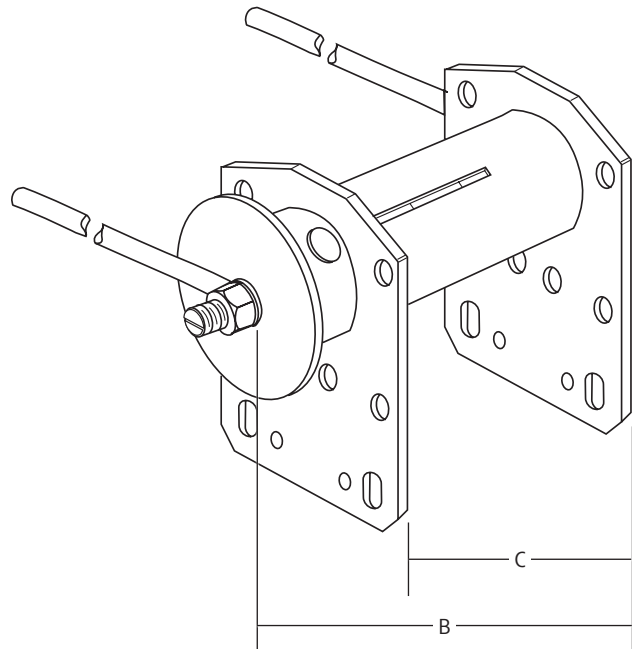

Figure 4. Type AZU arrester horizontal mounting configuration

# VariSTAR® Type AZU Heavy-Duty Distribution Class Under-Oil Arrester

The arrester is designed such that, in the event of failure, the housing will remain intact and firmly attached to the upper electrode. The disconnect at the bottom of the arrester will operate at 1250 amps and above when used with properly sized fuses. The disconnect will operate and the internal disks will drop to the bottom of the tank. This will result in an open circuit between the line terminal and ground. Tests have indicated that the slots in the side of the insulative body will dampen the forces to the surrounding insulating liquid and prevent any fragmentation of internal components to adjacent components such as core and coils.

---

## WARNING

---

**The transformer should not be tested (impulse or hipot) with the arrester connected. If the transformer is impulse tested with the arrester installed, the arrester will clamp the discharge voltage. If the unit is connected to the transformer during a hipot test, there is a possibility that the arrester will be damaged.**

---

The Type AZU arrester is designed to operate when submerged in transformer oil. It is recommended that the average oil temperature does not exceed 90° C and that the maximum oil temperature does not exceed 125° C.

## Application

The Type AZU arrester should be installed only on systems where the power frequency voltage at the arrester does not exceed published maximum continuous operating voltages (MCOV) values. MCOV values are shown in Table 1 and are also marked on the arrester housing.

**Table 1. Type AZU arrester dimensions**

Arrester Rating (kV rms)	MCOV (kV rms)	Dimensions* in inches (mm)			Type AZU Arrester Catalog Number
		A	B	C	
3	2.55	4.8 (122)	3.4 (86)	2.3 (58)	AZU100L003
6	5.10	5.9 (150)	4.5 (114)	3.4 (86)	AZU100L006
9	7.65	7.0 (178)	5.6 (142)	4.5 (114)	AZU100L009
10	8.40	7.0 (178)	5.6 (142)	4.5 (114)	AZU100L010
12	10.20	8.2 (208)	6.8 (173)	5.7 (145)	AZU100L012
15	12.70	9.3 (236)	7.9 (201)	6.8 (173)	AZU100L015
18	15.30	10.3 (262)	8.9 (226)	7.8 (198)	AZU100L018
21	17.00	11.5 (292)	10.1 (257)	9.0 (229)	AZU100L021
24	19.50	11.5 (292)	10.1 (257)	9.0 (229)	AZU100L024
27	22.00	12.7 (323)	11.3 (287)	10.2 (259)	AZU100L027

\* Refer to Figure 3 and Figure 4 for dimension references.



**Eaton**  
1000 Eaton Boulevard  
Cleveland, OH 44122  
United States  
Eaton.com

**Eaton's Power Systems Division**  
2300 Badger Drive  
Waukesha, WI 53188  
United States  
Eaton.com/cooperpowerseries

© 2016 Eaton  
All Rights Reserved  
Printed in USA  
Publication No. MN235025EN  
November 2016

Eaton is a registered trademark.

All trademarks are property  
of their respective owners.

For Eaton's Cooper Power series product  
information  
call 1-877-277-4636 or visit:  
[www.eaton.com/cooperpowerseries](http://www.eaton.com/cooperpowerseries).