

VariSTAR™ Type AZL heavy-duty distribution-class MOV arrester



General

Eaton incorporates the latest in metal oxide varistor (MOV) technology in a porcelain design with its Cooper Power™ series VariSTAR™ Type AZL heavy-duty distribution-class MOV arrester in ratings of 3 through 36 kV. With this combination of technologies, Eaton can offer reliable and cost effective overhead protection of distribution systems.

Construction

The VariSTAR Type AZL arrester consists of highly nonlinear metal oxide varistors enclosed in a porcelain housing. The highly nonlinear nature of the MOV disks results in conduction of leakage current of milliamperes at nominal line-to-ground operating voltage. This small amount of leakage current (which is primarily capacitive current with a small component of resistive current) can be tolerated on a continuous basis.

The VariSTAR Type AZL design is available with or without an isolator and can be supplied with a variety of mounting brackets to satisfy a wide range of applications.

Operation

The operation of the VariSTAR Type AZL is typical of gapless metal oxide arresters. During steady state conditions, nominal line-to-ground voltage is applied continuously across the arrester's terminals. When overvoltages occur, the VariSTAR Type AZL arrester limits the overvoltage to required protective levels by conducting the surge current. Upon passage of the overvoltage condition, the arrester returns to a highly nonlinear steady state, conducting minimal leakage current.

The superior protective characteristics of the VariSTAR Type AZL arrester provide excellent protection for distribution transformers with lower impulse withstand capabilities. Its superior reliability makes it an ideal choice for areas with high isokeraunic levels.

EATON

Powering Business Worldwide

Features and detailed description

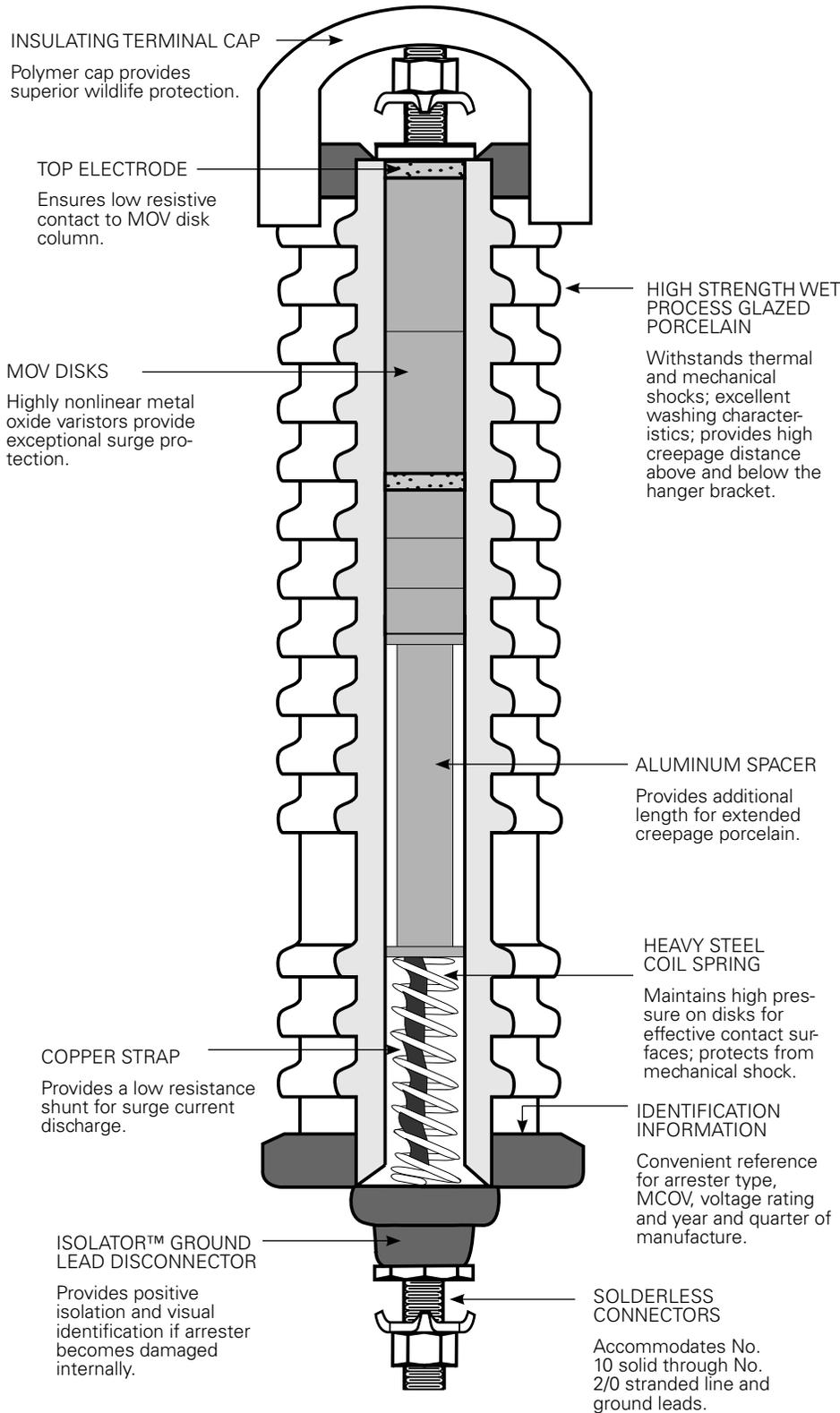

Figure 1. Cutaway illustration of VariSTAR AZL arrester.

Production tests

A complete production test program ensures a quality product. Each VariSTAR metal oxide varistor receives a series of electrical tests. Quality is further ensured by a series of destructive tests performed on every batch of varistors. Listed are the tests that are performed on the varistors:

- 100% Physical Inspection
- 100% Discharge Voltage Test
- 100% $V1mA/cm^2$
- 100% Leakage Current at 80% of $V1mA/cm^2$ Voltage
- Batch High-current, Short-duration Test
- Batch Thermal Stability Test
- Batch Disk Aging Test

Each VariSTAR Type AZL arrester must pass the following production tests:

- 100% Physical Inspection
- 100% Vacuum over Fluid Seal Test
- 100% Leakage Current Test
- 100% RIV Test

Standards

The VariSTAR Type AZL arrester complies with the latest revision of IEEE Std C62.11™-1987 standard "IEEE Standard for Metal Oxide Surge Arresters for AC Power Circuits".

General application recommendations

The rating of an arrester is the power frequency line-to-ground voltage at which the arrester is designed to pass an operating duty-cycle test. Table 1 provides a general application guide for the selection of the proper arrester rating for a given system voltage and system grounding configuration.

Eaton's application engineers are available to make recommendations. The following information is normally required:

1. System maximum operating voltage.
2. System grounding conditions.
 - A. For four-wire circuits, grounding conditions depend upon whether the system is multi-grounded, whether it has a neutral impedance and whether common primary and secondary neutrals are used.
 - B. For three-wire circuits, grounding conditions depend upon whether the system is solidly grounded at the source, grounded through neutral impedance at the source transformers or ungrounded.

Table 1. Commonly Applied Voltage Ratings of the VariSTAR AZL Arrester

System Voltage (kV rms)		Recommended Arrester Rating (kV rms)		
Nominal	Maximum	Four-Wire Wye Multi-Grounded Neutral	Three-Wire Wye Solidly Grounded Neutral	Delta and Ungrounded Wye
2.4	2.54	–	–	3
4.16Y/2.4	4.4Y/2.54	3	6	6
4.16	4.4	–	–	6
4.8	5.08	–	–	6
6.9	7.26	–	–	9
8.32Y/4.8	8.8Y/5.08	6	9	–
12.0Y/6.93	12.7Y/7.33	9	12	–
12.47Y/7.2	13.2Y/7.62	9	15	–
13.2Y/7.62	13.97Y/8.07	10	15	–
13.8Y/7.97	14.52Y/8.38	10	15	–
13.8	14.52	–	–	18
20.78Y/12.0	22Y/12.7	15	21	–
22.86Y/13.2	24.2Y/13.87	18	24	–
23	24.34	–	–	30
24.94Y/14.4	26.4Y/15.24	18	27	–
27.6Y/15.93	29.3Y/16.89	21	30	–
34.5Y/19.92	36.5Y/21.08	27	36	–
46Y/26.6	48.3Y/28	36	–	–

Where unusual conditions exist (high ground resistance, high capacitive load, arc-welding equipment, etc.) the following supplementary information is necessary:

1. The unusual condition.
2. Type of construction, phase spacing, length of line, conductor size.
3. BIL of equipment and line insulation.
4. Phase-sequence components of impedances on the load side of the distribution substation.

The impedance of the transformer and the impedance and grounding of supply to the substation all affect the voltage during faults.

The Temporary Overvoltage (TOV) capability of the VariSTAR AZL arrester is shown in Figure 2.

Performance test characteristics

The VariSTAR AZL arrester consistently withstands the following design tests as described by IEEE Std C62.11™-1987 standard:

Duty cycle

20 current surges of 10 kA crest 8/20 μs waveshape followed by 2 current surges of 40 kA crest 8/20 μs waveshape.

High-current, short-duration discharge:

2 current surges of 100 kA crest 4/10 μs waveshape.

Low-current, long-duration discharge:

20 current surges of 250 A crest 2000 μs rectangle wave duration.

Following each of these tests, the arresters remain thermally stable as verified by:

- Continually decreasing power values during a thirty minute power monitoring period.
- No evidence of physical or electrical deterioration.
- The 10 kA (8/20 μs) discharge voltages measured after each test changed by less than 10% from the initial values.

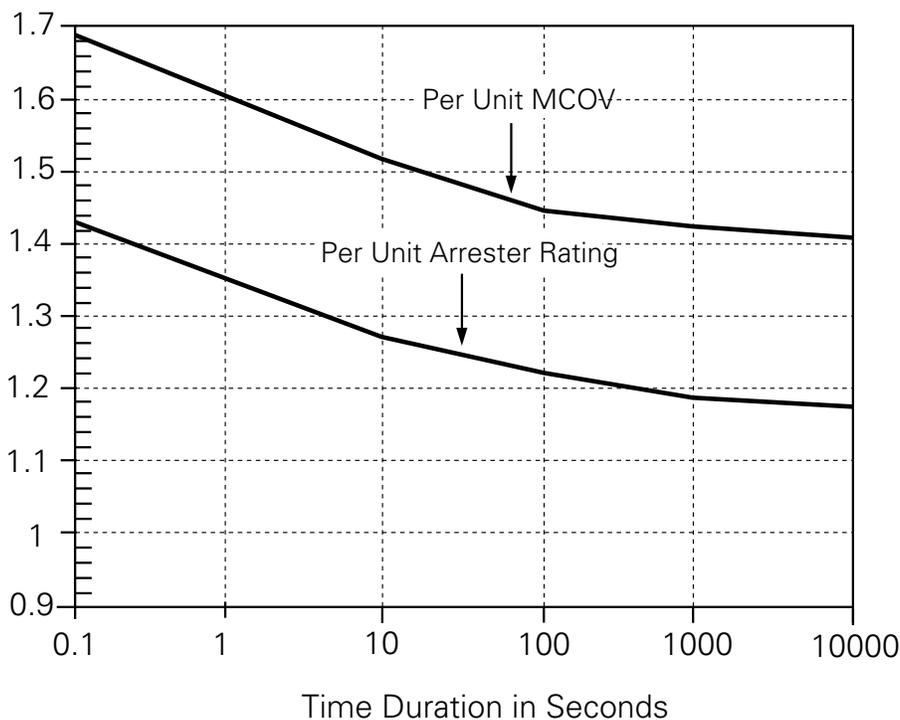

Figure 2. Temporary overvoltage curve. No prior duty – 60° C ambient.

Effective February 2015

Protective characteristics

The protective characteristics of the VariSTAR AZL arresters are shown in Table 2.

Table 2. Protective Characteristics

Arrester Rating (kV rms)	MCOV (kV rms)	Front-of-wave Protective Level* (kV crest)	Maximum Discharge Voltage (kV crest) 8/20 μ s Current Wave					
			1.5 kA	3 kA	5 kA	10 kA	20 kA	40 kA
3	2.55	10.7	8.2	8.7	9.2	10.0	11.3	13.6
6	5.10	21.4	16.4	17.4	18.4	20.0	22.5	27.1
9	7.65	32.1	24.5	26.1	27.5	30.0	33.8	40.7
10	8.40	35.3	27.0	28.7	30.3	33.0	37.2	44.7
12	10.20	42.8	32.7	34.7	36.7	40.0	45.0	54.2
15	12.70	53.5	40.9	43.4	45.9	40.0	56.3	67.8
18	15.30	64.2	49.1	52.1	55.1	60.0	67.6	81.4
21	17.00	74.9	57.3	60.8	64.3	70.0	78.8	94.9
24	19.50	84.3	64.4	68.4	72.3	78.8	88.7	106.8
27	22.00	95.2	72.8	77.3	81.7	89.0	100.2	120.7
30	24.40	105.9	81.0	86.0	90.9	99.0	111.5	134.2
36	29.00	124.8	95.4	101.3	107.0	116.6	131.3	158.1

* Based on 10 kA current impulse that results in a discharge voltage cresting in 0.5 μ s.

Insulation characteristics

The insulation characteristics of the VariSTAR AZL arresters are shown in Table 3.

Table 3. Insulation Characteristics

Arrester Rating (kV rms)	Creepage		Strike		Insulation Withstand Voltages		
	(in.)	(cm)	(in.)	(cm)	1.2/50 μ s Impulse (kV crest)	1 min. Dry (kV rms)	10 sec. Wet (kV rms)
3	2.8	7.1	2.0	5.1	45	15	13
6	6.6	16.8	4.5	11.4	60	21	20
9	10.4	26.4	7.0	17.8	75	27	24
10	10.4	26.4	7.0	17.8	75	27	24
12	13.2	33.5	8.9	22.6	95	35	30
15	13.2	33.5	8.9	22.6	95	35	30
18	17.9	45.5	12.0	30.5	125	42	36
21	17.9	45.5	12.0	30.5	125	42	36
24	21.7	55.1	14.4	36.6	150	70	60
27	21.7	55.1	14.4	36.6	150	70	60
30*	26.4	67.1	17.5	44.5	200	95	80
36*	26.4	67.1	17.5	44.5	200	95	80

* Not applicable to AZL19C Series.

Dimensions and clearances

The dimensions and clearances of the VariSTAR AZL arresters are shown in Figures 3, 4 and 5.

Arrester Rating (kV rms)	Dimensions				Minimum Recommended Clearances*			
	A		B		Phase-to-Ground		Phase-to-Phase	
	(in.)	(cm)	(in.)	(cm)	(in.)	(cm)	(in.)	(cm)
3	9.19	23.3	5.20	13.2	3.4	8.6	5.2	13.2
6	11.67	29.6	5.20	13.2	4.4	11.2	6.5	16.5
9	14.77	37.5	5.82	14.8	5.6	14.2	8.0	20.3
10	14.77	37.5	5.82	14.8	5.6	14.2	8.0	20.3
12	17.25	43.8	6.44	16.4	6.4	16.3	8.7	22.1
15	17.25	43.8	6.44	16.4	7.1	18.0	9.7	24.6
18	20.97	53.3	7.06	17.9	9.6	24.4	12.2	31.0
21	20.97	53.3	7.06	17.9	9.6	24.4	12.2	31.0
24	24.07	61.1	7.68	19.5	11.1	28.2	14.2	36.1
27	24.07	61.1	7.68	19.5	11.1	28.2	14.2	36.1
30	27.79	70.6	8.30	21.1	11.1	28.2	14.2	36.1
36	27.79	70.6	8.30	21.1	13.1	33.3	17.2	43.7

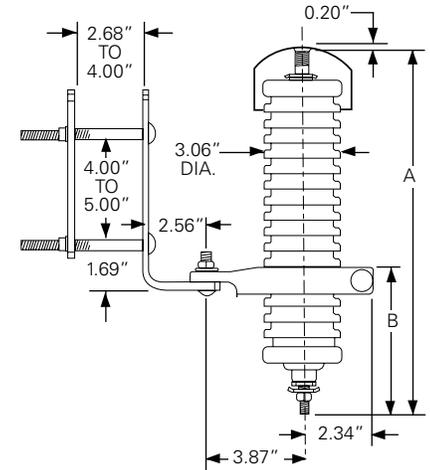

Figure 3. Dimensions for AZL1A, AZL1B, and AZL19B series.

* All clearances are measured from centerline of arrester per IEEE Std C62.11™-1987 standard.

Arrester Rating (kV rms)	Dimensions										Minimum Recommended Clearances*			
	A		B		C		D		E		Phase-to-Ground		Phase-to-Phase	
	(in.)	(cm)	(in.)	(cm)	(in.)	(cm)	(in.)	(cm)	(in.)	(cm)	(in.)	(cm)	(in.)	(cm)
3	9.19	23.3	5.20	13.2	6.04	15.3	10.77	27.4	4.12	10.5	3.4	8.6	5.2	13.2
6	11.67	29.6	5.20	13.2	8.52	21.6	13.25	33.7	4.12	10.5	4.5	11.4	6.5	16.5
9	14.77	37.5	5.82	14.8	11.00	27.9	15.73	40.0	4.12	10.5	5.6	14.2	8.0	20.3
10	14.77	37.5	5.82	14.8	11.00	27.9	15.73	40.0	4.12	10.5	5.6	14.2	8.0	20.3
12	17.25	43.8	6.44	16.4	12.86	32.7	17.59	44.7	4.12	10.5	6.4	16.3	8.7	22.1
15	17.25	43.8	6.44	16.4	12.86	32.7	17.59	44.7	4.12	10.5	7.1	18.0	9.7	24.6
18	20.97	53.3	7.06	17.9	15.96	40.5	20.69	52.6	4.12	10.5	9.6	24.4	12.2	31.0
21	20.97	53.3	7.06	17.9	15.96	40.5	20.69	52.6	4.12	10.5	9.6	24.4	12.2	31.0
24	24.07	61.1	7.68	19.5	18.44	46.8	23.17	58.9	4.12	10.5	11.1	28.2	14.2	36.1
27	24.07	61.1	7.68	19.5	21.22	53.9	32.20	81.8	4.38	11.1	11.1	28.2	14.2	36.1
30	27.79	70.6	8.3	21.1	24.32	61.8	35.30	89.7	4.38	11.1	11.1	28.2	14.2	36.1
36	27.79	70.6	8.30	21.1	24.32	61.8	35.30	89.7	4.38	11.1	13.1	33.3	17.2	43.7

Figure 4. Dimensions for AZL31B series.

Note: Columns B, C, & D are calculated with the bracket located at the top of the bellyband region.

Note: Mounting Lug Spacing for 3 through 24 kV is 2.5" (6.4 cm) and for 27 through 36 kV is 9.25" (23.5 cm).

*All clearances are measured from centerline of arrester per IEEE C62.11™-1987 standard..

IMPORTANT

The values shown in Figures 3, 4, and 5 are the minimum clearances recommended by Eaton. These clearances may be revised to meet local or system requirements for spacing or energized equipment. However, safe operating procedures must always be followed.

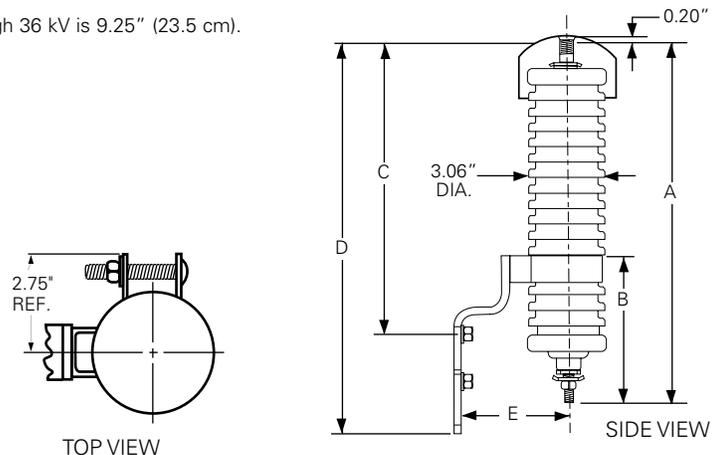

Minimum Recommended Clearances*

Arrester Rating (kV rms)	Enclosure Application								Dimensions			
	Phase-to-Ground		Phase-to-Phase		Phase-to-Ground		Phase-to-Phase		A		B	
	(in.)	(cm)	(in.)	(cm)	(in.)	(cm)	(in.)	(cm)	(in.)	(cm)	(in.)	(cm)
3	2.25	5.7	4.05	10.3	2.50	6.4	4.30	10.9	8.38	21.3	4.39	11.2
6	3.05	7.7	5.10	13.0	3.55	9.0	5.60	14.2	10.86	27.6	4.39	11.2
9	3.80	9.7	6.10	15.5	4.55	11.6	6.85	17.4	13.96	35.5	50.1	12.7
10	4.05	10.3	6.35	16.1	4.80	12.2	7.10	18.0	13.96	35.5	5.01	12.7
12	4.55	11.6	6.85	12.4	5.75	14.6	8.05	20.5	16.44	41.8	5.63	14.3
15	5.30	13.5	7.85	19.9	6.75	17.2	9.30	23.6	16.44	41.8	5.63	14.3
18	6.15	15.6	8.70	22.1	7.85	20.0	10.40	26.4	20.16	51.2	6.25	15.9
21	7.05	17.9	9.60	24.4	9.25	23.5	11.80	30.0	20.16	51.2	6.25	15.9
24	7.85	19.9	10.90	27.7	9.85	25.0	12.90	32.8	23.26	59.1	6.87	17.4
27	8.75	22.2	11.80	30.0	11.45	29.1	14.50	36.8	23.26	59.1	6.87	17.4

Figure 5. Dimensions for AZL19C series.

* All clearances are measured from centerline of arrester and are based upon the protective characteristics of the arrester.

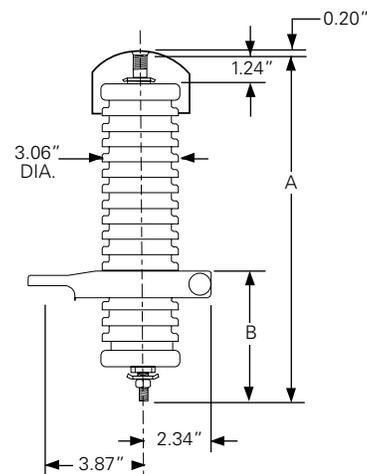

Ordering information

To order a VariSTAR AZL arrester, determine the voltage rating for the intended application using Table 1.

Specify the appropriate catalog number from Table 4. Contact an Eaton representative for applications not listed.

Table 4. Ordering Information

Catalog Numbers: VariSTAR Type AZL Arrester

Arrester Rating (kV rms)	Crossarm Bracket and 19.25" Line Lead	Without Crossarm Bracket	Crossarm Bracket	Transformer Mounting Bracket	Cubicle Mounted (Without Isolator)
3	AZL1A3R	AZL19B3R	AZL1B3R	AZL31B3R	AZL19C503R
6	AZL1A6R	AZL19B6R	AZL1B6R	AZL31B6R	AZL19C506R
9	AZL1A9R	AZL19B9R	AZL1B9R	AZL31B9R	AZL19C509R
10	AZL1A10R	AZL19B10R	AZL1B10R	AZL31B10R	AZL19C510R
12	AZL1A12R	AZL19B12R	AZL1B12R	AZL31B12R	AZL19C512R
15	AZL1A15R	AZL19B15R	AZL1B15R	AZL31B15R	AZL19C515R
18	AZL1A18R	AZL19B18R	AZL1B18R	AZL31B18R	AZL19C518R
21	AZL1A21R	AZL19B21R	AZL1B21R	AZL31B21R	AZL19C521R
24	AZL1A24R	AZL19B24R	AZL1B24R	AZL31B24R	AZL19C524R
27	AZL1A27R	AZL19B27R	AZL1B27R	AZL31B27R	AZL19C527R
30	AZL1A30R	AZL19B30R	AZL1B30R	AZL31B30R	
36	AZL1A36R	AZL19B36R	AZL1B36R	AZL31B36R	

This page is intentionally left blank.

Eaton
1000 Eaton Boulevard
Cleveland, OH 44122
United States
Eaton.com

Eaton's Cooper Power Systems Division
2300 Badger Drive
Waukesha, WI 53188
United States
Eaton.com/cooperpowerseries

© 2015 Eaton
All Rights Reserved
Printed in USA
Publication No. CA235006EN

Eaton, Cooper Power, Isolator, and VariSTAR are valuable trademarks of Eaton in the U.S. and other countries. You are not permitted to use these trademarks without the prior written consent of Eaton.
IEEE Std C62.11™-1987 standard is a trademark of the Institute of Electrical and Electronics Engineers, Inc., (IEEE). This publication is not endorsed or approved by the IEEE.

For Eaton's Cooper Power series VariSTAR AZL surge arrester product information call 1-877-277-4636 or visit: www.eaton.com/cooperpowerseries.

