

VariSTAR Type AZG3 Surge Arresters for Systems through 345 kV IEC 10-kA; Line Discharge Class 3



**Figure 1. VariSTAR Type AZG3 Surge Arrester,
 $U_r = 96$ kV.**

General

Eaton's Cooper Power series VariSTAR™ AZG3 Surge Arresters offer the latest in metal oxide varistor (MOV) technology for the economical protection of medium-voltage class power and substation equipment. These arresters are gapless and are constructed of a single series column of 63 mm diameter MOV disks. The arrester is designed and tested exclusively to the requirements of the International Electrotechnical Commission Standard IEC 99-4, and is available in ratings suitable for the transient overvoltage protection of electrical equipment on systems through 345 kV.

Eaton assures the design integrity of the Cooper Power series AZG3 arrester through a rigorous testing program conducted at the Thomas A. Edison Technical Center and at the factory in Olean, NY USA. The availability of complete "in-house" testing facilities assures that as continuous process improvements are made, they are professionally validated to the highest technical standards.

Construction

External

The wet-process porcelain housing features an alternating shed design ($U_r > 48$ kV) that provides excellent resistance to the effects of atmospheric housing contamination. AZG3 arresters are optionally available with extra creepage porcelains for use in areas with extreme conditions of natural atmospheric and man-made pollution.

The dielectric properties of the porcelain are coordinated with the electrical protective characteristics of the arrester in accordance with the requirements of IEC 99-4. The unit end castings are of a corrosion-resistant aluminum alloy configured for interchangeable mounting with many manufacturers' arresters for ease in upgrading to VariSTAR Arrester Technology. This three-footed mounting is provided on a 111 to 127 mm radius pattern for customer supplied 12 mm diameter hardware. High cantilever strength assures mechanical integrity. Housings are available in standard grey or optional brown glaze color.

Standard line and earth terminal connectors accommodate up to 335 mm² conductor. Insulating bases and discharge counters are optionally available for in-service monitoring of arrester discharge activity.

The end fittings and porcelain housing of each arrester unit are sealed and tested by means of a sensitive helium mass spectrometer; this assures that the quality and insulation protection provided by the arrester is never compromised over its lifetime by the entrance of moisture. A corrosion resistant nameplate is provided and contains all information required by IEC Standards; in addition, stacking arrangement information is provided for multi-unit arresters. Voltage grading rings are included for arresters rated 172 kV and above.

EATON

Powering Business Worldwide

Table 1.

System Application Voltages	3-345 kV
Rated Arrester Voltages, U_r	3-312 kV
Power System Frequency	50 or 60 Hz
Applicable Design and Test Standard	IEC 99-4
Nominal Discharge Current	10 kA
Line Discharge Class	3
High Current Withstand	100 kA
Pressure Relief Class	63 kA rms sym
Rated Discharge Energy	5.6 kJ/kV of U_c or 4.5 kJ/kV of U_r

Features and detailed description

Internal

The VariSTAR AZG3 arrester's reliability is enhanced by its totally gapless design. Gapless construction makes a significant contribution to the performance of arresters through the elimination of gap reseat as a consideration associated with the discharge of switching surge currents. The specially formulated metal-oxide varistors, manufactured under Eaton's exclusive quality control, provide exceptional non-linear protective characteristics, durability, and dependable energy dissipation capabilities.

Operation

The VariSTAR AZG3 Arrester conducts only a few milliamperes of leakage current when energized at normal system voltage. When an overvoltage event occurs, the arrester conducts only the current and consequently the energy necessary to limit the overvoltage to its protective level. By doing so it provides precise and predictable protection, minimizes the absorbed energy, and discharges no power frequency system currents.

VariSTAR Arresters are ideal for the protection of critical substation apparatus in areas of moderate lightning incidence and for protection against switching surges generated on transmission systems.

A controlled and directed pressure relief system is incorporated in the VariSTAR AZG3 Arrester Design. In the unlikely event of an arrester failure, this pressure venting system rapidly relieves internal pressure and transfers the internal arc to the outside of the arrester porcelain through vent ports in the end castings.

When called upon to operate, this mechanism vents internal pressures in fractions of a cycle preventing violent arrester failure. This mechanism is effective for system fault currents up to 63,000 amperes rms symmetrical (163,000 A first crest).

General application recommendations

The rating of an arrester is the power frequency line-to-earth voltage U_r at which the arrester is designed to pass the IEC 99-4 operating duty test. Table 2 provides a general guide for the selection of the proper arrester for a given system voltage. Eaton's application engineers are available to make specific system application recommendations.

Selection of arrester rating

In arrester rating selection it is preferable to determine the lowest arrester rating that will ensure satisfactory operation. This is the optimum solution because the arrester selected will not only provide the greatest margin of insulation protection but also be the most economical choice.

Increasing arrester rating above the minimum increases the likelihood of arrester survival during potential system

contingencies but compromises the protection of equipment insulation. Table 2 lists VariSTAR AZG3 Arrester Ratings commonly used on various 3-phase systems.

Rating selection should begin with consideration of the maximum system operating voltage. The maximum power frequency voltage expected under normal system conditions (expressed line-to-earth) should not exceed the selected arrester's continuous operating voltage (U_c).

The temporary overvoltage (TOV) capability of the VariSTAR AZG3 Arrester is shown in Figure 3. The curves indicate the arrester's ability to withstand abnormal system power frequency (sinusoidal) overvoltages for various durations. The values shown assume that the arrester has been energized at COV (U_c) prior to an overvoltage event and that the arrester is in an ambient temperature of 60 degrees celsius. After the overvoltage durations shown, the arrester will thermally recover when once again energized at COV (U_c).

It is not recommended that the TOV curve be extended for periods in excess of 10,000 seconds (2.8 hrs). For ungrounded systems, systems utilizing high impedance or resonant grounding and other systems where the line-to-earth voltage may be elevated to line-to-line voltages for extended periods, arresters having a COV (U_c) equal to line-to-line voltage may be required.

For non-sinusoidal transient voltages caused by system switching operations, a transient network analyzer (TNA) study is recommended; Eaton's engineers are available to make these studies.

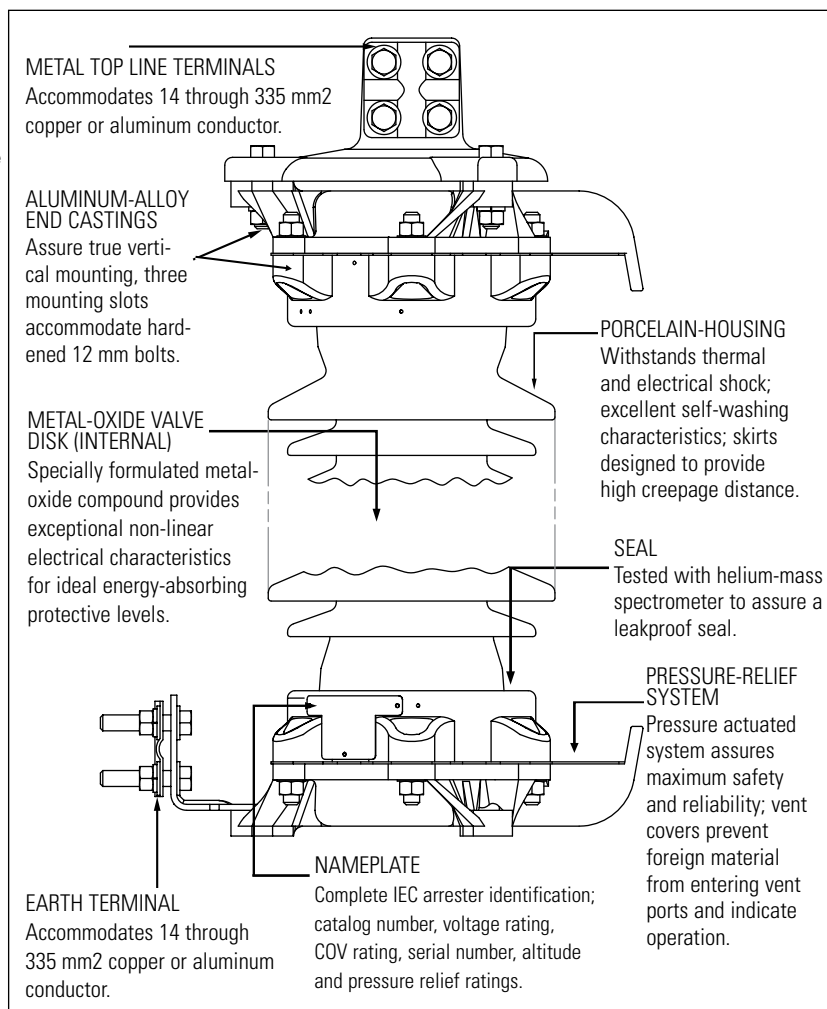

Figure 3 also illustrates the arrester's TOV capabilities with and without prior switching surge duties of up to a maximum capability of 5.6 kJ/kV of COV (U_C).

To assure proper application, the following information is normally required:

1. Maximum system operating voltage.
2. System grounding conditions.
 - A. For four-wire circuits, grounding conditions depend upon whether the system is multi-grounded, whether it has neutral impedance, and whether common primary and secondary neutrals are used.
 - B. For three-wire circuits, grounding conditions depend upon whether the system is solidly grounded at the source, grounded through neutral impedance at the source, grounded through transformers, or ungrounded.

Where unusual conditions exist (high ground resistance, high capacitive load, unusual switching surge duty, etc.), the following supplementary information is required:

1. Type of unusual condition.
2. BIL of equipment and separation distance to protected equipment.
3. Type of construction (phase spacing, length of line, conductor size, etc.).
4. Grounding and phase-sequence components of source impedances.
5. Phase-sequence components of load impedances.
6. Available fault current.
7. Potential for loss of neutral earthing during system events.

Table 2. Arrester Ratings Commonly Used on 3-Phase Systems

System Voltages L-L (kV)		Arrester Ratings (kV)	
Nominal	Max	Grounded Circuits	High-Impedance/ Ungrounded Circuits
3.3	3.7	3	—
6.6	7.3	6	9
10.0	11.5	9	12-15
11.0	12.0	9-10	12-15
16.4	18.0	15	18-21
22.0	24.0	18-21	24-27
33.0	36.3	27-30	36-39
47.0	52.0	39-48	54-60
66.0	72.0	54-60	66-84
91.0	100	78-84	90-96
110	123	96-108	120-138
132	145	108-120	132-144
155	170	132-144	162-172
220	245	180-198	204-240
275	300	216-240	258-294
345	362	258-288	294-312

Performance and protective characteristics

Table 4, "Residual Voltages – Maximum Guaranteed Protective Characteristics For Type AZG3 Surge Arresters" displays the Arrester Rating (U_p), Continuous Operating Voltage (U_C) and the guaranteed protective characteristics.

The Steep Current Impulse protective level is the maximum residual voltage for an impulse current of specified magnitude rising to crest in one microsecond. Lightning Impulse Residual Voltages represent the maximum protective levels exhibited by the arrester when discharging lightning currents of the standard 8/20 microsecond waveshape. The maximum Switching Impulse Residual Voltages are based on a switching surge current having a time to crest of 30 microseconds. For all ratings the switching surge energy absorption capability is 5.6 kJ/kV of COV (U_C).

Routine tests

A complete production test program assures the quality of every VariSTAR AZG3 Surge Arrester. Each completed arrester is required to satisfactorily pass the following test regimen conducted in accordance with the procedures established in IEC 99-4:

- Partial Discharge Test at 1.05 times U_C .
- Reference Voltage Test (U_{ref}), voltage measured at Reference
- Current (I_{ref}).
- Leakage current is measured at U_C .
- Residual Voltage Test.
- Sealing Effectiveness Test of Housing by helium mass spectrometer.

Standards

The VariSTAR AZG3 Surge Arrester has been tested and certified to IEC Standard 99-4. Guaranteed performance characteristics are specified in this catalog section and in the relevant "Design Certification Test Report", CP9818.

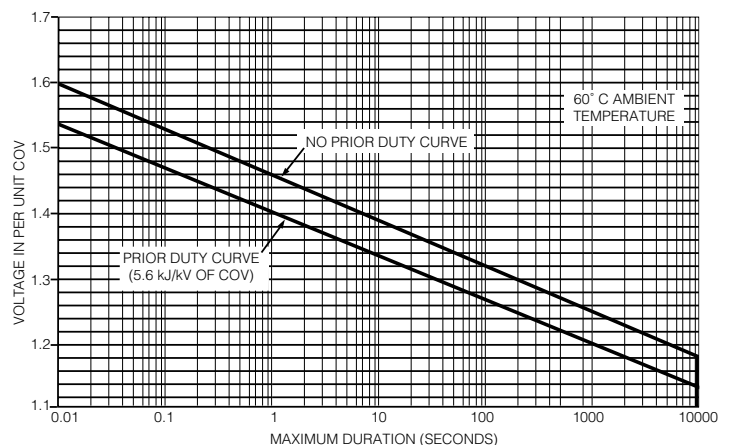

Figure 3. Temporary overvoltage capability of VariSTAR AZG3 Surge Arresters.

Table 3. Type AZG3 Surge Arrester Insulation Withstand Characteristics

Housing Designation*	Leakage Distance (mm)	Arc Distance (mm)	BIL - kV Pk 1.2/50 Wave	50/60 Hz Wet (60s)- kV rms	Switching-Wet (kV Pk)
01	234	132	130	35	**
02	406	195	170	60	**
03	665	291	230	90	**
04	922	386	265	125	**
05	1267	513	320	165	**
06	1646	600	365	170	**
07	1872	672	385	195	**
08	2540	889	505	250	**
09	3226	1106	650	285	**
11	3292	1199	725	345	**
12	3518	1272	735	360	**
13	3744	1344	770	395	**
14	4186	4189	865	415	**
15	4412	1561	880	450	**
16	4872	1706	985	450	**
17	3292	1150	705	335	**
18	3518	1218	780	370	**
19	3744	1291	790	385	**
20	4186	1440	850	400	**
21	4412	1508	920	440	**
22	4872	1548	925	440	750
23	5098	1620	930	480	810
24	5766	1839	1065	530	915
25	6452	2055	1185	545	1015
27	6744	2099	1265	625	1065
28	6970	2171	1300	655	1100
29	7412	2316	1375	675	1150
30	7638	2389	1405	705	1190
31	8098	2533	1475	710	1250
32	8306	2606	1515	760	1280
34	8992	2750	1440	760	1235
35	9677	2967	1535	810	1315

* Housing designation is indicated in the 6th and 7th position of the catalog number.

** IEC Standard 60099-4 (99-4) 1991 does not require Wet Switching Surge Withstand tests for arresters with rated voltage (Ur) below 200 kV. Housing designations 21 and below are not used in arresters rated above 198 kV

Table 4. Residual Voltages - Maximum Guaranteed Protective Characteristics for Type AZG3 Surge

Arrester Rating Ur (kV, rms)	Arrester MCOV Uc (kV, rms)	Steep Current Residual Voltage (kV Crest) 10 kA	Lightning Impulse Residual Voltage (kV Crest) 8/20 μ s Current Wave						Switching Impulse Residual Voltage (kV Crest) 30/60 Current Wave	
			1.5 kA	3 kA	5 kA	10 kA	20 kA	40 kA	125 A	500 A
3	2.55	13.1	7.0	7.4	7.7	8.3	9.4	10.7	6.5	6.7
6	5.10	22.0	13.8	14.6	15.2	16.3	18.2	20.5	12.9	13.4
9	7.65	31.0	20.7	21.8	22.7	24.3	27.0	30.3	19.3	20.0
10	8.40	33.7	22.7	24.0	24.9	26.7	29.6	33.2	21.2	22.0
12	10.2	40.0	27.6	29.1	30.2	32.4	35.9	40.2	25.7	26.7
15	12.7	48.8	34.3	36.1	37.5	40.2	44.5	49.7	32.0	33.2
18	15.3	57.9	41.3	43.5	45.2	48.4	53.5	59.8	38.5	39.9
21	17.0	64.0	46.0	48.4	50.2	53.8	59.4	66.4	42.8	44.4
24	19.5	72.8	52.7	55.5	57.6	61.7	68.1	76.1	49.1	51.0
27	22.0	81.5	59.4	62.5	64.9	69.5	76.7	85.6	55.4	57.4
30	24.4	90.1	65.9	69.4	72.0	77.1	85.0	94.9	61.5	63.7
33	27.5	101	74.3	78.2	81.2	86.9	95.8	107	69.3	71.8
36	29.0	106	78.4	82.4	85.6	91.6	101	113	73.0	75.7
39	31.5	115	85.1	89.5	93.0	99.5	110	122	79.4	82.3
42	34.0	120	89.2	93.8	97.4	104	115	128	83.1	86.2
45	36.5	128	95.2	100	104	111	123	137	88.7	91.9
48	39	137	102	107	111	119	131	146	95.1	98.6
54	42	147	110	115	120	128	141	158	102	106
60	48	167	125	132	137	146	161	180	117	121
66	53	184	138	145	151	161	177	198	129	133
72	57	199	149	157	163	174	192	214	139	144
78	62	216	162	170	177	189	208	232	151	157
84	68	236	177	187	194	207	228	254	165	171
90	70	242	183	192	199	213	235	262	170	176
96	76	263	198	208	216	231	254	284	185	191
108	84	291	219	231	240	256	282	314	205	212
120	98	338	255	269	279	298	328	366	238	247
132	106	368	276	290	301	322	355	396	257	267
138	111	386	290	305	316	338	372	415	270	280
144	115	401	301	317	328	351	387	431	280	291
162	130	450	339	356	370	395	435	485	316	327
168	131	455	342	360	373	399	440	490	319	331
172	140	485	365	384	399	426	469	523	340	353
180	144	498	375	395	410	438	482	538	350	363
192	152	526	397	417	433	463	510	568	370	384
198	160	553	417	439	456	487	536	598	389	403
204	165	570	430	452	470	502	553	616	401	416
216	174	601	454	478	496	530	583	650	424	439
228	182	628	475	499	518	554	610	680	443	459
240	190	655	495	521	541	578	636	709	462	479
258	209	725	546	574	596	638	702	782	509	528
264	212	735	554	582	604	647	711	793	516	535
276	220	761	573	603	626	670	737	821	535	554
288	230	796	601	632	656	702	772	860	560	581
294	235	813	614	645	670	717	788	879	572	593
300	239	827	624	656	681	729	802	893	582	603
312	245	847	639	672	698	747	821	915	596	618

Dimensions and mounting

Figure 4 illustrates an in-line mounting arrangement; the applicable values of "C" and "D" may be found in Table 5. Line and earth terminal details are shown in Figure 5; the supplied terminals accommodate aluminum and copper conductors to a maximum size of 335 mm². For other conductors the terminal drilling pattern shown will accommodate industry standard two (2) and four (4) hole flat pad connectors having a 45mm spacing. Figure 6 provides the dimensional details for universal base mounting.

The vent port in the base must be directed away from any adjacent equipment to control and prevent ionized gases from damaging other equipment in the unlikely event of arrester failure.

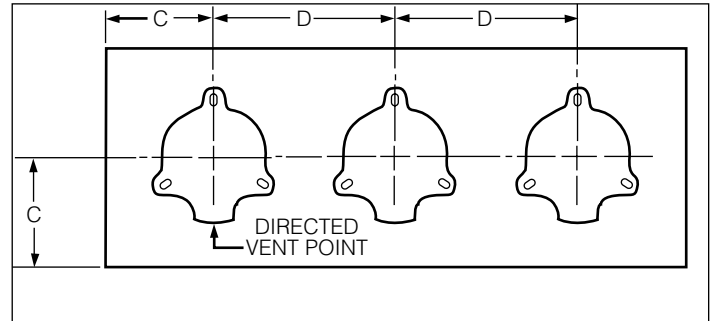

Figure 4.
 Three-phase in-line mounting.

Note: Refer to Table 5 for dimensions C and D.

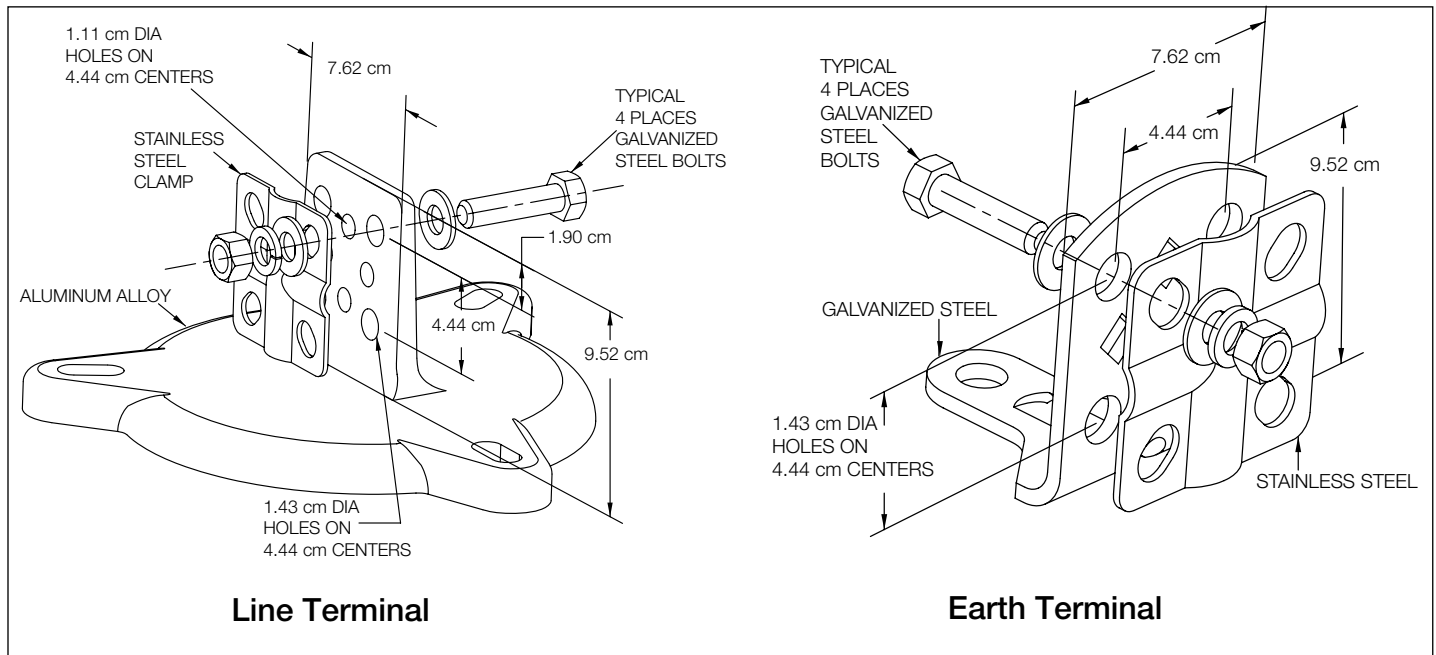

Figure 5.
 Line and earth terminals (suitable for copper or aluminum conductors up to 335 mm² (up to a maximum diameter of 20 mm)).

Table 5. Catalog Numbers and Dimensional Information (See Figures 4 & 8)

Ur Arrester Rating (kV, rms)	Uc Arrester COV (kV, rms)	Catalog Number	Dim. A (mm)	Figure 6 View Number	Dim. C Minimum Phase-to-Earth* Clearance (mm)	Dim. D Minimum Phase-to-Phase* Clearance (mm)	Housing Leakage Distance (mm)	Arrester Mass (kg)
3	2.55	AZG3001G002003	471	1	163	308	234	19
6	5.10	AZG3001G005006	471	1	166	310	234	19
9	7.65	AZG3001G007009	471	1	176	320	234	20
10	8.40	AZG3002G008010	535	1	180	324	406	22
12	10.2	AZG3002G010012	535	1	191	336	406	23
15	12.7	AZG3002G012015	535	1	211	355	406	23
18	15.3	AZG3003G015018	630	1	234	379	665	26
21	17.0	AZG3003G017021	630	1	251	395	665	27
24	19.5	AZG3003G019024	630	1	255	400	665	26
27	22.0	AZG3004G022027	725	1	278	422	922	31
30	24.4	AZG3004G024030	725	1	300	444	922	31
33	27.5	AZG3004G027033	725	1	328	473	922	31
36	29.0	AZG3004G029036	725	1	342	486	922	32
39	31.5	AZG3005G031039	852	1	365	509	1267	37
42	34.0	AZG3005G034042	852	1	378	522	1267	37
45	36.5	AZG3005G036045	852	1	398	543	1267	37
48	39.0	AZG3005G039048	852	1	421	566	1267	37
54	42.0	AZG3006G042054	929	1	447	592	1646	41
60	48.0	AZG3006G048060	929	1	499	644	1646	42
66	53.0	AZG3007G053066	1002	1	543	687	1872	46
72	57.0	AZG3007G057072	1002	1	580	725	1872	47
78	62.0	AZG3008G062078	1219	1	624	768	2540	56
84	68.0	AZG3008G068084	1219	1	676	821	2540	56
90	70.0	AZG3008G070090	1219	1	693	838	2540	57
96	76.0	AZG3008G076096	1219	1	745	890	2540	58
108	84.0	AZG3009G084108	1436	1	818	962	3226	77
120	98.0	AZG3009G098120	1436	1	940	1084	3226	79
132	106	AZG3012G106132	1816	2	1009	1154	3518	88
138	111	AZG3012G111138	1816	2	1055	1200	3518	89
144	115	AZG3013G115144	1898	2	1093	1238	3744	93
162	130	AZG3014G130162	2034	2	1220	1365	4186	100
168	131	AZG3015G131168	2106	2	1232	1377	4412	104
172	140	AZG3021G140172	2116	3	1496	1826	4412	107
180	144	AZG3022G144180	2261	3	1531	1861	4872	122
192	152	AZG3022G152192	2261	3	1603	1933	4872	123
198	160	AZG3023G160198	2333	3	1673	2003	5098	128
204	165	AZG3024G165204	2550	3	1716	2046	5766	137
216	174	AZG3024G174216	2550	3	1797	2128	5766	138
228	182	AZG3025G182228	2768	3	1867	2197	6452	157
240	190	AZG3025G190240	2768	3	1936	2266	6452	159
258	209	AZG3027G209258	3148	4	2313	2847	6744	172
264	212	AZG3027G212264	3148	4	2339	2873	6744	173
276	220	AZG3029G220276	3366	4	2406	2939	7412	182
288	230	AZG3029G230288	3366	4	2499	3032	7412	183
294	235	AZG3030G235294	3438	4	2542	3075	7638	191
300	239	AZG3030G239300	3438	4	2577	3110	7638	192
312	245	AZG3031G245312	3583	4	2629	3162	8098	207

Table 5 Notes:

1. All arresters are available in grey (standard) or brown porcelain glaze. For brown glaze substitute "B" for "G" in the eighth position of the catalog number.
 2. Cantilever strength for all ratings is 10,200 NM. Maximum working load should not exceed 40% of this value.
 3. Refer to Figure 4 for Illustration of Dimensions C and D and Figure 8 for Dimension A.
- * Phase-to-phase clearances are expressed as minimum arrester center-to-center distances. Phase-to-earth clearances are expressed as minimum arrester centerline-to-earth distances.

Figure 6. Base mounting

Note: To develop rated cantilever strength use 254 mm bolt circle mounting diameter and hardened bolts.

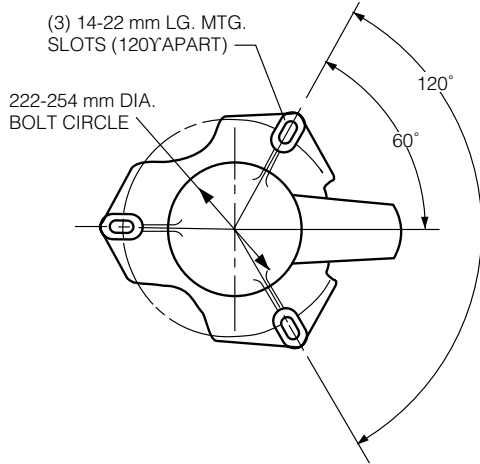

Figure 7. Arrester Nameplate.

Note: Refer to Figure 2.

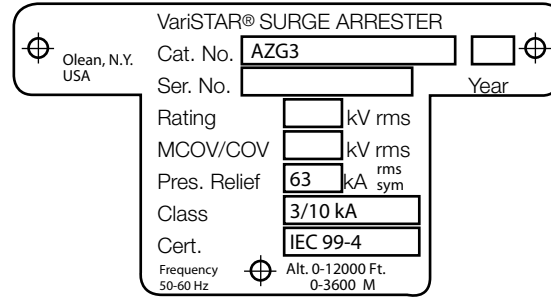
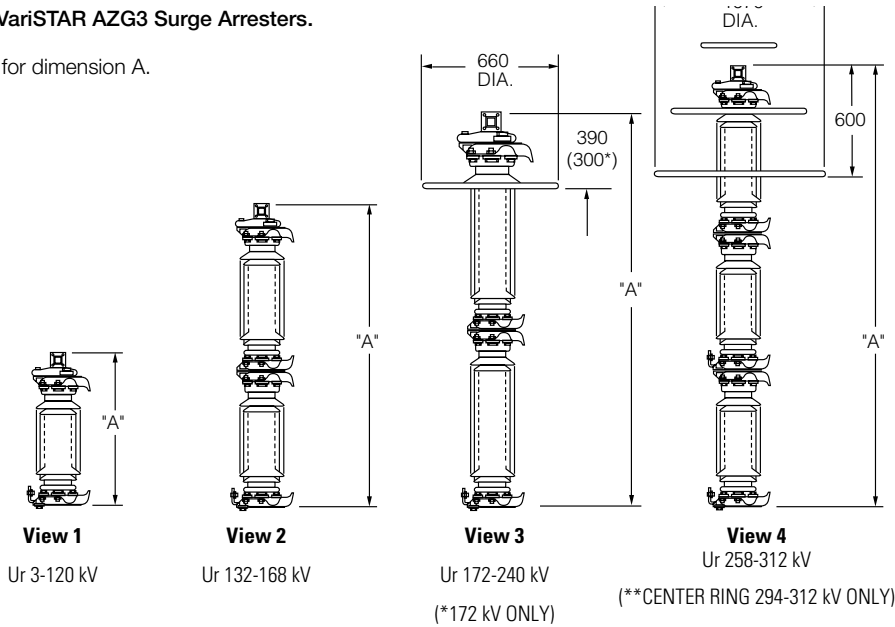

Figure 8. Outlines of VariSTAR AZG3 Surge Arresters.

Note: Refer to Table 5 for dimension A.



Eaton
1000 Eaton Boulevard
Cleveland, OH 44122
United States
Eaton.com

Eaton's Power Systems Division
2300 Badger Drive
Waukesha, WI 53188
United States
Eaton.com/cooperpowerseries

© 2016 Eaton
All Rights Reserved
Printed in USA
Publication No. CA235031EN

Eaton is a registered trademark.
All trademarks are property
of their respective owners.

For Eaton's Cooper Power series grounding
equipment product information
call 1-877-277-4636 or visit:
www.eaton.com/cooperpowerseries.