

UltraSIL™ polymer-housed VariSTAR™ UHAF and UXLG hollow-core high- strength station-class surge arresters



EATON

Powering Business Worldwide

Table of contents

General	3
Construction	3
Features	3
Operation	4
Table 1 UHAF and UXLG hollow core High-Strength arrester ratings and characteristics	4
Design testing	5
Production tests	5
General application recommendations	5
Table 2 Arrester ratings commonly used on three-phase systems	5
Temporary overvoltage (TOV) withstand ability	6
Mounting information	6
Ordering information	6
Protective characteristics - UHAF	7
Table 3 Protective characteristics of the UltraSIL™ polymer-housed UHAF arrester	7
Table 4 Creepage distances and insulation withstand voltages of UHAF high-strength station-class surge arresters	8
Spacing requirements	9
Table 5 Dimensions, clearance requirements and weights of UHAF high-strength station-class surge arresters	9
Protective characteristics - UXLG	10
Table 6 Protective characteristics of the UltraSIL™ polymer-housed UXLG arrester	10
Table 7 Creepage distances and insulation withstand voltages of UXLG high-strength station-class surge arresters	11
Spacing requirements	12
Table 8 Dimensions, clearance requirements and weights of UXLG High-strength station-class surge arresters	12
Table 9 Catalog numbers for standard configuration type UHAF and UXLG surge arresters	14
Table 10 UltraQUIK catalog numbering system for ultrasil polymer-housed high-strength station-class arresters	15
Nameplate information	17
Additional information	17

General

Eaton has set a new standard of excellence for polymer-housed hollow core station-class surge arresters. Eaton's composite hollow core design provides tremendous mechanical stability with increased cantilever strength in ratings up to 396 KV for grounded neutral circuits. Eaton's Cooper Power™ series UltraSIL™ Polymer-Housed VariSTAR™ UHAF and UXLG Hollow Core Station-Class Surge Arresters incorporate the industry recognized superior silicone rubber housing with a unique high creep alternating shed profile designed to withstand the most extreme environments. The standard silicone rubber housing is designed with a creepage distance for high pollution environments. This housing is molded over a high strength composite hollow tube which encloses the Eaton MOV disks. This unique design provides the highest quality protection with ultra-high cantilever strength and directional venting for the ultimate in substation arrester performance.

Eaton's UHAF and UXLG hollow core arresters meet or exceed the requirements of IEEE Std C62.11™-2012 standard.

Construction

The unique construction of UltraSIL polymer housed hollow core UHAF and UXLG arresters begin with Eaton world class Metal Oxide Varistor (MOV) disks produced in our dedicated manufacturing facility in Olean NY. Manufacturing our own MOV disks results in strict quality control over the entire production process, from initial raw material selection to final physical inspection and electrical testing of each disk and arrester. In addition, by controlling the manufacturing process of both disks and arresters, we achieve an optimal design and superior quality. Eaton produces MOV disks of unsurpassed quality through continuous improvements in disk formulation and manufacturing technology. The end result is a long history of in-service use with outstanding durability and protective characteristics.

The hollow core station arresters obtain their high strength and stability from a reinforced tube that is bonded to the aluminium cast end fittings and overmolded with Eaton's UltraSIL silicone rubber housing for a void free water tight bond. This produces a high dielectric strength assembly and trouble free service.

The final assembly is subject to extensive testing that meets or exceeds applicable IEEE standards.

Features

The UltraSIL silicone rubber housing material was selected for its superior insulation performance as compared to other polymeric housing materials. Long term environmental testing has verified the performance advantages that silicone rubber provides.



Independent laboratory tests have verified the superior water repelling behavior of silicone rubber, which is responsible for lower external losses when wet, higher resistance to UV degradation and surface tracking, superior performance in contaminated environments, and other important insulating properties. Also the UltraSIL silicone rubber does not support biological growth and is flame retardant.

The arrester’s aluminum line side casting provides for a NEMA 4-hold pad for connection flexibility for your application. In addition, these end-castings are designed with built in directional venting to protect your valuable substation assets in the unlikely event of an arrester failure end of life event.

Operation

The operation of the UHAF and UXLG high-strength arresters are typical of gapless metal oxide arresters. During steady-state conditions, line-to-ground voltage is applied continuously between the line and ground terminals of the arrester. When surges occur, the arrester immediately limits, or clamps, the overvoltage condition by conducting the surge current to ground. After passage of the surge, the arrester returns to its initial state, conducting minimal leakage current.

UHAF and UXLG high-strength arresters surpass the minimum fault current withstand requirement for station-class arresters as defined in IEEE Std C62.11™-2012 standard of 40kA. These arresters have been tested to withstand fault currents of 63 kA. Upon high fault current conditions the VariSTAR UHAF and UXLG arrester designs are produced with an integral pressure venting system which will rapidly relieve internal pressure and transfer the internal arc to the outside of the arrester silicone rubber housing through vent ports in the end castings.

When called upon to operate, this integral pressure relief system vents internal pressures in fractions of a cycle without expelling internal parts. In addition, the directional venting feature of these arresters allows the internal pressures to be vented away from valuable substation assets.

UHAF and UXLG high-strength arresters provide reliable protection for substation equipment, capacitor banks, multiple lines, and cable circuits. They are also provide unsurpassed lightning protection.

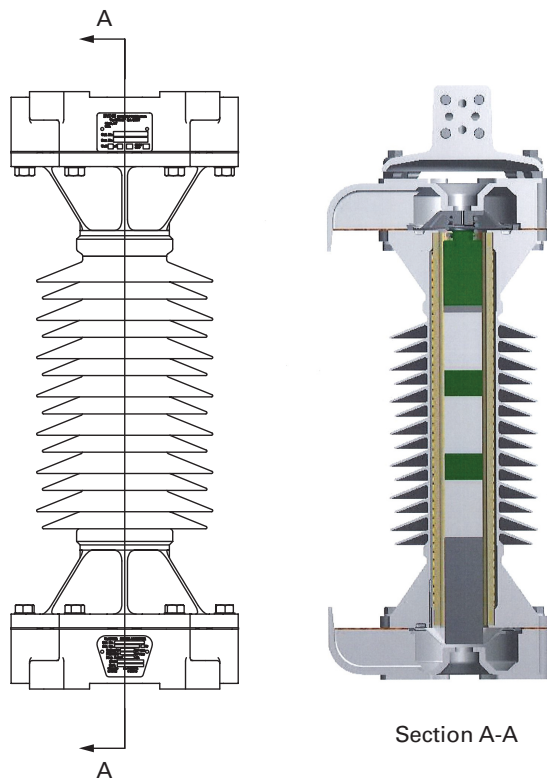

Figure 1. Illustration of 10 kV UltraSIL polymer-housed VariSTAR hollow core arrester.

Table 1. UHAF and UXLG hollow core High-Strength arrester ratings and characteristics

Arrester characteristic	Rating	
Arrester voltage ratings (kV)	3-396	
Double impulse discharge energy rating	MCOV*	
UHAF	9 kJ/kV	
UXLG	15 kJ/kV	
System frequency (Hz)	50/60	
Impulse classifying current (kA)	10	
High current withstand** (kA)	100	
Pressure relief rating (kA rms sym.)	63	
Cantilever strength (in-lbs)	Ultimate	MDCLStatic***
UHAF (3-288 kV)	120,000	48,000
UXLG (3-396 kV)	180,000	72,000

* UHAF meets class E and UXLG meets class H energy levels per IEEE Std C62.11™-2012 standard

** High current, short duration withstand (100 kA, 4/10 μs)

*** Maximum design cantilever load — static or maximum working load is 40% of the ultimate.

Design testing

The housing, internal components, and hardware of an arrester must work together as a system. This system must provide years of service while being subjected to a wide range of environmental and electrical stresses. To ensure a superior level of performance, both arrester components and finished arresters have been subjected to a series of tests that accurately represents years of exposure to actual field conditions. This testing exceeds the requirements of industry standards. UHAF and UXLG hollow core arresters have also met or exceeded all requirements for station-class arresters as defined by IEEE Std C62.11™-2012 standard.

Production tests

Eaton has implemented a complete production test program to ensure a quality product. All tests are conducted in accordance with IEEE Std C62.11™- 2012 standard. Each MOV disk is subjected to a series of electrical tests to maintain quality. We also perform additional tests on every MOV disk batch. Listed below are the tests performed on the MOV disks:

- 100% Physical inspection
- 100% Discharge voltage test
- 100% Vref at Iref
- 100% Watts loss measured at 1.05 MCOV
- 100% Transmission line discharge energy test
- Batch High-current, short-duration test
- Batch thermal stability test
- Batch aging test

Each fully assembled UHAF and UXLG arrester must also pass the following production tests:

- 100% Physical inspection
- 100% Vref test
- 100% Watts loss test
- 100% Partial discharge test
- 100% Sealing effectiveness test of housing by helium mass spectrometer.

General application recommendations

The rating of an arrester is the maximum power-frequency line to-ground voltage at which the arrester is designed to pass an operating duty-cycle test (as defined in IEEE Std C62.11™-2012 standard). Table 2 provides a general application guide for the selection of the proper arrester rating for a given system voltage and grounding configurations as outlined in IEEE Std C62.22™-2009 standard, which is the application guide for metal oxide surge arresters.

Under fault conditions and other system anomalies, higher than normal voltages can be imposed upon an arrester. If an improper arrester is selected, these abnormal system voltages can cause arrester damage. To help ensure that the proper arrester is selected, Eaton application engineers are available to make recommendations.

Table 2. Arrester ratings commonly used on three-phase systems

System voltages L-L (kV)		Arrester ratings (kV)	
Nominal	Max	Grounded* circuits	High-Impedance/ Ungrounded Circuits
3.3	3.7	3	-
6.6	7.3	6	9
10.0	11.5	9	12-15
11.0	12.0	9-10	12-15
16.4	18.0	15	18-21
22.0	24.0	24.0	24-27
33.0	36.3	27-30	36-39
47.0	52.0	39-48	54-60
66.0	72.0	54-60	66-84
91.0	100	78-84	90-96
110	123	96-108	120-138
132	145	108-120	132-144
155	170	132-144	162-172
220	245	180-198	204-240
275	300	216-240	258-294
330	362	258-288	294-360
400	420	312-360	-
500	550	396	-

* Grounded neutral circuits

The following information is normally required:

1. Maximum system operating voltage.
2. System grounding conditions;
 - A. For four-wire circuits, grounding conditions depend upon whether the system is multi-grounded, whether it has a neutral impedance and whether common primary and secondary neutrals are used.
 - B. For three-wire circuits, grounding conditions depend upon whether the system is solidly grounded at the source, grounded through neutral impedance at the source transformers or ungrounded.
3. Available Fault Current.
4. Maximum line-to-ground voltage and overvoltage duration during fault conditions.

Contact your Eaton representative to have your individual system application needs reviewed.

Temporary overvoltage (TOV) withstand ability

The UHAF and UXLG high strength hollow core arrester's ability to withstand 60 Hz overvoltage conditions (TOV) are shown in Figures 2 & 2A. These graphs illustrate the time an arrester can survive a voltage, and recover, without going into thermal runaway, for a given voltage magnitude (expressed in Per Unit of arrester MCOV).

The graphs in Figures 2 & 2A illustrate the TOV withstand ability, with and without prior duty. The prior duty curve is based upon absorption of rated energy (Refer to Table 1 – Double impulse rating) immediately preceding application of the overvoltage.

UltraSIL VariSTAR Station Arrester TOV Curve

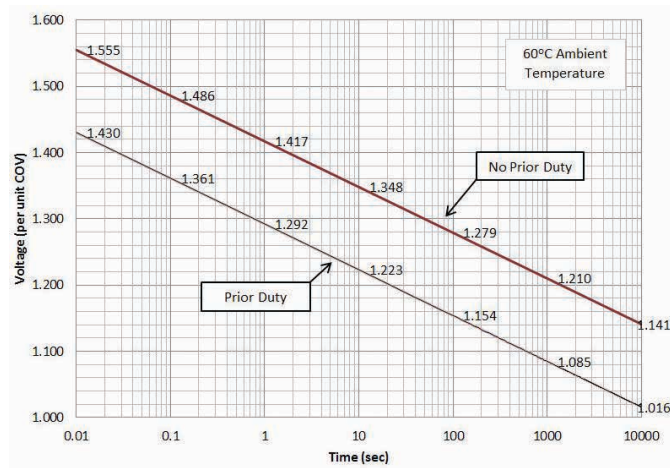

Figure 2. UHAF Temporary overvoltage curve - 60° ambient temperature

UltraSIL VariSTAR Station Arrester TOV Curve

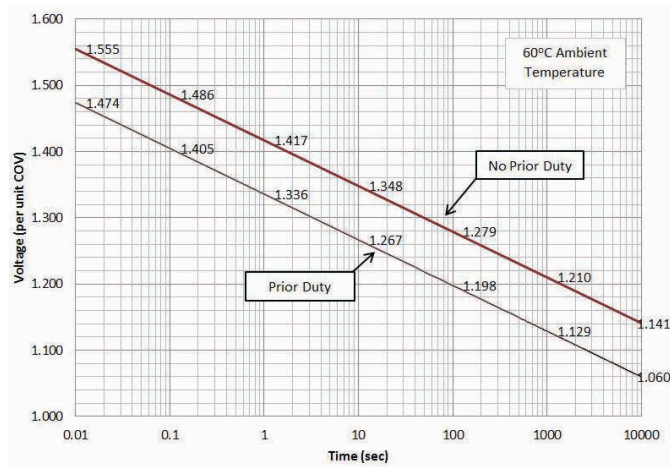

Figure 2A. UXLG Temporary overvoltage curve - 60° ambient temperature.

Mounting information

The standard base of the UHAF and UXLG hollow core arresters is shown in figure 3 mounting base details. Mounting hardware (bolts, nuts, and washers) are not included with the arrester. Contact your Eaton representative to have your individual system application needs reviewed.

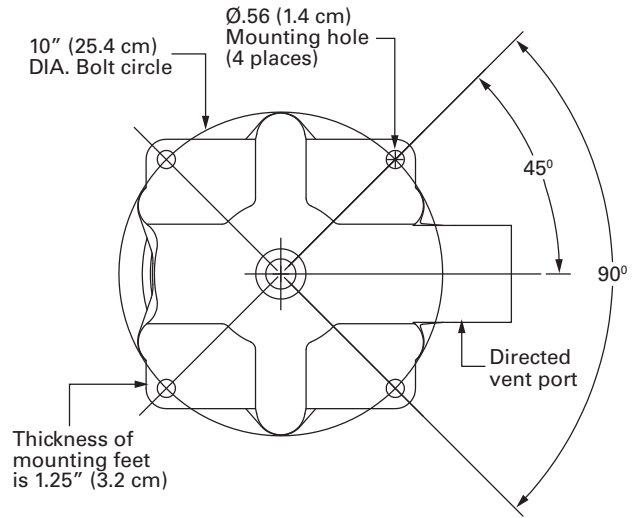

Figure 3. Mounting base details.

Ordering information

Refer to Table 10 for the UltraQUIK catalog numbering system. For additional assistance please contact your Eaton representative.

Protective characteristics - UHAF

All UltraSIL polymer-housed UHAF high-strength arresters provide excellent overvoltage protection for electrical equipment. The specific protective characteristics are shown in Table 3 below.

Table 3. Protective characteristics of the UltraSIL™ polymer-housed UHAF arrester

Arrester rating (kV, rms)	Arrester MCOV (kV rms)	TOV		Front-of-wave protective level (kV Crest)	Maximum discharge voltage (kV Crest) 8/20 μs Current wave						Switching surge protective level (kV Crest)			
		1 Sec	10 Sec		1.5 kA	3 kA	5 kA	10 kA	20 kA	40 kA	125 A	250 A	500 A	1000 A
3	2.55	3.3	3.1	8.2	6.5	6.9	7.2	7.8	8.4	9.4	5.7	5.9	6.1	6.3
6	5.1	6.6	6.2	16.3	13.0	13.7	14.3	15.6	16.8	18.8	11.4	11.7	12.1	12.6
9	7.65	9.9	9.4	24.5	19.5	20.6	21.5	23.3	25.2	28.2	17.1	17.6	18.1	18.8
10	8.4	10.9	10.3	26.9	21.4	22.6	23.6	25.6	27.7	30.9	18.8	19.3	19.9	20.7
12	10.2	13.2	12.5	32.6	26.0	27.4	28.6	31.1	33.6	37.5	22.8	23.4	24.1	25.1
15	12.7	16.4	15.5	40.6	32.4	34.1	35.6	38.7	41.9	46.7	28.4	29.1	30.0	31.2
18	15.3	19.8	18.7	48.9	39.0	41.1	42.9	46.6	50.4	56.3	34.2	35.1	36.2	37.6
21	17	22.0	20.8	54.4	43.3	45.6	47.7	51.7	56.0	62.5	38.0	39.0	40.2	41.8
24	19.5	25.2	23.8	62.4	49.7	52.3	54.7	59.3	64.2	71.7	43.6	44.7	46.1	47.9
27	22	28.4	26.9	70.3	56.0	59.0	61.7	66.9	72.5	80.9	49.1	50.4	52.0	54.0
30	24.4	31.5	29.8	78.0	62.1	65.5	68.4	74.2	80.4	89.7	54.5	55.9	57.7	59.9
33	27.5	35.5	33.6	87.9	70.0	73.8	77.1	83.6	90.6	102	61.4	63.0	65.0	67.5
36	29	37.5	35.5	92.7	73.8	77.8	81.3	88.2	95.5	107	64.8	66.4	68.6	71.2
39	31.5	40.7	38.5	101	80.2	84.5	88.3	95.8	104	116	70.3	72.2	74.5	77.3
48	39	50.4	47.7	125	99.3	105	110	119	129	144	87.1	89.3	92.2	95.7
54	42	54.3	51.4	135	107	113	118	128	139	155	93.8	96.2	99.3	104
60	48	62.0	58.7	154	123	129	135	146	159	177	108	110	114	118
66	53	68.5	64.8	170	135	143	149	162	175	195	119	122	126	131
72	57	73.6	69.7	183	146	153	160	174	188	210	128	131	135	140
78	62	80.1	75.8	199	158	167	174	189	205	228	139	142	147	153
84	68	87.9	83.2	218	174	183	191	207	224	250	152	156	161	167
90	72	93.0	88.1	231	184	194	202	219	238	265	161	165	171	177
96	76	98.2	92.9	243	194	204	214	232	251	280	170	174	180	187
108	88	113.7	107.6	282	224	236	247	268	290	324	197	202	208	216
108	84	108.5	102.7	269	214	226	236	256	277	309	188	193	199	207
120	98	126.6	119.9	314	250	263	275	298	323	361	219	225	232	241
132	106	137.0	129.6	339	270	285	298	323	349	390	237	243	251	261
138	111	143.4	135.8	355	283	298	312	338	366	408	248	255	263	273
144	115	148.6	140.6	368	293	309	323	350	379	423	257	264	272	283
162	130	168.0	159.0	416	331	349	365	396	429	478	291	298	308	319
168	131	169.3	160.2	419	334	352	368	399	432	482	293	300	310	322
172	140	180.9	171.2	448	357	376	393	426	461	515	313	321	331	344
180	144	186.0	176.1	461	367	387	404	438	475	530	322	330	341	354
192	152	196.4	185.9	486	387	408	427	463	501	559	340	348	360	373
198	160	206.7	195.7	512	408	430	449	487	527	589	358	367	378	393
204	165	213.2	201.8	528	420	443	463	502	544	607	369	378	390	405
216	174	224.8	212.8	556	443	467	488	529	573	640	389	399	412	427
228	180	232.6	220.1	576	458	483	505	548	593	662	402	413	426	442
240	190	245.5	232.4	608	484	510	533	578	626	699	424	435	449	467
258	209	270.0	255.6	668	532	561	586	636	689	769	467	479	494	513
264	212	273.9	259.3	678	540	569	595	645	698	780	474	486	501	521
276	220	284.2	269.1	703	560	590	617	669	725	809	491	504	520	540
288	230	297.2	281.3	735	586	617	645	700	758	846	514	527	544	565

Table 4. Creepage distances and insulation withstand voltages of UHAF high-strength station-class surge arresters

Arrester rating (kV, rms)	Arrester MCOV (kV rms)	Catalog number	Creepage distance (inches)	Strike	1.2/50 Impulse (kV, crest)	60Hz, dry 60 seconds (kV, rms)	60Hz, wet 10 seconds (kV, rms)	Switch surge impulse (Kv, rms)	Weight (lbs)	Grading ring
3	2.55	UHAF003002A1445A11	67.7	15.7	221	136	124	N/A	50.1	No
6	5.1	UHAF006005A1445A11	67.7	-	221	136	124	N/A	50.4	No
9	7.65	UHAF009007A1445A11	67.7	-	221	136	124	N/A	50.8	No
10	8.4	UHAF010008A1445A11	67.7	-	221	136	124	N/A	50.8	No
12	10.2	UHAF012010A1445A11	67.7	-	221	136	124	N/A	51	No
15	12.7	UHAF015012A1445A11	67.7	-	221	136	124	N/A	51.2	No
18	15.3	UHAF018015A1445A11	67.7	-	221	136	124	N/A	51.6	No
21	17	UHAF021017A1445A11	67.7	-	221	136	124	N/A	51.6	No
24	19.5	UHAF024019A1445A11	67.7	-	221	136	124	N/A	52.1	No
27	22	UHAF027022A1445A11	67.7	-	221	136	124	N/A	52.4	No
30	24.4	UHAF030024A1445A11	67.7	-	221	136	124	N/A	52.5	No
33	27.5	UHAF033027A1445A11	67.7	-	221	136	124	N/A	52.9	No
36	29	UHAF036029A1445A11	67.7	-	221	136	124	N/A	52.9	No
39	31.5	UHAF039031A1445A11	67.7	-	221	136	124	N/A	53.4	No
48	39	UHAF048039A2445A11	114.2	23.7	342	205	174	N/A	62.7	No
54	42	UHAF054042A2445A11	114.2	-	342	205	174	N/A	62.7	No
60	48	UHAF060048A2445A11	114.2	-	342	205	174	N/A	63.6	No
66	53	UHAF066053A2445A11	114.2	-	342	205	174	N/A	63.8	No
72	57	UHAF072057A2445A11	114.2	-	342	205	174	N/A	64.3	No
78	62	UHAF078062A3645A11	170	33.8	488	290	240	N/A	74.6	No
84	68	UHAF084068A3645A11	170	-	488	290	240	N/A	75	No
90	72	UHAF090072A3645A11	170	-	488	290	240	N/A	75.5	No
96	76	UHAF096076A3645A11	170	-	488	290	240	N/A	75.9	No
108	88	UHAF108088A4845A11	225.9	43.8	635	375	305	N/A	92.2	No
108	84	UHAF108084A4845A11	225.9	-	635	375	305	N/A	91.7	No
120	98	UHAF120098A4845A11	225.9	-	635	375	305	N/A	93	No
132	106	UHAF132106A4845A11	225.9	39.2	617	344	324	N/A	94	Yes
138	111	UHAF138111A4845A11	225.9	-	617	344	324	N/A	94	Yes
144	115	UHAF144115A4845A11	225.9	-	617	344	324	N/A	94.8	Yes
162	130	UHAF162130A6045A11	284.2	53.3	833	481	423	N/A	144.3	Yes
168	131	UHAF168131A6045A11	284.2	-	833	481	423	N/A	144.3	Yes
172	140	UHAF172140A7245A11	340.1	63.3	979	566	489	N/A	154.9	Yes
180	144	UHAF180144A7245A11	340.1	-	979	566	489	N/A	155.3	Yes
192	152	UHAF192152A7245A11	340.1	-	979	566	489	N/A	156.2	Yes
198	160	UHAF198160A8445A11	395.9	73	1105	634	564	N/A	167	Yes
204	165	UHAF204165A8445A11	395.9	-	1105	634	564	N/A	167.5	Yes
216	174	UHAF216174A8445A11	395.9	-	1105	634	564	N/A	168.4	Yes
228	180	UHAF228180A8445A11	395.9	-	1105	634	564	N/A	168.8	Yes
240	190	UHAF240190A9645A11	451.8	83	1148	679	556	N/A	201.1	Yes
258	209	UHAF258209A9645A11	451.8	-	1148	679	556	N/A	202.8	Yes
264	212	UHAF264212A9645A11	451.8	-	1148	679	556	N/A	203.3	Yes
276	220	UHAF276220A9645A11	451.8	-	1148	679	556	N/A	203.8	Yes
288	230	UHAF288230A9645A11	451.8	-	1148	679	556	N/A	205.1	Yes

Spacing requirements

Figure 4 illustrates a three-phase in-line mounting arrangement. Dimensions B and C reference minimum phase-to-ground and phase-to-phase distances respectively. These dimensions are listed in Tables 5.

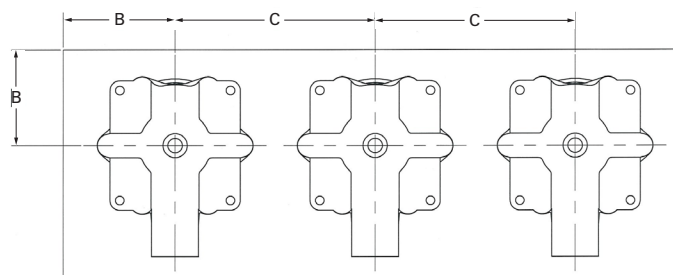

Figure 4. Three-phase In-line mounting arrangement.

Table 5. Dimensions, clearance requirements and weights of UHAF high-strength station-class surge arresters

Arrester Rating Ur (kV, rms)	Arrester MCOV (kV, rms)	Standard arrester catalog number	Dim. A (inches) (Fig. 5)	Dimension B minimum phase-to-Earth clearance (inches) (Fig. 4)	Dimension C minimum phase-to-Phase clearance (inches) (Fig. 4)	Housing diameter (inches)	Arrester weight (lbs)
3	2.55	UHAF003002A1445A11	26.1	6.5	12.0	7.7	50.1
6	5.1	UHAF006005A1445A11	26.1	6.5	12.0	7.7	50.4
9	7.65	UHAF009007A1445A11	26.1	6.6	12.1	7.7	50.8
10	8.4	UHAF010008A1445A11	26.1	6.8	12.3	7.7	50.8
12	10.2	UHAF012010A1445A11	26.1	7.2	12.7	7.7	51.0
15	12.7	UHAF015012A1445A11	26.1	7.9	13.4	7.7	51.2
18	15.3	UHAF018015A1445A11	26.1	8.8	14.3	7.7	51.6
21	17	UHAF021017A1445A11	26.1	9.4	14.9	7.7	51.6
24	19.5	UHAF024019A1445A11	26.1	9.5	15.0	7.7	52.1
27	22	UHAF027022A1445A11	26.1	10.4	15.9	7.7	52.4
30	24.4	UHAF030024A1445A11	26.1	11.2	16.7	7.7	52.5
33	27.5	UHAF033027A1445A11	26.1	12.3	17.8	7.7	52.9
36	29	UHAF036029A1445A11	26.1	12.8	18.3	7.7	52.9
39	31.5	UHAF039031A1445A11	26.1	13.7	19.2	7.7	53.4
48	39	UHAF048039A2445A11	34.5	16.3	21.8	7.7	62.7
54	42	UHAF054042A2445A11	34.5	17.3	22.8	7.7	62.7
60	48	UHAF060048A2445A11	34.5	19.4	24.9	7.7	63.6
66	53	UHAF066053A2445A11	34.5	21.1	26.6	7.7	63.8
72	57	UHAF072057A2445A11	34.5	22.5	28.0	7.7	64.3
78	62	UHAF078062A3645A11	44.6	24.2	29.7	7.7	74.6
84	68	UHAF084068A3645A11	44.6	26.3	31.8	7.7	75.0
90	72	UHAF090072A3645A11	44.6	27.6	33.1	7.7	75.5
96	76	UHAF096076A3645A11	44.6	29.0	34.5	7.7	75.9
108	88	UHAF108088A4845A11	54.6	33.2	38.7	7.7	92.2
108	84	UHAF108084A4845A11	54.6	31.8	37.3	7.7	91.7
120	98	UHAF120098A4845A11	54.6	36.6	42.1	7.7	93.0
132	106	UHAF132106A4845A11	54.6	46.9	59.9	7.7	94.0
138	111	UHAF138111A4845A11	54.6	48.6	61.6	7.7	94.0
144	115	UHAF144115A4845A11	54.6	50.0	63.0	7.7	94.8
162	130	UHAF162130A6045A11	79.1	55.2	68.2	7.7	144.3
168	131	UHAF168131A6045A11	79.1	55.5	68.5	7.7	144.3
172	140	UHAF172140A7245A11	89.1	58.6	71.6	7.7	154.9
180	144	UHAF180144A7245A11	89.1	60.0	73.0	7.7	155.3
192	152	UHAF192152A7245A11	89.1	62.7	75.7	7.7	156.2
198	160	UHAF198160A8445A11	99.2	65.5	78.5	7.7	167.0
204	165	UHAF204165A8445A11	99.2	67.2	80.2	7.7	167.5
216	174	UHAF216174A8445A11	99.2	70.3	83.3	7.7	168.4
228	180	UHAF228180A8445A11	99.2	72.4	85.4	7.7	168.8
240	190	UHAF240190A9645A11	109.0	83.8	105.0	7.7	201.1
258	209	UHAF258209A9645A11	109.0	90.4	111.0	7.7	202.8
264	212	UHAF264212A9645A11	109.0	91.4	112.0	7.7	203.3
276	220	UHAF276220A9645A11	109.0	94.2	115.0	7.7	203.8
288	230	UHAF288230A9645A11	109.0	97.6	119.0	7.7	205.1

Protective characteristics - UXLG

All UltraSIL polymer-housed UXLG high-strength arresters provide excellent overvoltage protection for electrical equipment. The specific protective characteristics are shown in Table 6 below.

Table 6. Protective characteristics of the UltraSIL™ polymer-housed UXLG arrester

Arrester rating (kV, rms)	Arrester MCOV (kV rms)	TOV		Front-of-wave protective level (kV Crest)	Maximum discharge voltage (kV Crest) 8/20 μs						Switching surge protective level (kV Crest)			
		1 Sec	10 Sec		Current wave						125 A	250 A	500 A	1000 A
					1.5 kA	3 kA	5 kA	10 kA	20 kA	40 kA				
3	2.55	3.4	3.2	7.7	6.2	6.5	6.8	7.3	7.8	8.6	5.5	5.7	5.8	6.0
6	5.1	6.8	6.5	15.3	12.5	13.0	13.5	14.6	15.6	17.2	11.0	11.3	11.6	12.0
9	7.65	10.2	9.7	22.5	18.4	19.2	20.0	21.5	23.0	25.3	16.2	16.6	17.1	17.7
10	8.4	11.2	10.6	24.7	20.2	21.1	21.9	23.6	25.2	27.8	17.8	18.3	18.8	19.5
12	10.2	13.6	12.9	30.0	24.5	25.6	26.6	28.7	30.6	33.8	21.7	22.2	22.8	23.6
15	12.7	17.0	16.1	37.3	30.4	31.9	33.1	35.7	38.1	42.0	27.0	27.6	28.4	29.4
18	15.3	20.4	19.4	45.0	36.7	38.4	39.9	43.0	45.9	50.6	32.4	33.2	34.2	35.4
21	17	22.7	21.5	50.0	40.7	42.6	44.3	47.7	51.0	56.2	36.0	36.9	38.0	39.3
24	19.5	26.1	24.7	57.3	46.7	48.9	50.8	54.8	58.5	64.5	41.3	42.3	43.6	45.1
27	22	29.4	27.9	64.7	52.7	55.2	57.3	61.8	66.0	72.7	46.6	47.8	49.2	50.9
30	24.4	32.6	30.9	71.7	58.4	61.2	63.6	68.5	73.2	80.7	51.7	53.0	54.5	56.4
33	27.5	36.7	34.8	80.8	65.8	68.9	71.6	77.2	82.5	90.9	58.3	59.7	61.4	63.6
36	29	38.7	36.7	85.2	69.4	72.7	75.5	81.4	87.0	95.9	61.5	62.9	64.8	67.1
39	31.5	42.1	39.9	92.6	75.4	79.0	82.0	88.4	94.5	105	66.8	68.4	70.4	72.9
48	39	52.1	49.4	115	93.4	97.7	102	110	117	129	82.6	84.6	87.1	90.2
54	42	56.1	53.2	124	101	106	110	118	126	139	89	91.1	93.8	97.1
60	48	64.1	60.8	141	115	121	125	135	144	159	102	105	108	111
66	53	70.8	67.2	156	127	133	138	149	159	176	113	115	119	123
72	57	76.2	72.2	168	137	143	149	160	171	189	121	124	128	132
78	62	82.8	78.6	183	149	156	162	174	186	205	132	135	139	144
84	68	90.8	86.2	200	163	171	178	191	204	225	145	148	152	158
90	72	96.2	91.2	212	173	181	188	202	216	238	153	157	161	167
96	76	101.5	96.3	224	182	191	198	214	228	252	161	165	170	176
108	88	117.6	111.5	259	211	221	230	247	264	291	187	191	197	204
108	84	112.2	106.4	247	201	211	219	236	252	278	178	183	188	195
120	98	130.9	124.2	288	235	246	256	275	294	324	208	213	219	227
132	106	141.6	134.3	312	254	266	276	298	318	351	225	230	237	246
138	111	148.3	140.6	326	266	279	289	312	333	367	236	241	248	257
144	115	153.6	145.7	338	276	289	300	323	345	380	244	250	257	266
162	130	173.7	164.7	382	312	326	339	365	390	430	276	282	291	301
168	131	175.0	166.0	385	314	329	342	368	393	433	278	285	293	303
172	140	187.0	177.4	412	335	351	365	393	420	463	297	304	313	324
180	144	192.4	182.4	423	345	361	375	404	432	476	305	313	322	333
192	152	203.1	192.6	447	364	381	396	427	456	503	322	330	340	352
198	160	213.8	202.7	470	383	401	417	449	480	529	339	347	358	370
204	165	220.4	209.1	485	395	414	430	463	495	546	350	358	369	382
216	174	232.5	220.5	512	417	436	453	489	522	575	369	378	389	403
228	180	240.5	228.1	529	431	451	469	505	540	595	382	391	402	417
240	190	253.8	240.7	558	455	476	495	533	570	628	403	412	425	440
258	209	279.2	264.8	614	501	524	545	587	627	691	443	454	467	484
264	212	283.2	268.6	623	508	532	552	595	636	701	449	460	474	490
276	220	293.9	278.7	647	527	552	573	618	660	727	466	478	492	509
288	230	307.3	291.4	676	551	577	599	646	690	760	488	499	514	532
312	245	327.3	310.4	720	587	614	638	688	735	810	519	532	548	567
330	267	356.7	338.3	785	639	669	696	749	801	883	566	579	597	618
336	272	363.4	344.6	799	651	682	709	763	816	899	577	590	608	629
360	289	386.1	366.2	849	692	724	753	811	867	955	613	627	646	668
378	306	408.8	387.7	899	733	767	797	859	918	1012	649	664	684	708
396	318	424.8	402.9	934	761	797	828	892	954	1051	674	690	711	736

Table 7. Creepage distances and insulation withstand voltages of UXLG high-strength station-class surge arresters

Arrester Rating (kV, rms)	Arrester MCOV (kV rms)	Catalog number	Creepage distance (inches)	Strike	1.2/50 Impulse (kV, crest)	60Hz, dry 60 seconds (kV, rms)	60Hz, wet 10 seconds (kV, rms)	Weight(lbs)	Grading ring
3	2.55	UXLG003002A1445A11	68.1	15.7	221	136	124	65.2	No
6	5.1	UXLG006005A1445A11	68.1	-	221	136	124	65.8	No
9	7.65	UXLG009007A1445A11	68.1	-	221	136	124	66.6	No
10	8.4	UXLG010008A1445A11	68.1	-	221	136	124	66.6	No
12	10.2	UXLG012010A1445A11	68.1	-	221	136	124	67.2	No
15	12.7	UXLG015012A1445A11	68.1	-	221	136	124	67.6	No
18	15.3	UXLG018015A1445A11	68.1	-	221	136	124	68.6	No
21	17	UXLG021017A1445A11	68.1	-	221	136	124	68.6	No
24	19.5	UXLG024019A1445A11	68.1	-	221	136	124	69.6	No
27	22	UXLG027022A1445A11	68.1	-	221	136	124	70.3	No
30	24.4	UXLG030024A1445A11	68.1	-	221	136	124	70.6	No
33	27.5	UXLG033027A1445A11	68.1	-	221	136	124	71.6	No
36	29	UXLG036029A1445A11	68.1	-	221	136	124	71.6	No
39	31.5	UXLG039031A1445A11	68.1	-	221	136	124	72.7	No
48	39	UXLG048039A2445A11	114.7	23.7	342	205	174	87.9	No
54	42	UXLG054042A2445A11	114.7	-	342	205	174	87.9	No
60	48	UXLG060048A2445A11	114.7	-	342	205	174	90	No
66	53	UXLG066053A2445A11	114.7	-	342	205	174	90.5	No
72	57	UXLG072057A2445A11	114.7	-	342	205	174	91.6	No
78	62	UXLG078062A3645A11	170.5	33.8	488	290	240	107.7	No
84	68	UXLG084068A3645A11	170.5	-	488	290	240	108.7	No
90	72	UXLG090072A3645A11	170.5	-	488	290	240	109.7	No
96	76	UXLG096076A3645A11	170.5	-	488	290	240	110.7	No
108	88	UXLG108088A4845A11	226.4	43.8	635	375	305	134.2	No
108	84	UXLG108084A4845A11	226.4	-	635	375	305	133.2	No
120	98	UXLG120098A4845A11	226.4	-	635	375	305	136.2	No
132	106	UXLG132106A4845A11	226.4	39.2	617	344	324	138.3	Yes
138	111	UXLG138111A4845A11	226.4	-	617	344	324	138.3	Yes
144	115	UXLG144115A4845A11	226.4	-	617	344	324	140.3	Yes
162	130	UXLG162130A6045A11	285.2	53.3	833	481	423	206	Yes
168	131	UXLG168131A6045A11	285.2	-	833	481	423	206	Yes
172	140	UXLG172140A7245A11	341	63.3	979	566	489	222.8	Yes
180	144	UXLG180144A7245A11	341	-	979	566	489	223.7	Yes
192	152	UXLG192152A7245A11	341	-	979	566	489	225.8	Yes
198	160	UXLG198160A8445A11	396.9	73	1105	634	564	243.3	Yes
204	165	UXLG204165A8445A11	396.9	-	1105	634	564	244.3	Yes
216	174	UXLG216174A8445A11	396.9	-	1105	634	564	246.4	Yes
228	180	UXLG228180A8445A11	396.9	-	1105	634	564	247.4	Yes
240	190	UXLG240190A9645A11	452.7	83	1148	679	556	286.9	Yes
258	209	UXLG258209A9645A11	452.7	-	1148	679	556	290.9	Yes
264	212	UXLG264212A9645A11	452.7	-	1148	679	556	292	Yes
276	220	UXLG276220A9645A11	452.7	-	1148	679	556	293	Yes
288	230	UXLG288230A9645A11	452.7	-	1148	679	556	296	Yes
312	245	UXLG312245AC045A11	567.4	-	1447	860	713	380.4	Yes
330	267	UXLG330267AD245A11	623.2	-	1594	945	778	400.9	Yes
336	272	UXLG336272AD245A11	623.2	-	1594	945	778	401.9	Yes
360	289	UXLG360289AE445A11	679.1	-	1741	1030	843	421.6	Yes
378	306	UXLG378306AE445A11	679.1	-	1741	1030	843	425.6	Yes
396	318	UXLG396318AE445A11	679.1	-	1741	1030	843	428.7	Yes

Spacing requirements

Figure 4 illustrates a three-phase in-line mounting arrangement. Dimensions B and C reference minimum phase-to-ground and phase-to-phase distances respectively. These dimensions are listed in Tables 8.

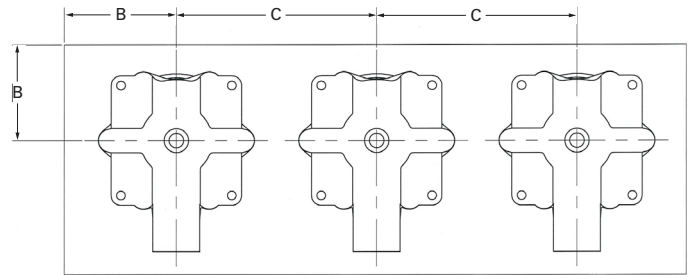

Table 8. Dimensions, clearance requirements and weights of UXLG High-strength station-class surge arresters

Arrester Rating Ur (kV, rms)	Arrester COV Uc (kV, rms)	Standard arrester catalog number	Dim. A (inches) (Fig. 5)	Dimension B minimum phase-to-Earth clearance (inches) (Fig. 4)	Dimension C minimum phase-to-Phase clearance (inches) (Fig. 4)	Dim. D (inches)	Housing leakage distance (inches)	Arrester weight (lbs)
3	2.55	UXLG003002A1445A11	26.9	6.5	12.0	8.7	68.1	65.2
6	5.1	UXLG006005A1445A11	26.9	6.5	12.0	8.7	68.1	65.8
9	7.65	UXLG009007A1445A11	26.9	6.5	12.0	8.7	68.1	66.6
10	8.4	UXLG010008A1445A11	26.9	6.6	12.1	8.7	68.1	66.6
12	10.2	UXLG012010A1445A11	26.9	7.0	12.5	8.7	68.1	67.2
15	12.7	UXLG015012A1445A11	26.9	7.5	13.0	8.7	68.1	67.6
18	15.3	UXLG018015A1445A11	26.9	8.3	13.8	8.7	68.1	68.6
21	17	UXLG021017A1445A11	26.9	8.8	14.3	8.7	68.1	68.6
24	19.5	UXLG024019A1445A11	26.9	8.9	14.4	8.7	68.1	69.6
27	22	UXLG027022A1445A11	26.9	9.6	15.1	8.7	68.1	70.3
30	24.4	UXLG030024A1445A11	26.9	10.4	15.9	8.7	68.1	70.6
33	27.5	UXLG033027A1445A11	26.9	11.3	16.8	8.7	68.1	71.6
36	29	UXLG036029A1445A11	26.9	11.8	17.3	8.7	68.1	71.6
39	31.5	UXLG039031A1445A11	26.9	12.6	18.1	8.7	68.1	72.7
48	39	UXLG048039A2445A11	35.3	14.9	20.4	8.7	114.7	87.9
54	42	UXLG054042A2445A11	35.3	15.8	21.3	8.7	114.7	87.9
60	48	UXLG060048A2445A11	35.3	17.7	23.2	8.7	114.7	90.0
66	53	UXLG066053A2445A11	35.3	19.3	24.8	8.7	114.7	90.5
72	57	UXLG072057A2445A11	35.3	20.5	26.0	8.7	114.7	91.6
78	62	UXLG078062A3645A11	45.4	22.0	27.5	8.7	170.5	107.7
84	68	UXLG084068A3645A11	45.4	23.9	29.4	8.7	170.5	108.7
90	72	UXLG090072A3645A11	45.4	25.1	30.6	8.7	170.5	109.7
96	76	UXLG096076A3645A11	45.4	26.4	31.9	8.7	170.5	110.7
108	88	UXLG108088A4845A11	55.4	30.1	35.6	8.7	226.4	134.2
108	84	UXLG108084A4845A11	55.4	28.9	34.4	8.7	226.4	133.2
120	98	UXLG120098A4845A11	55.4	33.2	38.7	8.7	226.4	136.2
132	106	UXLG132106A4845A11	55.4	43.2	56.2	8.7	226.4	138.3
138	111	UXLG138111A4845A11	55.4	44.7	57.7	8.7	226.4	138.3
144	115	UXLG144115A4845A11	55.4	46.0	59.0	8.7	226.4	140.3
162	130	UXLG162130A6045A11	80.7	50.6	63.6	8.7	285.2	206.0
168	131	UXLG168131A6045A11	80.7	50.9	63.9	8.7	285.2	206.0
172	140	UXLG172140A7245A11	90.8	53.7	66.7	8.7	341.0	222.8
180	144	UXLG180144A7245A11	90.8	55.0	68.0	8.7	341.0	223.7
192	152	UXLG192152A7245A11	90.8	57.4	70.4	8.7	341.0	225.8
198	160	UXLG198160A8445A11	101.0	59.9	72.9	8.7	396.9	243.3
204	165	UXLG204165A8445A11	101.0	61.5	74.5	8.7	396.9	244.3
216	174	UXLG216174A8445A11	101.0	64.3	77.3	8.7	396.9	246.4
228	180	UXLG228180A8445A11	101.0	66.1	79.1	8.7	396.9	247.4
240	190	UXLG240190A9645A11	111.0	77.2	98.2	8.7	452.7	286.9
258	209	UXLG258209A9645A11	111.0	83.1	104.0	8.7	452.7	290.9
264	212	UXLG264212A9645A11	111.0	84.0	105.0	8.7	452.7	292.0
276	220	UXLG276220A9645A11	111.0	86.5	108.0	8.7	452.7	293.0
288	230	UXLG288230A9645A11	111.0	89.6	111.0	8.7	452.7	296.0
312	245	UXLG312245AC045A11	146.0	101.0	128.0	8.7	567.4	380.4
330	267	UXLG330267AD245A11	156.0	108.0	135.0	8.7	623.2	400.9
336	272	UXLG336272AD245A11	156.0	109.0	137.0	8.7	623.2	401.9
360	289	UXLG360289AE445A11	166.0	114.0	142.0	8.7	679.1	421.6
378	306	UXLG378306AE445A11	166.0	120.0	147.0	8.7	679.1	425.6
396	318	UXLG396318AE445A11	166.0	123.0	151.0	8.7	679.1	428.7

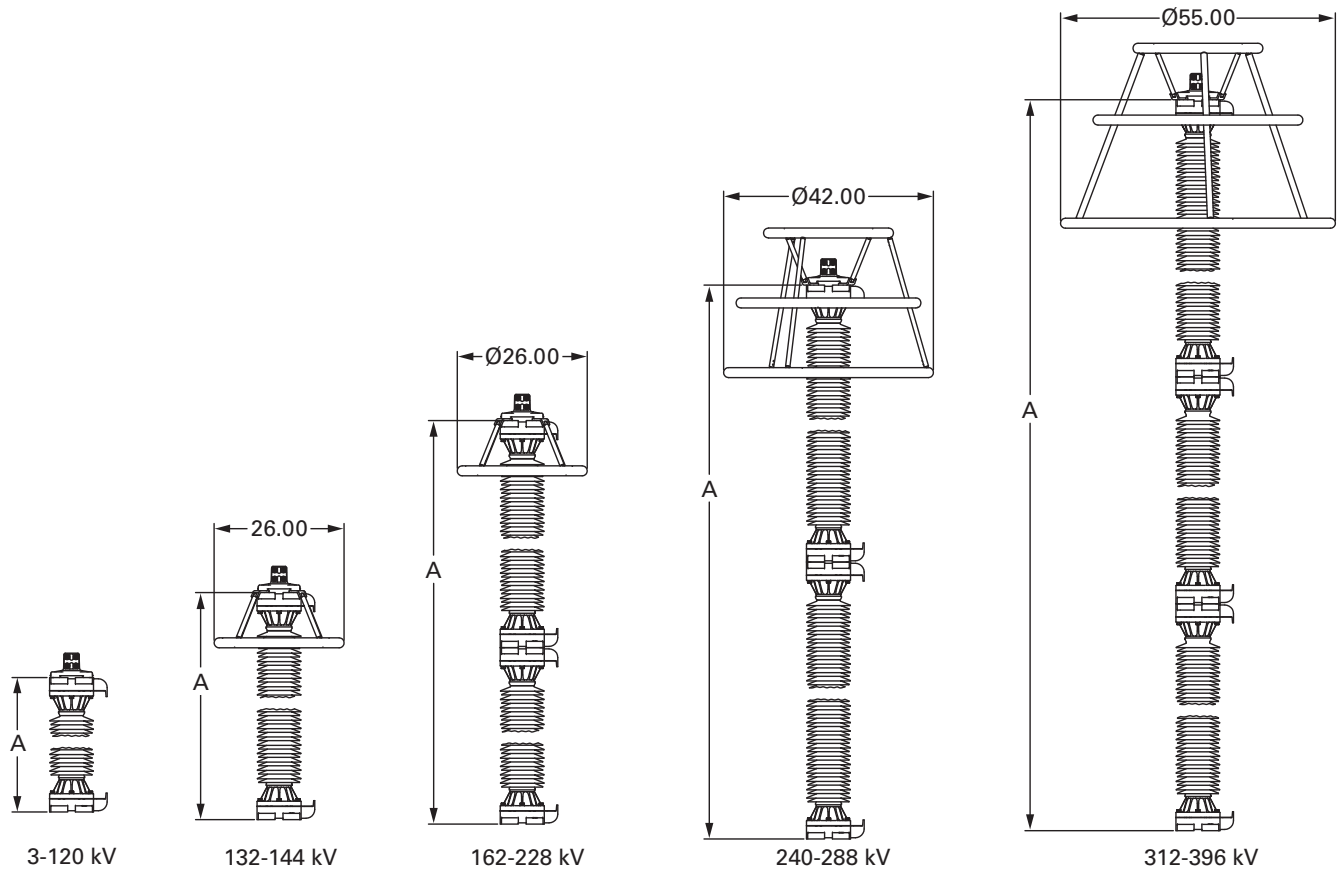

Figure 5. Outline drawing of standard ultrasil polymer-housed station-class arresters.

Note: Dimensions shown in Tables 5 and 8. Arresters are shown without line and ground terminals.

Table 9. Catalog numbers for standard configuration type UHAF and UXLG surge arresters

Arrester rating Ur (kV, rms)	Arrester COV Uc (kV, rms)	UHAF	UXLG
3	2.55	UHAF003002A1445A11	UXLG003002A1445A11
6	5.1	UHAF006005A1445A11	UXLG006005A1445A11
9	7.65	UHAF009007A1445A11	UXLG009007A1445A11
10	8.4	UHAF010008A1445A11	UXLG010008A1445A11
12	10.2	UHAF012010A1445A11	UXLG012010A1445A11
15	12.7	UHAF015012A1445A11	UXLG015012A1445A11
18	15.3	UHAF018015A1445A11	UXLG018015A1445A11
21	17	UHAF021017A1445A11	UXLG021017A1445A11
24	19.5	UHAF024019A1445A11	UXLG024019A1445A11
27	22	UHAF027022A1445A11	UXLG027022A1445A11
30	24.4	UHAF030024A1445A11	UXLG030024A1445A11
33	27.5	UHAF033027A1445A11	UXLG033027A1445A11
36	29	UHAF036029A1445A11	UXLG036029A1445A11
39	31.5	UHAF039031A1445A11	UXLG039031A1445A11
48	39	UHAF048039A2445A11	UXLG048039A2445A11
54	42	UHAF054042A2445A11	UXLG054042A2445A11
60	48	UHAF060048A2445A11	UXLG060048A2445A11
66	53	UHAF066053A2445A11	UXLG066053A2445A11
72	57	UHAF072057A2445A11	UXLG072057A2445A11
78	62	UHAF078062A3645A11	UXLG078062A3645A11
84	68	UHAF084068A3645A11	UXLG084068A3645A11
90	72	UHAF090072A3645A11	UXLG090072A3645A11
96	76	UHAF096076A3645A11	UXLG096076A3645A11
108	88	UHAF108088A4845A11	UXLG108088A4845A11
108	84	UHAF108084A4845A11	UXLG108084A4845A11
120	98	UHAF120098A4845A11	UXLG120098A4845A11
132	106	UHAF132106A4845A11	UXLG132106A4845A11
138	111	UHAF138111A4845A11	UXLG138111A4845A11
144	115	UHAF144115A4845A11	UXLG144115A4845A11
162	130	UHAF162130A6045A11	UXLG162130A6045A11
168	131	UHAF168131A6045A11	UXLG168131A6045A11
172	140	UHAF172140A7245A11	UXLG172140A7245A11
180	144	UHAF180144A7245A11	UXLG180144A7245A11
192	152	UHAF192152A7245A11	UXLG192152A7245A11
198	160	UHAF198160A8445A11	UXLG198160A8445A11
204	165	UHAF204165A8445A11	UXLG204165A8445A11
216	174	UHAF216174A8445A11	UXLG216174A8445A11
228	180	UHAF228180A8445A11	UXLG228180A8445A11
240	190	UHAF240190A9645A11	UXLG240190A9645A11
258	209	UHAF258209A9645A11	UXLG258209A9645A11
264	212	UHAF264212A9645A11	UXLG264212A9645A11
276	220	UHAF276220A9645A11	UXLG276220A9645A11
288	230	UHAF288230A9645A11	UXLG288230A9645A11
312	245	-	UXLG312245AC045A11
330	267	-	UXLG330267AD245A11
336	272	-	UXLG336272AD245A11
360	289	-	UXLG360289AE445A11
378	306	-	UXLG378306AE445A11
396	318	-	UXLG396318AE445A11

Table 10. UltraQUIK catalog numbering system for ultrasil polymer-housed high-strength station-class arresters

1	U	2	3	4	5	6	7	8	9	10	11	A	12	13	14	4	15	5	16	A	17	1	18
---	---	---	---	---	---	---	---	---	---	----	----	---	----	----	----	---	----	---	----	---	----	---	----

Catalog number digits:

- 1 = U** UltraSIL Polymer-housed arrester
- 2 = H** High energy handling
X Xtra-High energy handling
- 3 = A** Standard electrical build (9 kJ/kV of MCOV, Double Impulse)
L High electrical build (15 kJ/kV of MCOV, Double Impulse)*
- 4 = F** = 120,000 in-lbs Cantilever strength ultimate
G = 180,000 in-lbs Cantilever strength ultimate
- 5 Through 10 =** Arrester rating: Duty-cycle (MCOV)

003002 = 3 kV (2.55 kV)	048039 = 48 kV (39.0 kV)	144115 = 144 kV (115 kV)	288230 = 288 kV (230 kV)
006005 = 6 kV (5.10 kV)	054042 = 54 kV (42.0 kV)	162130 = 162 kV (130 kV)	312245 = 312 kV (245kV)*
009007 = 9 kV (7.65 kV)	060048 = 60 kV (48.0 kV)	168131 = 168 kV (131 kV)	330267 = 330 kV (267kV)*
010008 = 10 kV (8.4 kV)	066053 = 66 kV (53.0 kV)	172140 = 172 kV (140 kV)	336269 = 336 kV (269 kV)*
012010 = 12 kV (10.2 kV)	072057 = 72 kV (57.0 kV)	180144 = 180 kV (144 kV)	360289 = 360 kV (289 kV)*
015012 = 15 kV (12.7 kV)	078062 = 78 kV (62.0 kV)	192152 = 192 kV (152 kV)	378306 = 378 kV (306 kV)*
018015 = 18 kV (15.3 kV)	084068 = 84 kV (68.0 kV)	198160 = 198 kV (160 kV)	396318 = 396 kV (318 kV)*
021017 = 21 kV (17.0 kV)	090070 = 90 kV (70.0 kV)	204165 = 204 kV (165 kV)	
024019 = 24 kV (19.5 kV)	096076 = 96 kV (76.0 kV)	216174 = 216 kV (174 kV)	
027022 = 27 kV (22.0 kV)	096077 = 96 kV (77.0 kV)	228180 = 228 kV (180 kV)	
030024 = 30 kV (24.4 kV)	108084 = 108 kV (84.0 kV)	240190 = 240 kV (190 kV)	
033027 = 33 kV (27.0 kV)	120098 = 120 kV (98.0 kV)	258209 = 258 kV (209 kV)	
036029 = 36 kV (29.0 kV)	132106 = 132 kV (106 kV)	264212 = 264 kV (212 kV)	
039031 = 39 kV (31.5 kV)	138111 = 138 kV (111 kV)	276220 = 276 kV (220 kV)	

* Only available in UXLG configurations

11 = "A" Standard high creep UltraSIL Polymer-Housing

1	U	2	3	4	5	6	7	8	9	10	11	A	12	13	14	4	15	5	16	A	17	1	18
---	---	---	---	---	---	---	---	---	---	----	----	---	----	----	----	---	----	---	----	---	----	---	----

Housing codes:

Arrester rating	Digits 12 & 13	UXLG	UHAF
3 - 39 kv	14	68.1	67.7
48 - 72 kV	24	114.7	114.2
78 - 96 kV	36	170.5	170.0
108 - 144 kV	48	226.4	225.9
162 - 168 kv	60	285.2	284.2
172 - 192 kV	72	341	340.1
198 - 228 kV	84	396.9	395.9
240 - 288 kV	96	452.7	451.8
312 kV	C0	567.4	-
330 - 336 kV	D2	623.2	-
360 - 396 kV	E4	679.1	-

1	U	2	3	4	5	6	7	8	9	10	11	A	12	13	14	4	15	5	16	A	17	1	18
---	---	---	---	---	---	---	---	---	---	----	----	---	----	----	----	---	----	---	----	---	----	---	----

14: Line terminal options

Standard offering-Select 4

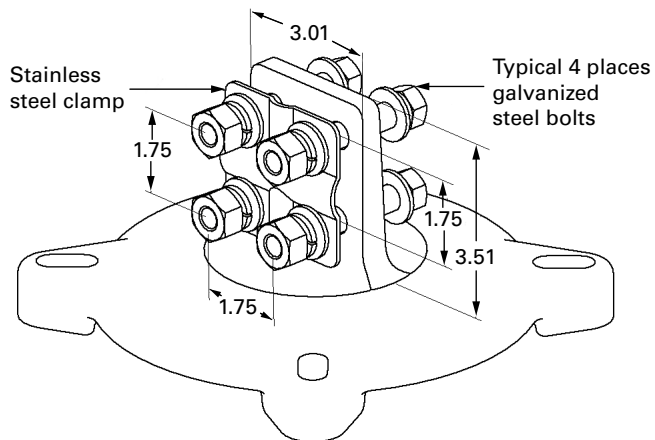

NEMA® Four-hole aluminum alloy pad and stainless terminal clamp accepts copper or aluminum conductors from .16" dia. (#6) to .78" dia. (500 MCM).

1	U	2	3	4	5	6	7	8	9	10	11	A	12	13	14	4	15	5	16	A	17	1	18
---	---	---	---	---	---	---	---	---	---	----	----	---	----	----	----	---	----	---	----	---	----	---	----

15 = Earth terminal options

Standard offering-Select 5

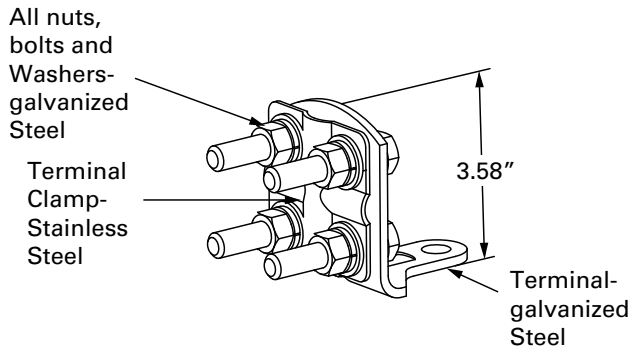

NEMA® Four-hole Pad
Accepts copper or aluminum conductors from .16" dia. (#6) to .78" dia. (500 MCM)

16 = Base mounting arrangement

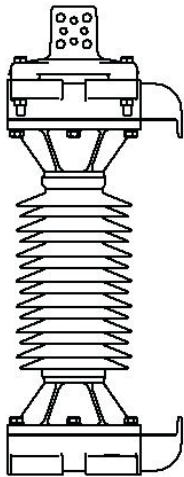

Standard offering-Select A

17 = "1" - Nameplate for standard mount per ANSI C62.11

18 = "1" - Cardboard packaging
"2" - Wood crating

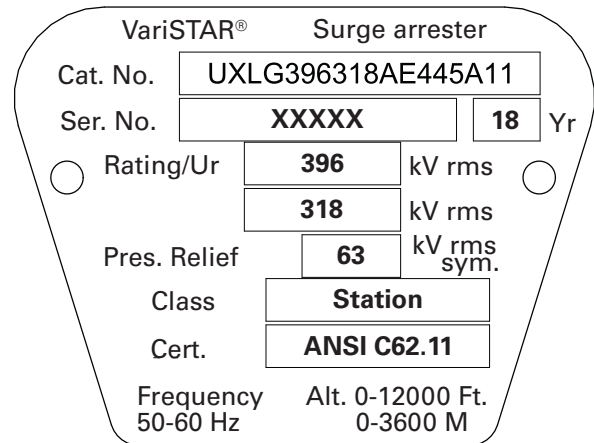

Figure 6. Detail of base nameplate.

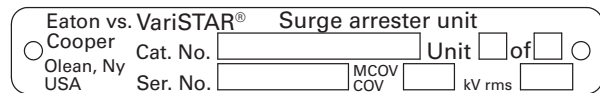

Figure 7. Detail of section nameplate.

Nameplate information

A stainless steel nameplate per Figure 6 is attached to the base of every UltraSIL polymer-housed UHAF and UXLG high-strength arrester. The arrester catalog number, serial number, year of manufacture, duty-cycle rating, MCOV rating, and pressure relief rating are among the details provided on the nameplate. For multi-unit arresters equal or higher than 162 kV, an additional unit nameplate is provided on each arrester section as shown in Figure 7.

Additional information

- MN235026EN MN235026EN UltraSIL polymer-housed VariSTAR HC hollow core station-class surge arrester installation and maintenance instructions
- CT235007EN CT235007EN UltraSIL polymer-housed VariSTAR UHAF hollow core station-class surge arrester certified test report
- CT235008EN CT235008EN UltraSIL polymer-housed VariSTAR UXLG hollow core station-class surge arrester certified test report

This page is intentionally left blank.

This page is intentionally left blank.

Eaton
1000 Eaton Boulevard
Cleveland, OH 44122
United States
Eaton.com

Eaton's Power Systems Division
2300 Badger Drive
Waukesha, WI 53188
United States
Eaton.com/cooperpowerseries

© 2019 Eaton
All Rights Reserved
Printed in USA
Publication No. CA235035EN /
CSSC-1806-5669
June 2019

Eaton is a registered trademark.

All other trademarks are property
of their respective owners.

For Eaton's Cooper Power series product
information call 1-877-277-4636 or visit:
www.eaton.com/cooperpowerseries.