

UltraSIL polymer-insulated D-73P disconnect switches installation instructions

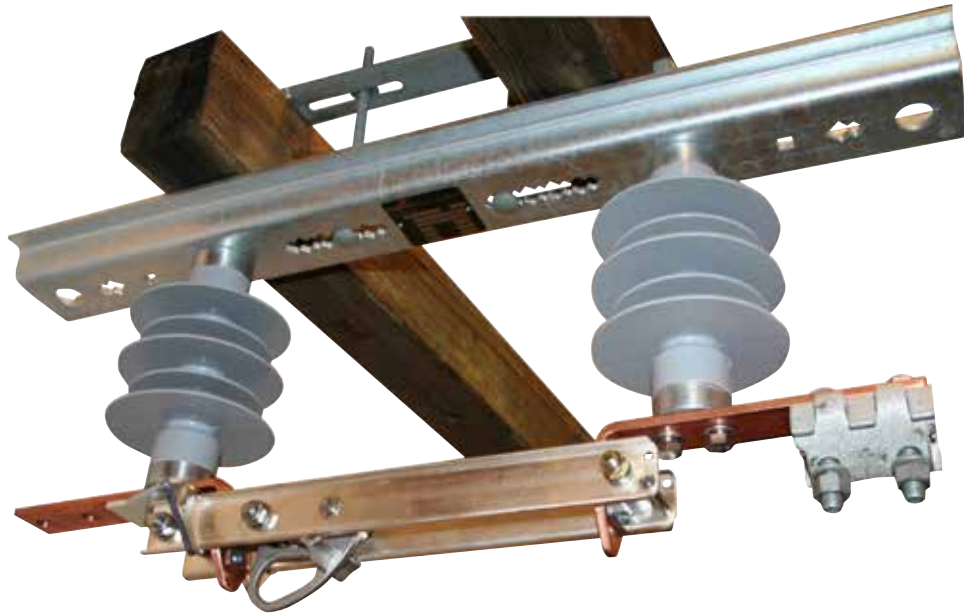

EATON

Powering Business Worldwide

DISCLAIMER OF WARRANTIES AND LIMITATION OF LIABILITY

The information, recommendations, descriptions and safety notations in this document are based on Eaton Corporation's ("Eaton") experience and judgment and may not cover all contingencies. If further information is required, an Eaton sales office should be consulted. Sale of the product shown in this literature is subject to the terms and conditions outlined in appropriate Eaton selling policies or other contractual agreement between Eaton and the purchaser.

THERE ARE NO UNDERSTANDINGS, AGREEMENTS, WARRANTIES, EXPRESSED OR IMPLIED, INCLUDING WARRANTIES OF FITNESS FOR A PARTICULAR PURPOSE OR MERCHANTABILITY, OTHER THAN THOSE SPECIFICALLY SET OUT IN ANY EXISTING CONTRACT BETWEEN THE PARTIES. ANY SUCH CONTRACT STATES THE ENTIRE OBLIGATION OF EATON. THE CONTENTS OF THIS DOCUMENT SHALL NOT BECOME PART OF OR MODIFY ANY CONTRACT BETWEEN THE PARTIES.

In no event will Eaton be responsible to the purchaser or user in contract, in tort (including negligence), strict liability or otherwise for any special, indirect, incidental or consequential damage or loss whatsoever, including but not limited to damage or loss of use of equipment, plant or power system, cost of capital, loss of power, additional expenses in the use of existing power facilities, or claims against the purchaser or user by its customers resulting from the use of the information, recommendations and descriptions contained herein. The information contained in this manual is subject to change without notice.

Contents

SAFETY INFORMATION

Safety information	iv
--------------------------	----

PRODUCT INFORMATION

Introduction	1
Acceptance and initial inspection	1
Handling and storage	1
Standards	1

D-73P INSTALLATION PROCEDURE

Mounting the switch	1
---------------------------	---

D-73P-CD INSTALLATION PROCEDURE

Mounting the switch	2
---------------------------	---

D-73P-TS INSTALLATION PROCEDURE

Mounting the switch	3
---------------------------	---

D-73P-LT INSTALLATION PROCEDURE

Mounting the switch	4
---------------------------	---

OPERATION

Operation	5
-----------------	---

MAINTENANCE

Maintenance	5
-------------------	---



Safety for life



Eaton meets or exceeds all applicable industry standards relating to product safety in its Cooper Power™ series products. We actively promote safe practices in the use and maintenance of our products through our service literature, instructional training programs, and the continuous efforts of all Eaton employees involved in product design, manufacture, marketing, and service.

We strongly urge that you always follow all locally approved safety procedures and safety instructions when working around high voltage lines and equipment, and support our “Safety For Life” mission.

Safety information

The instructions in this manual are not intended as a substitute for proper training or adequate experience in the safe operation of the equipment described. Only competent technicians who are familiar with this equipment should install, operate, and service it.

A competent technician has these qualifications:

- Is thoroughly familiar with these instructions.
- Is trained in industry-accepted high and low-voltage safe operating practices and procedures.
- Is trained and authorized to energize, de-energize, clear, and ground power distribution equipment.
- Is trained in the care and use of protective equipment such as arc flash clothing, safety glasses, face shield, hard hat, rubber gloves, clampstick, hotstick, etc.

Following is important safety information. For safe installation and operation of this equipment, be sure to read and understand all cautions and warnings.

Hazard Statement Definitions

This manual may contain four types of hazard statements:

DANGER

Indicates an imminently hazardous situation which, if not avoided, will result in death or serious injury.

WARNING

Indicates a potentially hazardous situation which, if not avoided, could result in death or serious injury.

CAUTION

Indicates a potentially hazardous situation which, if not avoided, may result in minor or moderate injury.

CAUTION

Indicates a potentially hazardous situation which, if not avoided, may result in equipment damage only.

Safety instructions

Following are general caution and warning statements that apply to this equipment. Additional statements, related to specific tasks and procedures, are located throughout the manual.

DANGER

Hazardous voltage. Contact with hazardous voltage will cause death or severe personal injury. Follow all locally approved safety procedures when working around high- and low-voltage lines and equipment.

G103.3

WARNING

Before installing, operating, maintaining, or testing this equipment, carefully read and understand the contents of this manual. Improper operation, handling or maintenance can result in death, severe personal injury, and equipment damage.

G101.0

WARNING

This equipment is not intended to protect human life. Follow all locally approved procedures and safety practices when installing or operating this equipment. Failure to comply can result in death, severe personal injury and equipment damage.

G102.1

WARNING

Power distribution and transmission equipment must be properly selected for the intended application. It must be installed and serviced by competent personnel who have been trained and understand proper safety procedures. These instructions are written for such personnel and are not a substitute for adequate training and experience in safety procedures. Failure to properly select, install or maintain power distribution and transmission equipment can result in death, severe personal injury, and equipment damage.

G122.3

Product information

Introduction

Service information MN008004EN covers installation of Eaton's Cooper Power™ series D-73P, D-73P-CD, D-73P-LT, and D-73P-TS disconnect switches.

The D-73P line of disconnect switches are single phase-operable switches to sectionalize or isolate overhead lines on electrical distribution systems up to 38 kV. It is for manual switching of de-energized parallel circuits of overhead lines on electrical distribution system. The D-73P switches have no current making or breaking ability. The switches can be mounted in wide variety of positions depending on style and mounting brackets purchased. Many terminal connections are available to customize switch to user's need.

Eaton's D-73P-CD single insulator cutout disconnect switches are hookstick operated switch designed for operation at 600 A and 900 A on overhead distribution circuits rated up to 38 kV, 150 BIL. The cutout disconnect switch is designed for riser pole application where the switch is easily installed with included cross arm bracket much like a standard cutout.

The D-73P-TS style switch is an in-line disconnect switch used to manually switch de-energized or parallel distribution circuits of 15kV through 38kV 200BIL. The D-73P-TS switches are rated at 600 and 900A continuous and may be applied directly into the line wherever line sectionalizing is desired.

The D-73P-LT single insulator line-tap disconnect switch is an in-line single-phase hookstick-operated switch designed for operation at 600 and 900A on distribution circuits up to 38kV, 150kV BIL. The switch is designed for use in feeder tap, sectionalizing, and devise isolation applications. The switch can be installed under existing line for tap applications without cutting the conductor or it can be cut into the distribution line for sectionalizing applications.

Read this manual first

Read and understand the contents of this manual and follow all locally approved procedures and safety practices before installing or operating this equipment

Additional information

These instructions cannot cover all details or variations in the equipment, procedures, or process described nor provide directions for meeting every possible contingency during installation, operation, or maintenance. When additional information is desired to satisfy a problem not covered sufficiently for the user's purpose, please contact your Eaton sales representative.

Acceptance and initial inspection

Each switch is in good condition when accepted by the carrier for shipment. Upon receipt, inspect the shipping container for signs of damage. Unpack the switch and

inspect it thoroughly for damage incurred during shipment. If damage is discovered, file a claim with the carrier immediately.

Handling and storage

Be careful during handling and storage of the switch to minimize the possibility of damage. If the switch is to be stored for any length of time prior to installation, provide a clean, dry storage area.

Standards

ISO 9001 Certified Quality Management System

D-73P installation procedure

The switch must be properly selected for each installation with consideration to continuous current, BIL, and rated voltage.

Mounting the switch

1. Eaton's D-73P line of disconnect switches come equipped with blade stop pin to provide 90 degree blade opening stop. If 90 degree blade stop is not required, remove retaining clip from one side of pin closest to hinge contact, and slide stop pin out of blade assembly.

Optional 150 degree latch (option A) available to provide positive blade stop at 150 degree opening. To utilize 150 degree latch, ensure stop pin is positioned to alternate pin hole located closest to latch side contact.

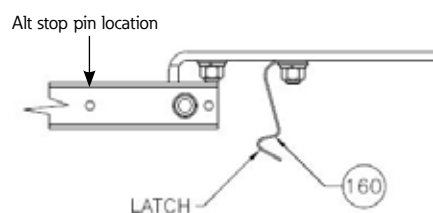

NOTE: LATCH MUST BE INSTALLED ON STUD FARTHEST FROM HINGE AND IN THE ORIENTATION SHOWN

Figure 1. 150 degree latch for D-73P, D-73P-CD, D-73P-LT style switches.

2. D-73P disconnect switch is made for mounting to either a single or double cross arm in an inverted or vertical position. Position the switch on the crossarms using the supplied backstrap.

Standard D-73P backstrap is 15" galvanized steel with two 3/8"-16 thread x 9"L carriage bolts each with nut, flat and lock washer.

Optional full-length backstrap for double crossarm applications (option D or E) available with two (D) or four (E) mounting bolts.

Adjust the bolt heads in the switch base slots as needed to closely fit the crossarms. Tighten mounting hardware to about 12-15 foot pounds.

Note: Four (4) bolts must be used when mounting on double crossarm.

3. Follow your utilities' standard procedures for dead-ending your conductors.
4. Before installing desired connectors on terminal pads. Consider using wire brush on terminal pads and electrical conductors and using oxidation inhibitor before inserting conductor into connector. Tighten connector hardware to about 12-15 foot-pounds.

D-73P-CD installation procedure

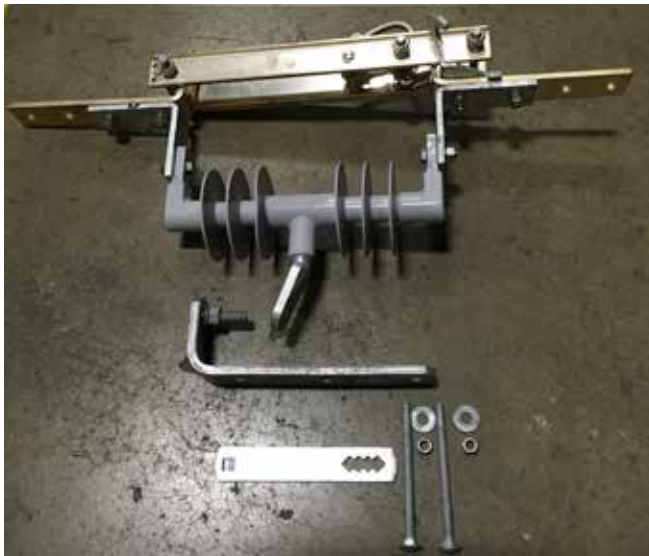

Figure 2. D-73P-CD parts.

The switch must be properly selected for each installation with consideration to continuous current, BIL, and rated voltage.

Mounting the switch

1. Securely attach the mounting bracket supplied with switch to the crossarm or pole per standard procedure. Assembly of cross-arm mounting bracket to cutout disconnect switch shown in Figure 3.

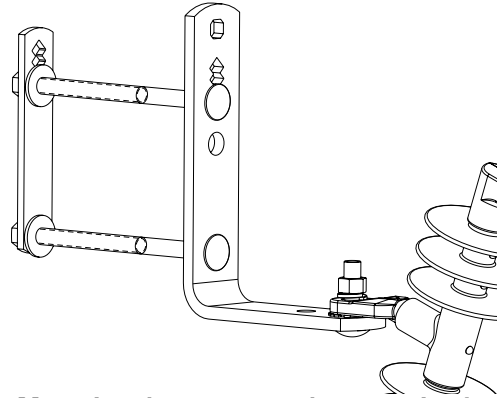

Figure 3. Mounting the cutout on the mounting bracket.

2. Mount the cutout on the mounting bracket making sure the external-tooth lockwasher is placed between the mounting bracket and the cutout disconnect switch bushing support pin (see Figure 4).

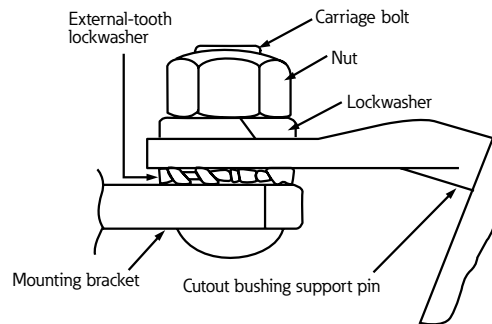

Figure 4. Proper cutout mounting.

3. Rotate the cutout disconnect switch and the mounting bracket to provide maximum clearance for the operator and maximum ease of operation.
4. Securely tighten the carriage bolt nut with 3/4" wrench.
5. Make electrical connections. When using aluminum conductors, wire brush conductors and apply a coating of oxidation inhibitor before inserting conductor into connector.

D-73P-TS installation procedure

The switch must be properly selected for each installation with consideration to continuous current, BIL, and rated voltage.



Figure 5. D-73P-TS switch.

Mounting the switch

1. Eaton's D-73P-TS in-line tension switch comes equipped with blade stop pin to provide 90 degree blade opening stop. Optional 150 degree stop (option A) available to provide positive stop at 150 degree opening. See Figure 5 for blade stop used in in-line tension switch.
2. The D-73P-TS switch is made for mounting directly in the line, safely supporting the conductor while providing necessary insulation gap for fast and safe line maintenance.
3. In-line tension switch can come equipped with optional connector accessories; parallel groove connectors (option P) or 4 terminal bolts and hardware (option Y) to be used for connecting industry standard terminals to switch contact pads.
4. Follow your utilities' standard procedures for dead-ending your conductors.
5. Before installing desired connectors on contact pads. Consider using wire brush on terminal pads and electrical conductors and using oxidation inhibitor before inserting conductor into connector. Tighten connector hardware to about 12-15 foot-pounds.

D-73P-LT installation procedure

Mounting the switch

1. Eaton's D-73P-LT line-tap switch is able to be used with conductor hanger brackets in straight or angled configuration. If hangers are supplied with the switch, digits 10 and 11 will include H3, H4, or H5 suffix. See Table 1 and Figure 6 for proper base installation location.
2. The D-73P-LT switch comes equipped with blade stop pin to provide 90 degree blade opening stop. An optional 150 degree latch (option A) is available to provide positive latch at 150 degree opening. See Figure 1 for pin location if equipped with 150 degree positive latch.
3. The line-tap switch can come equipped with optional parallel groove connectors (option P) that can be installed directly to switch base. 9/16" holes matching standard NEMA® pad dimension comes standard with the switch, parallel groove connectors can be installed in these hole locations.
4. Before installing desired connectors on contact pads or switch base, consider using wire brush on terminal installation location and electrical conductors using oxidation inhibitor before inserting conductor into connector. Tighten connector hardware to about 12–15 ft-lbs.
5. Follow your utilities' standard procedures for dead-ending your conductors.

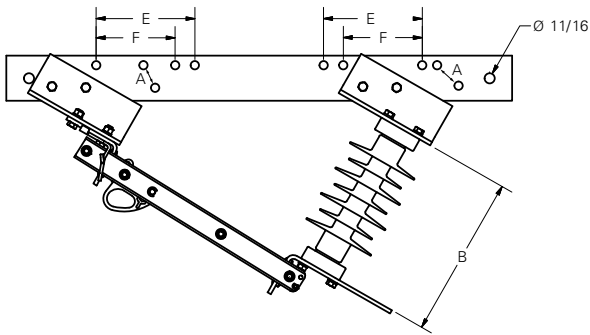
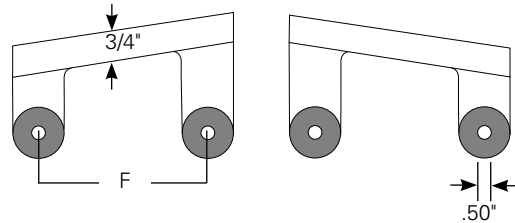

Figure 6. D-73P-LT hanger and connector installation.

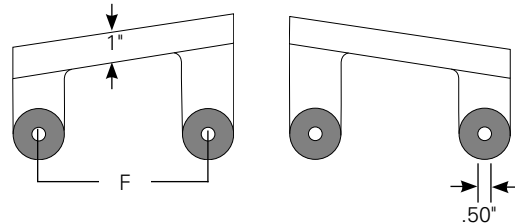

Figure 7. D-73-LT line-tap switch.

Angled Hanger Set 3/4" Diameter



Angled Hanger Set 1" Diameter



Straight Hanger Set 1" Diameter

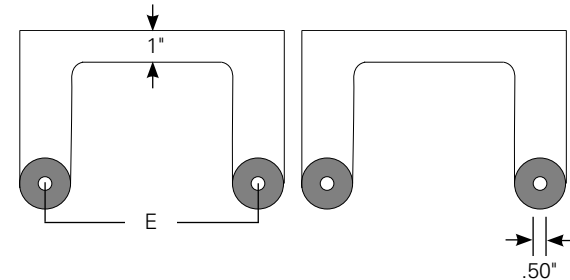

Table 1. Hanger Bracket Base Installation Location

Catalog Number	NEMA Terminal Pad	Insulator Length "B" (in.)	Line Tap Hanger Installation Location		
			3/4" Angled (H5)	1" Angled (H4)	1" Straight (H3)
D73LT1_ _ _ _	A	8.375	F	F	N/A
D73LT2_ _ _ _	A	8.375	F	F	N/A
D73LT3_ _ _ _	A	10.75	F	F	E
D73LT4_ _ _ _	A	10.75	F	F	E

Closing the switch

1. To close the D-73P line of switches, place the hookstick in the pull ring on the blade and rotate the blade to an intermediate position.
2. Look away from switch. Quickly and firmly drive the switch blade to the closed position.
3. To open the disconnect switch, place the hookstick in the pull ring on the blade. Look away from switch.

Quickly and firmly pull down towards the hinge end of the switch at a 45 degree angle. Once the switch blade is open complete the blade travel to its stop position.

Carefully remove hookstick from the pull ring.

4. All Eaton D-73P switches include loadbreak hooks as standard offering to be used with loadbreak tool. To open the switch under load, use only an approved loadbreak tool or device designed for use with switches. Follow the instructions provided with such tools.

Maintenance

Eaton's D-73P line of disconnect switches should require little maintenance. Following a program of periodic inspection and maintenance will prolong the life of the switches.

1. Operate the switch periodically to clean contact surfaces and to free moving parts
2. Check for burned or pitted contacts and replace if necessary
3. Inspect all blade spacers for looseness and if loose, tighten for even pressure across contacts.
4. Inspect mounting hardware and tighten as needed (12-15 ft-lb.)

This page is intentionally left blank.

This page is intentionally left blank.



Eaton
1000 Eaton Boulevard
Cleveland, OH 44122
United States
Eaton.com

**Eaton's Cooper Power Systems
Division**
2300 Badger Drive
Waukesha, WI 53188
Eaton.com/cooperpowerseries

© 2016 Eaton
All Rights Reserved
Printed in USA
Publication No. MN008004EN Rev 00
Supersedes S328101 Rev 0

Eaton is a registered trademark.

All trademarks are property
of their respective owners.

For Eaton's Cooper Power series product
information call 1-877-277-4636 or visit:
www.eaton.com/cooperpowerseries.