

UltraSIL[®] Polymer-Insulated CMU Outdoor Fuse Open Distribution Cutout Installation Instructions

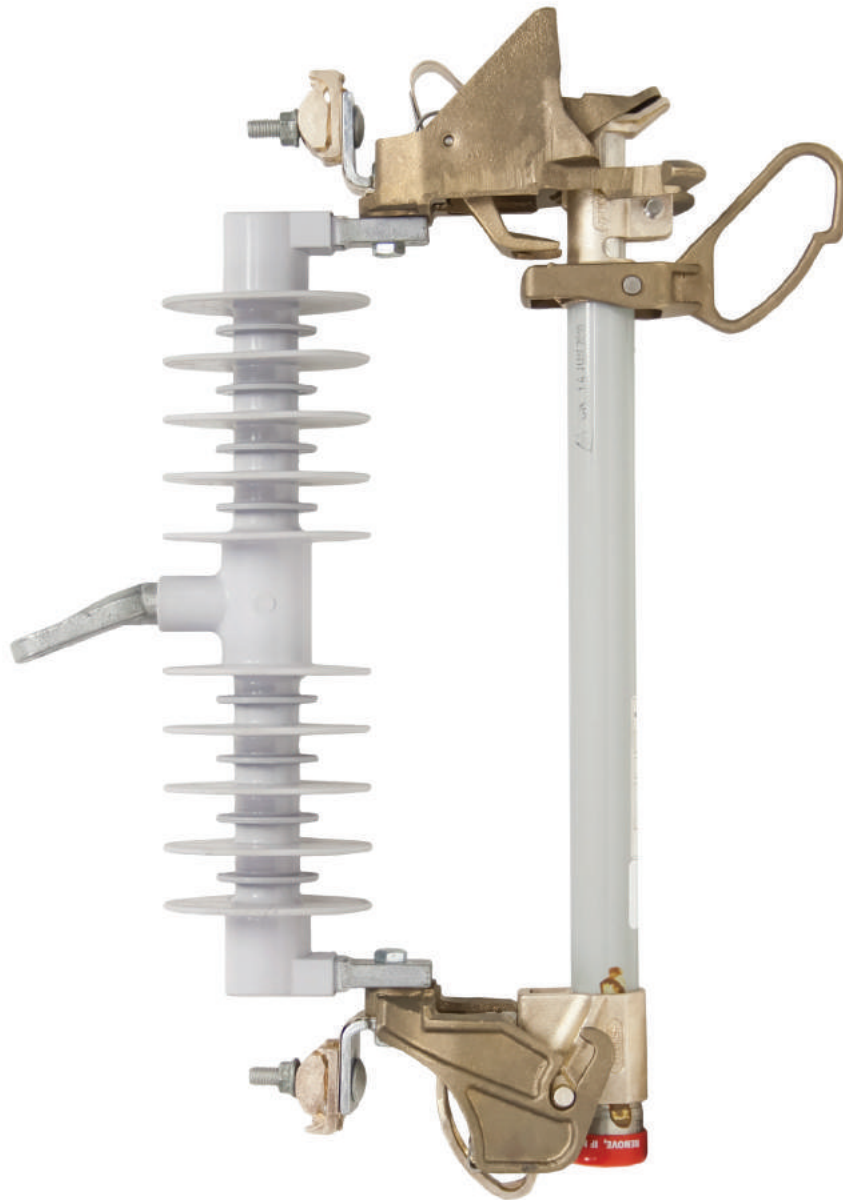

DISCLAIMER OF WARRANTIES AND LIMITATION OF LIABILITY

The information, recommendations, descriptions and safety notations in this document are based on Eaton Corporation's ("Eaton") experience and judgment and may not cover all contingencies. If further information is required, an Eaton sales office should be consulted. Sale of the product shown in this literature is subject to the terms and conditions outlined in appropriate Eaton selling policies or other contractual agreement between Eaton and the purchaser.

THERE ARE NO UNDERSTANDINGS, AGREEMENTS, WARRANTIES, EXPRESSED OR IMPLIED, INCLUDING WARRANTIES OF FITNESS FOR A PARTICULAR PURPOSE OR MERCHANTABILITY, OTHER THAN THOSE SPECIFICALLY SET OUT IN ANY EXISTING CONTRACT BETWEEN THE PARTIES. ANY SUCH CONTRACT STATES THE ENTIRE OBLIGATION OF EATON. THE CONTENTS OF THIS DOCUMENT SHALL NOT BECOME PART OF OR MODIFY ANY CONTRACT BETWEEN THE PARTIES.

In no event will Eaton be responsible to the purchaser or user in contract, in tort (including negligence), strict liability or otherwise for any special, indirect, incidental or consequential damage or loss whatsoever, including but not limited to damage or loss of use of equipment, plant or power system, cost of capital, loss of power, additional expenses in the use of existing power facilities, or claims against the purchaser or user by its customers resulting from the use of the information, recommendations and descriptions contained herein. The information contained in this manual is subject to change without notice.

Contents

SAFETY INFORMATION

Safety information	iv
--------------------------	----

PRODUCT INFORMATION

Introduction	1
Acceptance and initial inspection	1
Handling and storage	1
Standards	1

INSTALLATION PROCEDURE

Mounting the cutout	2
Connecting electrical leads	2
Installing fuse	2

OPERATION

Removal of a fuse	5
-------------------------	---

DIMENSIONAL INFORMATION

Dimensions	5
------------------	---



Safety for life



Eaton meets or exceeds all applicable industry standards relating to product safety in its Cooper Power™ series products. We actively promote safe practices in the use and maintenance of our products through our service literature, instructional training programs, and the continuous efforts of all Eaton employees involved in product design, manufacture, marketing, and service.

We strongly urge that you always follow all locally-approved safety procedures and safety instructions when working around high-voltage lines and equipment, and support our “Safety For Life” mission.

Safety information

The instructions in this manual are not intended as a substitute for proper training or adequate experience in the safe operation of the equipment described. Only competent technicians who are familiar with this equipment should install, operate, and service it.

A competent technician has these qualifications:

- Is thoroughly familiar with these instructions.
- Is trained in industry-accepted high- and low-voltage safe operating practices and procedures.
- Is trained and authorized to energize, de-energize, clear, and ground power distribution equipment.
- Is trained in the care and use of protective equipment such as arc flash clothing, safety glasses, face shield, hard hat, rubber gloves, clampstick, hotstick, etc.

Following is important safety information. For safe installation and operation of this equipment, be sure to read and understand all cautions and warnings.

Hazard Statement Definitions

This manual may contain four types of hazard statements:

DANGER

Indicates an imminently hazardous situation which, if not avoided, will result in death or serious injury.

WARNING

Indicates a potentially hazardous situation which, if not avoided, could result in death or serious injury.

CAUTION

Indicates a potentially hazardous situation which, if not avoided, may result in minor or moderate injury.

NOTICE

Indicates a potentially hazardous situation which, if not avoided, may result in equipment damage only.

Safety instructions

Following are general caution and warning statements that apply to this equipment. Additional statements, related to specific tasks and procedures, are located throughout the manual.

DANGER

Hazardous voltage. Contact with hazardous voltage will cause death or severe personal injury. Follow all locally-approved safety procedures when working around high- and low-voltage lines and equipment.

G103.3

WARNING

Before installing, operating, maintaining, or testing this equipment, carefully read and understand the contents of this manual. Improper operation, handling, or maintenance can result in death, severe personal injury, and equipment damage.

G101.0

WARNING

This equipment is not intended to protect human life. Follow all locally-approved procedures and safety practices when installing or operating this equipment. Failure to comply can result in death, severe personal injury, and equipment damage.

G102.1

WARNING

Power distribution and transmission equipment must be properly selected for the intended application. It must be installed and serviced by competent personnel who have been trained and understand proper safety procedures. These instructions are written for such personnel and are not a substitute for adequate training and experience in safety procedures. Failure to properly select, install, or maintain power distribution and transmission equipment can result in death, severe personal injury, and equipment damage.

G122.2

Product information

Introduction

Eaton's Cooper Power series UltraSIL Polymer insulated outdoor fuse holding cutout will accept CMU Fuses (See **Figure 1**). The cutout's primary function is to interrupt fault or overload current within its rating on a distribution line to protect the electric circuit and/or connected equipment.

Read this manual first

Read and understand the contents of this manual and follow all locally approved procedures and safety practices before installing or operating this equipment.

Additional information

These instructions cannot cover all details or variations in the equipment, procedures, or process described nor provide directions for meeting every possible contingency during installation, operation, or maintenance. For additional information, contact your representative.

Acceptance and initial inspection

Each cutout is in good condition when accepted by the carrier for shipment. Upon receipt, inspect the shipping container for signs of damage. Unpack the cutout and inspect it thoroughly for damage incurred during shipment. If damage is discovered, file a claim with the carrier immediately.

Handling and storage

Be careful during handling and storage of the fuse cutout combination to minimize the possibility of damage. If the cutout is to be stored for any length of time prior to installation, provide a clean, dry storage area.

Standards

ISO 9001 Certified Quality Management System

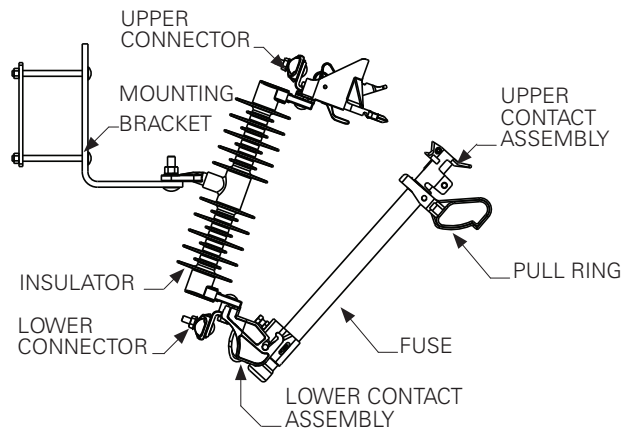

Figure 1. UltraSIL Polymer-Insulated CMU fuseholder cutout assembly

Installation procedure

The fuseholder must be properly selected for each installation with consideration to recovery voltage,

continuous current (fuse rating), basic insulation level (BIL) and fault interrupting rating.

Mounting the cutout

1. **Securely attach the mounting bracket**, if supplied with the cutout, to the crossarm or pole per standard procedure.

NOTICE

Do not mount this cutout in vaults or other enclosed areas because of the expulsion emitted during fault interruption when using a fuseholder. The result could be equipment damage to the cutout and other equipment in the vicinity.

2. **Mount the cutout on the mounting bracket** making sure the external-tooth lockwasher is placed between the mounting bracket and the cutout bushing support pin (See **Figure 2**). Tighten the nut by hand.
3. **Rotate the cutout and the mounting bracket** to provide maximum clearance for the operator and maximum ease of operation.
4. **Securely tighten** the carriage bolt nut with a 3/4" wrench.

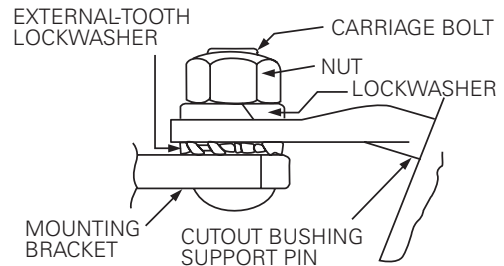

Figure 2. Mounting the cutout to the mounting bracket

Connecting electrical leads

1. **Loosen upper and lower connectors** (See **Figure 1**).
2. **When using aluminum conductors, wire brush conductors and apply a coating of oxidation inhibitor** before inserting conductor into connector.
3. **Tighten upper and lower connectors** to a maximum 20 ft-lbs.

Table 1. Cutout connectors — eye bolt or parallel groove

Connector	Size	Connector Cable Range
Upper	Large	#6 (0.204) to 250 MCM (0.575)
Lower	Large	#6 (0.204) to 250 MCM (0.575)

Installation (fusing) in outdoor mountings

Attach the fuse end fittings (See **Figure 3**) as follows:

1. The lower end fitting must be attached first. Slip the lower end fitting over the upper end of the fuse and slide it down until the locating slot seats on the locating pin on the lower ferrule of the fuse. Next, back off the locknut on the clamp screw and tighten the clamp screw firmly (90 - 100 in-lbs.); secure it with the locknut.
2. Slip the upper end fitting over the fuse. Align the locating pin (inside the upper end fitting) with the locating slot in the fuse and seat the upper end fitting firmly against the upper end of the fuse. Tighten the clamp screw firmly (160 - 180 in-lbs.). **Do not remove the outer cap from the bottom of the fuse.**

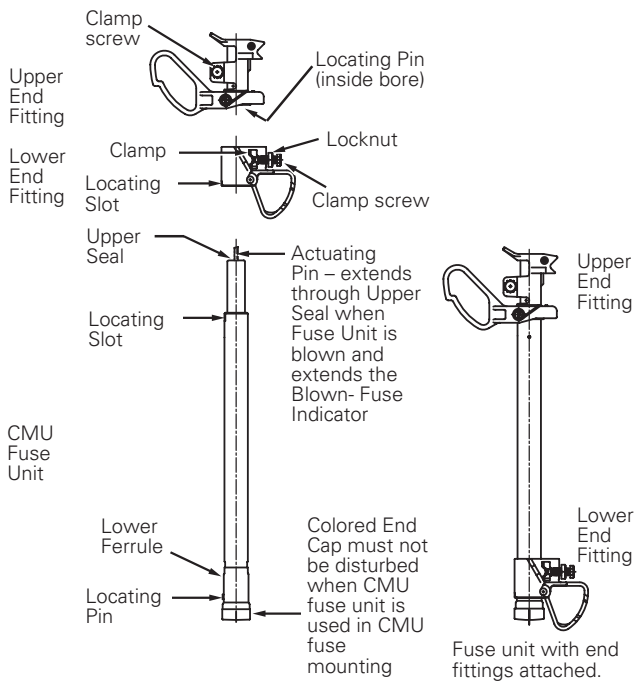

Figure 3. Outdoor CMU fuse fittings

Installing a fuse into the fuseholder cutout

Once the end fittings for the fuse have been installed on the fuse

1. **Insert the hook stick** into the fuse's lower end fitting lifting ring.
2. **Place the fuse into the hinge** of the cutout (See **Figure 4**).
3. Remove the hook stick.
4. **After positioning oneself well clear of the vented end and exhaust path of the cutout**, the operator should place the hook stick in the pull ring on the upper ferrule of the fuse.
5. **Rotate the fuse** to an intermediate position as in (See **Figure 5**).

6. **While looking away from the cutout**, quickly and firmly drive the fuse into the closed position.

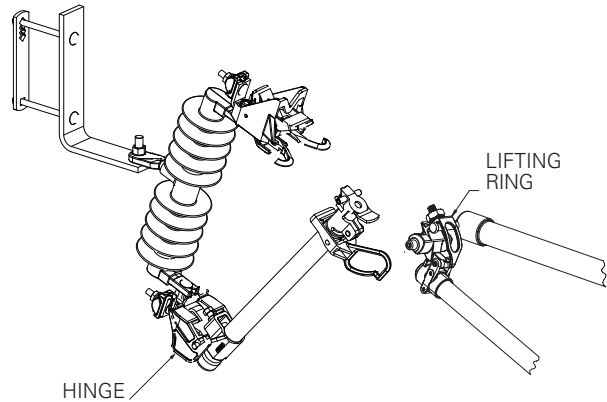

Figure 4. Inserting the fuse into the UltraSIL Polymer-Insulated fuse holder cutout

7. **Remove the hook stick** from the pull ring carefully to avoid opening the fuseholder.

CAUTION

Do not attempt to interrupt load current by pulling on the fuseholder pull ring to open the cutout. An arc started by opening a cutout under load in this manner could cause injury or damage to equipment.

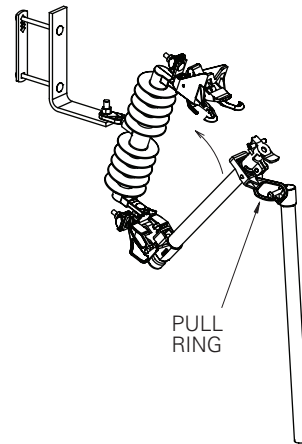

Figure 5. Closing the fuse into the UltraSIL Polymer-Insulated cutout

Operation

When the fuse clears a fault, the dropout mechanism should allow it to drop open in the cutout.

CAUTION

Only qualified personnel should operate a cutout. Such personnel should always wear appropriate protective equipment such as rubber gloves, hard hats, safety glasses, etc., in accordance with established utility and safety practices.

Removal of a fuse

1. **Insert a hook stick into the lifting ring of the fuse** and remove it from the lower contact assembly of the cutout.
2. Remove the end fittings from the operated fuse. With a new fuse and removed end fittings, follow the installation instructions on page 2 starting with **Installation (fusing) in outdoor mountings**.

Dimensional information

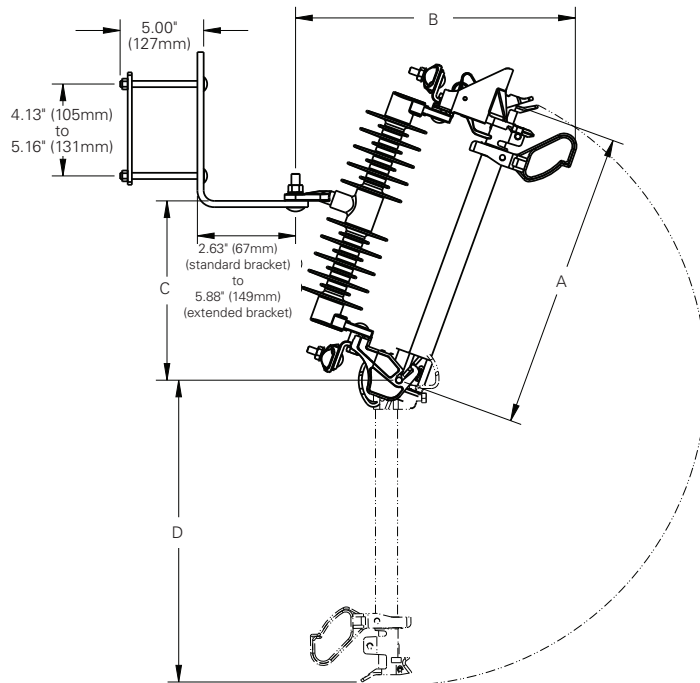

Figure 6. UltraSIL polymer-insulated fuseholder cutout assembly (See Table 2)

Table 2. UltraSIL polymer-insulated dimensional data

Voltage Rating kV	BIL kV	Dimensions inches (mm)			
		A	B	C	D
17.1	150	17.91 (455)	16.74 (425)	10.77 (274)	18.13 (461)
27.1	150	21.13 (537)	17.25 (438)	12.63 (321)	21.88 (556)



Eaton
1000 Eaton Boulevard
Cleveland, OH 44122
United States
Eaton.com

Eaton's Power Systems Division
2300 Badger Drive
Waukesha, WI 53188
Eaton.com/cooperpowerseries

EAT•N
Powering Business Worldwide

© 2019 Eaton
All Rights Reserved
Printed in USA
MN132034EN Rev 01

Eaton is a registered trademark.

All trademarks are property
of their respective owners.

For Eaton's Cooper Power series product
information call 1-877-277-4636 or visit:
www.eaton.com/cooperpowerseries.