

# UltraSIL™ polymer-housed VariSTAR™ Type UI intermediate-class surge arresters



## General

Eaton has set a new standard of excellence for polymer-housed intermediate-class surge arresters. Eaton's Cooper Power™ series UltraSIL™ polymer-housed VariSTAR™ Type UI intermediate-class arresters incorporate the industry recognized superior silicone rubber housing with a unique high creep alternating shed profile designed to withstand the most extreme environments. The "standard" silicone rubber housing is designed with a minimum specific creepage distance of 31 mm/kV L-L, which meets category IV (Very Heavy) pollution level according to the IEC standard. This housing is applied over a gapless MOV internal design.

Type UI arresters from Eaton meet or exceed the requirements of IEEE Std C62.11™-2005 standard including Short Circuit Tests performed in accordance with IEEE Std C62.11a™-2008 standard.

**EATON**

*Powering Business Worldwide*

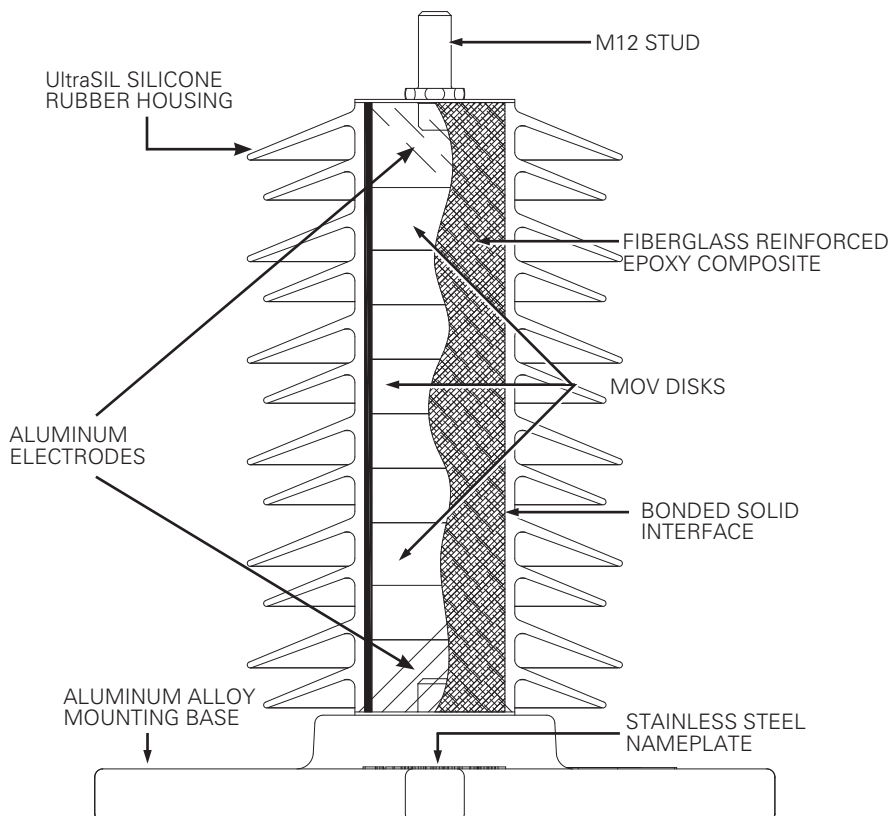

**Figure 1. Cutaway illustration of 10 kV UltraSIL polymer-housed VariSTAR intermediate-class arrester.**

### Construction

The unique construction of UltraSIL polymer-housed intermediate-class arresters begins with world class Metal Oxide Varistor (MOV) disks produced at our dedicated manufacturing facility in Olean, NY. By manufacturing our own disks we maintain a strict quality control over the entire production process, from initial raw material inspections to final physical and electrical testing of each disk. In addition, by controlling the manufacturing process of both disks and arresters, we achieve the optimal combination. Eaton produces MOV disks of unsurpassed quality through continuous improvements in disk formulation and manufacturing technology. The end result is a long history of in-service use with outstanding durability and protective capability.

Arrester production begins by stacking glass-collared MOV disks in series with aluminum end electrodes. Our proprietary process wraps the assembly with a high-strength woven fiberglass-reinforced epoxy composite. When cured, the arrester module is capable of withstanding extreme electrical and cantilever loading conditions.

The UltraSIL silicone rubber housing utilizes an interference fit and is bonded onto the internal module to form a solid, void free, high-dielectric strength insulation system. Once the housing is in place, each arrester must pass a strict series of electrical tests to insure the highest level of in-service performance.

The silicone rubber housing results in lighter weight than similarly rated porcelain housed arresters. The silicone rubber housing is also less sensitive to physical damage than porcelain.

### Features

The UltraSIL silicone rubber housing was selected for its superior insulation performance when compared to other polymeric housing

**Table 1. UltraSIL (UI) Intermediate-Class Ratings and Characteristics**

Arrester Characteristic	Rating
Arrester Voltage Ratings (kV)	3-108
Rated Discharge Energy (kJ/kV of MCOV)	3.9
Single Impulse Rating	
System Frequency (Hz)	50/60
Impulse Classifying Current (kA)	10
High Current withstand* (kA)	100
Pressure Relief Rating,** kA rms sym.	40
Cantilever Strength (in-lbs) UI (3-108 kV)	Ultimate 10,000 MDCL Static† 4,000

\* High current, short duration withstand within one minute (100 kA, 4/10 μs).

\*\* Cubicle Mount Pressure Relief Rating is 40 kA rms sym.

† Maximum design cantilever load-static or maximum working load is 40% of the ultimate.

materials. Long term environmental testing has verified the lifetime performance advantage silicone rubber provides.

Independent laboratory tests have verified the superior water repellent behavior of silicone rubber, which is responsible for the lower external power losses, higher resistance to UV degradation and surface tracking, superior performance in contaminated environments, and other important insulating properties. Also, UltraSIL silicone rubber has been proven not to support biological growth and is non-flammable.

The standard silicone rubber housed arrester can be customized with a variety of terminal and mounting options which allow users to select the features that meet their application needs. Eaton provides high creep silicone rubber housings for standard arrester designs equivalent to 31 mm/kV or 1.22"/kV. Customers who require longer creepage housings can easily select a different housing option through the catalog numbering system. See page 8 for a complete list of available options.

### Operation

The operation of the VariSTAR Type UI intermediate-class arrester is typical of gapless metal oxide arresters. During steady-state conditions, line-to-ground voltage is applied continuously between the line and ground terminals of the arrester. When surges occur, the arrester immediately limits, or clamps, the overvoltage condition by conducting the surge current to ground. After passage of the surge, the arrester returns to its initial state, conducting minimal leakage current. This minimal leakage current (which is primarily capacitive, with a small resistive component) can be tolerated on a continuing basis.

The UltraSIL polymer-housed intermediate-class Type UI arrester easily surpasses the minimum fault current withstand requirements for intermediate-class arresters as defined in IEEE

Std C62.11a™-2008 standard (16.1 kA). These arresters have been tested and shown to withstand fault currents exceeding 40 kA. During these tests, the silicone rubber housing ruptures without expelling internal parts.

Type UI arresters are ideal for protection against repeated high energy switching surges and provide reliable protection for substation equipment, capacitor banks, multiple lines, and cable circuits. They are also ideal for applications where lighter weight and shorter heights (when compared to porcelain housed arresters) are critical.

### Design testing

The housing, internal components, and hardware of an arrester must work together as a system. This system must stand up to years of service while being subjected to a wide range of environmental and electrical stresses. To assure a superior level of performance, both arrester components and finished arresters have been subjected to a series of tests that accurately represents years of exposure to actual field conditions. This testing far exceeds the requirements of industry standards.

The Type UI arrester has also met or exceeded all requirements for Intermediate-Class arresters as defined by IEEE Std C62.11™-2005 standard. Reference *CP1121 UltraSIL Polymer-Housed VariSTAR Type UI Intermediate-Class Surge Arresters Certified Test Report*.

The Type UI arrester is USDA's Rural Utilities Service (RUS) Section ae approved, meeting or exceeding all RUS technical specification and workmanship.

### Production tests

Eaton has implemented a complete production test program to ensure a quality product. Each MOV disk is subjected to a series of electrical tests to maintain quality. We also perform additional tests on every MOV disk batch. Listed below are the tests performed on the MOV disks:

- 100% Physical Inspection
- 100% Discharge Voltage Test
- 100% Vref at 6 mA
- 100% Watt Loss Measured at 1.05 x MCOV
- 100% Transmission Line Discharge Energy Test
- Batch High-Current, Short-Duration Test
- Batch Thermal Stability Test
- Batch Aging Test

Each fully assembled UltraSIL polymer-housed intermediate-class arrester also must pass the following production tests:

- 100% Physical Inspection
- 100% Vref Test
- 100% Watt Loss Test
- 100% Partial Discharge Inception Voltage Test

### General application recommendations

The rating of an arrester is the maximum power-frequency line-to-ground voltage at which the arrester is designed to pass an operating duty-cycle test (as defined in IEEE Std C62.11™-2005 standard). Table 2 provides a general application guide for the selection of the proper arrester rating for a given system voltage and grounding configurations as outlined in IEEE Std C62.22™-2009 standard, which is the application guide for metal oxide surge arresters.

Under fault conditions and other system anomalies, higher than normal voltages can be imposed upon an arrester. With an improper arrester selection, these abnormal system voltages can cause an arrester to fail. To help ensure that the proper arrester is selected, Eaton application engineers are available to make recommendations.

**Table 2. Recommended Arrester Applications for VariSTAR Intermediate-Class Arresters**

System Voltage (kV rms)		Recommended Arrester Rating (MCOV) kV rms	
Nominal	Maximum	Three-Wire or Four-Wire Wye Solidly Grounded Neutral	Delta and Ungrounded Wye
2.4	2.52	3 (2.55)	3 (2.55)
4.16	4.37	3 (2.55)	6 (5.10)
4.8	5.04	—	6 (5.10)
6.9	7.25	6 (5.10)	9 (7.65)
8.32	8.74	6 (5.10)	9 (7.65) 10 (8.40)
12.0	12.7	9 (7.65) 10 (8.40)	12 (10.2) 15 (12.7)
12.47	13.2	9 (7.65) 10 (8.40)	15 (12.7) 18 (15.3)
13.2	13.97	10 (8.40) 12 (10.2)	15 (12.7) —
13.8	14.5	10 (8.40) 12 (10.2)	15 (12.7) 18 (15.3)
20.78	21.8	15 (12.7) 21 (17.0)	24 (19.5) 27 (22.0)
22.9	24.2	18 (15.3) 21 (17.0)	24 (19.5) —
24.9	26.4	18 (15.3) 21 (17.0)	24 (19.5) 27 (22.0)
34.5	36.5	27 (22.0) 30 (24.4)	36 (29.0) 39 (31.5)
46	48.3	36 (29.0) 39 (31.5)	48 (39.0) —
69	72	54 (42.0) 60 (48.0)	72 (57.0) —
115	121	90 (70.0) 96 (76.0)	108 (84.0) —
138	145	108 (84.0)	—

The following information is normally required:

1. Maximum system operating voltage.
2. System grounding conditions;
  - A. For four-wire circuits, grounding conditions depend upon whether the system is multi-grounded, whether it has a neutral impedance and whether common primary and secondary neutrals are used.
  - B. For three-wire circuits, grounding conditions depend upon whether the system is solidly grounded at the source, grounded through neutral impedance at the source transformers or ungrounded.
3. Available Fault Current.
4. Maximum line-to-ground voltage and overvoltage duration during fault conditions.

Contact your Eaton representative to have your individual system application needs reviewed.

### Temporary overvoltage (TOV) withstand ability

The UltraSIL polymer-housed intermediate-class arrester's ability to withstand 60 Hz overvoltage conditions (TOVs) is shown in Figure 2. The graph illustrates the time an arrester can survive such a voltage, and recover, without going into thermal runaway for a given voltage magnitude (expressed in Per Units of arrester MCOV).

The graphs in Figure 2 show TOV withstand ability, with and without prior duty. The prior duty curve is based upon absorption of rated energy immediately preceding application of the overvoltage which is 3.9 kJ/kV of MCOV.

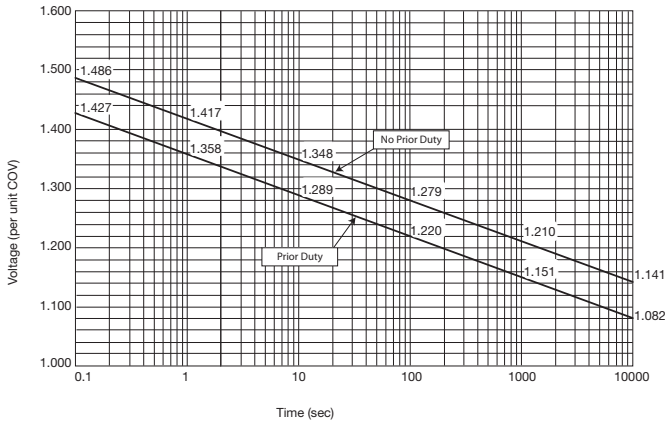

**Figure 2. Temporary overvoltage curve – 60° ambient temperature.**

**Note:** The TOV curve in Figure 2 applies to standard electrical build arresters. Consult manufacturer for further information regarding alternate electrical builds.

### Mounting information

The standard base of the UltraSIL polymer-housed Type UI arrester is designed for mounting on 8.75" or 10" diameter bolt circle patterns. The three mounting holes are each spaced 120° from the others and are designed to handle 0.5" diameter bolts. Mounting hardware (bolts, nuts, and washers) is not included with the arrester. See Figure 3 for mounting base details.

The UltraSIL polymer-housed Type UI arrester has an ultimate cantilever strength rating of 10,000 in-lbs. An inherently strong design allows the UltraSIL arrester to be mounted in a variety of ways. These arresters can be mounted vertically, with attachment at the base, suspension (underhung) mounted or cubicle mounted. In order to underhang the arrester the proper orientation of the mounting base is required. UltraSIL polymer-housed intermediate-class Type UI arresters can also be horizontally mounted through 108 kV. Please select the proper mounting arrangement option in the catalog number as shown in Table 6. Contact your local Eaton representative for further mounting configuration details.

### Ordering information

Table 6 includes the standard catalog numbers for Type UI arresters. The arrester represented by the standard catalog number is configured with the connectors and mounting arrangement shown in Figure 5 ("45" in digits 11 and 12 of Table 7). Eaton offers many other options that allow customers to select specific features they desire. Options on housing sizes, hardware and mounting options are available and defined in Table 7. This table allows customers who may prefer options different from those in our standard Figure 5 configuration to develop a catalog number which provides the unique features they desire. For additional assistance please contact your Eaton representative.

### Protective characteristics

All UltraSIL polymer-housed intermediate-class arresters provide excellent overvoltage protection for electrical equipment. The specific protective characteristics for each arrester rating are shown on the next page in Table 4.

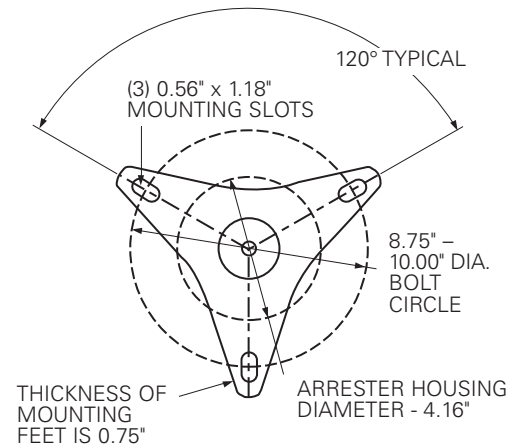

**Figure 3. Mounting base details.**

**Table 3. Protective Characteristics of the UltraSIL Polymer-Housed UI Arrester**

Arrester Rating (kV, rms)	Arrester MCOV (kV, rms)	TOV*		Front-of-wave Protective Level (kV Crest)**	Maximum Discharge Voltage (kV Crest) 8/20µs Current						Switching Surge Protection Level (kV Crest)			
		1 sec	10 Sec		1.5 kA	3 kA	5 kA	10 kA	20 kA	40 kA	125 A	250 A	500 A****	1000 A
3	2.55	3.5	3.3	8.8	6.8	7.2	7.6	8.3	9.1	10.4	5.9	6.1	6.3	6.6
6	5.1	6.9	6.6	17.5	13.6	14.4	15.2	16.6	18.2	20.7	11.8	12.1	12.5	13.1
9	7.65	10.4	9.9	26.2	20.4	21.6	22.7	24.9	27.3	31.1	17.7	18.1	18.8	19.6
10	8.4	11.4	10.8	28.8	22.4	23.7	24.9	27.3	29.9	34.1	19.4	19.9	20.6	21.5
12	10.2	13.9	13.1	34.9	27.2	28.8	30.3	33.1	36.3	41.4	23.5	24.1	25	26.1
15	12.7	17.2	16.4	43.5	33.8	35.8	37.7	41.3	45.2	51.5	29.3	30.1	31.1	32.5
18	15.3	20.8	19.7	52.4	40.8	43.1	45.4	49.7	54.5	62.1	35.3	36.2	37.5	39.1
21	17	23.1	21.9	58.2	45.3	47.9	50.4	55.2	60.5	69	39.2	40.2	41.6	43.5
24	19.5	26.5	25.1	66.7	51.9	55	57.8	63.3	69.4	79.1	44.9	46.1	47.8	49.8
27	22	29.9	28.4	75.3	58.6	62	65.2	71.4	78.3	89.2	50.7	52	53.9	56.2
30	24.4	33.1	31.5	83.5	65	68.8	72.3	79.2	86.8	98.9	56.2	57.7	59.8	62.4
33	27.5	37.3	35.4	94.1	73.2	77.5	81.5	89.3	97.9	112	63.3	65	67.3	70.3
36	29	39.4	37.4	99.2	77.2	81.7	86	94.2	104	118	66.8	68.6	71	74.1
39	31.5	42.8	40.6	108	83.9	88.8	93.4	103	113	128	72.5	74.5	77.1	80.5
42	34	46.2	43.8	117	90.5	95.8	101	111	121	138	78.3	80.4	83.2	86.9
45	36.5	49.6	47	125	97.2	103	109	119	130	148	84	86.3	89.4	93.3
48	39	53	50.3	134	104	110	116	127	139	159	89.8	92.2	95.5	99.6
54	42	57	54.1	144	112	119	125	137	150	171	96.7	99.3	103	108
60	48	65.2	61.9	165	128	136	143	156	171	195	111	114	118	123
66	53	72	68.3	182	142	150	158	172	189	215	122	126	130	136
72	57	77.4	73.5	195	152	161	169	185	203	232	132	135	140	146
78	62	84.2	79.9	213	165	175	184	202	221	252	143	147	152	159
84	68	92.3	87.7	233	181	192	202	221	242	276	157	161	167	174
90	72	97.8	92.8	247	192	203	214	234	257	292	166	171	177	184
96	76	103.2	98	260	203	215	226	247	271	309	175	180	186	195
108	84	114.1	108.3	288	224	237	249	273	299	341	194	199	206	215

\* Temporary Overvoltage (TOV) with Prior Duty.

\*\*\* Contact manufacturer for alternate electrical builds.

\*\* Based on a 10 kA current impulse that results in a discharge voltage cresting in 0.5 µs

\*\*\*\* 45-60 µs rise time for a 500 A peak current surge.

**Table 4. Creepage Distances and Insulation Withstand Voltages of UI Intermediate Class Arresters**

Arrester Rating (kV, rms)	Arrester MCOV (kV, rms)	Catalog Number	Creepage Distance (inches)	Insulation Withstand Voltages		
				1.2/50 Impulse (kV, crest)	60Hz, Dry 60 Seconds (kV, rms)	60Hz, Wet 10 Seconds (kV, rms)
3	2.55	UIAA003002A0645A11	23.1	86	60	48
6	5.1	UIAA006005A0645A11	23.1	86	60	48
9	7.65	UIAA009007A0845A11	30.8	115	80	64
10	8.4	UIAA010008A0845A11	30.8	115	80	64
12	10.2	UIAA012010A0845A11	30.8	115	80	64
15	12.7	UIAA015012A0845A11	30.8	115	80	64
18	15.3	UIAA018015A1045A11	38.5	134	94	75
21	17	UIAA021017A1045A11	38.5	134	94	75
24	19.5	UIAA024019A1245A11	46.2	156	109	88
27	22	UIAA027022A1445A11	53.8	176	123	101
30	24.4	UIAA030024A1445A11	53.8	176	123	101
33	27.5	UIAA033027A1645A11	61.5	202	140	113
36	29	UIAA036029A1645A11	61.5	202	140	113
39	31.5	UIAA039031A1845A11	69.1	218	151	126
42	34	UIAA042034A1845A11	69.1	218	151	126
45	36.5	UIAA045036A2045A11	76.8	238	164	139
48	39	UIAA048039A2245A11	84.5	252	172	152
54	42	UIAA054042A2245A11	84.5	252	172	152
60	48	UIAA060048A2645A11	99.9	321	211	188
66	53	UIAA066053A2645A11	99.9	294	201	173
72	57	UIAA072057A2845A11	108.0	316	212	187
78	62	UIAA078062A3445A11	130.6	418	291	239
84	68	UIAA084068A3645A11	138.3	434	302	252
90	72	UIAA090072A3845A11	146.0	454	315	265
96	76	UIAA096076A4045A11	153.6	474	328	278
108	84	UIAA108084A4445A11	169.0	504	344	304

### Dimensions, weight and spacing requirements

Figure 4 illustrates a three-phase in-line mounting arrangement. Dimensions C and D reference minimum phase-to-ground and phase-to-phase distances, respectively. These dimensions are listed in Table 5. Figure 5 shows an outline drawing of the standard UltraSIL polymer-housed Type UI intermediate-class arrester, which is also listed in Table 5.

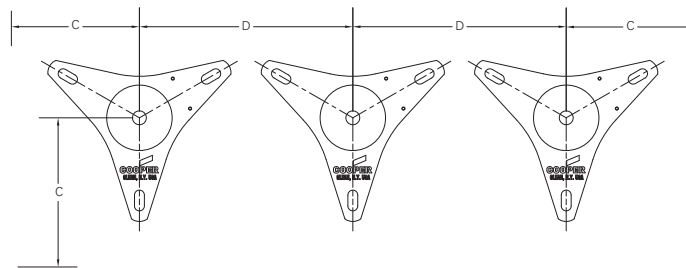

Figure 4. Three-phase in-line mounting arrangement.

Table 5. Dimensions, Clearance Requirements, and Weights of UI Intermediate-Class Arresters

Arrester Rating (kV, rms)	Arrester MCOV (kV, rms)	Catalog Number	Figure 5 Dim. "A" (inches)	Figure 5 Dim. "B" (inches)	Figure 4 Dim. "C" Minimum Phase-to-Ground Clearance (inches)	Figure 4 Dim. "D" Minimum Phase-to-Phase Clearance (inches)	Weight (lbs.)
3	2.55	UIAA003002A0645A11	6.3	5.2	5.5	10	6.7
6	5.1	UIAA006005A0645A11	6.3	5.2	5.5	10	6.7
9	7.65	UIAA009007A0845A11	7.9	5.2	5.9	10.4	6.7
10	8.4	UIAA010008A0845A11	7.9	5.2	6.1	10.6	6.7
12	10.2	UIAA012010A0845A11	7.9	5.2	6.6	11.1	6.7
15	12.7	UIAA015012A0845A11	7.9	5.2	7.5	12	6.7
18	15.3	UIAA018015A1045A11	9.4	5.2	8.6	13.1	8.9
21	17	UIAA021017A1045A11	9.4	5.2	9.3	13.8	8.9
24	19.5	UIAA024019A1245A11	11	5.2	9.5	14	8.9
27	22	UIAA027022A1445A11	12.5	5.2	10.5	15	8.9
30	24.4	UIAA030024A1445A11	12.5	5.2	11.5	16	8.9
33	27.5	UIAA033027A1645A11	14.1	5.2	12.7	17.2	11.1
36	29	UIAA036029A1645A11	14.1	5.2	13.3	17.8	11.1
39	31.5	UIAA039031A1845A11	15.6	5.2	14.3	18.8	11.1
42	34	UIAA042034A1845A11	15.6	5.2	15.2	19.7	11.1
45	36.5	UIAA045036A2045A11	17.1	5.2	16.2	20.7	13.3
48	39	UIAA048039A2245A11	18.7	5.2	17.2	21.7	13.3
54	42	UIAA054042A2245A11	18.7	5.2	18.4	22.9	13.3
60	48	UIAA060048A2645A11	21.8	5.2	20.8	25.3	15.5
66	53	UIAA066053A2645A11	21.8	5.2	22.7	27.2	15.5
72	57	UIAA072057A2845A11	23.4	5.2	24.3	28.8	17.7
78	62	UIAA078062A3445A11	28.2	5.2	26.3	30.8	19.9
84	68	UIAA084068A3645A11	29.7	5.2	28.7	33.2	19.9
90	72	UIAA090072A3845A11	31.2	5.2	30.2	34.7	22.1
96	76	UIAA096076A4045A11	32.8	5.2	31.8	36.3	22.1
108	84	UIAA108084A4445A11	35.9	5.2	35	39.5	24.3

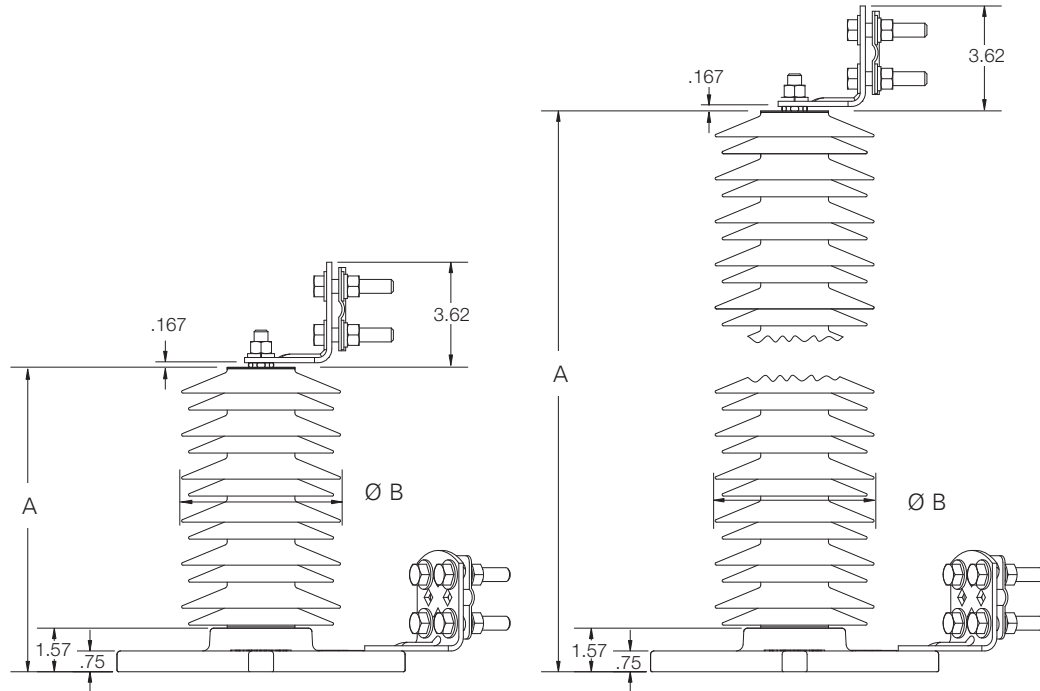

Figure 5. Outline drawing of standard UltraSIL Polymer-Housed Intermediate-Class Arresters (for standard catalog numbers see Table 3).

Table 6. Catalog Numbers for Standard Configuration

Arrester Rating (kV, rms)	UI	Arrester Rating (kV, rms)	UI	Arrester Rating (kV, rms)	UI	Arrester Rating (kV, rms)	UI
3	UIAA003002A0645A11	21	UIAA021017A1045A11	42	UIAA042034A1845A11	72	UIAA072057A2845A11
6	UIAA006005A0645A11	24	UIAA024019A1245A11	45	UIAA045036A2045A11	78	UIAA078062A3445A11
9	UIAA009007A0845A11	27	UIAA027022A1445A11	48	UIAA048039A2245A11	84	UIAA084068A3645A11
10	UIAA010008A0845A11	30	UIAA030024A1445A11	54	UIAA054042A2245A11	90	UIAA090072A3845A11
12	UIAA012010A0845A11	33	UIAA033027A1645A11	60	UIAA060048A2645A11	96	UIAA096076A4045A11
15	UIAA015012A0845A11	36	UIAA036029A1645A11	66	UIAA066053A2645A11	108	UIAA108084A4445A11
18	UIAA018015A1045A11	39	UIAA039031A1845A11				

Table 7. UltraQUIK Catalog Numbering System for UltraSIL Polymer-Housed Intermediate-Class Arresters

1	U	2	I	3	A	4	A	5		6		7		8		9		10		11	A	12		13		14		15		16		17		18	
---	---	---	---	---	---	---	---	---	--	---	--	---	--	---	--	---	--	----	--	----	---	----	--	----	--	----	--	----	--	----	--	----	--	----	--

**Catalog Number Digits:**

- 1 = "U" (UltraSIL Polymer-Housed Arrester)
- 2 = "I" (Intermediate-Class Arrester)
- 3 = "A" Standard Electrical Build\*  
\* Consult manufacturer for further information regarding alternate electrical builds.
- 4 = "A" Standard Cantilever Strength Design
- 5 through 10 = Arrester Rating: Duty-cycle (MCOV)

<b>003002</b> = 3 kV (2.55 kV)	<b>027022</b> = 27 kV (22.0 kV)	<b>060048</b> = 60 kV (48.0 kV)
<b>006005</b> = 6 kV (5.1 kV)	<b>030024</b> = 30 kV (24.4 kV)	<b>066053</b> = 66 kV (53.0 kV)
<b>009007</b> = 9 kV (7.65 kV)	<b>033027</b> = 33 kV (27.0 kV)	<b>072057</b> = 72 kV (57.0 kV)
<b>010008</b> = 10 kV (8.4 kV)	<b>036029</b> = 36 kV (29.0 kV)	<b>078062</b> = 78 kV (62.0 kV)
<b>012010</b> = 12 kV (10.2 kV)	<b>039031</b> = 39 kV (31.5 kV)	<b>084068</b> = 84 kV (68.0 kV)
<b>015012</b> = 15 kV (12.7 kV)	<b>042034</b> = 42 kV (34.0 kV)	<b>090072</b> = 90 kV (72.0 kV)
<b>018015</b> = 18 kV (15.3 kV)	<b>045036</b> = 45 kV (36.5 kV)	<b>096076</b> = 96 kV (76.0 kV)
<b>021017</b> = 21 kV (17.0 kV)	<b>048039</b> = 48 kV (39.0 kV)	<b>108084</b> = 108 kV (84.0 kV)
<b>024019</b> = 24 kV (19.5 kV)	<b>054042</b> = 54 kV (42.0 kV)	

11 = "A" Standard

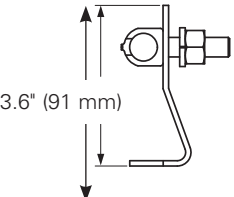
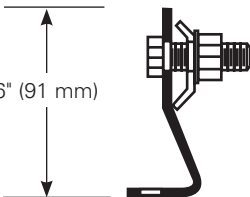
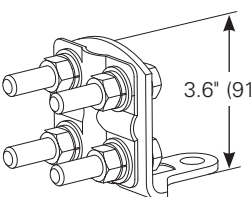
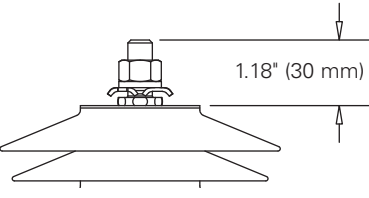



**Table 7. UltraQUIK Catalog Numbering System for UltraSIL Polymer-Housed Intermediate-Class Arresters (continued)**

1	U	2	I	3	A	4	A	5		6		7		8		9		10		11	A	12		13		14		15		16		17		18	
---	---	---	---	---	---	---	---	---	--	---	--	---	--	---	--	---	--	----	--	----	---	----	--	----	--	----	--	----	--	----	--	----	--	----	--

**14 = Line Terminal Options**

 <p><b>1 = Eyebolt Connector</b> Accepts copper or aluminum conductors from .16" dia. (#6) to .575" dia. (250 MCM)</p>	 <p><b>3 = Clamp Style Connector</b> Accepts copper or aluminum conductors from .16" dia. (#6) to .82" dia. (500 MCM)</p>	 <p><b>4 = NEMA Four-hole Pad</b> Accepts copper or aluminum conductors from .16" dia. (#6) to .82" dia. (500 MCM) <b>(Standard Option)</b></p>
 <p><b>5 = Wire Clamp</b> Accepts copper or aluminum conductors from .16" dia. (#6) to .575" dia. (250 MCM) (Cubicle Mount)</p>		

**15 = Ground Terminal Options**

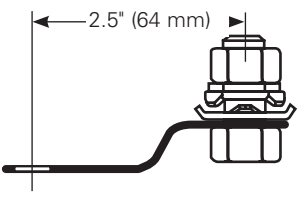
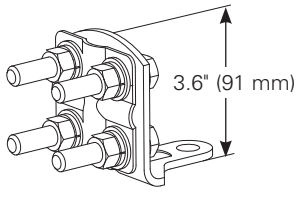
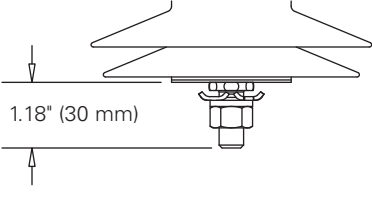
 <p><b>1 = Clamp Style Connector</b> Accepts copper or aluminum conductors from .16" dia. (#6) to .575" dia. (250 MCM)</p>	 <p><b>5 = NEMA Four-hole Pad</b> Accepts copper or aluminum conductors from .16" dia. (#6) to .82" dia. (500 MCM) <b>(Standard Option)</b></p>	 <p><b>B = Wire Clamp</b> Accepts copper or aluminum conductors from .16" dia. (#6) to .575" dia. (250 MCM) (Cubicle Mount)</p>
---	--	--

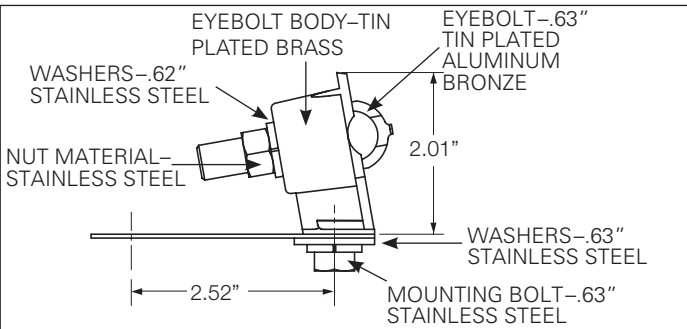

**9 = Eyebolt Connector**  
Accepts copper or aluminum conductors from .16" dia. (#6) to .575" dia. (250 MCM)

**Table 7. UltraQUIK Catalog Numbering System for UltraSIL Polymer-Housed Intermediate-Class Arresters (continued)**

1	U	2	I	3	A	4	A	5	6	7	8	9	10	11	A	12	13	14	15	16	17	18
---	---	---	---	---	---	---	---	---	---	---	---	---	----	----	---	----	----	----	----	----	----	----

**16 = Mounting Arrangement**

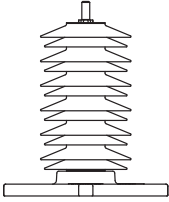
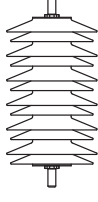
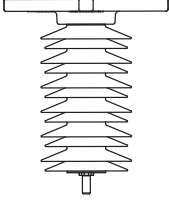
		
<p><b>A = Mounting Base Located on Bottom</b> <b>(Standard Option)</b></p>	<p><b>B = No Mounting Base</b> (Cubicle Mount) (UI Type 3-36 kV)</p>	<p><b>C = Mounting Base Located on Top</b> (Suspension Mount)</p>

- 17 = "1"** – Nameplate for Standard or Suspension Mount
- "2"** – Nameplate for Cubicle Mount (3-36 kV) Option Code "B" for digit 16.
- 18 = "1"** – Cardboard Packaging
- "2"** – Wood Crate Packaging

**Nameplate information**

A stainless steel nameplate is attached to the base of every UltraSIL polymer-housed Type UI arrester. The arrester catalog number, serial number, year of manufacture, duty-cycle ratings, MCOV ratings, and pressure relief rating are among the details provided on the nameplate. For cubicle mount arresters, the information is etched in the top plate of the arrester. See Figure 6 for an example of a blank nameplate.

**Additional information**

- S235-102-1, UltraSIL Polymer-Housed VariSTAR Type UI Intermediate-Class Surge Arresters Installation Instructions
- CP1121, UltraSIL Polymer-Housed VariSTAR Type UI Intermediate-Class Surge Arresters Certified Test Report

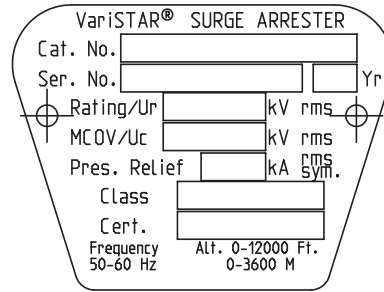

**Figure 6. Detail of blank nameplate.**

**Eaton**  
1000 Eaton Boulevard  
Cleveland, OH 44122  
United States  
Eaton.com

**Eaton's Cooper Power Systems Division**  
2300 Badger Drive  
Waukesha, WI 53188  
United States  
Eaton.com/cooperpowerseries

© 2015 Eaton  
All Rights Reserved  
Printed in USA  
Publication No. CA235012EN

Eaton, Cooper Power, VariSTAR and UltraSIL are valuable trademarks of Eaton in the U.S. and other countries. You are not permitted to use these trademarks without the prior written consent of Eaton.

IEEE is a registered trademark of the Institute of Electrical and Electronics Engineers, Inc. IEEE Std C62.11<sup>TM</sup>-2005, IEEE Std C62.22<sup>TM</sup>-2009 and IEEE Std 62.11a<sup>TM</sup>-2008 standards are trademarks of the Institute of Electrical and Electronics Engineers, Inc., (IEEE). This publication/product is not endorsed or approved by the IEEE.

For Eaton's Cooper Power series surge arrester product information call 1-877-277-4636 or visit: [www.eaton.com/cooperpowerseries](http://www.eaton.com/cooperpowerseries).