

UltraSIL™ polymer-housed VariSTAR™ type U3 surge arrester for systems through 275 kV IEC 10 kA; line discharge Class 3



General

Eaton has set a new standard of excellence for polymer-housed station-class surge arresters. Enhancements in arrester design allow Eaton to offer increased cantilever strength and improved energy handling capability. Eaton's Cooper Power series UltraSIL™ polymer-housed VariSTAR™ Type U3 station-class arresters incorporate the industry recognized superior silicone rubber housing with a unique high creep alternating shed profile designed to withstand the most extreme environments. The "standard" silicone rubber housing is designed with a minimum specific creepage distance of 31 mm/kV L-L, which meets category IV (Very Heavy) pollution level according to the IEC standard. This housing is applied over a gapless MOV internal design.

Eaton's Cooper Power series Type U3 arresters meet or exceed the requirements of IEC 60099-4 Rev 2009.

Construction

The unique construction of UltraSIL polymer-housed Class 3 arresters begins with world class Metal Oxide Varistor (MOV) disks produced at our manufacturing facility in Olean, NY. By manufacturing our own disks we maintain a strict quality control over the entire production process, from initial raw material inspection to final physical and electrical testing of each disk. In addition, by controlling the manufacturing process of both disks and arresters, we achieve the optimal combination. Eaton produces MOV disks of unsurpassed quality through continuous improvements in disk formulation and manufacturing technology. The end result is a long history of in-service use with outstanding durability and protective capability.

Arrester production begins by stacking glass-collared MOV disks in series with aluminum end electrodes. Our proprietary process wraps the assembly with a high-strength woven fiberglass-reinforced epoxy composite. When cured, the arrester module is capable of withstanding high electrical and cantilever load conditions.

The UltraSIL silicone rubber housing utilizes an interference fit and is bonded onto the internal module to form a solid, void-free, high-dielectric strength insulation system. Once the housing is in place, each arrester must pass a strict series of electrical tests to insure the highest level of in-service performance.

The silicone rubber housing results in lighter weight than similarly rated porcelain housed arresters. The silicone rubber housing is also less sensitive to physical damage than porcelain. Also, when compared to other polymeric housing materials, silicone rubber generates significantly lower external power losses under contaminated conditions.

EATON

Powering Business Worldwide

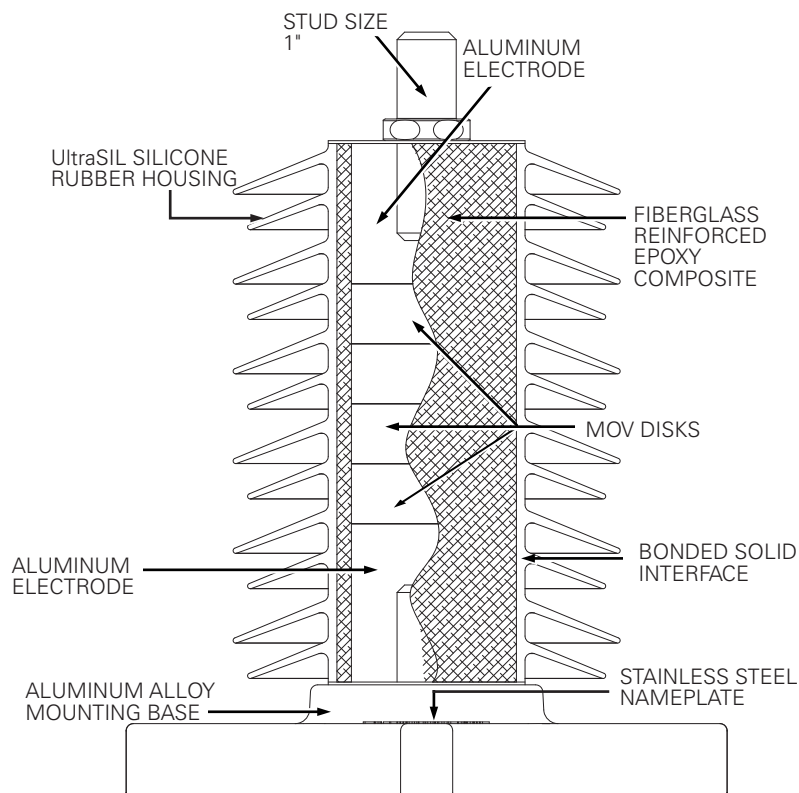

Cutaway illustration of a 10 kV UltraSIL Polymer-Housed VariSTAR Class 3 Arrester.

Table 1. U3 Class 3 Ratings and Characteristics

Arrester Characteristic	Rating	
Arrester Voltage Ratings, U_r	3-240 kV	
Rated Discharge Energy	Single Impulse	Double Impulse*
	kJ/kV of U_c	6.2 9
	kJ/kV of U_r	5.1 7.5
System Frequency (Hz)	50/60	
Nominal Discharge Current (kA)	10	
High Current Withstand, Short Duration Withstand 4/10 μ s (kA)	100	
Short-Circuit/Pressure Relief Rating (kA rms sym.)	63	
Cantilever Strength (Nm)	Ultimate	SLL** SSL***
	2300	920 1150
Ambient Temperature ($^{\circ}$ C)	-40 to +40	
Standard Pollution Level (Creep)	Very Heavy (31 mm/kV)	

* Double impulse rating assumes a two shot energy discharge within one minute.

** Specified Long Term Load

*** Specified Short Term Load

Features

The UltraSIL silicone rubber housing was chosen for its superior insulation performance when compared to other polymeric housing materials. Long term environmental testing has verified the superiority of UltraSIL silicone rubber when compared to other polymeric insulating materials.

Independent laboratory tests have verified the superior water repellent behavior of silicone rubber, which is responsible for the lower external power losses, higher resistance to UV degradation and surface tracking, superior performance in contaminated environments, and other important insulating properties. Also, UltraSIL silicone rubber has been proven not to support biological growth and is non-flammable.

The basic silicone rubber housed arrester can be customized with a variety of terminal and mounting options which allow users to select the features that meet their application needs. The "standard" silicone rubber housing is designed with a minimum specific creepage distance of 31 mm/kV L-L, but if additional creepage is required, please contact your Eaton representative for customized options.

Operation

The operation of the VariSTAR arrester is typical of gapless metal oxide arresters. During steady state conditions, line-to-earth voltage is continuously across the arrester terminals. When overvoltages occur, the VariSTAR arrester immediately limits the overvoltage to the required protective level by conducting only the necessary level of surge current to earth. Upon passage of the overvoltage condition, the arrester returns to its initial condition, once again conducting only minimal leakage current.

UltraSIL polymer-housed VariSTAR Class 3 arresters are ideal for the protection of critical substation apparatus in areas of moderate

lightning incidence and for protection against switching surges generated on transmission systems.

Pressure relief tests have been conducted in accordance with IEC 60099-4 to demonstrate the UltraSIL polymer-housed VariSTAR Class 3 arrester's ability to withstand fault currents for specific durations.

Design testing

The housing material, internal components and hardware work as a system to withstand years of exposure to environmental extremes. To assure a superior level of performance, the components and the assembled arrester unit have been subjected to a testing program that accurately simulates years of exposure to field conditions. Tests include:

IEC 600994 Testing - Full Certification to performance requirements by an independent laboratory has been completed. A certified test report is available upon request.

Additional design verification of the UltraSIL polymer-housed VariSTAR Class 3 arrester includes testing for:

- Ultraviolet withstand
- High voltage dielectric integrity
- Wet arc tracking resistance
- Thermal shock
- Coefficients of expansion and materials compatibility
- Cantilever strength
- Terminal torque

For detailed reports please contact your Eaton sales representative.

Routine tests

A complete automated production test program ensures a quality product. Each metal oxide varistor receives a series of electrical tests. Quality is further demonstrated by tests performed to destruction on samples from every batch of varistors.

Routine tests on the varistor disks performed in accordance with IEC 60099-4:

- 100% Physical inspection
- 100% Discharge voltage test
- 100% Vref at 11 mA
- 100% Watts loss measured at 1.05 x MCOV
- 100% Transmission line discharge energy test
- Batch high-current, short-duration test
- Batch thermal stability test
- Batch aging test

Routine tests on each fully assembled UltraSIL polymer-housed VariSTAR Class 3 arrester, per IEC 60099-4.

- 100% Physical inspection
- 100% Vref test
- 100% Watts loss test
- 100% Partial discharge inception voltage test

General application recommendations

The rating of an arrester is the maximum power-frequency line-to-earth voltage at which the arrester is designed to pass the IEC operating duty test. Table 2 provides a general guide for the selection of the proper arrester for a given system voltage. Eaton's application engineers are available to make specific system application recommendations.

Selection of arrester rating

In arrester rating selection it is preferable to determine the lowest arrester rating that will ensure satisfactory operation. This is the optimum solution because the arrester selected will not only provide the greatest margin of insulation protection but also be the most economical choice.

Increasing arrester ratings above the minimum increases the likelihood of the arrester surviving varying system conditions but compromises the protection of equipment insulation. Table 2 lists VariSTAR U3 arrester ratings commonly used on various three-phase systems.

Rating selection should begin with consideration of the maximum system operating voltage. The maximum power frequency voltage expected under normal system conditions (expressed line-to-earth) should not exceed the selected arrester's continuous operating voltage (Uc).

The temporary overvoltage (TOV) capability of the VariSTAR U3 arrester is shown in Figure 2. The curves indicate the arrester's ability to withstand abnormal system power frequency (sinusoidal) overvoltages for various durations. The values shown assume that the arrester has been energized at COV (Uc) prior to an overvoltage event, that the arrester is in an ambient temperature of 60 °C, and that after the overvoltage durations shown, demonstrate that the arrester will thermally recover when once again energized at COV (Uc).

The voltage withstand capability for application on ungrounded systems after IEC high current duty is 1.076 per unit of COV (Uc) for 24 hours. For ungrounded systems utilizing high impedance or resonant grounding and other systems where the line-to-earth

Table 2. Arrester Ratings Commonly Used on Three-Phase Systems

System Voltages L-L (kV)		Arrester Ratings (kV)	
Nominal	Maximum	Grounded Circuits	High-Impedance/ Ungrounded Circuits
3.3	3.7	3	6
6.6	7.3	6	9
10.0	11.5	9	12-15
11.0	12.0	9-10	
16.4	18.0	15.0	18-21
22.0	24.0	18-21	24-27
33.0	36.3	27-30	36-39
47.0	52.0	39-48	54-60
66.0	72.0	54-60	66-84
91.0	100	78-84	90-96
110	123	96-108	120-135
132	145	108-120	132-144
155	170	132-144	162-172
220	245	180-198	204-240
275	300	216-240	–

voltages exceed this stated TOV capability, arresters having a COV (Uc) equal to line-to line voltage may be required.

For non-sinusoidal transient voltages caused by system switching operations a transient network analyzer (TNA) study is recommended; Eaton's engineers are available to make these studies.

Figure 2 also illustrates the arrester's TOV capabilities with and without prior switching surge duties of up to a maximum capability of 6.2 kJ/ kV of COV (Uc)-single impulse and 9 kJ/kV of COV (Uc)-double impulse.

To assure proper application the following information is normally required:

1. Maximum system operating voltage.
2. System grounding conditions.
 - a. For four-wire circuits, grounding conditions depend upon whether the system is multi-grounded, whether it has neutral impedance, and whether common primary and secondary neutrals are used.
 - b. For three-wire circuits, grounding conditions depend upon whether the system is solidly grounded at the source, grounded through the neutral impedance at the source grounded through transformers, or ungrounded.

Where unusual conditions exist (high ground resistance, high capacitive load, unusual switching surge duty, etc.), the following supplementary information is required:

- Type of unusual condition
- BIL of equipment and separation distance to protected equipment
- Type of construction (phase spacing, length of line, conductor size, etc.)
- Grounding and phase-sequence components of source impedances
- Phase-sequence components of load impedances
- Available fault current
- Potential for loss of neutral earthing during system events

Performance and protective characteristics

Table 4, "Protective Characteristics of the UltraSIL Polymer-Housed Varistor U3 Surge Arrester" displays the Arrester Rating (U_r), Continuous Operating Voltage (U_c) and the guaranteed protective characteristics.

The Steep Current Impulse protective level is the maximum residual voltage for a 10 kA impulse current that crests in one microsecond. Lightning Impulse Residual Voltages represent the maximum protective levels exhibited by the arrester when discharging lightning currents of the standard 8/20 microsecond waveshape. The maximum Switching Impulse Residual Voltages are based on a switching surge current having a time to crest of 30 microseconds. For all ratings the switching surge energy absorption capability is 6.2 kJ/kV of U_c -single impulse and 9 kJ/kV of U_c -double impulse.

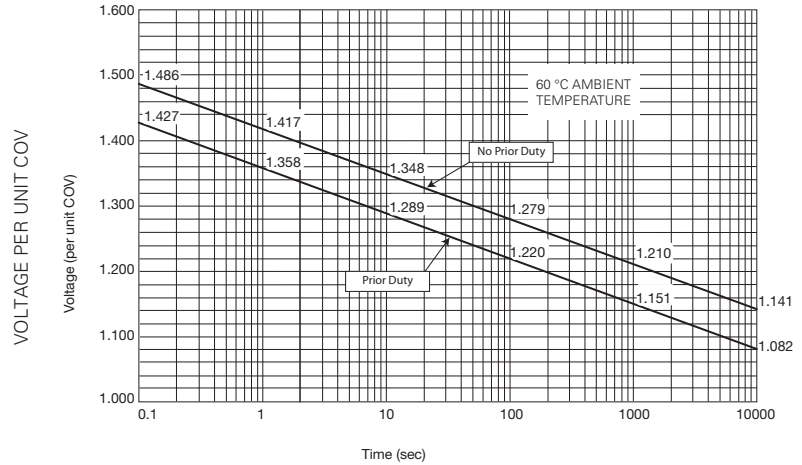

Figure 2. Temporary Overvoltage Capability of VariSTAR U3 Surge Arresters.

Note: The 24-Hour TOV with prior duty is 1.076 per unit of U_c . The TOV curve in Figure 2 applies to standard electrical build arresters. Consult manufacturer for further information regarding alternate electrical builds. See Table 4 for Temporary Over Voltage w/Prior Duty (kV) for 1 and 10 second values.

Table 3. Insulation Withstand Voltages

Housing Designation	Housing Leakage Distance - Creep (mm)	Strike (mm)	Insulation Withstand Voltages			
			BIL 1.2/50 Impulse (kV, Pk)	Switching Surge Impulse (kV, crest)	WET 50/60 Hz 60 Sec (kV, rms)	DRY 50/60 Hz 60 Sec (kV, rms)
08	780	200	119		62	77
10	975	240	137		71	90
12	1170	280	158		83	104
14	1365	319	178		94	118
16	1560	360	201		104	140
18	1755	398	218		122	146
22	2145	477	258		147	166
24	2340	516	279		160	188
26	2535	556	298		172	201
28	2730	594	319		184	215
30	2925	634	340		197	230
32	3120	672	361		208	246
40	3900	875	476		269	312
44	4290	954	516		294	332
46	4485	993	537	N/A	307	354
48	4680	1032	558		320	376
50	4875	1072	577		332	389
52	5070	1112	596		344	402
54	5265	1150	617		356	416
56	5460	1188	638		368	430
58	5655	1228	659		381	445
60	5850	1268	680		394	460
64	6240	1123	631		370	432
72	7020	1359	758		439	505
76	7410	1437	798		463	532
78	7605	1468	809		474	541
80	7800	1506	830		486	555
82	7995	1544	851		498	569
84	8190	1584	872		511	584
86	8385	1622	893	905	522	600
88	8580	1662	914	927	535	615
90	8775	1686	931	929	545	630
92	8970	1730	955	957	557	648
94	9165	1762	973	971	567	662
96	9360	1795	992	984	578	678
A4	10140	2024	1107	1105	646	742
A6	10335	2062	1128	1130	658	756
A8	10335	2062	1128	1130	658	756
B0	10725	2138	1170	1180	682	784
B2	10920	2168	1190	1189	693	801
B4	11115	2208	1211	1211	706	816
B6	11310	2248	1232	1233	719	831
B8	11505	2288	1253	1255	732	846
C0	11700	2320	1271	1269	742	860

Note: Strike and insulation withstand values for housing codes (60+) include a grading ring.

Table 4. Protective Characteristics of the UltraSIL Polymer-Housed VariSTAR U3 Surge Arrester

Arrester Rating Ur (kV, rms)	Arrester COV Uc (kV, rms)	Steep Current Residual Voltage (kV Crest)	Lightning Impulse Residual Voltage (kV Crest) 8/20 μs Current Wave						"Switching Impulse Residual Voltage (kV Crest) 30/60 Current Wave"				Temporary Over Voltage w/Prior Duty (kV)	
			1.5 kA	3 kA	5 kA	10 kA	20 kA	40 kA	125 A	250 A	500 A	1000 A	1 Second	10 Seconds
3	2.55	8.2	6.5	6.9	7.2	7.8	8.4	9.4	5.7	5.9	6.1	6.3	3.5	3.3
6	5.1	16.3	13	13.7	14.3	15.6	16.8	18.8	11.4	11.7	12.1	12.6	6.9	6.6
9	7.65	24.5	19.5	20.6	21.5	23.3	25.2	28.2	17.1	17.6	18.1	18.8	10.4	9.9
10	8.4	26.9	21.4	22.6	23.6	25.6	27.7	30.9	18.8	19.3	19.9	20.7	11.4	10.8
12	10.2	32.6	26	27.4	28.6	31.1	33.6	37.5	22.8	23.4	24.1	25.1	13.9	13.1
15	12.7	40.6	32.4	34.1	35.6	38.7	41.9	46.7	28.4	29.1	30	31.2	17.2	16.4
18	15.3	48.9	39	41.1	42.9	46.6	50.4	56.3	34.2	35.1	36.2	37.6	20.8	19.7
21	17	54.4	43.3	45.6	47.7	51.7	56	62.5	38	39	40.2	41.8	23.1	21.9
24	19.5	62.4	49.7	52.3	54.7	59.3	64.2	71.7	43.6	44.7	46.1	47.9	26.5	25.1
27	22	70.3	56	59	61.7	66.9	72.5	80.9	49.1	50.4	52	54	29.9	28.4
30	24.4	78	62.1	65.5	68.4	74.2	80.4	89.7	54.5	55.9	57.7	59.9	33.1	31.5
33	27.5	87.9	70	73.8	77.1	83.6	90.6	102	61.4	63	65	67.5	37.3	35.4
36	29	92.7	73.8	77.8	81.3	88.2	95.5	107	64.8	66.4	68.6	71.2	39.4	37.4
39	31.5	101	80.2	84.5	88.3	95.8	104	116	70.3	72.2	74.5	77.3	42.8	40.6
42	34	109	86.6	91.2	95.3	104	112	125	75.9	77.9	80.4	83.5	46.2	43.8
45	36.5	117	92.9	97.9	103	111	121	135	81.5	83.6	86.3	89.6	49.6	47
48	39	125	99.3	105	110	119	129	144	87.1	89.3	92.2	95.7	53	50.3
54	42	135	107	113	118	128	139	155	93.8	96.2	99.3	104	57	54.1
60	48	154	123	129	135	146	159	177	108	110	114	118	65.2	61.9
66	53	170	135	143	149	162	175	195	119	122	126	131	72	68.3
72	57	183	146	153	160	174	188	210	128	131	135	140	77.4	73.5
78	62	199	158	167	174	189	205	228	139	142	147	153	84.2	79.9
84	68	218	174	183	191	207	224	250	152	156	161	167	92.3	87.7
90	72	231	184	194	202	219	238	265	161	165	171	177	97.8	92.8
96	76	243	194	204	214	232	251	280	170	174	180	187	103.2	98
	77	247	196	207	216	235	254	284	172	177	182	189	104.6	99.3
108	84	269	214	226	236	256	277	309	188	193	199	207	114.1	108.3
120	98	314	250	263	275	298	323	361	219	225	232	241	133.1	126.3
132	106	339	270	285	298	323	349	390	237	243	251	261	143.9	136.6
138	111	355	283	298	312	338	366	408	248	255	263	273	150.7	143.1
144	115	368	293	309	323	350	379	423	257	264	272	283	156.2	148.2
150	120	384	306	322	337	365	396	442	268	275	284	295	163	154.7
162	130	416	331	349	365	396	429	478	291	298	308	319	176.5	167.6
168	131	419	334	352	368	399	432	482	293	300	310	322	177.9	168.9
172	140	448	357	376	393	426	461	515	313	321	331	344	190.1	180.5
180	144	461	367	387	404	438	475	530	322	330	341	354	195.6	185.6
192	152	486	387	408	427	463	501	559	340	348	360	373	206.4	195.9
198	160	512	408	430	449	487	527	589	358	367	378	393	217.3	206.2
204	165	528	420	443	463	502	544	607	369	378	390	405	224.1	212.7
216	174	556	443	467	488	529	573	640	389	399	412	427	236.3	224.3
228	180	576	459	483	505	548	593	662	402	413	426	442	244.4	232
240	190	608	484	510	533	578	626	699	424	435	449	467	258	244.9

Dimensions and mounting

Figure 3 illustrates an in-line mounting arrangement; the applicable values of "B" and "C" may be found in Table 5. Line and Earth terminal details are shown on pages 10-11, options 14 and 15. Figure 4 shows an outline drawing of the standard U3 UltraSIL polymer-housed VariSTAR Class 3 arrester. The values for dimensions "A" and "D" for all ratings are listed in Table 5.

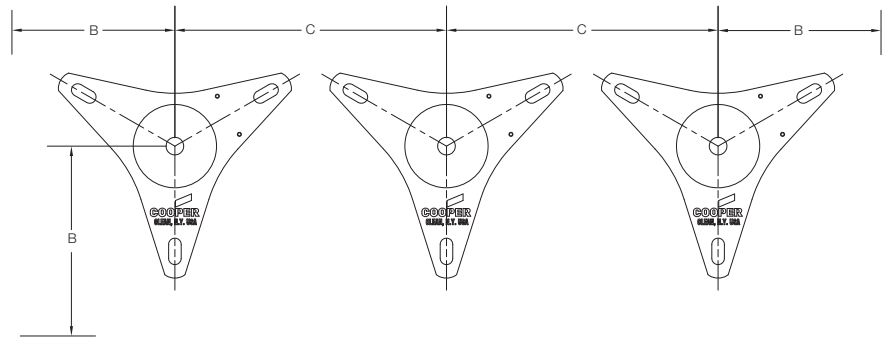

Three-phase in-line mounting.

Note: Refer to Table 5 for Dimensions B and C.

Table 5. Catalog Numbers, Dimensional Information, and Weights for VariSTAR U3 Surge Arresters¹

Arrester Rating Ur (kV, rms)	Arrester COV Uc (kV, rms)	Standard Arrester Catalog Number	Dim. A (mm)	Dim. D (mm)	Dimension B Minimum Phase-to-Earth Clearance* (mm)	Dimension C Minimum Phase-to-Phase Clearance* (mm)	Housing Leakage Distance (mm)	Arrester Mass (kg)
			Reference Figure 4		Reference Figure 3			
3	2.55	U3AA003002A0845AAA	208	139	140	254	780	5
6	5.1	U3AA006005A1045AAA	247		143	258	975	
9	7.65	U3AA009007A1045AAA			147	261		
10	8.4	U3AA010008A1045AAA			287	158		272
12	10.2	U3AA012010A1245AAA	176			290		
15	12.7	U3AA015012A1245AAA	198			312	1365	
18	15.3	U3AA018015A1445AAA	218		332			
21	17	U3AA021017A1445AAA	366		239	353		1560
24	19.5	U3AA024019A1645AAA			260	374		
27	22	U3AA027022A1645AAA			287	401	1755	
30	24.4	U3AA030024A1845AAA	300		415			
33	27.5	U3AA033027A1845AAA	322		436	2145		
36	29	U3AA036029A1845AAA	344		458			
39	31.5	U3AA039031A2245AAA	366		480		2340	
42	34	U3AA042034A2245AAA	388		502			
45	36.5	U3AA045036A2445AAA	414		528	2535		
48	39	U3AA048039A2645AAA	467		581		2730	
54	42	U3AA054042A2645AAA	510		625			2925
60	48	U3AA060048A2845AAA	546		660	3120		
66	53	U3AA066053A3045AAA	589		704		3900	
72	57	U3AA072057A3245AAA	642		756			4290
78	62	U3AA078062A4045AAA	677		791	4485		
84	68	U3AA084068A4445AAA	712		826		4680	
90	72	U3AA090072A4645AAA	721		835			4875
96	76	U3AA096076A4845AAA	782		896	5070		
96	77	U3AA096077A5045AAA	905		1019		5460	
108	84	U3AA108084A5245AAA	1191		1521			5850
120	98	U3AA120098A5645AAA	1234		1565	6240		
132	106	U3AA132106A6045AAA	1269		1600		7605	
138	111	U3AA138111A6445AAA	1313		1643			7800
144	115	U3AA144115A6445AAA	1401		1731	7995		
150	120	U3AA150120A7845AAA	1410		1740		8190	
162	130	U3AA162130A8045AAA	1488		1819			8385
168	131	U3AA168131A8245AAA	1523		1854	8580		
172	140	U3AA172140A8445AAA	1594		1924		8970	
180	144	U3AA180144A8645AAA	1664		1994			9165
192	152	U3AA192152A8845AAA	1707	2038	10335			
198	160	U3AA198160A9245AAA	1786	2116		10725		
204	165	U3AA204165A9445AAA	1839	2169			10920	
216	174	U3AA216174AA645AAA	1926	2257	1170			
228	180	U3AA228180AB045AAA	1926	2257		1365		
240	190	U3AA240190AB245AAA	1926	2257			1560	
					1755			
						2145		
							2340	
					2535			
						2730		
							2925	
					3120			
						3900		
							4290	
					4485			
						4680		
							4875	
					5070			
						5460		
							5850	
					6240			
						7605		
							7800	
					7995			
						8190		
							8385	
					8580			
						8970		
							9165	
					10335			
						10725		
							10920	
					1365			
						1560		
							1755	
					2145			
						2340		
							2535	
					2730			
						2925		
							3120	
					3900			
						4290		
							4485	
					4680			
						4875		
							5070	
					5460			
						5850		
							6240	
					7605			
						7800		
							7995	
					8190			
						8385		
							8580	
					8970			
						9165		
							10335	
					10725			
						10920		
							1365	
					1560			
						1755		
							2145	
					2340			
						2535		
							2730	
					2925			
						3120		
							3900	
					4290			
						4485		
							4680	
					4875			
						5070		
							5460	
					5850			
						6240		
							7605	
					7800			
						7995		
							8190	
					8385			
						8580		
							8970	
					9165			
						10335		
							10725	
					10920			
						1365		
							1560	
					1755			
						2145		
							2340	
					2535			
						2730		
							2925	
					3120			
						3900		
							4290	
					4485			
						4680		
							4875	
					5070			
						5460		
							5850	
					6240			
						7605		
							7800	
					7995			
						8190		
							8385	
					8580			
						8970		
							9165	
					10335			
						10725		
							10920	
					1365			
						1560		
							1755	
					2145			
						2340		
							2535	
					2730			
						2925		
							3120	
					3900			
						4290		
							4485	
					4680			
						4875		
							5070	
					5460			
						5850		
							6240	
					7605			
						7800		
							7995	
					8190			
						8385		
							8580	
					8970			
						9165		
							10335	
					10725			
						10920		
							1365	
					1560			
						1755		
							2145	
					2340			
						2535		
							2730	
					2925			
						3120		
							3900	
					4290			
						4485		
							4680	
					4875			
						5070		
							5460	
					5850			
						6240		
							7605	
					7800			
						7995		
							8190	
					8385			
						8580		
							8970	
					9165			
						10335		
							10725	
					10920			
						1365		
							1560	
					1755			
						2145		
							2340	
					2535			
						2730		
							2925	
					3120			
						3900		
							4290	
					4485			
						4680		
							4875	
					5070			
						5460		
							5850	
					6240			
						7605		
							7800	
					7995			
						8190		
							8385	
					8580			
						8970		
							9165	
					10335			
						10725		
							10920	
					1365			
						1560		
							1755	
					2145			
						2340		
							2535	
					2730			
						2925		
							3120	
					3900			
						4290		
							4485	
					4680			
						4875		
							5070	
					5460			
						5850		
							6240	
					7605			
						7800		
							7995	
					8190			
						8385		
							8580	
					8970			
						9165		
							10335	
					10725			
						10920		
							1365	
					1560			
						1755		
							2145	
					2340			
						2535		
							2730	
					2925			
						3120		
							3900	
					4290			
						4485		
							4680	
					4875			
						5070		
				</				

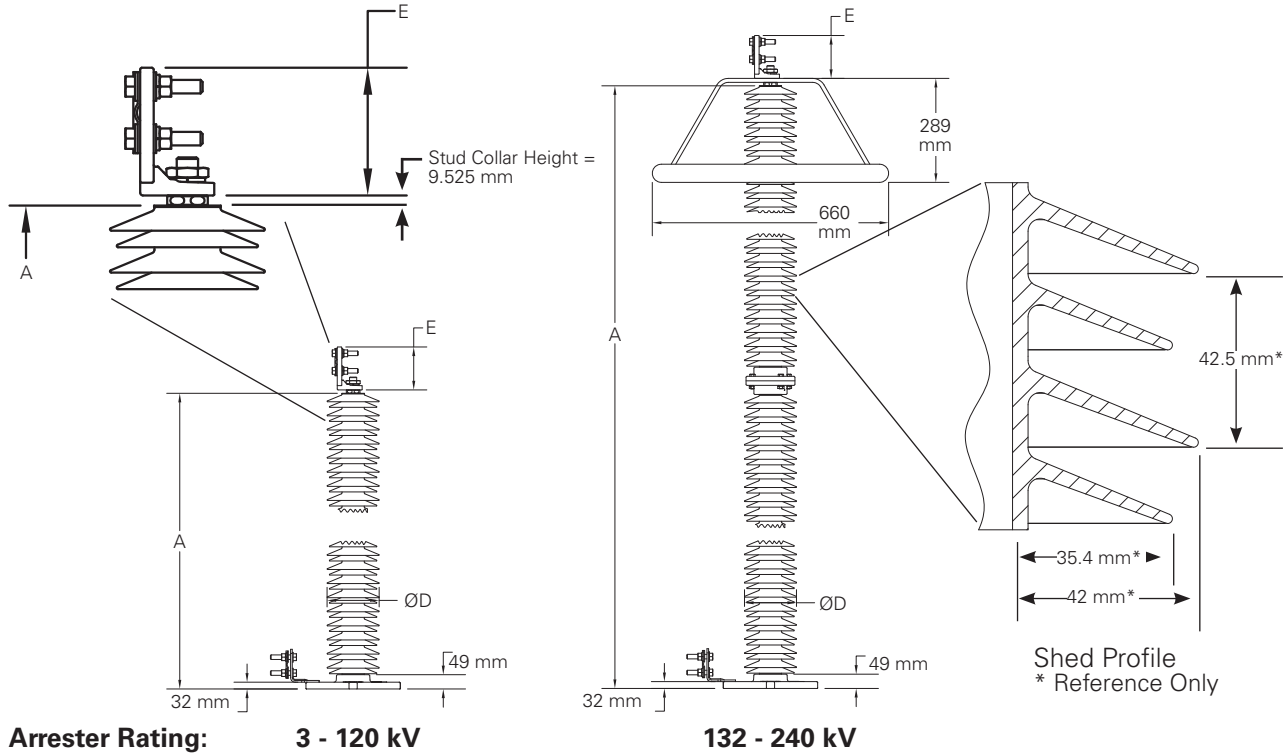

Figure 4. Outline Drawing of Standard UltraSIL Polymer-Housed VariSTAR Type U3 Surge Arresters.

Notes:

Refer to Table 5 for dimensions A. Arresters shown with standard line and earth terminals.

Outlines in Figure 4 and data from Table 5 represent standard arrester catalog numbers. Outline dimensions will vary when optional housing codes are selected. Consult factory for more information.

Refer to Table 6 for dimensions E.

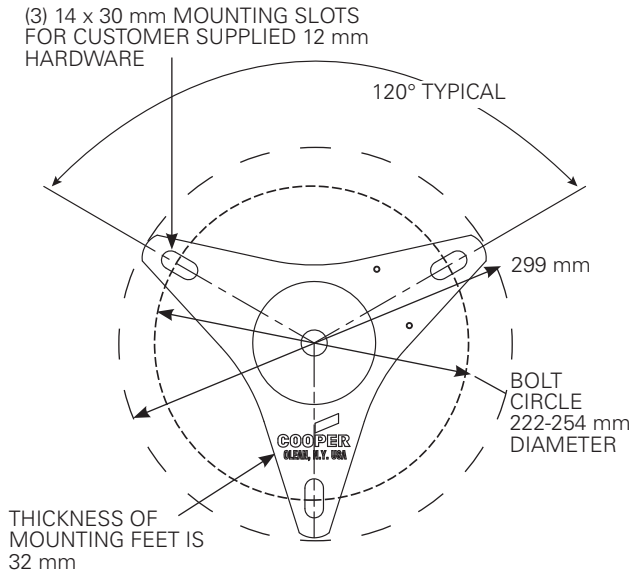

Figure 5. Base mounting.

Terminal option dimensions

Table 6. Terminal Options Dimensions "E"

Catalog Number Digit 14	Description of Line Terminal Option	Dimension (mm)
1	Eyebolt Connector	81
4	NEMA Four-Hole Pad	120
D, H	Cylindrical Stem Connector	156

Note: Refer to Figure 4 for illustration of dimension E.

Isolation bases and surge counters

Table 7. Bases and Counters

Catalog Number	Description of Counters
AM22A1	Counter without Leakage Current Meter
AM22A2	Counter with Leakage Current Meter (0-30 mA)
AM22A3	Counter with Leakage Current Meter (0-50 mA)
AM22A12	AM22A2 with Auxiliary Contact
Description of Bases	
AM23A1	For U2, U3, and U4 arresters rated 120 kV (single section) or below

Table 8. UltraQUIK™ Catalog Numbering System for UltraSIL Polymer-Housed VariSTAR Class 3 Arresters

1 U	2 3	3	4	5	6	7	8	9	10	11	12	13	14	15	16	17	18
---------------	---------------	---	---	---	---	---	---	---	----	----	----	----	----	----	----	----	----

Catalog Number Digits:

1 = "U" (UltraSIL Housed Arrester)

2 = "3" (IEC Class 3 Arrester)

3 = "A" Standard Electrical Build*

* Consult manufacturer for further information regarding alternate electrical builds.

4 = "A" Standard Cantilever Strength Design

5 through 10 = Arrester Rating, U_r (COV, U_c)

003002 = 3 kV (2.55 kV)	042034 = 42 kV (34.0 kV)	132106 = 132 kV (106 kV)
006005 = 6 kV (5.10 kV)	045036 = 45 kV (36.5 kV)	138111 = 138 kV (111 kV)
009007 = 9 kV (7.65 kV)	048039 = 48 kV (39.0 kV)	144115 = 144 kV (115 kV)
010008 = 10 kV (8.4 kV)	054042 = 54 kV (42.0 kV)	150120 = 150 kV (120 kV)
012010 = 12 kV (10.2 kV)	060048 = 60 kV (48.0 kV)	162130 = 162 kV (130 kV)
015012 = 15 kV (12.7 kV)	066053 = 66 kV (53.0 kV)	168131 = 168 kV (131 kV)
018015 = 18 kV (15.3 kV)	072057 = 72 kV (57.0 kV)	172140 = 172 kV (140 kV)
021017 = 21 kV (17.0 kV)	078062 = 78 kV (62.0 kV)	180144 = 180 kV (144 kV)
024019 = 24 kV (19.5 kV)	084068 = 84 kV (68.0 kV)	192152 = 192 kV (152 kV)
027022 = 27 kV (22.0 kV)	090070 = 90 kV (70.0 kV)	198160 = 198 kV (160 kV)
030024 = 30 kV (24.4 kV)	096076 = 96 kV (76.0 kV)	204165 = 204 kV (165 kV)
033027 = 33 kV (27.0 kV)	096077 = 96 kV (77.0 kV)	216174 = 215 kV (174 kV)
036029 = 36 kV (29.0 kV)	108084 = 108 kV (84.0 kV)	228182 = 228 kV (182 kV)
039031 = 39 kV (31.5 kV)	120098 = 120 kV (98.0 kV)	240190 = 240 kV (190 kV)

11 = "A" High Creep UltraSIL Polymer Housing

Table 8. UltraQUIK™ Catalog Numbering System for UltraSIL Polymer-Housed VariSTAR Class 3 Arresters (continued)

1 U	2 3	3	4	5	6	7	8	9	10	11	12	13	14	15	16	17	18
---------------	---------------	---	---	---	---	---	---	---	----	----	----	----	----	----	----	----	----

12 and 13 = Housing Code (Select from Table below): O = Standard Housing (31 mm/kV)

Leakage Length (mm) U _r Arrester Rating (kV rms)	08	10	12	14	16	18	22	24	26	28	30	32	40	44	46	48	50	52	56	60*	64*	78*	80*	82*	84*	86*	88*	92*	94*	A6*	B0*	B2*				
	780	975	1171	1365	1560	1755	2145	2340	2535	2730	2925	3120	3900	4290	4485	4680	4875	5070	5460	5850	6240	7605	7800	7995	8190	8385	8580	8970	9165	10335	10725	10920				
3	O																																			
6		O																																		
9		O																																		
10		O																																		
12			O																																	
15			O																																	
18				O																																
21				O																																
24					O																															
27					O																															
30						O																														
33						O																														
36						O																														
39							O																													
42							O																													
45								O																												
48									O																											
54										O																										
60											O																									
66												O																								
72													O																							
78														O																						
84															O																					
90																O																				
96																	O	O																		
108																		O																		
120																			O																	
132																				O																
138																					O															
144																						O														
150																							O													
162																								O												
168																									O											
172																										O										
180																											O									
192																												O								
198																													O							
204																														O						
216																															O					
228																																O				
240																																				O

* Arresters equipped with these housing codes ship with a grading ring.

Table 8. Ultraquik Catalog Numbering System for UltraSIL Polymer-Housed VariSTAR Class 3 Arresters (continued)

1	U	2	3	3	4	5	6	7	8	9	10	11	12	13	14	15	16	17	18
---	---	---	---	---	---	---	---	---	---	---	----	----	----	----	----	----	----	----	----

14 = Line Terminal Options

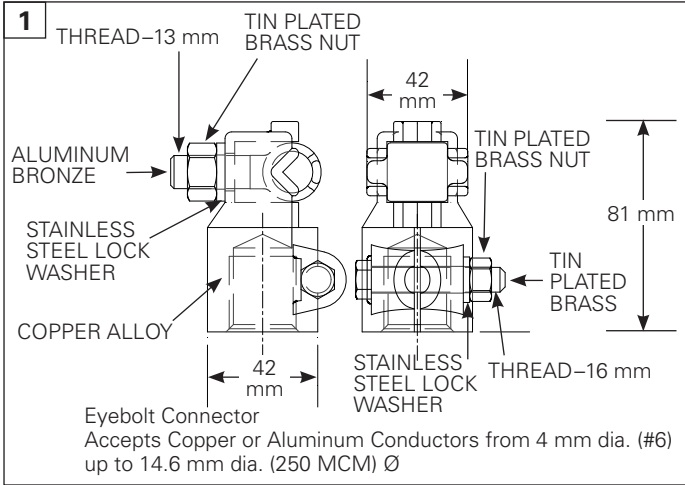

D or H

D =
100 mm X
30 mm Ø
Aluminum Cylindrical Stem
Connector

H =
Same as D but with 26 mm Ø

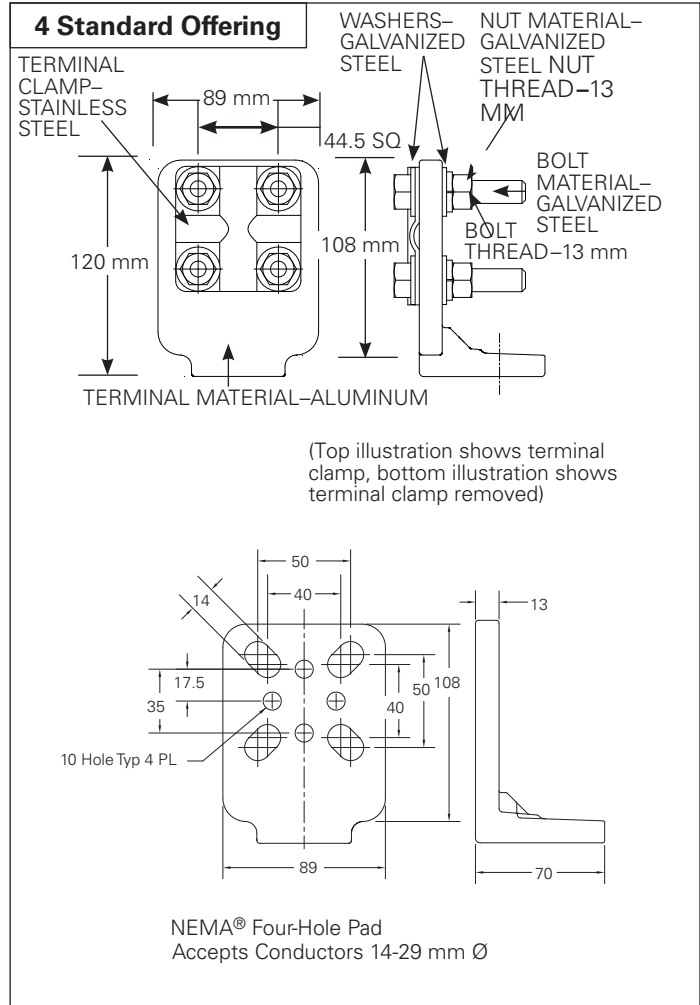
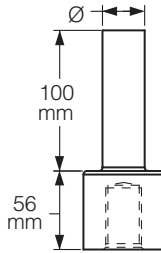
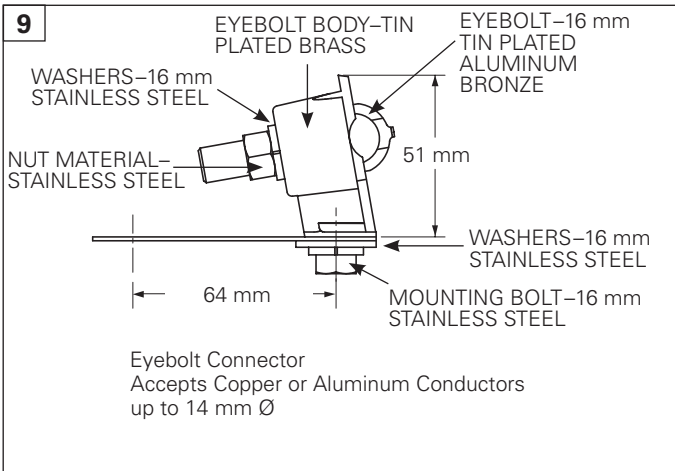
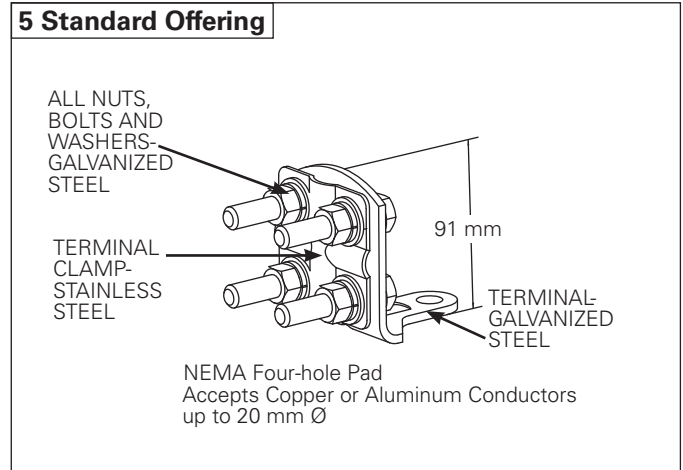
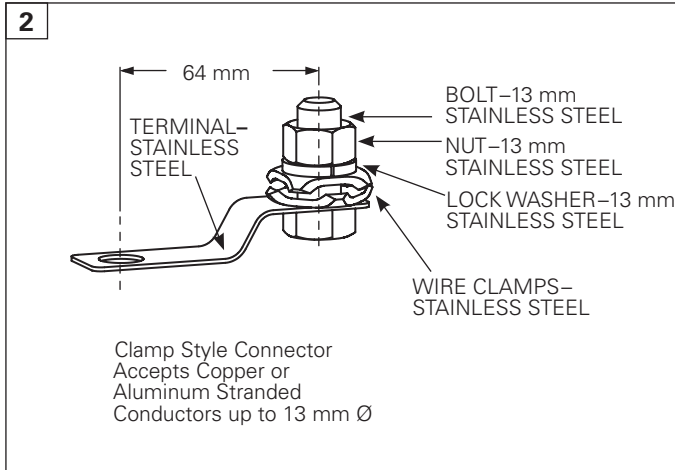

Table 8. UltraQUIK Catalog Numbering System for UltraSIL Polymer-Housed VariSTAR Class 3 Arresters (continued)

1	U	2	3	3	4	5	6	7	8	9	10	11	12	13	14	15	16	17	18
---	---	---	---	---	---	---	---	---	---	---	----	----	----	----	----	----	----	----	----

15 = Earth Terminal Options



16 = Mounting Arrangement

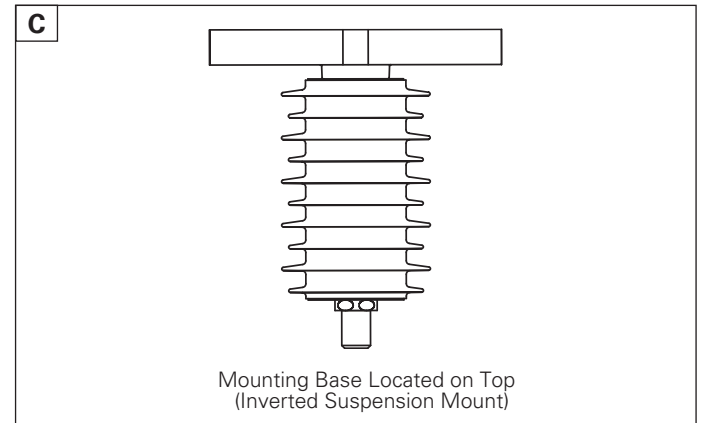
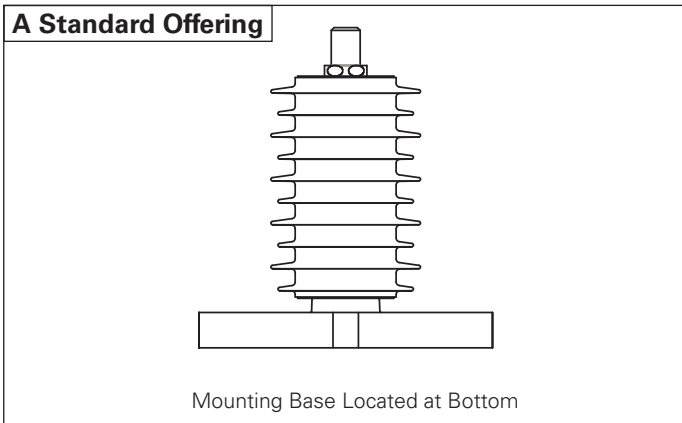

Table 8. UltraQUIK Catalog Numbering System for UltraSIL Polymer-Housed VariSTAR Class 3 Arresters (continued)

1	2	3	4	5	6	7	8	9	10	11	12	13	14	15	16	17	18
U	3																

17 = Nameplate Information, See Figures 6 and 7

Nameplate information is per IEC 60099-4 and is available in the following languages.

Specify:

A = English **B** = Spanish **C** = Portuguese

18 = Packaging

Arresters with housing codes 60 or less are shipped complete, ready for installation. Arresters with housing codes greater than 60 are shipped unassembled, requiring assembly during installation.

A = Export packing, cardboard
2 = Export packing, wood crating

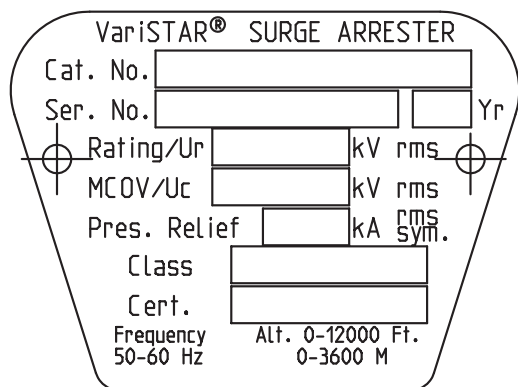

Figure 6. Arrester base nameplate (English version).

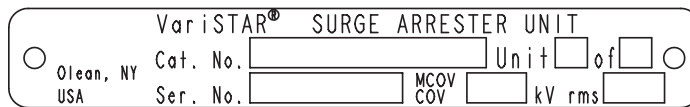

Figure 7. Detail of unit nameplate on arrester base.

Nameplate information

A stainless steel nameplate is attached to the base of every UltraSIL polymer-housed Type U3 arrester. The arrester catalog number, serial number, year of manufacture, Ur, Uc, and pressure relief rating are among the details provided on the nameplate. See Figure 6 for an example of a base nameplate. For multi-unit arresters an additional nameplate is provided on the base as shown in Figure 7.

Additional information

- IS235-97-1 UltraSIL Polymer-Housed VariSTAR Type U3/U4 Surge Arrester Installation and Maintenance Instructions
- CP1219 10 kA Class 3 Certified Test Report IEC 60099-4 2009
- CA235024EN UltraSIL Polymer-Housed VariSTAR Type U4 Surge Arrester for Systems through 275 kV IEC 20-kA; Line Discharge Class 4
- CP1302 20 kA Class 4 Certified Test Report IEC 60099-4 2009

Eaton
1000 Eaton Boulevard
Cleveland, OH 44122
United States
Eaton.com

Eaton's Power Systems Division
2300 Badger Drive
Waukesha, WI 53188
United States
Eaton.com/cooperpowerseries

© 2016 Eaton
All Rights Reserved
Printed in USA
Publication No. CA235034EN

Eaton is a registered trademark.

All trademarks are property of their respective owners.

For Eaton's Cooper Power series product information call 1-877-277-4636 or visit: www.eaton.com/cooperpowerseries.