

UltraSIL Polymer-Housed VariSTAR Type U2 Surge Arrester for Systems through 275 kV IEC 10-kA; Line Discharge Class 2



Figure 1.
UltraSIL Polymer-Housed VariSTAR Class 2 Surge Arrester family.

EATON

Powering Business Worldwide

General

Eaton's Cooper Power series UltraSIL™ Polymer-Housed VariSTAR™ Type U2 Surge Arresters offer the latest in metal oxide varistor (MOV) technology for the economical protection of medium-voltage class power and substation equipment. These arresters are gapless and are constructed of a single series column of 51 mm diameter MOV disks. The arrester is designed and tested to the requirements of the International Electrotechnical Commission Standard IEC 60099-4, and is available in ratings suitable for the transient overvoltage protection of electrical equipment on systems through 275 kV.

The UltraSIL Polymer-Housed U2 Surge Arrester incorporates the industry recognized superior polymeric material—Silicone Rubber.

The advantages of polymer-housed arresters—reduced size and weight and enhanced safety—have been refined in this next generation Cooper Power series UltraSIL Polymer-Housed U2 Surge Arrester from Eaton.

Table 1. UltraSIL Housed Type U2 Class 2 Ratings and Characteristics

Arrester Characteristic	Rating		
Arrester Voltage Ratings, Ur	3-240 kV		
Rated Discharge Energy	Single Impulse	Double Impulse*	
	kJ/kV of Uc	3.4	5.3
	kJ/kV of Ur	2.7	4.2
System Frequency (Hz)	50/60		
Classifying Current (kA)	10		
High Current Withstand** (kA)	100		
Pressure Relief Rating (kA rms sym.)	3-108 kV	40	
	120-240 kV	63	
Cantilever Strength (Nm)	Ultimate	MPSL (Static)***	
	U2 (3-108 kV)	1,150	460
	U2 (120-240 kV)	1,700	680

* Double impulse rating assumes a two shot energy discharge within one minute.

** High current, short duration withstand (100 kA, 4/10 μ s)

*** MPSL—Maximum permissible service load (static) or maximum working load is 40% of the ultimate.

Construction

The unique construction of UltraSIL Polymer-Housed Class 2 Arresters begins with world class Metal Oxide Varistor (MOV) disks produced at our manufacturing facility in Olean, NY. By manufacturing our own disks we maintain a strict quality control over the entire production process, from initial raw material inspection to final physical and electrical testing of each disk. In addition, by controlling the manufacturing process of both disks and arresters, we achieve the optimal combination. Eaton produces MOV disks of unsurpassed quality through continuous improvements in disk formulation and manufacturing technology. The end result is a long history of in-service use with outstanding durability and protective capability.

Arrester production begins by stacking glass-collared MOV disks in series with aluminum end electrodes. Our proprietary process wraps the assembly with a high-strength woven fiberglass-reinforced epoxy composite. When cured, the arrester module is capable of withstanding high electrical and cantilever load conditions.

The UltraSIL silicone rubber housing utilizes an interference fit and is bonded onto the internal module to form a solid, void-free, high-dielectric strength insulation system. Once the housing is in place, each arrester must pass a strict series of electrical tests to insure the highest level of in-service performance.

The silicone rubber housing results in lighter weight than similarly rated porcelain housed arresters. The silicone rubber housing is also less sensitive to physical damage than porcelain. Also, when compared to other polymeric housing materials, silicone rubber generates significantly lower external power losses under contaminated conditions.

Features

The UltraSIL silicone rubber housing was chosen for its superior insulation performance when compared to other polymeric housing materials. Long term environmental testing has verified the superiority of UltraSIL silicone rubber when compared to other polymeric insulating materials.

Independent laboratory tests have verified the superior water repellent behavior of silicone rubber, which is responsible for the lower external power losses, higher resistance to UV degradation and surface tracking, superior performance in contaminated environments, and other important insulating properties. Also, UltraSIL silicone rubber has been proven not to support biological growth and is nonflammable.

The basic silicone rubber housed arrester can be customized with a variety of terminal and mounting options which allow users to select the features that meet their application needs. Customers who require longer creepage housings can easily select a different housing option through the catalog numbering system. See pages 7-10 for a complete list of available options.

Operation

The operation of the VariSTAR arrester is typical of gapless metal oxide arresters. During steady state conditions, line-to-earth voltage is continuously across the arrester terminals. When overvoltages occur, the VariSTAR arrester immediately limits the overvoltage to the required protective level by conducting only the necessary level of surge current to earth. Upon passage of the overvoltage condition, the arrester returns to its initial condition, once again conducting only minimal leakage current.

UltraSIL Polymer-Housed VariSTAR Class 2 Arresters are ideal for the protection of critical substation apparatus in areas of moderate lightning incidence and for protection against

switching surges generated on transmission systems. Pressure relief tests have been conducted in accordance with IEC 60099-4 to demonstrate the UltraSIL Polymer-Housed VariSTAR Class 2 Arrester's ability to withstand fault currents for specific durations.

Design testing

The housing material, internal components and hardware work as a system to withstand years of exposure to environmental extremes. To assure a superior level of performance, the components and the assembled arrester unit have been subjected to a testing program that accurately simulates years of exposure to field conditions. Tests include:

IEC 600994 testing - full certification to performance requirements by an independent laboratory has been completed. A certified test report is available upon request.

Additional design verification of the UltraSIL Housed VariSTAR Class 2 Arrester includes testing for:

- Ultraviolet withstand
- High voltage dielectric integrity
- Wet arc tracking resistance
- Thermal shock
- Coefficients of expansion and materials compatibility
- Cantilever strength
- Terminal torque

For detailed reports please contact your Eaton sales representative.

Routine tests

A complete automated production test program ensures a quality product. Each metal oxide varistor receives a series of electrical tests. Quality is further demonstrated by tests performed to destruction on samples from every batch of varistors.

Figure 2. Cutaway illustration of UltraSIL Polymer-Housed VariSTAR Class 2 Arrester.

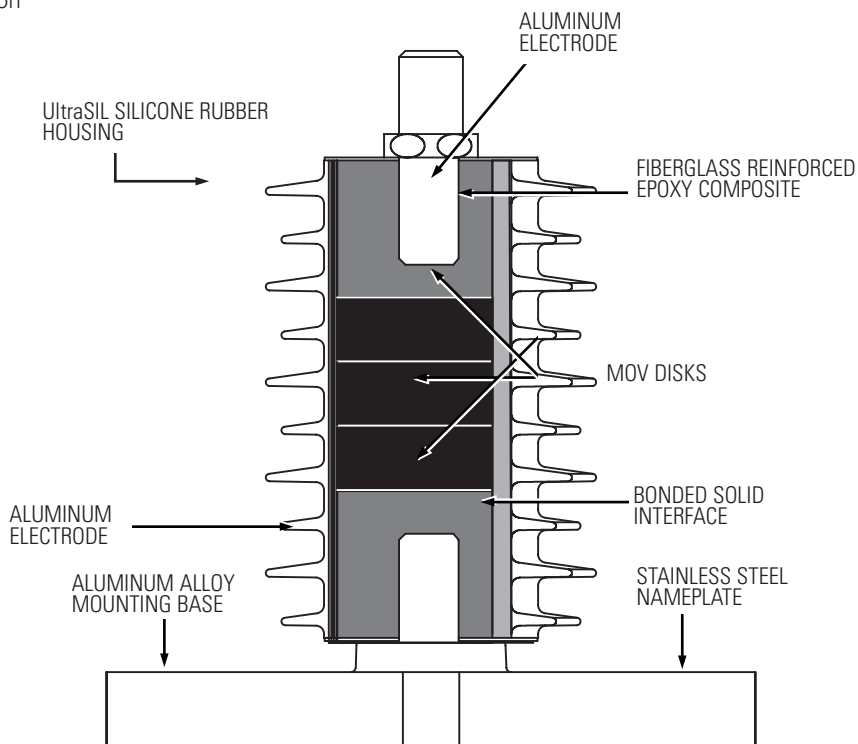

Routine tests on the varistor disks performed in accordance with IEC 60099-4:

- Physical inspection
- Residual voltage test
- V_{ref} at 6 mA
- Watts loss at $1.05 \times U_C$
- Measured at ambient temp.
- Transmission line discharge
- Energy test
- Batch high-current, short-duration
- Batch thermal stability test
- Batch aging test

Routine tests on each fully assembled UltraSIL Polymer-Housed VariSTAR Class 2 Arrester, per IEC 60099-4.

- Physical inspection
- Partial discharge test
- Reference voltage test
- Watts loss test

General application recommendations

The rating of an arrester is the maximum power-frequency line-to-earth voltage at which the arrester is designed to pass the IEC operating duty test. Table 2 provides a general guide for the selection of the proper arrester for a given system voltage. Eaton application engineers are available to make specific system application recommendations.

Selection of arrester rating

In arrester rating selection it is preferable to determine the lowest arrester rating that will ensure satisfactory operation. This is the optimum solution because the arrester selected will not only provide the greatest margin of insulation protection but also be the most economical choice.

Increasing arrester ratings above the minimum increases the likelihood of the arrester surviving varying system conditions but compromises the protection of equipment insulation. Table 2 lists VariSTAR U2 arrester ratings commonly used on various three-phase systems.

Rating selection should begin with consideration of the maximum system operating voltage. The maximum power frequency voltage expected under normal system conditions (expressed line-to-earth) should not exceed the selected arrester's continuous operating voltage (U_C).

The temporary overvoltage (TOV) capability of the VariSTAR U2 arrester is shown in Figure 3. The curves indicate the arrester's ability to withstand abnormal system power frequency (sinusoidal) overvoltages for various durations. The values shown assume that the arrester has been energized at COV (U_C) prior to an overvoltage event, that the arrester is in an ambient temperature of 60° C, and that after the overvoltage durations shown, demonstrate that the arrester will thermally recover when once again energized at COV (U_C).

The voltage withstand capability for application on ungrounded systems after IEC high current duty is 1.07 per unit of COV (U_C) for 24 hours. For ungrounded systems utilizing high impedance or resonant grounding and other systems where the line-to-earth voltages exceed this stated TOV capability, arresters having a COV (U_C) equal to line-to-line voltage may be required.

For non-sinusoidal transient voltages caused by system switching operations a transient network analyzer (TNA) study is recommended; Eaton's engineers are available to make these studies. Figure 3 also illustrates the arrester's TOV capabilities with and without prior switching surge duties of up to a maximum capability of 3.4 kJ/ kV of COV (U_C)-single impulse and 5.3 kJ/kV of COV (U_C)-double impulse.

Table 2. Arrester ratings commonly used on 3-phase systems

System Voltages L-L (kV)		Arrester Ratings (kV)	
Nominal	Max	Grounded Circuits	High-Impedance/ Ungrounded Circuits
3.3	3.7	3	6
6.6	7.3	6	9
10.0	11.5	9	12-15
11.0	12.0	9-10	12-15
16.4	18.0	15.0	18-21
22.0	24.0	18-21	24-27
33.0	36.3	27-30	36-39
47.0	52.0	39-48	54-60
66.0	72.0	54-60	66-84
91.0	100	78-84	90-96
110	123	96-108	120-135
132	145	108-120	132-144
155	170	132-144	162-172
220	245	180-198	204-240
275	300	216-240	-

Figure 3. Temporary Overvoltage Capability of VariSTAR U2 Surge Arresters.

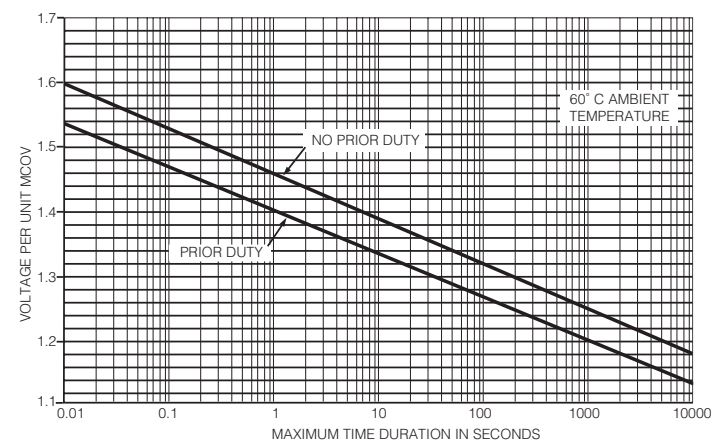

Note: The 24 hour TOV with prior duty is 1.07 per unit of U_C .

To assure proper application the following information is normally required:

1. Maximum system operating voltage.
2. System grounding conditions.
 - A. For four-wire circuits, grounding conditions depend upon whether the system is multi-grounded, whether it has neutral impedance, and whether common primary and secondary neutrals are used.
 - B. For three-wire circuits, grounding conditions depend upon whether the system is solidly grounded at the source, grounded through the neutral impedance at the source grounded through transformers, or ungrounded.

Where unusual conditions exist (high ground resistance, high capacitive load, unusual switching surge duty, etc.), the following supplementary information is required:

- Type of unusual condition
- BIL of equipment and separation distance to protected equipment
- Type of construction (phase spacing, length of line, conductor size, etc.)
- Grounding and phase-sequence components of source impedances
- Phase-sequence components of load impedances
- Available fault current
- Potential for loss of neutral earthing during system events

Performance and protective characteristics

Table 4, "Protective Characteristics of the UltraSIL Polymer-Housed Varistar U2 Surge Arrester" displays the Arrester Rating (U_p), Continuous Operating Voltage (U_c) and the guaranteed protective characteristics. The Steep Current Impulse protective level is the maximum residual voltage for a 10 kA impulse current that crests in one microsecond. Lightning Impulse Residual Voltages represent the maximum protective levels exhibited by the arrester when discharging lightning currents of the standard 8/20 microsecond waveshape. The maximum Switching Impulse Residual Voltages are based on a switching surge current having a time to crest of 30 microseconds. For all ratings the switching surge energy absorption capability is 3.4 kJ/kV of U_c -single impulse and 5.3 kJ/kV of U_c -double impulse.

Table 3. Insulation Withstand Voltages

Housing Designation	Housing Leakage Distance (mm)	Strike (mm)	Insulation Withstand Voltages		
			BIL 1.2/50 Impulse (kV, Pk)	Switching Surge Impulse (kV, crest)	Wet 50/60 Hz 60 Sec (kV, rms)
6	324	157	105	0	42
8	445	196	130	0	53
10	556	235	149	0	65
12	668	275	171	0	77
14	779	314	193	0	89
18	1001	393	236	0	113
20	1113	433	255	0	121
22	1224	472	279	0	137
24	1335	512	301	0	149
26	1446	551	322	0	161
28	1558	590	344	0	173
30	1669	630	366	0	185
36	2003	783	472	0	226
38	2114	822	491	0	234
40	2225	862	510	0	242
42	2336	901	534	0	258
44	2448	940	558	0	274
48	2670	1019	602	0	298
50	2781	1059	623	0	310
52	2893	1098	644	0	322
54	3004	1138	666	0	334
56	3115	1177	688	0	346
58	3226	1217	710	0	358
60	3338	1256	732	0	370
72	4005	1347	823	0	411
74	4116	1387	844	0	423
76	4228	1426	865	0	435
78	4339	1451	884	0	441
80	4450	1491	906	0	453
82	4561	1530	928	0	465
84	4673	1557	957	0	478
86	4784	1596	979	0	490
88	4895	1636	1001	0	502
90	5006	1665	1029	961	523
92	5118	1794	1083	1033	548
94	5229	1834	1105	1054	560
96	5340	1855	1124	1069	560
98	5451	1895	1145	1090	572
A0	5563	1934	1166	1111	584
A4	5785	1998	1206	1147	602
A6	5896	2038	1228	1168	614
A8	6008	2077	1250	1189	626
B0	6119	2117	1272	1210	638
B2	6230	2144	1301	1231	651
B4	6341	2183	1323	1252	663
B6	6453	2223	1345	1273	675
B8	6564	2262	1367	1294	687
C0	6675	2291	1395	1315	708

Table 4. Protective Characteristics of the UltraSIL Polymer-Housed VariSTAR U2 Surge Arrester

Arrester Rating U_r (kV, rms)	Arrester COV U_c (kV, rms)	Steep Current Residual Voltage (kV Crest)	Lightning Impulse Residual Voltage (kV Crest) 8/20 μ s Current Wave						Switching Impulse Residual Voltage (kV Crest) 30/60 Current Wave			
			1.5 kA	3 kA	5 kA	10 kA	20 kA	40 kA	125 A	250 A	500 A	1000 A
3	2.55	9.2	7.0	7.4	7.7	8.4	9.4	11.0	6.1	6.3	6.5	6.7
6	5.10	17.9	13.9	14.7	15.4	16.7	18.6	21.4	12.2	12.6	13.0	13.5
9	7.65	26.8	20.9	22.0	23.1	25.0	27.7	31.7	18.3	18.9	19.5	20.2
10	8.40	29.3	23.0	24.2	25.4	27.4	30.4	34.8	20.1	20.7	21.4	22.2
12	10.2	35.6	27.9	29.4	30.8	33.3	36.9	42.1	24.4	25.2	26.0	26.9
15	12.7	44.2	34.7	36.6	38.3	41.4	45.9	52.2	30.4	31.3	32.4	33.5
18	15.3	53.0	41.8	44.0	46.2	49.8	55.2	62.8	36.6	37.7	39.0	40.4
21	17.0	58.9	46.4	48.9	51.3	55.4	61.3	69.7	40.7	41.9	43.4	44.9
24	19.5	67.5	53.3	56.1	58.8	63.5	70.3	79.9	46.7	48.1	49.8	51.5
27	22.0	76.1	60.1	63.3	66.3	71.6	79.3	90.0	52.7	54.3	56.1	58.1
30	24.4	84.4	66.6	70.2	73.6	79.4	87.9	100	58.4	60.2	62.3	64.4
33	27.5	95.0	75.1	79.1	82.9	89.5	99.1	112	65.9	67.8	70.2	72.6
36	29.0	100	79.2	83.4	87.4	94.4	105	119	69.5	71.5	74.0	76.6
39	31.5	109	86.0	90.6	95.0	103	113	129	75.4	77.7	80.4	83.1
42	34.0	118	92.8	97.8	103	111	122	139	81.4	83.9	86.8	89.7
45	36.5	126	100	105	110	119	131	149	87.4	90.0	93.1	96.3
48	39.0	135	107	112	118	127	140	159	93.4	96.2	100	103
54	42.0	145	115	121	127	137	151	171	101	104	107	111
60	48.0	165	131	138	145	156	173	196	115	118	123	127
66	53.0	184	145	153	160	173	191	217	127	131	135	140
72	57.0	198	156	164	172	186	205	233	137	141	145	151
78	62.0	214	169	178	187	202	223	253	149	153	158	164
84	68.0	235	186	196	205	221	245	278	163	168	174	179
90	70.0	248	197	207	217	234	259	294	172	178	184	190
96	76.0	262	208	219	229	247	274	310	182	188	194	201
108	84.0	290	229	242	253	273	302	343	201	207	214	222
120	98.0	338	268	282	295	319	353	399	235	242	250	259
132	106	367	290	305	320	345	382	433	254	261	270	280
138	111	384	303	319	335	361	400	453	266	274	283	293
144	115	397	314	331	347	374	414	469	275	284	293	304
162	130	449	355	374	392	423	468	530	311	321	332	343
168	131	452	358	377	395	426	472	534	314	323	334	346
172	140	483	382	403	422	455	504	571	335	345	357	370
180	144	497	393	414	434	468	518	587	345	355	368	380
192	152	526	415	437	458	495	547	620	364	375	388	401
198	160	553	437	460	482	521	576	653	383	395	408	422
204	165	570	451	475	497	537	594	673	395	407	421	436
216	174	601	475	501	525	566	626	710	417	429	444	459
228	182	628	497	524	549	592	655	742	436	449	464	480
240	190	656	519	547	573	618	684	774	455	469	485	502

Dimensions and Mounting

Figure 4 illustrates an in-line mounting arrangement; the applicable values of "B" and "C" may be found in Table 5. Line and Earth terminal details are shown on Page 9, options 11 and 12. Figure 8 shows an outline drawing of the standard U2 UltraSIL Polymer-Housed VariSTAR Class 2 Arrester. The values for dimensions "A" and "D" for all ratings are listed in Table 5.

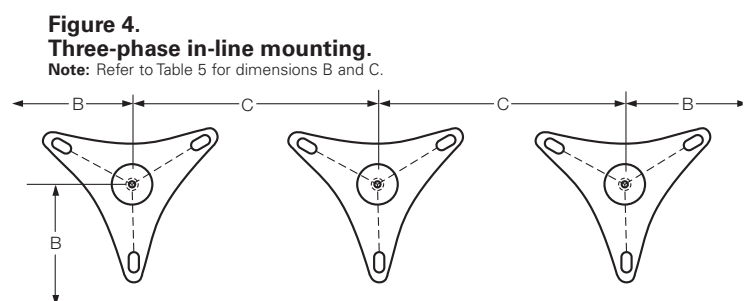

Table 5. Catalog Numbers and Dimensional Information and Weights for VariSTAR U2 Surge Arresters¹

Arrester Rating U _r (kV, rms)	Arrester COV U _c (kV, rms)	Standard Arrester Catalog Number	Dim. A (mm) (Fig. 8)	Dimension B Minimum Phase-to- Earth Clearance* (mm) (Fig. 4)	Dimension C Minimum Phase-to-Phase Clearance* (mm) (Fig. 4)	Dim. D (mm) (Fig. 8)	Housing Leakage Distance** (mm)	Arrester Mass (kg)
3	6	U200300206B5AAA	168	95	171	106	324	4.8
6	5.10	U200600506B5AAA	168	98	174	106	324	5.0
9	7.65	U200900708B5AAA	207	109	185	106	445	5.5
10	8.40	U201000808B5AAA	207	114	190	106	445	5.5
12	10.2	U201201010B5AAA	246	126	202	106	556	5.9
15	12.7	U201501212B5AAA	285	148	224	106	668	6.4
18	15.3	U201801512B5AAA	285	173	249	106	668	6.6
21	17.0	U202101712B5AAA	285	171	248	106	668	6.6
24	19.5	U202401914B5AAA	324	195	272	106	779	7.0
27	22.0	U202702216B5AAA	364	219	295	106	890	7.5
30	24.4	U203002418B5AAA	403	242	318	106	1001	8.0
33	27.5	U203302718B5AAA	403	272	348	106	1001	8.1
36	29.0	U203602918B5AAA	403	286	362	106	1001	8.1
39	31.5	U203903120B5AAA	442	312	388	106	1113	8.6
42	34.0	U204203422B5AAA	481	335	411	106	1224	9.1
45	36.5	U204503622B5AAA	481	359	435	106	1224	9.2
48	39.0	U204803926B5AAA	559	383	459	106	1446	10.1
54	42.0	U205404226B5AAA	559	412	488	106	1446	10.2
60	48.0	U206004830B5AAA	637	468	544	106	1669	11.2
66	53.0	U206605338B5AAA	779	518	594	106	2114	14.4
72	57.0	U207205740B5AAA	838	556	632	106	2225	14.9
78	62.0	U207806242B5AAA	877	604	680	106	2336	15.5
84	68.0	U208406846B5AAA	955	659	736	106	2559	16.4
90	70.0	U209007046B5AAA	955	698	774	106	2559	16.7
96	76.0	U209607648B5AA1	994	736	812	106	2670	17.2
108	84.0	U210808454B5AA1	1112	813	889	106	3004	18.6
120	98.0	U21200986045AA1	1229	948	1024	106	3338	21.0
132	106	U21321067645AA1	1618	1279	1609	106	4228	28.0
138	111	U21381117845AA1	1657	1326	1656	106	4339	29.0
144	115	U21441157845AA1	1657	1364	1694	106	4339	29.0
162	130	U21621308645AA1	1814	1509	1839	106	4784	31.0
168	131	U21681318645AA1	1814	1518	1848	106	4784	31.0
172	140	U21721408845AA1	1853	1603	1933	106	4895	32.0
180	144	U21801449045AA1	1892	1641	1972	106	5006	33.0
192	152	U2192152A445AA1	2170	1721	2051	106	5785	37.0
198	160	U2198160A845AA1	2249	1798	2128	106	6008	39.0
204	165	U2204165B045AA1	2288	1845	2175	106	6119	39.0
216	174	U2216174B445AA1	2366	1930	2260	106	6341	40.0
228	182	U2228182B645AA1	2405	2007	2337	106	6453	41.0
240	190	U2240190C045AA1	2483	2083	2414	106	6675	42.0

Notes:

1. Refer to Figure 4 for illustrations of dimensions B and C and Figure 8 for dimensions A and D.

* Phase-to-Phase clearances are expressed as minimum arrester center-to-center distances. Phase-to-Earth clearances are expressed as minimum arrester centerline-to-ground distances.

** Leakage distances shown are for standard housing – see page 8, digits 9 & 10 for optional housings available.

UltraQUIK™ Catalog Numbering System for UltraSIL Polymer-Housed VariSTAR Class 2 Arresters

1 U	2 2	3	4	5	6	7	8	9	10	11	12	13	14	15
--------	--------	---	---	---	---	---	---	---	----	----	----	----	----	----

Catalog Number Digits:

1 = "U" (UltraSIL Housed Arrester)

2 = "2" (IEC Class 2 Arrester)

3 through 8 = Arrester Rating, U_r (COV, U_c)

003002 = 3 kV (2.55 kV)	072057 = 72 kV (57.0 kV)
006005 = 6 kV (5.10 kV)	078062 = 78 kV (62.0 kV)
009007 = 9 kV (7.65 kV)	084068 = 84 kV (68.0 kV)
010008 = 10 kV (8.4 kV)	090070 = 90 kV (70.0 kV)
012010 = 12 kV (10.2 kV)	096076 = 96 kV (76.0 kV)
015012 = 15 kV (12.7 kV)	108084 = 108 kV (84.0 kV)
018015 = 18 kV (15.3 kV)	120098 = 120 kV (98.0 kV)
021017 = 21 kV (17.0 kV)	132106 = 132 kV (106 kV)
024019 = 24 kV (19.5 kV)	138111 = 138 kV (111 kV)
027022 = 27 kV (22.0 kV)	144115 = 144 kV (115 kV)
030024 = 30 kV (24.4 kV)	162130 = 162 kV (130 kV)
033027 = 33 kV (27.0 kV)	168131 = 168 kV (131 kV)
036029 = 36 kV (29.0 kV)	172140 = 172 kV (140 kV)
039031 = 39 kV (31.5 kV)	180144 = 180 kV (144 kV)
042034 = 42 kV (34.0 kV)	192152 = 192 kV (152 kV)
045036 = 45 kV (36.5 kV)	198160 = 198 kV (160 kV)
048039 = 48 kV (39.0 kV)	204165 = 204 kV (165 kV)
054042 = 54 kV (42.0 kV)	216174 = 216 kV (174 kV)
060048 = 60 kV (48.0 kV)	228182 = 228 kV (182 kV)
066053 = 66 kV (53.0 kV)	240190 = 240 kV (190 kV)

UltraQUIK Catalog Numbering System for UltraSIL Polymer-Housed VariSTAR Class 2 Arresters (Continued)

1 U	2 2	3	4	5	6	7	8	9	10	11	12	13	14	15
---------------	---------------	---	---	---	---	---	---	---	----	----	----	----	----	----

9 and 10 = Housing Code (Select from Table below):

* = Standard Housing

O = Housing Options

+ = Additional Housing Codes Available. Please contact your Eaton Sales Representative for information.

Ur Arrester Rating (kV rms)	Digits 9 & 10		06	08	10	12	14	16	18	20	22	24	26	28	30	36	38	40	42	44	46	48	50	52	54	56	58	60	
	Leakage Length (mm)		324	445	556	668	779	890	1001	1113	1224	1335	1446	1558	1669	2003	2114	2225	2336	2446	2559	2670	2781	2893	3004	3115	3226	3338	
3	*	0																											
6	*	0																											
9		*																											
10			*																										
12				*																									
15					*																								
18						*																							
21						*																							
24							*																						
27								*																					
30									*																				
33										*																			
36											*																		
39												*																	
42													*																
45											*																		
48												*																	
54													*																
60														*															
66															*														
72																*													
78																	*												
84																		*											
90																			*										
96																							*						
108																								*					
120																									*				

Ur Arrester Rating (kV rms)	Digits 9 & 10		72	74	76	78	80	82	84	86	88	90	92	94	96	98	A0	A2	A4	A6	A8	B0	B2	B4	B6	B8	C0	
	Leakage Length (mm)		4005	4116	4228	4339	4450	4561	4673	4784	4895	5006	5118	5229	5340	5451	5563	5674	5785	5896	6008	6119	6230	6341	6453	6564	6675	
120			+	+																								
132					*																							
138						*																						
144							*																					
162								*																				
168									*																			
172										*																		
180											*																	
192												*																
198																					*							
204																						*						
216																							*					
228																									*			
240																										*		

UltraQUIK Catalog Numbering System for UltraSIL Polymer-Housed VariSTAR Class 2 Arresters (Continued)

1	2	3	4	5	6	7	8	9	10	11	12	13	14	15
---	---	---	---	---	---	---	---	---	----	----	----	----	----	----

11 = Line terminal options

For U2 (3-108 kV) only

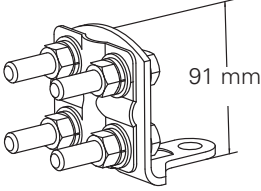
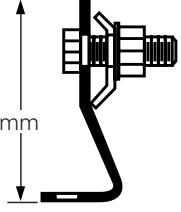
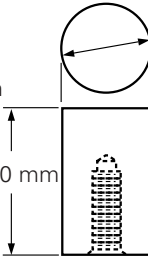
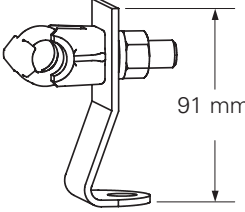
 <p>B = NEMA Four-hole Pad Accepts Copper or Aluminum Conductors up to 20 mm Ø (Standard)</p>	 <p>C = Clamp Style Connector Accepts Copper or Aluminum Stranded Conductors up to 14 mm Ø</p>	<p>D = 100 mm X 30 mm Ø Aluminum Cylindrical Stem Connector</p> <p>H = same as D but with 26 mm Ø</p> 	 <p>E = Eyebolt Connector Accepts Copper or Aluminum Conductors up to 14 mm Ø</p>
--	--	--	---

For U2 (120-240 kV) only

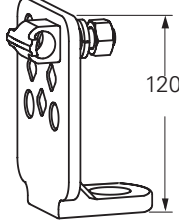
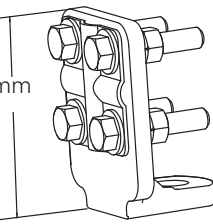
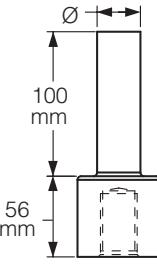
 <p>1 = Eyebolt Connector Accepts Copper or Aluminum Conductors up to 14 mm Ø</p>	 <p>4 = NEMA Four-hole Pad Accepts Copper or Aluminum Conductors up to 29 mm Ø (Standard)</p>	<p>D = 100 mm X 30 mm Ø Aluminum Cylindrical Stem Connector</p> <p>H = same as D but with 26 mm Ø</p> 
--	---	--

12 = Earth terminal options

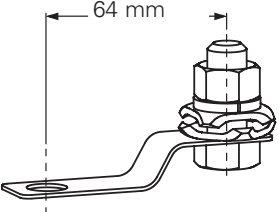
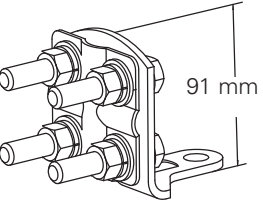
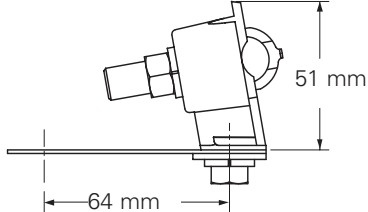
 <p>2 = Clamp Style Connector Accepts Copper or Aluminum Stranded Conductors up to 13 mm Ø</p>	 <p>5 = NEMA Four-hole Pad Accepts Copper or Aluminum Conductors up to 20 mm Ø (Standard)</p>	 <p>9 = Eyebolt Connector Accepts Copper or Aluminum Conductors up to 14 mm Ø</p>
--	--	--

13 = Mounting arrangement

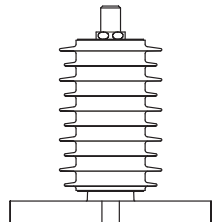
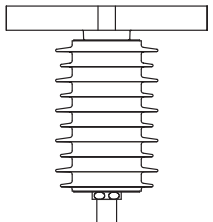
 <p>A = Mounting Base Located at Bottom (Standard)</p>	 <p>C = Mounting Base Located on Top (Inverted Suspension Mount)</p>
---	--

UltraQUIK Catalog Numbering System for UltraSIL Polymer-Housed VariSTAR Class 2 Arresters (Continued)

1	U	2														
---	---	---	--	--	--	--	--	--	--	--	--	--	--	--	--	--

14 = Nameplate information, see figures 6 and 7

Nameplate information is per IEC 60099-4 and is available in the following languages.

Specify:

A = English **B** = Spanish **C** = Portuguese

15 = Packaging

Arresters with housing codes 60 or less are shipped complete, ready for installation. Arresters with housing codes greater than 60 are shipped unassembled, requiring assembly during installation.

A = Export packing, individually packed in cartons – housings 06 through 46.

1 = Export packing, individually packed in cartons – housings 48 and higher.

Nameplate information

A stainless steel nameplate is attached to the base of every UltraSIL Polymer-Housed Type U2 Arrester. The arrester catalog number, serial number, year of manufacture, Ur, Uc, and pressure relief rating are among the details provided on the nameplate. See Figure 5 for an example of a base nameplate. For multi-unit arresters with housing codes greater than 60, an additional nameplate is provided on the base as shown in Figure 6.

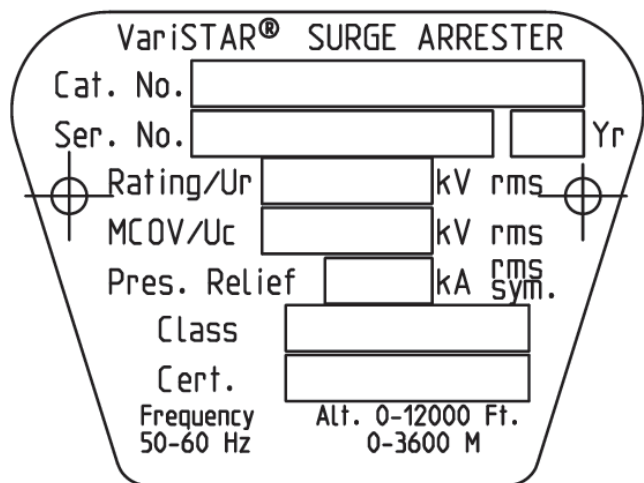

Figure 5. Arrester base nameplate (English version).

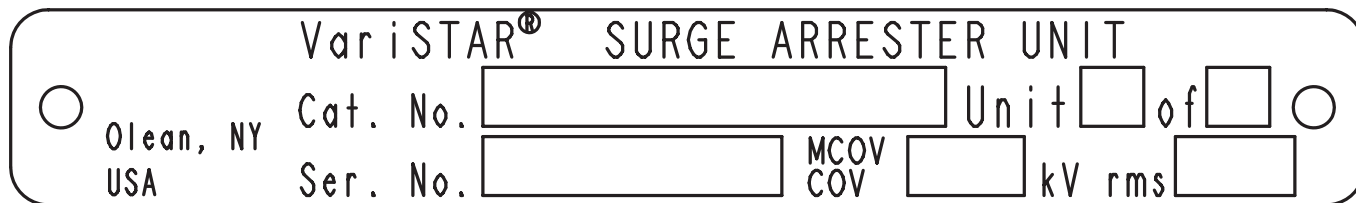
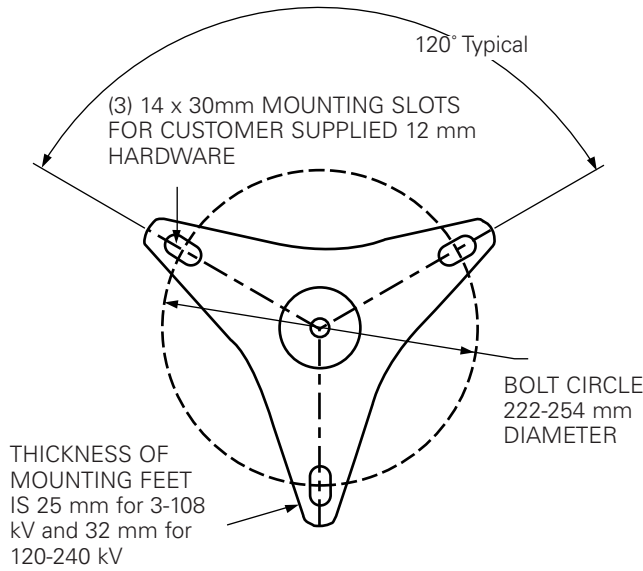

Figure 6. Detail of unit nameplate on arrester base.

Figure 7.
Base mounting.



Additional information

Table 6.
Product literature

CP0408	Certified Test Report
IS235-96-1	Service and Installation Instruction

Figure 8.
Outline drawing of standard UltraSIL Polymer-Housed VariSTAR Type U2 Surge Arresters.

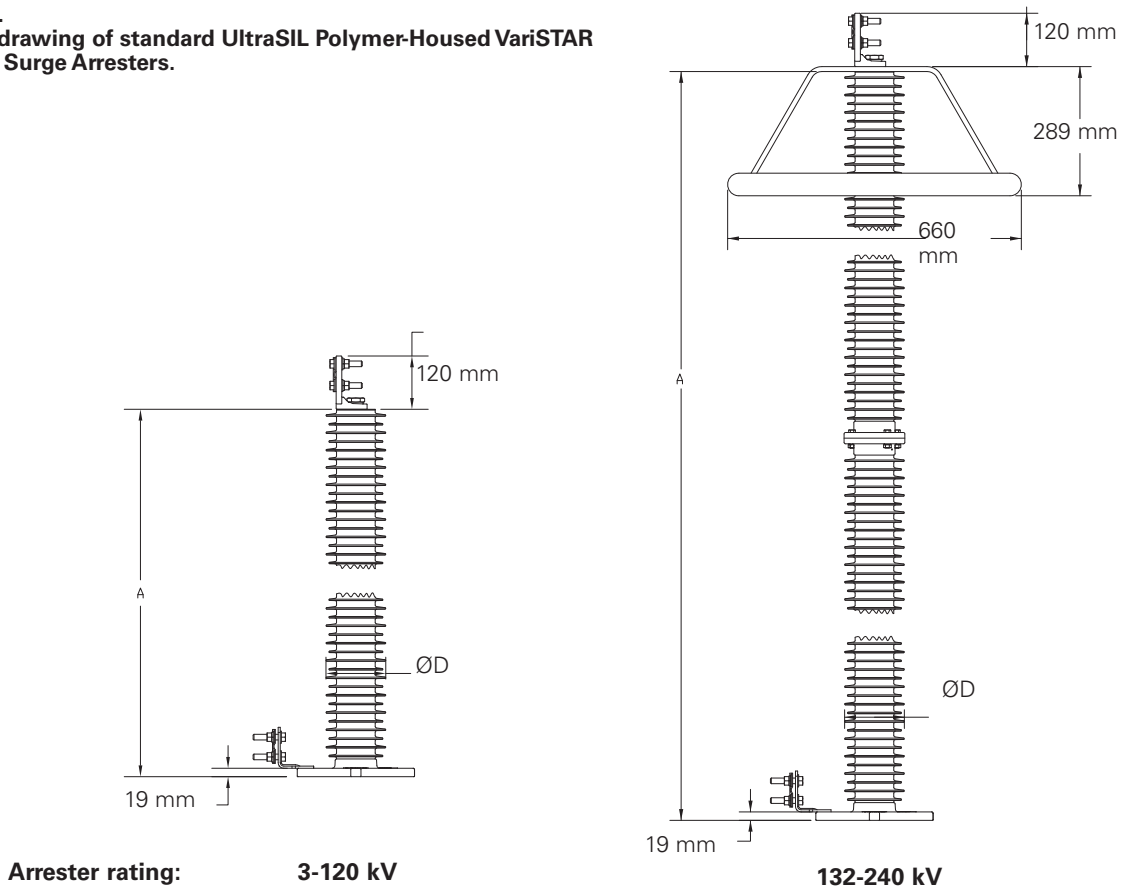

Notes:

Refer to Table 5 for dimensions A and D. Arresters shown with standard line terminal, Option B in digit 11 (3-108 kV) and Option 4 in digit 11 (120-240 kV) and with standard earth terminal Option 5 in digit 12.

Outlines in Figure 8 represent standard arrester catalog numbers from Table 5. Outline dimensions will vary when optional housing codes are selected from page 8. Consult factory for more information.

Eaton
1000 Eaton Boulevard
Cleveland, OH 44122
United States
Eaton.com

Eaton's Power Systems Division
2300 Badger Drive
Waukesha, WI 53188
United States
Eaton.com/cooperpowerseries

© 2016 Eaton
All Rights Reserved
Printed in USA
Publication No. CA235033EN

Eaton is a registered trademark.

All trademarks are property
of their respective owners.

For Eaton's Cooper Power series product
information call 1-877-277-4636 or visit:
www.eaton.com/cooperpowerseries.