

# UltraSIL<sup>®</sup> polymer-housed VariSTAR<sup>™</sup> station-class surge arresters



## General

Eaton has set a new standard of excellence for polymer-housed station-class surge arresters with its Cooper Power<sup>™</sup> series UltraSIL<sup>®</sup> polymer-housed surge arresters. Enhancements in arrester design allow Eaton to offer increased cantilever strength and improved energy handling capability. Eaton's Cooper Power series VariSTAR<sup>®</sup> Type US, UH, and UX station-class arresters incorporate the industry recognized superior silicone rubber housing with a unique high creep alternating shed profile designed to withstand the most extreme environments. The "standard" silicone rubber housing is designed with a minimum specific creepage distance of 31 mm/kV L-L, which meets category IV (Very Heavy) pollution level according to the IEC standard. This housing is applied over a gapless MOV internal design.

Types US, UH, and UX arresters meet or exceed the requirements of IEEE Std C62.11<sup>™</sup>-2005 standard including Short Circuit Tests performed in accordance with IEEE Std C62.11a<sup>™</sup>-2008 standard.

**EATON**

*Powering Business Worldwide*

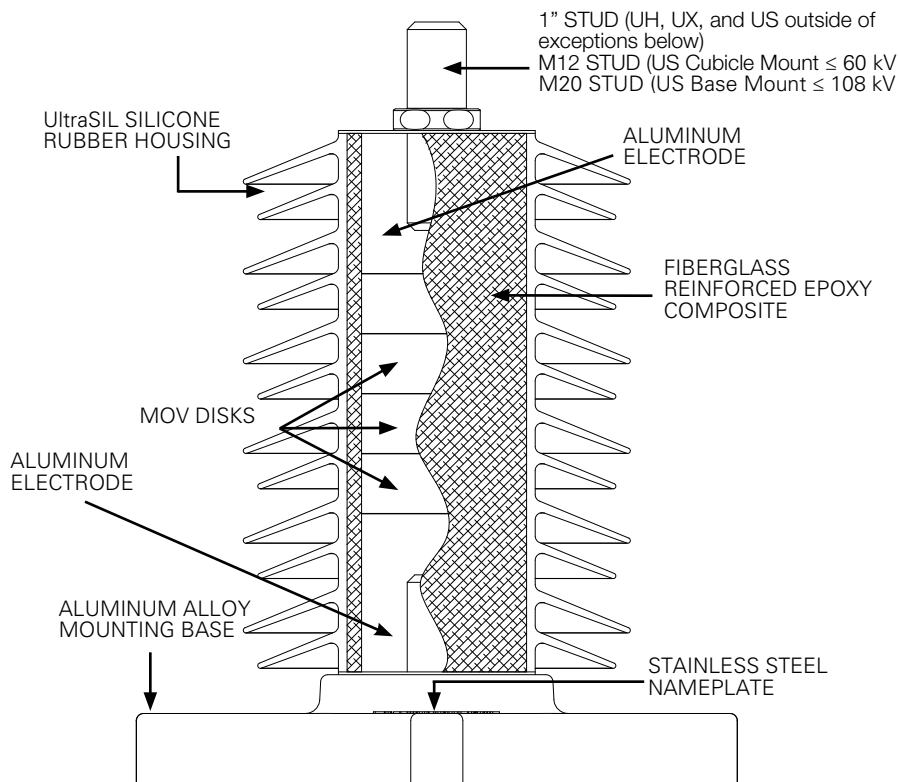

**Table 1. UltraSIL (US, UH, and UX) Station-Class Ratings and Characteristics**

Arrester Characteristic	Rating
Arrester Voltage Ratings (kV)	3-240
<b>Cantilever Strength (in-lbs)</b>	<b>Ultimate MDCL-Static**</b>
US (3-108 kV)	15,000 6,000
UH (3-108 kV) US (120-240 kV)	20,000 8,000
UX (3-108 kV) UH (120-240 kV)	35,000 14,000
<b>Rated Discharge Energy (kJ/kV of MCOV)</b>	<b>Single Impulse Rating</b>
US (3-108 kV)	3.9
UH (3-108 kV) US (120-240 kV)	6.2
UX (3-108 kV) UH (120-240 kV)	10
High Current Withstand* (kA)	100
Impulse Classifying Current (kA)	10
Pressure Relief Rating (kA rms sym.)	63
System Frequency (Hz)	50/60

\* High current, short duration withstand (100 kA, 4/10 μs)

\*\* Maximum design cantilever load—static or maximum working load is 40% of the ultimate.

**Figure 1. Illustration of 10 kV UltraSIL Polymer-Housed VariSTAR Station-Class Arrester.**

**Construction**

The unique construction of UltraSIL polymer-housed Type US, UH, and UX station-class arresters begins with world class Metal Oxide Varistor (MOV) disks produced at our dedicated manufacturing facility in Olean, NY. By manufacturing our own disks we maintain a strict quality control over the entire production process, from initial raw material inspection to final physical and electrical testing of each disk. In addition, by controlling the manufacturing process of both disks and arresters, we achieve the optimal combination. Eaton produces MOV disks of unsurpassed quality through continuous improvements in disk formulation and manufacturing technology. The end result is a long history of in-service use with outstanding durability and protective capability.

Arrester production begins by stacking glass-collared MOV disks in series with aluminum end electrodes. Our proprietary process wraps the assembly with a woven fiberglass-reinforced epoxy composite. When cured, the arrester module is capable of withstanding heavy electrical and cantilever load conditions.

The UltraSIL silicone rubber housing utilizes an interference fit and is bonded onto the internal module to form a solid, void-free, high-dielectric strength insulation system. Once assembled, each arrester must pass a strict series of electrical tests to insure the highest level of in-service performance.

The silicone rubber housing results in lighter weight than similarly rated porcelain-housed arresters. The silicone rubber housing is less sensitive to physical damage than porcelain. Also, when compared to other polymeric housing materials, silicone rubber generates significantly lower external power losses under contaminated conditions.

**Features**

The UltraSIL silicone rubber housing was selected for its superior insulation performance as compared to other polymeric housing materials. Long term environmental testing has verified the lifetime performance advantage that silicone rubber provides.

Independent laboratory tests have verified the superior water repellent behavior of silicone rubber, which is responsible for the lower external power losses, higher resistance to UV degradation and surface tracking, superior performance in contaminated environments, and other important insulating properties. Also, UltraSIL silicone rubber has been proven to be non-flammable and self-extinguishing per UL 94V0 standards.

The basic silicone rubber-housed arrester can be customized with a variety of terminal and mounting options which allow users to select the features that meet their application needs. Customers who require longer creepage housings can easily select a different housing option through the catalog numbering system. See pages 14-15 for a complete list of available options.

**Operation**

The operation of the UltraSIL polymer-housed Type US, UH, and UX arrester is typical of gapless metal oxide arresters. During steady-state conditions, line-to-ground voltage is applied continuously between the line and ground terminals of the arrester. When surges occur, the arrester immediately limits, or clamps, the overvoltage condition by conducting the surge current to ground. After passage of the surge, the arrester returns to its initial state, conducting minimal leakage current. This minimal leakage current (which is primarily capacitive, with a small resistive component) can be withstood on a continuing basis.

The UltraSIL polymer-housed Type US, UH, and UX arresters easily surpass the minimum fault current withstand requirements for station-class arresters as defined in IEEE Std C62.11a™-2008 standard (40 kA). These arresters have been tested and shown to withstand fault currents of 63 kA. During these tests, the silicone

rubber housing ruptures without expelling internal parts.

UltraSIL polymer-housed Type US, UH, and UX arresters are ideal for protection against repeated high energy switching surges and provide reliable protection for substation equipment, capacitor banks, multiple lines, and cable circuits. They are also ideal for applications where lighter weight and shorter heights (when compared to porcelain-housed arresters) are critical.

**Design testing**

The housing, internal components, and hardware of an arrester must work together as a system. This system must stand up to years of service while being subjected to a wide range of environmental and electrical stresses. To ensure a superior level of performance, both arrester components and finished arresters have been subjected to a series of tests that accurately represents years of exposure to actual field conditions. This testing far exceeds the requirements of industry standards.

The UltraSIL polymer-housed arrester has also met or exceeded all requirements for station-class arresters as defined by IEEE Std C62.11™-2005 standard. Reference *CP1121 UltraSIL Polymer-Housed VariSTAR Type US, UH and UX Station-Class Surge Arresters Certified Test Report*.

The Type US, UH, and UX arresters are USDA's Rural Utilities Service (RUS) Section ae approved, meeting or exceeding all RUS technical specification and workmanship.

**Production tests**

Eaton has implemented a complete production test program to ensure a quality product. Each MOV disk is subjected to a series of electrical tests to maintain quality. We also perform additional tests on every MOV disk batch. Listed below are the tests performed on the MOV disks:

- 100% Physical Inspection
- 100% Discharge Voltage Test
- 100% Vref at Iref
- 100% Watt Loss Measured at 1.05 x MCOV
- 100% Transmission Line Discharge Energy Test
- Batch High-Current, Short-Duration Test
- Batch Thermal Stability Test
- Batch Aging Test

Each fully assembled UltraSIL polymer-housed station-class arrester must also pass the following production tests:

- 100% Physical Inspection
- 100% Vref Test
- 100% Watt Loss Test
- 100% Partial Discharge Inception Voltage Test

**General application recommendations**

The rating of an arrester is the maximum power-frequency line-to-ground voltage at which the arrester is designed to pass an operating duty-cycle test (as defined in IEEE Std C62.11™-2005 standard). Table 2 provides a general application guide for the selection of the proper arrester rating for a given system voltage and grounding configurations as outlined in IEEE Std C62.22™-2009 standard, which is the application guide for metal oxide surge arresters.

Under fault conditions and other system anomalies, higher than normal voltages can be imposed upon an arrester. With an improper arrester selection, these abnormal system voltages can cause an arrester to fail. To help ensure that the proper arrester is selected, Eaton's application engineers are available to make recommendations.

**Table 2. Recommended Arrester Applications for VariSTAR Station-Class Arresters**

System Voltage (kV rms)		Recommended Arrester Rating (MCOV)	
Nominal	Maximum	Three-Wire or Four-Wire Wye Solidly Grounded Neutral	Delta and Ungrounded Wye
2.4	2.52	3 (2.55)	3 (2.55)
4.16	4.37	3 (2.55)	6 (5.10)
4.8	5.04	—	6 (5.10)
6.9	7.25	6 (5.10)	9 (7.65)
8.32	8.74	6 (5.10)	9 (7.65) 10 (8.40)
12.0	12.6	9 (7.65) 10 (8.40)	12 (10.2) 15 (12.7)
12.47	13.1	9 (7.65) 10 (8.40)	15 (12.7) 18 (15.3)
13.2	13.9	10 (8.40) 12 (10.2)	15 (12.7) —
13.8	14.5	10 (8.40) 12 (10.2)	15 (12.7) 18 (15.3)
20.78	21.8	15 (12.7) 21 (17.0)	24 (19.5) 27 (22.0)
22.86	24.0	18 (15.3) 21 (17.0)	24 (19.5) 27 (22.0)
24.9	26.2	18 (15.3) 21 (17.0)	24 (19.5) 27 (22.0)
34.5	36.2	27 (22.0) 30 (24.4)	36 (29.0) 39 (31.5)
46.0	48.3	36 (29.0) 39 (31.5)	48 (39.0) —
69.0	72.5	54 (42.0) 60 (48.0)	72 (57.0) —
115	121	90 (70.0) 96 (76.0)	108 (84.0) —
138	145	108 (84.0) 120 (98.0)	132 (106) 144 (115)
161	169	120 (98.0) 132 (106) 144 (115)	144 (115) 168 (131) —
230	242	172 (140) 180 (144) 192 (152)	228 (180) 240 (190) —

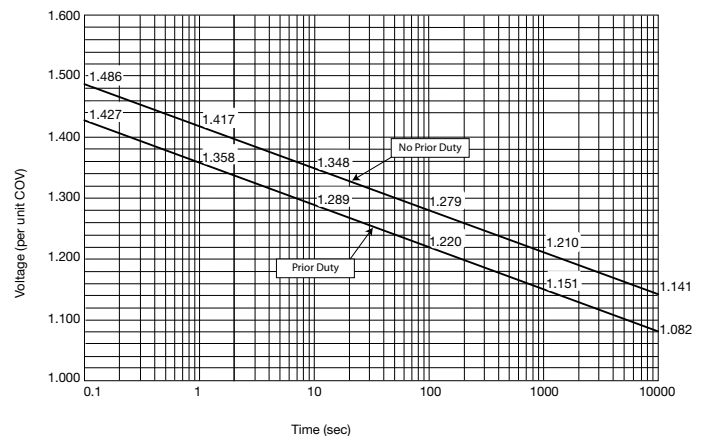

**Figure 2. Temporary overvoltage curve – 60° ambient temperature.**

The following information is normally required:

1. Maximum system operating voltage.
2. System grounding conditions;
  - A. For four-wire circuits, grounding conditions depend upon whether the system is multi-grounded, whether it has a neutral impedance and whether common primary and secondary neutrals are used.
  - B. For three-wire circuits, grounding conditions depend upon whether the system is solidly grounded at the source, grounded through neutral impedance at the source transformers or ungrounded.
3. Available Fault Current.
4. Maximum line-to-ground voltage and overvoltage duration during fault conditions.

Contact your Eaton representative to have your individual system application needs reviewed.

### Temporary overvoltage (TOV) withstand ability

The UltraSIL polymer-housed Type US, UH, and UX arrester's ability to withstand 60 Hz overvoltage conditions (TOVs) is shown in Figure 2. The graph illustrates the time an arrester can survive a voltage, and recover, without going into thermal runaway, for a given voltage magnitude (expressed in Per Unit of arrester MCOV).

The graphs in Figure 2 illustrate TOV withstand ability, with and without prior duty. The prior duty curve is based upon absorption of rated energy (Refer to Table 1 — Single Impulse Rating) immediately preceding application of the overvoltage.

### Mounting information

The standard base of the UltraSIL polymer-housed Type US, UH, and UX arresters is designed for mounting on 8.75" or 10" diameter bolt circle patterns. The three slotted mounting holes are spaced 120° from each other and are designed to handle 0.5" diameter bolts. Mounting hardware (bolts, nuts, and washers) is not included with the arrester. See Figure 3 for mounting base details. An inherently strong design allows these arresters to be mounted in a variety of ways. They can be mounted vertically, with attachment at the base, or suspension (underhung) mounted. Eaton offers more flexibility for customers to mount arresters in the field. Station-class arresters can be configured in the underhung position (suspension mount) at the plant or with a unique new option assembled in the field in the underhung position\*. UltraSIL polymer-housed station-class arresters can also be horizontally mounted through 120 kV.

\* Field base conversion for Types UH and UX only.

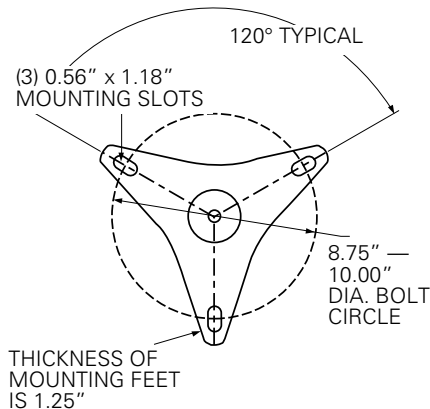

Figure 3. Mounting base details.

### Ordering information

Table 3 includes the shortened catalog numbers for UltraSIL polymer-housed Type US, UH, and UX arresters. The arrester represented by the shortened catalog number is configured with the standard configurations shown in Table 10. The shortened catalog numbers shown in Table 3 represent the same catalog numbers shown in Table 9. For example, catalog number USAA060A from Table 3 represents the same catalog number USAA060048A2845A11 from Table 9. Eaton offers other options that allow customers to select specific features they desire. Options on housing sizes (creepage length), hardware, and mounting options are available and defined in Table 10. This table allows customers who prefer options different from those in our standard Table 9 configuration to develop a catalog number which provides the unique features they desire. For additional assistance please contact your Eaton representative.

Table 3. Shortened Catalog Numbers for Standard Configuration Types US, UH, and UX Surge Arresters

Arrester Rating (kV rms)	MCOV (kV rms)	Type US	Type UH	Type UX
3	2.55	USAA003A	UHAA003A	UXAA003A
6	5.1	USAA006A	UHAA006A	UXAA006A
9	7.65	USAA009A	UHAA009A	UXAA009A
10	8.4	USAA010A	UHAA010A	UXAA010A
12	10.2	USAA012A	UHAA012A	UXAA012A
15	12.7	USAA015A	UHAA015A	UXAA015A
18	15.3	USAA018A	UHAA018A	UXAA018A
21	17.0	USAA021A	UHAA021A	UXAA021A
24	19.5	USAA024A	UHAA024A	UXAA024A
27	22	USAA027A	UHAA027A	UXAA027A
30	24.4	USAA030A	UHAA030A	UXAA030A
33	27.5	USAA033A	UHAA033A	UXAA033A
36	29	USAA036A	UHAA036A	UXAA036A
39	31.5	USAA039A	UHAA039A	UXAA039A
42	34	USAA042A	UHAA042A	UXAA042A
45	36.5	USAA045A	UHAA045A	UXAA045A
48	39	USAA048A	UHAA048A	UXAA048A
54	42	USAA054A	UHAA054A	UXAA054A
60	48	USAA060A	UHAA060A	UXAA060A
66	53	USAA066A	UHAA066A	UXAA066A
72	57	USAA072A	UHAA072A	UXAA072A
78	62	USAA078A	UHAA078A	UXAA078A
84	68	USAA084A	UHAA084A	UXAA084A
90	72	USAA090A	UHAA090A	UXAA090A
96	76	USAA096A	UHAA096A	UXAA096A
108	84	USAA108A	UHAA108A	UXAA108A
120	98	USAA120A	UHAA120A	-
132	106	USAA132A	UHAA132A	-
138	111	USAA138A	UHAA138A	-
144	115	USAA144A	UHAA144A	-
162	130	USAA162A	UHAA162A	-
168	131	USAA168A	UHAA168A	-
172	140	USAA172A	UHAA172A	-
180	144	USAA180A	UHAA180A	-
192	152	USAA192A	UHAA192A	-
198	160	USAA198A	UHAA198A	-
204	165	USAA204A	UHAA204A	-
216	174	USAA216A	UHAA216A	-
228	180	USAA228A	UHAA228A	-
240	190	USAA240A	UHAA240A	-

## Protective characteristics

All UltraSIL polymer-housed Type US, UH, and UX arresters provide excellent overvoltage protection for electrical equipment. The specific protective characteristics for each arrester rating are shown in Table 4 for US arresters, Table 5 for UH arresters and Table 6 for UX arresters. Tables 5 and 6 are on pages 6 and 7, respectively.

**Table 4. Protective Characteristics of the UltraSIL Polymer-Housed Station-Class Arrester-Type US**

Arrester Rating (kV, rms)	Arrester MCOV (kV rms)	TOV*		Front-of-wave Protective Level** (kV Crest)	Maximum Discharge Voltage (kV Crest) 8/20 $\mu$ s Current Wave						Switching Surge Protective Level*** (kV crest)			
		1 Sec	10 Sec		1.5 kA	3 kA	5 kA	10 kA	20 kA	40 kA	125 A	250 A	500 A	1000 A
3	2.55	3.5	3.3	8.8	6.8	7.2	7.6	8.3	9.1	10.4	5.9	6.1	6.3	6.6
6	5.1	6.9	6.6	17.5	13.6	14.4	15.2	16.6	18.2	20.7	11.8	12.1	12.5	13.1
9	7.65	10.4	9.9	26.2	20.4	21.6	22.7	24.9	27.3	31.1	17.7	18.1	18.8	19.6
10	8.4	11.4	10.8	28.8	22.4	23.7	24.9	27.3	29.9	34.1	19.4	19.9	20.6	21.5
12	10.2	13.9	13.1	34.9	27.2	28.8	30.3	33.1	36.3	41.4	23.5	24.1	25	26.1
15	12.7	17.2	16.4	43.5	33.8	35.8	37.7	41.3	45.2	51.5	29.3	30.1	31.1	32.5
18	15.3	20.8	19.7	52.4	40.8	43.1	45.4	49.7	54.5	62.1	35.3	36.2	37.5	39.1
21	17	23.1	21.9	58.2	45.3	47.9	50.4	55.2	60.5	69	39.2	40.2	41.6	43.5
24	19.5	26.5	25.1	66.7	51.9	55	57.8	63.3	69.4	79.1	44.9	46.1	47.8	49.8
27	22	29.9	28.4	75.3	58.6	62	65.2	71.4	78.3	89.2	50.7	52	53.9	56.2
30	24.4	33.1	31.5	83.5	65	68.8	72.3	79.2	86.8	98.9	56.2	57.7	59.8	62.4
33	27.5	37.3	35.4	94.1	73.2	77.5	81.5	89.3	97.9	112	63.3	65	67.3	70.3
36	29	39.4	37.4	99.2	77.2	81.7	86	94.2	104	118	66.8	68.6	71	74.1
39	31.5	42.8	40.6	108	83.9	88.8	93.4	103	113	128	72.5	74.5	77.1	80.5
42	34	46.2	43.8	117	90.5	95.8	101	111	121	138	78.3	80.4	83.2	86.9
45	36.5	49.6	47	125	97.2	103	109	119	130	148	84	86.3	89.4	93.3
48	39	53	50.3	134	104	110	116	127	139	159	89.8	92.2	95.5	99.6
54	42	57	54.1	144	112	119	125	137	150	171	96.7	99.3	103	108
60	48	65.2	61.9	165	128	136	143	156	171	195	111	114	118	123
66	53	72	68.3	182	142	150	158	172	189	215	122	126	130	136
72	57	77.4	73.5	195	152	161	169	185	203	232	132	135	140	146
78	62	84.2	79.9	213	165	175	184	202	221	252	143	147	152	159
84	68	92.3	87.7	233	181	192	202	221	242	276	157	161	167	174
90	72	97.8	92.8	247	192	203	214	234	257	292	166	171	177	184
96	76	103.2	98	260	203	215	226	247	271	309	175	180	186	195
108	84	114.1	108.3	288	224	237	249	273	299	341	194	199	206	215
120	98	133.1	126.3	314	250	263	275	298	323	361	219	225	232	241
132	106	143.9	136.6	339	270	285	298	323	349	390	237	243	251	261
138	111	150.7	143.1	355	283	298	312	338	366	408	248	255	263	273
144	115	156.2	148.2	368	293	309	323	350	379	423	257	264	272	283
162	130	176.5	167.6	416	331	349	365	396	429	478	291	298	308	319
168	131	177.9	168.9	419	334	352	368	399	432	482	293	300	310	322
172	140	190.1	180.5	448	357	376	393	426	461	515	313	321	331	344
180	144	195.6	185.6	461	367	387	404	438	475	530	322	330	341	354
192	152	206.4	195.9	486	387	408	427	463	501	559	340	348	360	373
198	160	217.3	206.2	512	408	430	449	487	527	589	358	367	378	393
204	165	224.1	212.7	528	420	443	463	502	544	607	369	378	390	405
216	174	236.3	224.3	556	443	467	488	529	573	640	389	399	412	427
228	180	244.4	232	576	459	483	505	548	593	662	402	413	426	442
240	190	258	244.9	608	484	510	533	578	626	699	424	435	449	467

\* Temporary Overvoltage (TOV) with Prior Duty.

\*\* Based on a 10 kA current impulse that results in a discharge voltage cresting in 0.5  $\mu$ s.

\*\*\* 45-60  $\mu$ s rise time for a 500 A peak current surge.

**Table 5. Protective Characteristics of the UltraSIL Polymer-Housed Station-Class Arrester-Type UH**

Arrester Rating (kV, rms)	Arrester MCOV (kV rms)	TOV*		Front-of-wave Protective Level** (kV Crest)	Maximum Discharge Voltage (kV Crest) 8/20µs Current Wave							Switching Surge Protective Level*** (kV crest)			
		1 Sec	10 Sec		1.5 kA	3 kA	5 kA	10 kA	20 kA	40 kA	125 A	250 A	500 A	1000 A	
3	2.55	3.5	3.3	8.2	6.5	6.9	7.2	7.8	8.4	9.4	5.7	5.9	6.1	6.3	
6	5.1	6.9	6.6	16.3	13	13.7	14.3	15.6	16.8	18.8	11.4	11.7	12.1	12.6	
9	7.65	10.4	9.9	24.5	19.5	20.6	21.5	23.3	25.2	28.2	17.1	17.6	18.1	18.8	
10	8.4	11.4	10.8	26.9	21.4	22.6	23.6	25.6	27.7	30.9	18.8	19.3	19.9	20.7	
12	10.2	13.9	13.1	32.6	26	27.4	28.6	31.1	33.6	37.5	22.8	23.4	24.1	25.1	
15	12.7	17.2	16.4	40.6	32.4	34.1	35.6	38.7	41.9	46.7	28.4	29.1	30	31.2	
18	15.3	20.8	19.7	48.9	39	41.1	42.9	46.6	50.4	56.3	34.2	35.1	36.2	37.6	
21	17	23.1	21.9	54.4	43.3	45.6	47.7	51.7	56	62.5	38	39	40.2	41.8	
24	19.5	26.5	25.1	62.4	49.7	52.3	54.7	59.3	64.2	71.7	43.6	44.7	46.1	47.9	
27	22	29.9	28.4	70.3	56	59	61.7	66.9	72.5	80.9	49.1	50.4	52	54	
30	24.4	33.1	31.5	78	62.1	65.5	68.4	74.2	80.4	89.7	54.5	55.9	57.7	59.9	
33	27.5	37.3	35.4	87.9	70	73.8	77.1	83.6	90.6	102	61.4	63	65	67.5	
36	29	39.4	37.4	92.7	73.8	77.8	81.3	88.2	95.5	107	64.8	66.4	68.6	71.2	
39	31.5	42.8	40.6	101	80.2	84.5	88.3	95.8	104	116	70.3	72.2	74.5	77.3	
42	34	46.2	43.8	109	86.6	91.2	95.3	104	112	125	75.9	77.9	80.4	83.5	
45	36.5	49.6	47	117	92.9	97.9	103	111	121	135	81.5	83.6	86.3	89.6	
48	39	53	50.3	125	99.3	105	110	119	129	144	87.1	89.3	92.2	95.7	
54	42	57	54.1	135	107	113	118	128	139	155	93.8	96.2	99.3	104	
60	48	65.2	61.9	154	123	129	135	146	159	177	108	110	114	118	
66	53	72	68.3	170	135	143	149	162	175	195	119	122	126	131	
72	57	77.4	73.5	183	146	153	160	174	188	210	128	131	135	140	
78	62	84.2	79.9	199	158	167	174	189	205	228	139	142	147	153	
84	68	92.3	87.7	218	174	183	191	207	224	250	152	156	161	167	
90	72	97.8	92.8	231	184	194	202	219	238	265	161	165	171	177	
96	76	103.2	98	243	194	204	214	232	251	280	170	174	180	187	
108	84	114.1	108.3	269	214	226	236	256	277	309	188	193	199	207	
120	98	133.1	126.3	297	242	253	263	284	303	334	214	219	226	234	
132	106	143.9	136.6	321	262	274	285	307	328	361	232	237	244	253	
138	111	150.7	143.1	336	274	287	298	321	343	378	243	248	256	265	
144	115	156.2	148.2	348	284	297	309	333	356	392	251	257	265	274	
162	130	176.5	167.6	394	321	336	349	376	402	443	284	291	300	310	
168	131	177.9	168.9	397	323	339	352	379	405	446	286	293	302	312	
172	140	190.1	180.5	424	346	362	376	405	433	477	306	313	323	334	
180	144	195.6	185.6	436	355	372	387	417	445	491	315	322	332	343	
192	152	206.4	195.9	460	375	393	408	440	470	518	332	340	350	362	
198	160	217.3	206.2	485	395	413	430	463	495	545	350	358	369	382	
204	165	224.1	212.7	500	407	426	443	477	510	562	361	369	380	393	
216	174	236.3	224.3	527	429	450	467	503	538	593	380	389	401	415	
228	180	244.4	232	545	444	465	483	521	557	613	393	403	415	429	
240	190	258	244.9	575	469	491	510	550	587	647	415	425	438	453	

\* Temporary Overvoltage (TOV) with Prior Duty.

\*\* Based on a 10 kA current impulse that results in a discharge voltage cresting in 0.5 µs.

\*\*\* 45-60 µs rise time for a 500 A peak current surge.

**Table 6. Protective Characteristics of the UltraSIL Polymer-Housed Station-Class Arrester-Type UX**

Arrester Rating (kV, rms)	Arrester MCOV (kV rms)	TOV*		Front-of-wave Protective Level** (kV Crest)	Maximum Discharge Voltage (kV Crest 8/20 $\mu$ s Current Wave)						Switching Surge Protective Level*** (kV Crest)			
		1 Sec	10 Sec		1.5 kA	3 kA	5 kA	10 kA	20 kA	40 kA	125 A	250 A	500 A	1000 A
3	2.55	3.5	3.3	7.8	6.3	6.6	6.9	7.4	7.9	8.7	5.6	5.7	5.9	6.1
6	5.1	6.9	6.6	15.5	12.6	13.2	13.7	14.8	15.8	17.4	11.2	11.4	11.8	12.2
9	7.65	10.4	9.9	23.2	18.9	19.8	20.6	22.2	23.7	26.1	16.7	17.1	17.6	18.3
10	8.4	11.4	10.8	25.5	20.8	21.7	22.6	24.3	26	28.6	18.4	18.8	19.4	20.1
12	10.2	13.9	13.1	30.9	25.2	26.4	27.4	29.5	31.6	34.8	22.3	22.8	23.5	24.3
15	12.7	17.2	16.4	38.5	31.4	32.8	34.1	36.8	39.3	43.3	27.8	28.4	29.3	30.3
18	15.3	20.8	19.7	46.3	37.8	39.5	41.1	44.3	47.3	52.1	33.4	34.2	35.2	36.5
21	17	23.1	21.9	51.5	42	43.9	45.6	49.2	52.6	57.9	37.1	38	39.2	40.5
24	19.5	26.5	25.1	59.1	48.1	50.4	52.3	56.4	60.3	66.4	42.6	43.6	44.9	46.5
27	22	29.9	28.4	66.6	54.3	56.8	59.1	63.6	68	74.9	48.1	49.2	50.7	52.4
30	24.4	33.1	31.5	73.9	60.2	63	65.5	70.6	75.4	83.1	53.3	54.6	56.2	58.2
33	27.5	37.3	35.4	83.3	67.8	71	73.8	79.5	85	93.7	60.1	61.5	63.3	65.5
36	29	39.4	37.4	87.8	71.5	74.9	77.8	83.9	89.6	98.8	63.3	64.8	66.8	69.1
39	31.5	42.8	40.6	95.4	77.7	81.3	84.5	91.1	97.4	108	68.8	70.4	72.5	75.1
42	34	46.2	43.8	103	83.9	87.8	91.2	98.3	106	116	74.2	76	78.3	81
45	36.5	49.6	47	111	90	94.2	97.9	106	113	125	79.7	81.6	84	87
48	39	53	50.3	119	96.2	101	105	113	121	133	85.1	87.2	89.8	92.9
54	42	57	54.1	128	104	109	113	122	130	143	91.7	93.9	96.7	101
60	48	65.2	61.9	146	119	124	129	139	149	164	105	108	111	115
66	53	72	68.3	161	131	137	143	154	164	181	116	119	122	127
72	57	77.4	73.5	173	141	148	153	165	177	195	125	128	132	136
78	62	84.2	79.9	188	153	161	167	180	192	212	136	139	143	148
84	68	92.3	87.7	206	168	176	183	197	211	232	149	152	157	162
90	72	97.8	92.8	218	178	186	194	209	223	246	158	161	166	172
96	76	103.2	98	230	188	197	204	220	235	259	166	170	175	181
108	84	114.1	108.3	255	208	217	226	243	260	286	184	188	194	201

\* Temporary Overvoltage (TOV) with Prior Duty.

\*\* Based on a 10 kA current impulse that results in a discharge voltage cresting in 0.5  $\mu$ s.\*\*\* 45-60  $\mu$ s rise time for a 500 A peak current surge.

**Table 7. Creepage Distances and Insulation Withstand Voltages of UltraSIL Polymer-Housed Station-Class Arresters**

Arrester Rating (kV, rms)	Arrester MCOV (kV, rms)	Creepage Distance (Inches)			Insulation Withstand Voltages											
					1.2/50 Impulse (kV, Crest)			Switching Surge Impulse (kV, Crest)			60 Hz, dry 60 Seconds (kV, rms)			60 Hz, wet 10 Seconds (kV, rms)		
		US	UH	UX	US	UH	UX	US	UH	UX	US	UH	UX	US	UH	UX
3	2.55	30.7	30.7	30.7	115	119	126	N/A	N/A	N/A	80	77	82	64	63	60
6	5.1	38.4	38.4	38.4	134	137	138	N/A	N/A	N/A	94	90	90	75	75	71
9	7.65	38.4	38.4	38.4	134	137	138	N/A	N/A	N/A	94	90	90	75	75	71
10	8.4	38.4	38.4	38.4	134	137	138	N/A	N/A	N/A	94	90	90	75	75	71
12	10.2	46.1	46.1	46.1	155	158	159	N/A	N/A	N/A	109	104	104	88	88	84
15	12.7	46.1	46.1	46.1	155	158	159	N/A	N/A	N/A	109	104	104	88	88	84
18	15.3	53.7	53.7	53.7	176	178	179	N/A	N/A	N/A	123	118	117	101	101	97
21	17.0	53.7	53.7	53.7	176	178	179	N/A	N/A	N/A	123	118	117	101	101	97
24	19.5	61.4	61.4	61.4	201	201	206	N/A	N/A	N/A	140	140	135	113	113	116
27	22.0	61.4	61.4	61.4	201	201	206	N/A	N/A	N/A	140	140	135	113	113	116
30	24.4	69.1	69.1	69.1	217	218	220	N/A	N/A	N/A	151	146	144	126	128	123
33	27.5	69.1	69.1	69.1	217	218	220	N/A	N/A	N/A	151	146	144	126	128	123
36	29.0	69.1	69.1	69.1	217	218	220	N/A	N/A	N/A	151	146	144	126	128	123
39	31.5	84.4	84.4	84.4	252	258	262	N/A	N/A	N/A	172	166	168	152	156	154
42	34.0	84.4	84.4	84.4	252	258	262	N/A	N/A	N/A	172	166	168	152	156	154
45	36.5	92.1	92.1	92.1	275	279	281	N/A	N/A	N/A	188	188	184	162	167	162
48	39.0	99.8	99.8	99.8	294	298	300	N/A	N/A	N/A	201	201	202	173	186	176
54	42.0	99.8	99.8	99.8	294	298	300	N/A	N/A	N/A	201	201	202	173	186	176
60	48.0	107.5	107.5	107.5	316	319	321	N/A	N/A	N/A	212	215	211	187	192	188
66	53.0	138.2	115.2	115.2	434	340	342	N/A	N/A	N/A	302	230	224	252	206	201
72	57.0	138.2	122.8	122.8	434	361	364	N/A	N/A	N/A	302	246	237	252	213	210
78	62.0	153.5	153.5	153.5	469	476	482	N/A	N/A	N/A	323	312	312	278	284	277
84	68.0	168.9	168.9	168.9	504	516	524	N/A	N/A	N/A	344	332	336	304	312	308
90	72.0	176.6	176.6	176.6	527	537	543	N/A	N/A	N/A	360	354	352	314	323	316
96	76.0	184.3	184.3	184.3	550	558	562	N/A	N/A	N/A	376	376	368	324	334	324
108	84.0	199.6	199.6	199.6	588	596	600	N/A	N/A	N/A	402	402	404	346	372	352
120	98.0	215	215	-	638	642	-	N/A	N/A	-	430	422	-	384	376	-
132	106	230.3	230.3	-	591	595	-	N/A	N/A	-	460	448	-	412	402	-
138	111	245.7	245.7	-	631	637	-	N/A	N/A	-	492	474	-	426	420	-
144	115	245.7	245.7	-	631	637	-	N/A	N/A	-	492	474	-	426	420	-
162	130	307.1	307.1	-	830	833	-	N/A	N/A	-	617	615	-	564	540	-
168	131	314.8	314.8	-	851	854	-	N/A	N/A	-	631	624	-	570	552	-
172	140	322.4	322.4	-	872	875	-	N/A	N/A	-	646	637	-	584	565	-
180	144	330.1	330.1	-	893	897	-	972	1029	-	662	650	-	591	574	-
192	152	337.8	337.8	-	914	918	-	994	1052	-	677	663	-	605	587	-
198	160	353.2	353.2	-	955	963	-	1040	1083	-	707	685	-	618	608	-
204	165	360.8	360.8	-	973	981	-	1062	1106	-	722	698	-	632	621	-
216	174	406.9	406.9	-	1128	1133	-	1197	1296	-	818	817	-	750	716	-
228	180	422.2	422.2	-	1170	1175	-	1247	1320	-	846	835	-	762	740	-
240	190	429.9	429.9	-	1190	1198	-	1272	1332	-	860	844	-	768	752	-

\* Creepage distances are based on standard arrester build configurations.



**Spacing requirements**

Figure 4 illustrates a three-phase in-line mounting arrangement. Dimensions C and D reference minimum phase-to-ground and phase-to-phase distances respectively. These dimensions are listed in Table 8.

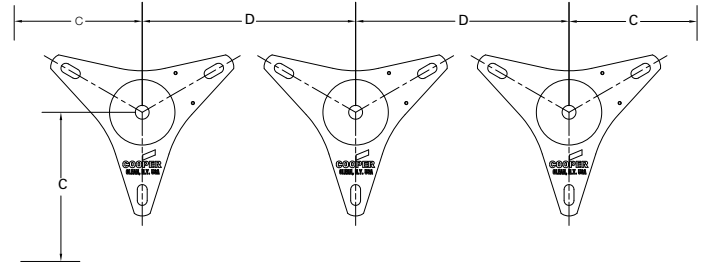

**Figure 4. Three-phase In-line mounting arrangement.**

**Table 8. Dimensions, Clearance Requirements, and Weights of UltraSIL Polymer-Housed Station-Class Arresters (Standard Configuration)**

Arrester Rating (kV, rms)	Arrester MCOV (kV, rms)	Figure 5 Dim. "A" (Inches)			Figure 5 Dim. "B" (Inches)			Figure 4 Dim. "C" Minimum Phase-to-Ground Clearances (inches)*			Figure 4 Dim. "D" Minimum Phase-to-Phase Clearances (inches)*			Weight (lbs.)		
		US	UH	UX	US	UH	UX	US	UH	UX	US	UH	UX	US	UH	UX
3	2.55	8.2	8.2	8.2	5.13	5.49	5.93	5.5	5.5	5.5	10	10	10	8.8	11.0	11.0
6	5.1	9.7	9.7	9.7	5.13	5.49	5.93	5.5	5.5	5.5	10	10	10	8.8	11.0	13.2
9	7.65	9.7	9.7	9.7	5.13	5.49	5.93	5.9	5.6	5.6	10.4	10.1	10.1	8.8	11.0	13.2
10	8.4	9.7	9.7	9.7	5.13	5.49	5.93	6.1	5.8	5.7	10.6	10.3	10.2	8.8	11.0	13.2
12	10.2	11.3	11.3	11.3	5.13	5.49	5.93	6.6	6.2	6	11.1	10.7	10.5	11.0	13.2	15.4
15	12.7	11.3	11.3	11.3	5.13	5.49	5.93	7.5	6.9	6.6	12	11.4	11.1	11.0	13.2	15.4
18	15.3	12.8	12.8	12.8	5.13	5.49	5.93	8.6	7.8	7.4	13.1	12.3	11.9	11.0	13.2	17.6
21	17.0	12.8	12.8	12.8	5.13	5.49	5.93	8.6	7.8	7.4	13.1	12.3	11.9	11.0	13.2	17.6
24	19.5	14.4	14.4	14.4	5.13	5.49	5.93	9.5	8.5	8	14	13	12.5	13.2	15.4	19.8
27	22.0	14.4	14.4	14.4	5.13	5.49	5.93	10.5	9.4	8.8	15	13.9	13.3	13.2	15.4	19.8
30	24.4	16	16	16	5.13	5.49	5.93	11.5	10.2	9.6	16	14.7	14.1	13.2	17.6	22.0
33	27.5	16	16	16	5.13	5.49	5.93	12.7	11.3	10.6	17.2	15.8	15.1	13.2	17.6	22.0
36	29.0	16	16	16	5.13	5.49	5.93	13.3	11.8	11.1	17.8	16.3	15.6	13.2	17.6	22.0
39	31.5	19.1	19.1	19.1	5.13	5.49	5.93	14.3	12.7	11.9	18.8	17.2	16.4	15.4	19.8	26.5
42	34.0	19.1	19.1	19.1	5.13	5.49	5.93	15.2	13.5	12.7	19.7	18	17.2	15.4	19.8	26.5
45	36.5	20.6	20.6	20.6	5.13	5.49	5.93	16.2	14.4	13.5	20.7	18.9	18	17.6	22.0	26.5
48	39.0	22.2	22.2	22.2	5.13	5.49	5.93	17.2	15.3	14.3	21.7	19.8	18.8	17.6	22.0	28.7
54	42.0	22.2	22.2	22.2	5.13	5.49	5.93	18.4	16.3	15.2	22.9	20.8	19.7	17.6	22.0	28.7
60	48.0	23.7	23.7	23.7	5.13	5.49	5.93	20.8	18.4	17.2	25.3	22.9	21.7	19.8	24.3	30.9
66	53.0	30	25.3	25.3	5.13	5.49	5.93	22.7	20.1	18.7	27.2	24.6	23.2	22.0	24.3	33.1
72	57.0	30	26.8	26.8	5.13	5.49	5.93	24.3	21.5	20	28.8	26	24.5	22.0	26.5	35.3
78	62.0	33.2	33.2	33.2	5.13	5.49	5.93	26.3	23.2	21.6	30.8	27.7	26.1	24.3	30.9	41.9
84	68.0	36.3	36.3	36.3	5.13	5.49	5.93	28.7	25.3	23.5	33.2	29.8	28	24.3	33.1	44.1
90	72.0	37.8	37.8	37.8	5.13	5.49	5.93	30.2	26.6	24.8	34.7	31.1	29.3	26.5	35.3	46.3
96	76.0	39.3	39.3	39.3	5.13	5.49	5.93	31.8	28	26.1	36.3	32.5	30.6	26.5	35.3	48.5
108	84.0	42.5	42.5	42.5	5.13	5.49	5.93	35	30.8	28.7	39.5	35.3	33.2	28.7	37.5	52.9
120	98.0	45.6	45.6	-	5.49	5.93	-	35.6	33.1	-	40.1	37.6	-	41.9	57.3	-
132	106	48.7	48.7	-	5.49	5.93	-	46.9	44.2	-	59.9	57.2	-	48.5	66.1	-
138	111	51.8	51.8	-	5.49	5.93	-	48.6	45.8	-	61.6	58.8	-	50.7	68.3	-
144	115	51.8	51.8	-	5.49	5.93	-	50	47.1	-	63	60.1	-	50.7	68.3	-
162	130	68.3	68.3	-	5.49	5.93	-	55.2	51.8	-	68.2	64.8	-	59.5	81.6	-
168	131	69.8	69.8	-	5.49	5.93	-	55.5	52.2	-	68.5	65.2	-	61.7	83.8	-
172	140	71.4	71.4	-	5.49	5.93	-	58.6	55	-	71.6	68	-	63.9	86.0	-
180	144	72.9	72.9	-	5.49	5.93	-	60	56.3	-	73	69.3	-	63.9	88.2	-
192	152	74.5	74.5	-	5.49	5.93	-	62.7	58.9	-	75.7	71.9	-	66.1	90.4	-
198	160	77.6	77.6	-	5.49	5.93	-	65.5	61.4	-	78.5	74.4	-	68.3	92.6	-
204	165	79.2	79.2	-	5.49	5.93	-	67.2	63	-	80.2	76	-	70.5	94.8	-
216	174	88.6	88.6	-	5.49	5.93	-	70.3	65.9	-	83.3	78.9	-	77.2	105.8	-
228	180	91.7	91.7	-	5.49	5.93	-	73.1	68.5	-	86.1	81.5	-	79.4	108.0	-
240	190	93.2	93.2	-	5.49	5.93	-	75.8	71	-	88.8	84	-	81.6	112.4	-

\* Phase-to-Ground clearances are expressed as minimum arrester centerline-to-ground distances. Phase-to-Phase clearances are expressed as minimum arrester centerline-to-centerline distances.

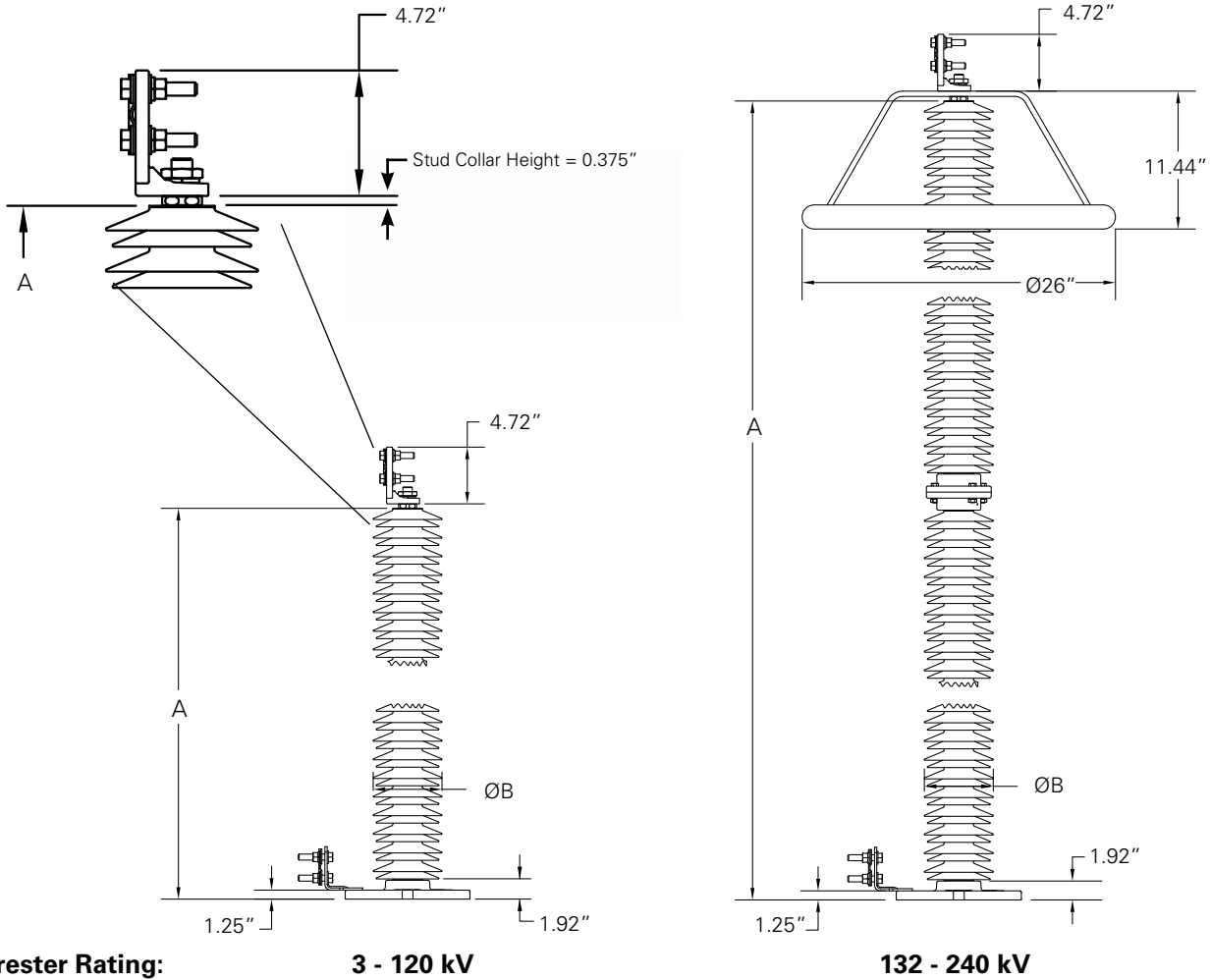

Figure 5. Outline drawing of standard UltraSIL Polymer-Housed Station-Class Arresters (for standard catalog numbers see Table 9).

Table 9 Catalog Numbers for Standard Configuration Type US, UH, and UX Surge Arresters

Arrester Rating (kV, rms)	US	UH	UX	Arrester Rating (kV, rms)	US	UH	UX
3	USAA003002A0845A11	UHAA003002A0845A11	UXAA003002A0845A11	72	USAA072057A3645A11	UHAA072057A3245A11	UXAA072057A3245A11
6	USAA006005A1045A11	UHAA006005A1045A11	UXAA006005A1045A11	78	USAA078062A4045A11	UHAA078062A4045A11	UXAA078062A4045A11
9	USAA009007A1045A11	UHAA009007A1045A11	UXAA009007A1045A11	84	USAA084068A4445A11	UHAA084068A4445A11	UXAA084068A4445A11
10	USAA010008A1045A11	UHAA010008A1045A11	UXAA010008A1045A11	90	USAA090072A4645A11	UHAA090072A4645A11	UXAA090072A4645A11
12	USAA012010A1245A11	UHAA012010A1245A11	UXAA012010A1245A11	96	USAA096076A4845A11	UHAA096076A4845A11	UXAA096076A4845A11
15	USAA015012A1245A11	UHAA015012A1245A11	UXAA015012A1245A11	108	USAA108084A5245A11	UHAA108084A5245A11	UXAA108084A5245A11
18	USAA018015A1445A11	UHAA018015A1445A11	UXAA018015A1445A11	120	USAA120098A5645A11	UHAA120098A5645A11	UXAA120098A5645A11
21	USAA021017A1445A11	UHAA021017A1445A11	UXAA021017A1445A11	132	USAA132106A6045A11	UHAA132106A6045A11	UXAA132106A6045A11
24	USAA024019A1645A11	UHAA024019A1645A11	UXAA024019A1645A11	138	USAA138111A6445A11	UHAA138111A6445A11	UXAA138111A6445A11
27	USAA027022A1645A11	UHAA027022A1645A11	UXAA027022A1645A11	144	USAA144115A6445A11	UHAA144115A6445A11	UXAA144115A6445A11
30	USAA030024A1845A11	UHAA030024A1845A11	UXAA030024A1845A11	162	USAA162130A8045A11	UHAA162130A8045A11	UXAA162130A8045A11
33	USAA033027A1845A11	UHAA033027A1845A11	UXAA033027A1845A11	168	USAA168131A8245A11	UHAA168131A8245A11	UXAA168131A8245A11
36	USAA036029A1845A11	UHAA036029A1845A11	UXAA036029A1845A11	172	USAA172140A8445A11	UHAA172140A8445A11	UXAA172140A8445A11
39	USAA039031A2245A11	UHAA039031A2245A11	UXAA039031A2245A11	180	USAA180144A8645A11	UHAA180144A8645A11	UXAA180144A8645A11
42	USAA042034A2245A11	UHAA042034A2245A11	UXAA042034A2245A11	192	USAA192152A8845A11	UHAA192152A8845A11	UXAA192152A8845A11
45	USAA045036A2445A11	UHAA045036A2445A11	UXAA045036A2445A11	198	USAA198160A9245A11	UHAA198160A9245A11	UXAA198160A9245A11
48	USAA048039A2645A11	UHAA048039A2645A11	UXAA048039A2645A11	204	USAA204165A9445A11	UHAA204165A9445A11	UXAA204165A9445A11
54	USAA054042A2645A11	UHAA054042A2645A11	UXAA054042A2645A11	216	USAA216174A645A11	UHAA216174A645A11	UXAA216174A645A11
60	USAA060048A2845A11	UHAA060048A2845A11	UXAA060048A2845A11	228	USAA228180A8045A11	UHAA228180A8045A11	UXAA228180A8045A11
66	USAA066053A3645A11	UHAA066053A3045A11	UXAA066053A3045A11	240	USAA240190A8245A11	UHAA240190A8245A11	UXAA240190A8245A11

**Table 10. UltraQUIK Catalog Numbering System for UltraSIL Polymer-Housed Station-Class Arresters**

1	U	2		3	A	4	A	5		6		7		8		9		10		11	A	12		13		14		15		16		17		18	
---	---	---	--	---	---	---	---	---	--	---	--	---	--	---	--	---	--	----	--	----	---	----	--	----	--	----	--	----	--	----	--	----	--	----	--

**Catalog Number Digits:**

**1 = "U"** (UltraSIL Polymer-Housed Arrester)

**2 =**

S	= Standard Energy Handling
H	= High Energy Handling
X	= Xtra-High Energy Handling

**3 = "A"** Standard Electrical Build

**4 = "A"** Standard Cantilever Strength\*

\* Consult manufacturer for further information regarding additional cantilever strengths.

**5 through 10 = Arrester Rating: Duty-cycle (MCOV)**

<b>003002</b> = 3 kV (2.55 kV)	<b>042034</b> = 42 kV (34.0 kV)	<b>138111</b> = 138 kV (111 kV)
<b>006005</b> = 6 kV (5.1 kV)	<b>045036</b> = 45 kV (36.5 kV)	<b>144115</b> = 144 kV (115 kV)
<b>009007</b> = 9 kV (7.65 kV)	<b>048039</b> = 48 kV (39.0 kV)	<b>162130</b> = 162 kV (130 kV)
<b>010008</b> = 10 kV (8.4 kV)	<b>054042</b> = 54 kV (42.0 kV)	<b>168131</b> = 168 kV (131 kV)
<b>012010</b> = 12 kV (10.2 kV)	<b>060048</b> = 60 kV (48.0 kV)	<b>172140</b> = 172 kV (140 kV)
<b>015012</b> = 15 kV (12.7 kV)	<b>066053</b> = 66 kV (53.0 kV)	<b>180144</b> = 180 kV (144 kV)
<b>018015</b> = 18 kV (15.3 kV)	<b>072057</b> = 72 kV (57.0 kV)	<b>192152</b> = 192 kV (152 kV)
<b>021017</b> = 21 kV (17.0 kV)	<b>078062</b> = 78 kV (62.0 kV)	<b>198160</b> = 198 kV (160 kV)
<b>024019</b> = 24 kV (19.5 kV)	<b>084068</b> = 84 kV (68.0 kV)	<b>204165</b> = 204 kV (165 kV)
<b>027022</b> = 27 kV (22.0 kV)	<b>090072</b> = 90 kV (72.0 kV)	<b>216174</b> = 216 kV (174 kV)
<b>030024</b> = 30 kV (24.4 kV)	<b>096076</b> = 96 kV (76.0 kV)	<b>228180</b> = 228 kV (180 kV)
<b>033027</b> = 33 kV (27.0 kV)	<b>108084</b> = 108 kV (84.0 kV)	<b>240190</b> = 240 kV (190 kV)
<b>036029</b> = 36 kV (29.0 kV)	<b>120098</b> = 120 kV (98.0 kV)	
<b>039031</b> = 39 kV (31.5 kV)	<b>132106</b> = 132 kV (106 kV)	

**11 = "A"** Standard High Creep UltraSIL Polymer-Housing

Table 10. UltraQUIK Catalog Numbering System for UltraSIL Polymer-Housed Station-Class Arresters (continued)

1	U	2		3	A	4	A	5		6		7		8		9		10		11	A	12		13		14		15		16		17		18	
---	---	---	--	---	---	---	---	---	--	---	--	---	--	---	--	---	--	----	--	----	---	----	--	----	--	----	--	----	--	----	--	----	--	----	--

**Catalog Number Digits:**

**12 and 13 = Housing Code** (Select from Table below): \* = Standard Housing (31 mm/kV), 0 = Optional Housing

**Type US Housing Codes**

Digits 12 & 13		08	10	12	14	16	18	20	22	24	26	28	36	40	44	46	48	50	52	54	56	60	64	80	
Arrester Rating (kV rms)	Leakage Distance (in.)	30.7	38.4	46.1	53.7	61.4	69.1	76.8	84.4	92.1	99.8	107.5	138.2	153.5	168.9	176.6	184.3	192	199.6	207.3	215	230.3	245.7	307.1	
	3	*																							
	6		*	0																					
	9		*	0	0																				
	10		*	0	0																				
	12			*	0	0																			
	15			*	0	0	0																		
	18			*	0	0	0	0																	
	21				*	0	0	0	0																
	24				*	0	0	0	0	0															
	27				*	0	0	0	0	0															
	30					*	0	0	0	0	0														
	33					*	0	0	0	0	0														
	36					*	0	0	0	0	0	0													
	39								*	0	0	0													
	42								*	0	0	0													
	45									*	0	0													
	48										*	0													
	54										*	0													
	60											*													
	66												*												
	72													*											
	78														*	0	0	0	0	0	0	0	0	0	0
	84															*	0	0	0	0	0	0	0	0	0
	90																*	0	0	0	0	0	0	0	0
	96																	*	0	0	0	0	0	0	0
	108																			*	0	0	0	0	0
	120																					*	0	0	0
132																						*	0	0	
138																							*	0	
144																								*	
162																								*	
168																									
172																									
180																									
192																									
198																									
204																									
216																									
228																									
240																									
Leakage Distance (in.)		30.7	38.4	46.1	53.7	61.4	69.1	76.8	84.4	92.1	99.7	107.5	138.2	153.5	168.9	176.6	184.3	192	199.6	207.3	215	230.3	245.7	307.1	
Arrester Rating (kV rms)																									
Digits 12 & 13		08	10	12	14	16	18	20	22	24	26	28	36	40	44	46	48	50	52	54	56	60	64	80	

continued on page 13

82	84	86	88	90	92	94	96	98	A0	A4	A6	A8	B0	B2	B4	B6	B8	Digits 12 & 13	Leakage Distance (in.)	Arrester Rating (kV rms)
314.8	322.4	330.1	337.8	345.5	353.2	360.8	368.5	376.2	383.9	399.3	406.9	414.6	422.2	429.9	437.6	445.3	453			3
																				6
																				9
																				10
																				12
																				15
																				18
																				21
																				24
																				27
																				30
																				33
																				36
																				39
																				42
																				45
																				48
																				54
																				60
																				66
																				72
																				78
																				84
																				90
																				96
																				108
																				120
0																				132
0	0																			138
0	0																			144
0	0	0																		162
*	0	0																		168
	*	0																		172
		*																		180
			*	0	0	0	0	0	0	0	0	0	0	0	0	0	0			192
				*	0	0	0	0	0	0	0	0	0	0	0	0	0			198
					*	0	0	0	0	0	0	0	0	0	0	0	0			204
						*	0	0	0	0	0	*	0	0	0	0	0			216
													*	0	0	0	0			228
														*	0	0	0			240
314.8	322.4	330.1	337.8	345.5	353.2	360.8	368.5	376.2	383.9	399.3	406.9	414.6	422.2	429.9	437.6	445.3	453		Leakage Distance (in.)	Arrester Rating (kV rms)
																				Digits 12 & 13

continued from page 12

**Table 10. UltraQUIK Catalog Numbering System for UltraSIL Polymer-Housed Station-Class Arresters (continued)**

1	U	2		3	A	4	A	5		6		7		8		9		10		11	A	12		13		14		15		16		17		18	
---	---	---	--	---	---	---	---	---	--	---	--	---	--	---	--	---	--	----	--	----	---	----	--	----	--	----	--	----	--	----	--	----	--	----	--

**Catalog Number Digits:**

**12 and 13 = Housing Code** (Select from Table below): \* = Standard Housing (31 mm/kV), 0 = Optional Housing

**Type UH Housing Codes**

Digits 12 & 13	08	10	12	14	16	18	20	22	24	26	28	30	32	36	40	44	46	48	50	52	54	56	58
Leakage Distance (in.)	30.7	38.4	46.1	53.7	61.4	69.1	76.8	84.4	92.1	99.8	107.5	115.2	122.8	138.2	153.5	168.9	176.6	184.3	192	199.6	207.3	215	222.7
Arrester Rating (kV rms)																							
3	*																						
6		*	0																				
9		*	0	0																			
10		*	0	0																			
12			*	0	0																		
15			*	0	0	0																	
18			*	0	0	0	0																
21			*	0	0	0	0	0															
24				*	0	0	0	0	0														
27				*	0	0	0	0	0														
30					*	0	0	0	0	0													
33					*	0	0	0	0	0													
36					*	0	0	0	0	0	0												
39								*	0	0	0	0											
42								*	0	0	0	0											
45									*	0	0	0											
48										*	0	0											
54										*	0	0											
60											*	0											
66											*	0	0	0									
72												*	0	0	0	0	0	0	0				
78														*	0	0	0	0	0	0	0		
84															*	0	0	0	0	0	0		
90																*	0	0	0	0	0	0	0
96																	*	0	0	0	0	0	0
108																		*					0
120																				*			0
132																							
138																							
144																							
162																							
168																							
172																							
180																							
192																							
198																							
204																							
216																							
228																							
240																							
Leakage Distance (in.)	30.7	38.4	46.1	53.7	61.4	69.1	76.8	84.4	92.1	99.7	107.5	138.2	153.5	168.9	176.6	184.3	192	199.6	207.3	215	230.3	245.7	307.1
Arrester Rating (kV rms)																							
Digits 12 & 13	08	10	12	14	16	18	20	22	24	26	28	36	40	44	46	48	50	52	54	56	60	64	80

continued on page 15

60	64	80	82	84	86	88	90	92	94	96	98	A0	A4	A6	A8	B0	B2	B4	B6	B8	C0	Digits 12 & 13	
230.3	245.7	307.1	314.8	322.4	330.1	337.8	345.5	353.2	360.8	368.5	376.2	383.9	399.3	406.9	414.6	422.2	429.9	437.6	445.3	453	460.7	Leakage Distance (in.)	
																						Arrester Rating (kV rms)	
																						3	
																							6
																							9
																							10
																							12
																							15
																							18
																							21
																							24
																							27
																							30
																							33
																							36
																							39
																							42
																							45
																							48
																							54
																							60
																							66
																							72
																							78
																							84
																							90
																							96
0																							108
0																							120
*	0	0	0																				132
*	0	0	0	0																			138
*	0	0	0	0																			144
	*	0	0	0	0	0																	162
		*	0	0	0	0	0																168
			*	0	0	0	0																172
				*	0	0	0																180
					*	0	0	0	0	0	0	0	0	0	0	0	0	0	0	0	0		192
						*	0	0	0	0	0	0	0	0	0	0	0	0	0	0	0		198
							*	0	0	0	0	0	0	0	0	0	0	0	0	0	0		204
								*	0	0	0	0	0	0	0	0	0	0	0	0	0		216
									*	0	0	0	0	0	0	0	0	0	0	0	0		228
										*	0	0	0	0	0	0	0	0	0	0	0		240
230.3	245.7	307.1	314.8	322.4	330.1	337.8	345.5	353.2	360.8	368.5	376.2	383.9	399.3	406.9	414.6	422.2	429.9	437.6	445.3	453	460.7	Leakage Distance (in.)	
																						Arrester Rating (kV rms)	
																							Digits 12 & 13

continued from page 14

**Table 10. UltraQUIK Catalog Numbering System for UltraSIL Polymer-Housed Station-Class Arresters (continued)**

1	U	2		3	A	4	A	5		6		7		8		9		10		11	A	12		13		14		15		16		17		18	
---	---	---	--	---	---	---	---	---	--	---	--	---	--	---	--	---	--	----	--	----	---	----	--	----	--	----	--	----	--	----	--	----	--	----	--

**Catalog Number Digits:**

**12 and 13 = Housing Code** (Select from Table below): \* = Standard Housing (31 mm/kV), 0 = Optional Housing

**Type UX Housing Codes**

Digits 12 & 13	08	10	12	14	16	18	20	22	24	26	28	30	32	36	40	44	46	48	50	52	54	56	58	60
Leakage Distance (in.)	30.7	38.4	46.1	53.7	61.4	69.1	76.8	84.4	92.1	99.8	107.5	115.2	122.8	138.2	153.5	168.9	176.6	184.3	192	199.6	207.3	215	222.7	230.3
Arrester Rating (kV rms)																								
3	*																							
6		*	0																					
9		*	0	0																				
10		*	0	0																				
12			*	0	0																			
15				*	0	0	0																	
18				*	0	0	0	0																
21				*	0	0	0	0	0															
24					*	0	0	0	0															
27					*	0	0	0	0															
30						*	0	0	0	0														
33						*	0	0	0	0														
36						*	0	0	0	0	0													
39								*	0	0	0	0												
42								*	0	0	0	0												
45									*	0	0	0												
48										*	0	0												
54											*	0	0											
60												*	0											
66												*	0	0	0									
72													*	0	0	0	0	0	0					
78															*	0	0	0	0	0	0	0		
84																*	0	0	0	0	0	0		
90																	*		0	0	0	0	0	
96																		*	0	0	0	0	0	0
108																			*	0	0	0	0	0
Leakage Distance (in.)	30.7	38.4	46.1	53.7	61.4	69.1	76.8	84.4	92.1	99.8	107.5	115.2	122.8	138.2	153.5	168.9	176.6	184.3	192	199.6	207.3	215	222.7	230.3
Arrester Rating (kV rms)																								
Digits 12 & 13	08	10	12	14	16	18	20	22	24	26	28	30	32	36	40	44	46	48	50	52	54	56	58	60

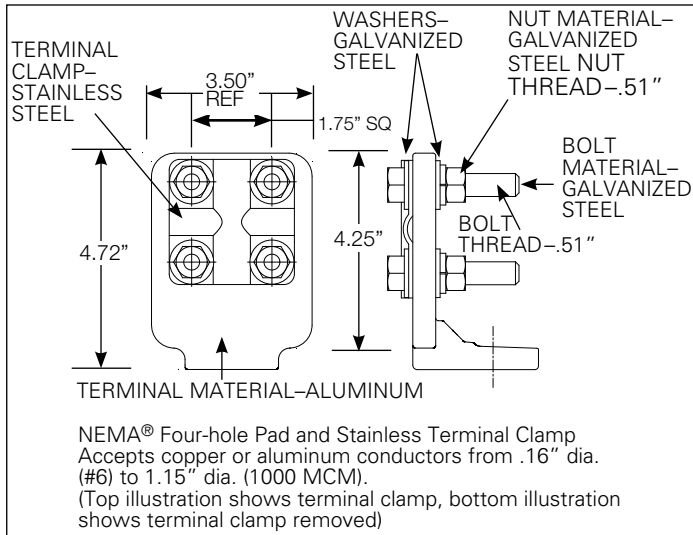

Table 10. UltraQUIK Catalog Numbering System for UltraSIL Polymer-Housed Station-Class Arresters (continued)

1	2	3	4	5	6	7	8	9	10	11	12	13	14	15	16	17	18
U		A	A							A							

14 = Line Terminal Options

**Standard Offering-Select 4**



**Optional Offering-Select A**

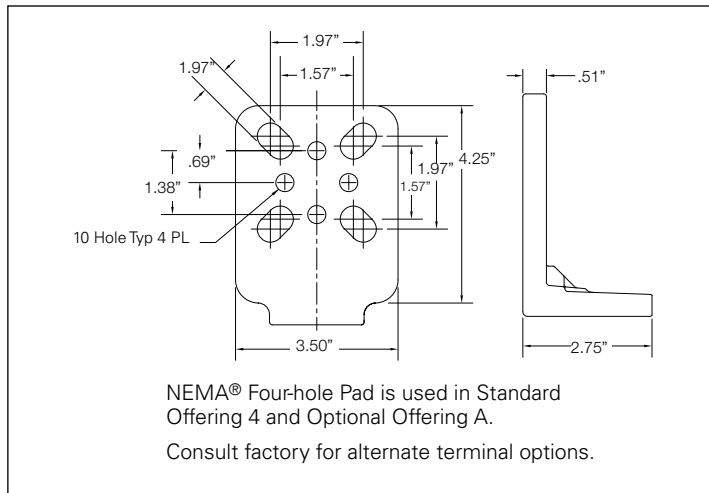
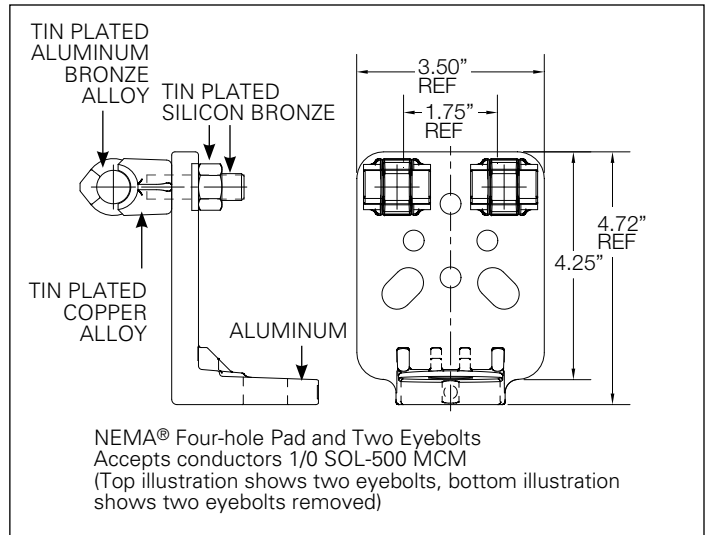

**Optional Offering-Select 1**

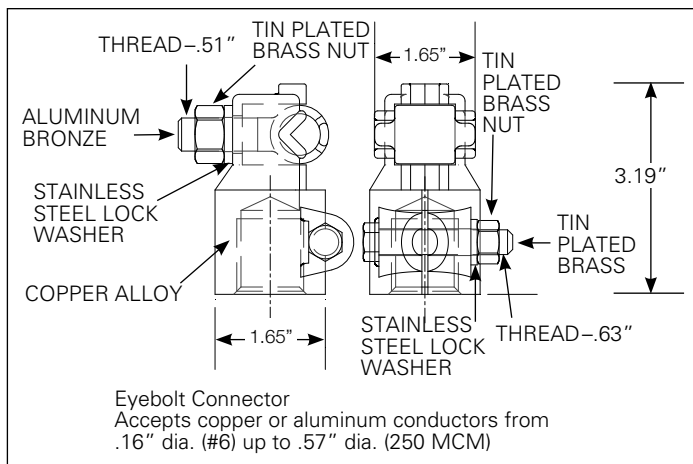

**Optional Offering-Select 5**

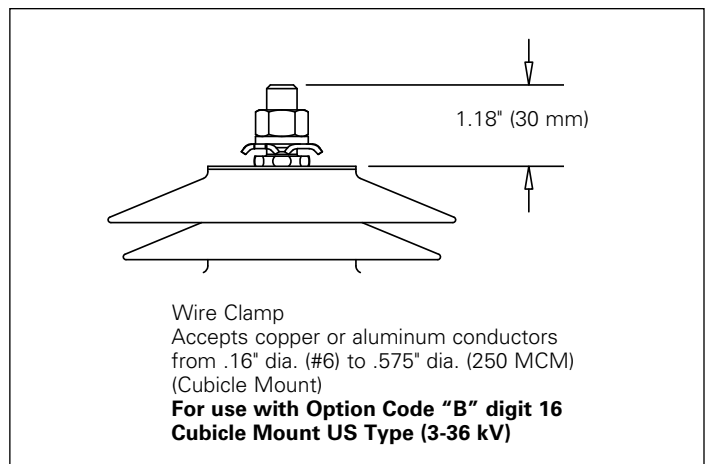
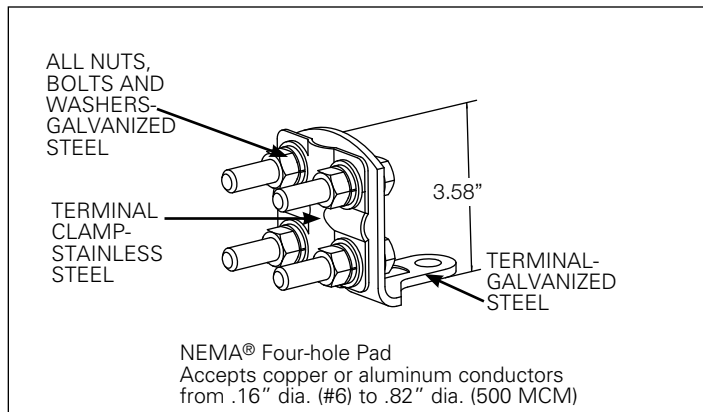

**Table 10. UltraQUIK Catalog Numbering System for UltraSIL Polymer-Housed Station-Class Arresters (continued)**

1	U	2	3	A	4	A	5	6	7	8	9	10	11	A	12	13	14	15	16	17	18
---	---	---	---	---	---	---	---	---	---	---	---	----	----	---	----	----	----	----	----	----	----

**15 = Earth Terminal Options**

**Standard Offering-Select 5**



**Optional Offering-Select 1**

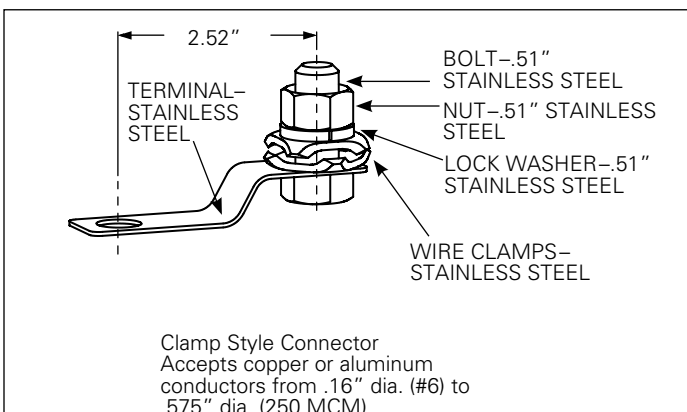

**Optional Offering-Select 9**

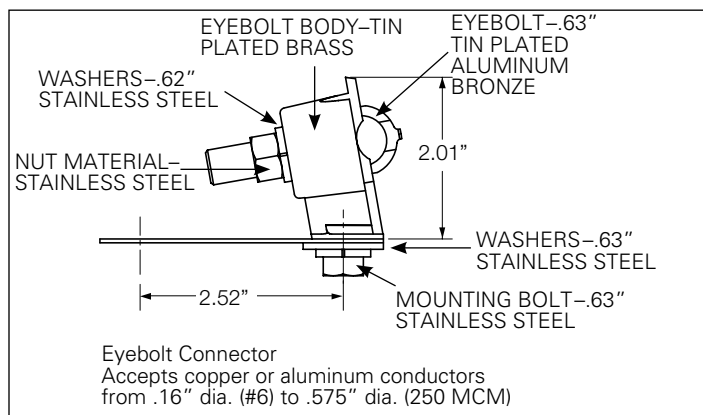

**Optional Offering-Select B**

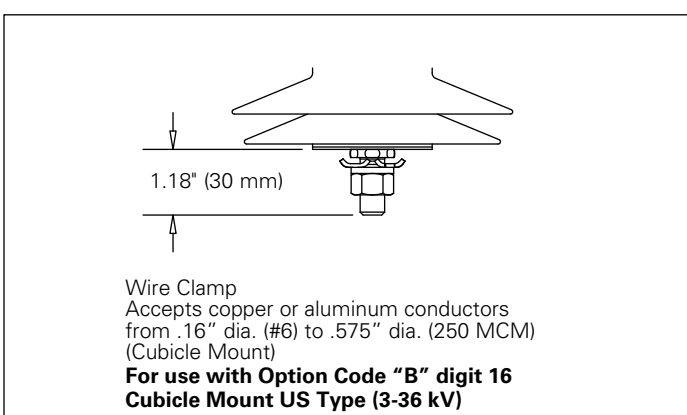

**16 = Mounting Arrangement**

**Standard Offering-Select A**

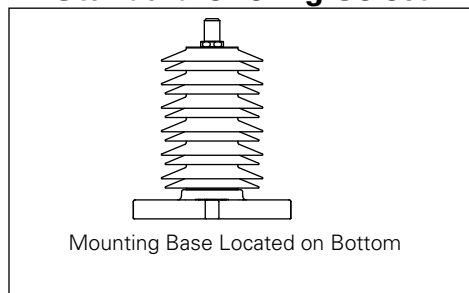

**Optional-Select B**

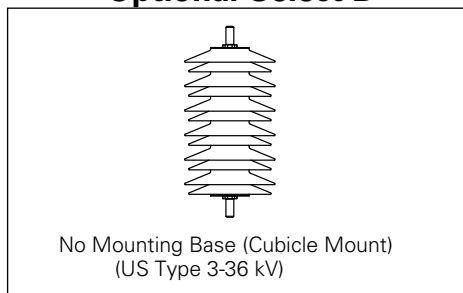

**Optional-Select C**

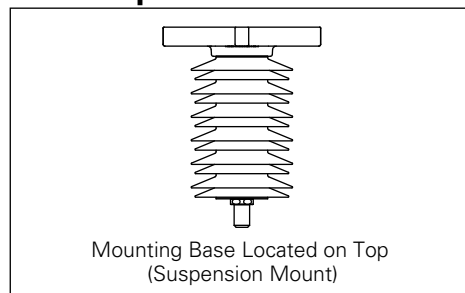

**17 = "1"** - Nameplate for Standard or Suspension Mount

"2" - Nameplate for Cubicle Mount (US Type 3-36 kV) Option Code "B" for digit 16

**18 = "1"** - Cardboard Packaging

"2" - Wood Crate Packaging

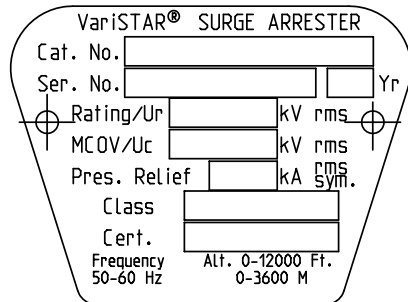

Figure 6. Detail of base nameplate.

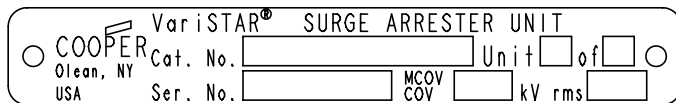

Figure 7. Detail of unit nameplate on base of arrester section.

## Nameplate information

A stainless steel nameplate is attached to the base of every UltraSIL Polymer-Housed Type US, UH, and UX Arrester. The arrester catalog number, serial number, year of manufacture, duty-cycle rating, MCOV ratings, and pressure relief rating are among the details provided on the nameplate. For multi-unit arresters above 120 kV, an additional unit nameplate is provided on the base of the arrester unit section as shown in Figure 7. See Figure 6 for an example of a base nameplate.

## Additional information

- S235-103-1 UltraSIL Polymer-Housed VariSTAR Station-Class Surge Arrester Installation and Maintenance Instructions.
- CP1122 UltraSIL Polymer-Housed VariSTAR Type US, UH, and UX Station-Class Surge Arresters Certified Test Report.

**Eaton**  
1000 Eaton Boulevard  
Cleveland, OH 44122  
United States  
Eaton.com

**Eaton's Cooper Power Systems Division**  
2300 Badger Drive  
Waukesha, WI 53188  
United States  
Eaton.com/cooperpowerseries

© 2015 Eaton  
All Rights Reserved  
Printed in USA  
Publication No. CA235013EN

Eaton is a registered trademark.

All other trademarks are property  
of their respective owners.

For Eaton's Cooper Power series product  
information call 1-877-277-4636 or visit:  
[www.eaton.com/cooperpowerseries](http://www.eaton.com/cooperpowerseries).