

Two- and three-phase MagneX™ interrupter installation instructions



EATON

Powering Business Worldwide

DISCLAIMER OF WARRANTIES AND LIMITATION OF LIABILITY

The information, recommendations, descriptions and safety notations in this document are based on Eaton Corporation's ("Eaton") experience and judgment and may not cover all contingencies. If further information is required, an Eaton sales office should be consulted. Sale of the product shown in this literature is subject to the terms and conditions outlined in appropriate Eaton selling policies or other contractual agreement between Eaton and the purchaser.

THERE ARE NO UNDERSTANDINGS, AGREEMENTS, WARRANTIES, EXPRESSED OR IMPLIED, INCLUDING WARRANTIES OF FITNESS FOR A PARTICULAR PURPOSE OR MERCHANTABILITY, OTHER THAN THOSE SPECIFICALLY SET OUT IN ANY EXISTING CONTRACT BETWEEN THE PARTIES. ANY SUCH CONTRACT STATES THE ENTIRE OBLIGATION OF EATON. THE CONTENTS OF THIS DOCUMENT SHALL NOT BECOME PART OF OR MODIFY ANY CONTRACT BETWEEN THE PARTIES.

In no event will Eaton be responsible to the purchaser or user in contract, in tort (including negligence), strict liability or otherwise for any special, indirect, incidental or consequential damage or loss whatsoever, including but not limited to damage or loss of use of equipment, plant or power system, cost of capital, loss of power, additional expenses in the use of existing power facilities, or claims against the purchaser or user by its customers resulting from the use of the information, recommendations and descriptions contained herein. The information contained in this manual is subject to change without notice.

Contents

SAFETY INFORMATION	
Safety Information	iv
PRODUCT INFORMATION	
Introduction	1
Acceptance and Initial Inspection.....	1
Handling and Storage	1
Quality Standards.....	1
ELECTRICAL RATINGS	
Voltage Ratings	1
Interrupting Rating	1
APPLICATION/OPERATION	
Application/Operation	2
OPERATION REQUIREMENTS	
Operation Requirements	2
INSTALLATION	
Installation Instructions.....	2
RECOMMENDED CLEARANCES	
Mechanical	5
Dielectric.....	5
MECHANICAL STRENGTH	
Strip Point of Housing Threads.....	6
Decal.....	6



Safety for life



Eaton meets or exceeds all applicable industry standards relating to product safety in its Cooper Power™ series products. We actively promote safe practices in the use and maintenance of our products through our service literature, instructional training programs, and the continuous efforts of all Eaton employees involved in product design, manufacture, marketing, and service.

We strongly urge that you always follow all locally approved safety procedures and safety instructions when working around high voltage lines and equipment, and support our “Safety For Life” mission.

Safety information

The instructions in this manual are not intended as a substitute for proper training or adequate experience in the safe operation of the equipment described. Only competent technicians who are familiar with this equipment should install, operate, and service it.

A competent technician has these qualifications:

- Is thoroughly familiar with these instructions.
- Is trained in industry-accepted high and low-voltage safe operating practices and procedures.
- Is trained and authorized to energize, de-energize, clear, and ground power distribution equipment.
- Is trained in the care and use of protective equipment such as arc flash clothing, safety glasses, face shield, hard hat, rubber gloves, clampstick, hotstick, etc.

Following is important safety information. For safe installation and operation of this equipment, be sure to read and understand all cautions and warnings.

Hazard Statement Definitions

This manual may contain four types of hazard statements:

DANGER

Indicates an imminently hazardous situation which, if not avoided, will result in death or serious injury.

WARNING

Indicates a potentially hazardous situation which, if not avoided, could result in death or serious injury.

CAUTION

Indicates a potentially hazardous situation which, if not avoided, may result in minor or moderate injury.

CAUTION: Indicates a potentially hazardous situation which, if not avoided, may result in equipment damage only.

Safety instructions

Following are general caution and warning statements that apply to this equipment. Additional statements, related to specific tasks and procedures, are located throughout the manual.

DANGER

Hazardous voltage. Contact with hazardous voltage will cause death or severe personal injury. Follow all locally approved safety procedures when working around high- and low-voltage lines and equipment.

G103.3

WARNING

Before installing, operating, maintaining, or testing this equipment, carefully read and understand the contents of this manual. Improper operation, handling or maintenance can result in death, severe personal injury, and equipment damage.

G101.0

WARNING

This equipment is not intended to protect human life. Follow all locally approved procedures and safety practices when installing or operating this equipment. Failure to comply can result in death, severe personal injury and equipment damage.

G102.1

WARNING

Power distribution and transmission equipment must be properly selected for the intended application. It must be installed and serviced by competent personnel who have been trained and understand proper safety procedures. These instructions are written for such personnel and are not a substitute for adequate training and experience in safety procedures. Failure to properly select, install or maintain power distribution and transmission equipment can result in death, severe personal injury, and equipment damage.

G122.3



CAUTION

The MagneX™ interrupter is designed to be operated in accordance with normal safe operating procedures. These instructions are not intended to supersede or replace existing safety and operating procedures.

Read all instructions before installing the MagneX™ interrupter.

The fuse should be installed and serviced only by personnel familiar with good safety practice and the handling of high-voltage electrical equipment.

Product information

Introduction

Eaton designs its Cooper Power™ series MagneX™ interrupter to be an over-current protective device that protects distribution transformers from damaging overloads and secondary faults, and is also used for switching the transformer “on” or “off”.

Read this manual first

Read and understand the contents of this manual and follow all locally approved procedures and safety practices before installing or operating this equipment.

Additional information

These instructions cannot cover all details or variations in the equipment, procedures, or process described nor provide directions for meeting every possible contingency during installation, operation, or maintenance. For additional information, contact your representative.

Acceptance and initial inspection

Each MagneX interrupter is in good condition when accepted by the carrier for shipment. Upon receipt, inspect the shipping container for signs of damage. Unpack the MagneX interrupter and inspect it thoroughly for damage incurred during shipment. If damage is discovered, file a claim with the carrier immediately.

Handling and storage

Be careful during handling and storage of the MagneX interrupter to minimize the possibility of damage. If the MagneX interrupter is to be stored for any length of time prior to installation, provide a clean, dry storage area.

Standards

ISO 9001 Certified Quality Management System

Electrical ratings

Table 1. Voltage Ratings and Characteristics

	kV	Amps
Impulse 1.2 x 50 Microsecond Wave	150	–
60 Hz, 1 Minute Voltage Withstand	50	–
Continuous Current Rating	–	42
Switching Load Currents	–	42

Table 2. Interrupting Rating

Voltage kV-LG (A)	RMS Symmetric (A)	RMS Asymmetric (A)
8.3	2800	4200
15.5	1500	2250
23.0	500	750

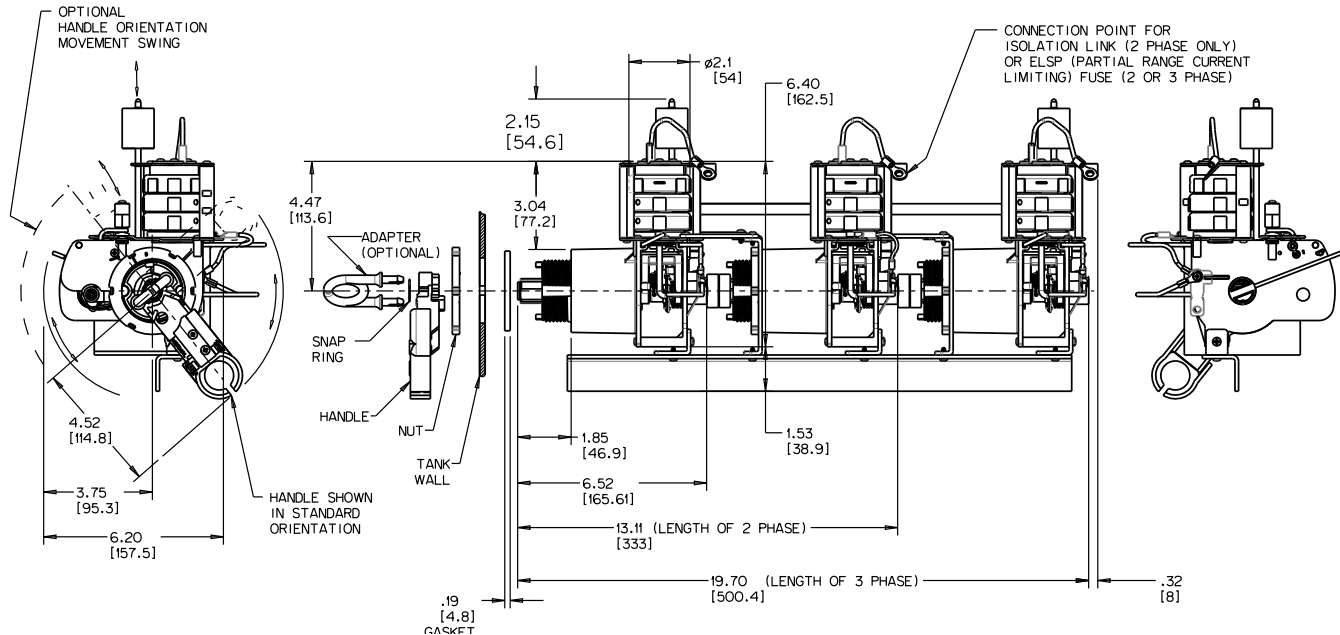

Figure 1. MagneX assembly – front/side/back views (with standard handle hardware kit).

Note: Dimensions given are for reference only, inches (mm)

Application/operation

The MagneX Interrupter is a primary loadbreak interrupting device, which is handle operated only. Handle operation must be performed with an operating tool, such as a hotstick, hookstick or disconnect stick. When the handle is down against its physical stop, the contacts are “closed” (standard position). Rotating the handle upward (counter clockwise) causes the spring loaded contacts to “open.” Moving the handle downward against its physical stop returns the device to the “closed” position. (Refer to Figure 2).

Note: With handle reversed 180° (optional orientation), when the handle is up against its physical stop, the contacts are “closed.” Rotating the handle downward (counter clockwise) causes the spring loaded contacts to “open.” Moving the handle upward (clockwise) against its physical stop returns the device to the “closed” position.

In the “closed” position, this device will operate automatically due to an overcurrent condition or rise in oil temperature. In this case, the circuit will be “open,” with the handle pointed downward in the “closed” (standard position). To reset, the handle must be rotated upward (counter clockwise) to the “open” position and then back down (clockwise) against its physical stop to the “closed” position. (Refer to Figure 2).

Note: To reset with handle reversed 180° (optional orientation), repeat the remainder of note above.

CAUTION

Because the three-phase MagneX interrupter can only gang trip and reset (all phases at one time). It can only be used for delta applications/transformers.

Operation requirements

CAUTION

The MagneX interrupter must be used with an isolation link or current-limiting fuse.

This prevents the primary circuit from being energized in the event of a faulted transformer.

Installation

The two- or three-phase MagneX interrupter is mounted through the transformer tank wall for side wall mount. Use 2.25" diameter hole size with anti-rotation nibs (.156" radius), refer to Figure 3. Nibs (either one or two) must be on the horizontal centerline of the tank hole ± 5 degrees. Refer to Figures 4 and 5 to see how the unit should be installed and connected. The oil level should be 2" (minimum) above top of chamber. Sealing is accomplished with gasket on inside of tank and sealing nut on protruding threads through tank wall.

The MagneX interrupter should be kept perpendicular with the tank wall during installation (through the tank wall mounting hole from the inside of the tank). This may require some type of support (inside tank) until the sealing nut is snug up against the tank wall. The sealing nut shall be tightened to snug plus 1/2 turn, (90-120 in-lbs, 10-14 Nm).

Note: Snug is defined as the point at which the sealing nut no longer turns freely as the MagneX interrupter is supported.

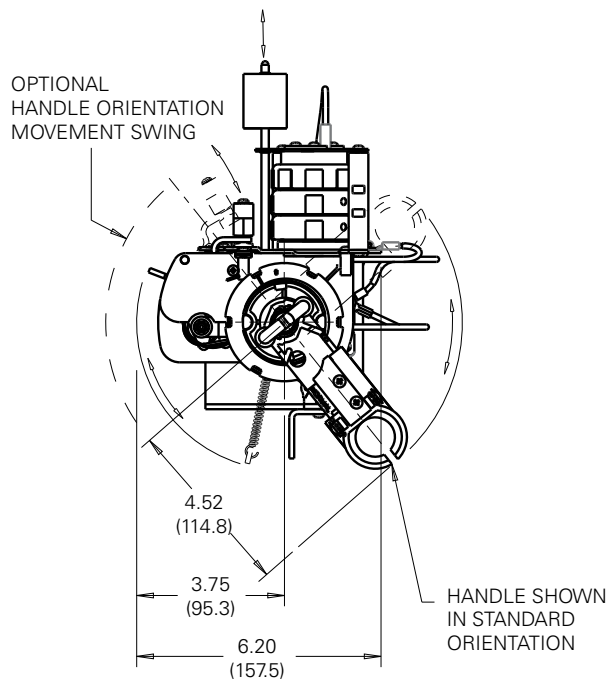

Figure 2. Open/Closed handle positions (Standard positions shown).

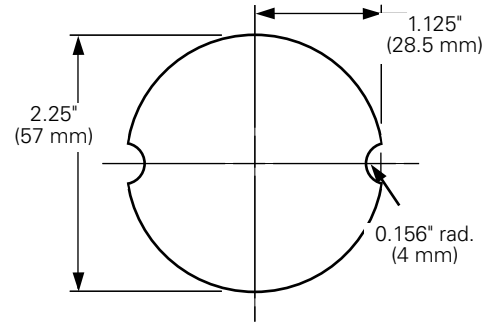

Figure 3. Tank mounting hole detail.

Note: Exterior mounting surface extending 1/2" outward from the tank hole outer edge shall be flat and clear of surface obstructions.

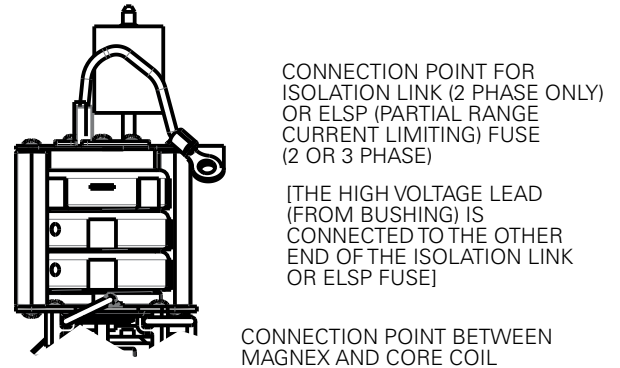

Figure 4. Lead connection points.

Recommended clearances

Mechanical

- External handle clear of obstruction. Clearances also required for handle movement swing. (Refer to Figure 2).

Dielectric (under-oil)

- Clouds of gas will rise during operation, so it is not recommended that other components be located above the MagneX interrupter, unless they are outside the arc clearance zone and have an insulated barrier between them that will deflect gas bubbles from the MagneX operation away from the component above the MagneX interrupter.

The outline drawings shown in Figures 5 and 6 describe the MagneX interrupter and its application in oil-filled apparatus. This information should be used only by trained personnel familiar with the design requirements for oil-filled apparatus. This information is not intended as a substitute for adequate training and experience in such design. Should clarification or further information be required for the user's purposes, contact your Eaton representative.

All energized parts of the MagneX interrupter must be under oil and spaced away from other energized parts or ground with sufficient distance to withstand all operating and test voltages. In order for proper switch operation to occur, an arc clearance zone is required around the MagneX interrupter. This zone should be under oil and free of all foreign materials. The boundaries of this zone are defined in Figure 5.

CAUTION

Recommended (minimum) under-oil clearances must be followed to avoid internal arcing which could result in component failure, property damage or possible severe personal injury.

Mechanical strength

Strip point of housing threads

The torque strength of the sealing nut and housing threads exceeds 400 in-lbs (45 Nm). This device requires no additional bracing or support, as it is fully self-supporting. The mechanical strength of the device exceeds the maximum stress from leads or interrupting functions.

Decal

A "Caution Decal" and "Warning Decal" are included and should be located on the tank wall near the Magnex interrupter handle. (Failure to do so will constitute a waiver of all warranty and indemnity obligations attributed to Eaton).

This page is intentionally left blank.

This page is intentionally left blank.



Eaton
1000 Eaton Boulevard
Cleveland, OH 44122
United States
Eaton.com

**Eaton's Cooper Power Systems
Division**
2300 Badger Drive
Waukesha, WI 53188
United States
Eaton.com/cooperpowerseries

© 2015 Eaton
All Rights Reserved
Printed in USA
Publication No. MN132005EN Rev 0
(Supersedes 5000050900 Rev 1)

Eaton, Cooper Power, and MagneX are
valuable trademarks of Eaton in the U.S.
and other countries. You are not permitted
to use these trademarks without the prior
written consent of Eaton.

For Eaton's Cooper Power series MagneX
interrupter product information
call 1-877-277-4636 or visit:
www.eaton.com/cooperpowerseries.