

## S.T.A.R. Type ER faulted circuit indicator installation instructions

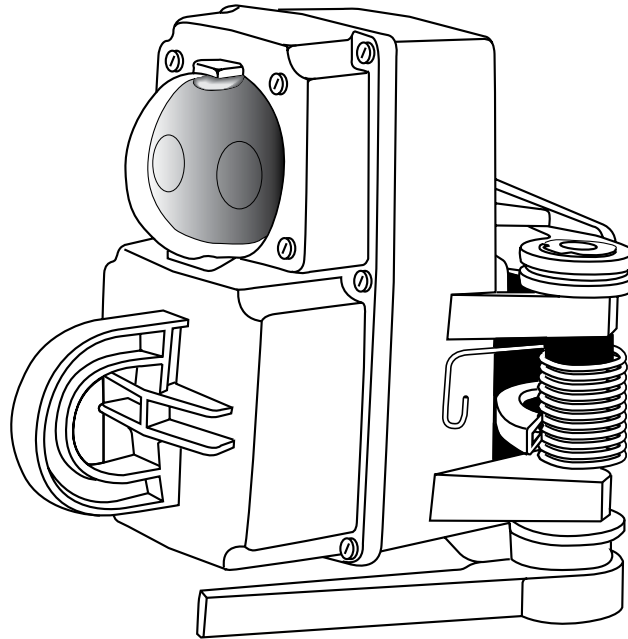

## **DISCLAIMER OF WARRANTIES AND LIMITATION OF LIABILITY**

The information, recommendations, descriptions and safety notations in this document are based on Eaton Corporation's ("Eaton") experience and judgment and may not cover all contingencies. If further information is required, an Eaton sales office should be consulted. Sale of the product shown in this literature is subject to the terms and conditions outlined in appropriate Eaton selling policies or other contractual agreement between Eaton and the purchaser.

THERE ARE NO UNDERSTANDINGS, AGREEMENTS, WARRANTIES, EXPRESSED OR IMPLIED, INCLUDING WARRANTIES OF FITNESS FOR A PARTICULAR PURPOSE OR MERCHANTABILITY, OTHER THAN THOSE SPECIFICALLY SET OUT IN ANY EXISTING CONTRACT BETWEEN THE PARTIES. ANY SUCH CONTRACT STATES THE ENTIRE OBLIGATION OF EATON. THE CONTENTS OF THIS DOCUMENT SHALL NOT BECOME PART OF OR MODIFY ANY CONTRACT BETWEEN THE PARTIES.

In no event will Eaton be responsible to the purchaser or user in contract, in tort (including negligence), strict liability or otherwise for any special, indirect, incidental or consequential damage or loss whatsoever, including but not limited to damage or loss of use of equipment, plant or power system, cost of capital, loss of power, additional expenses in the use of existing power facilities, or claims against the purchaser or user by its customers resulting from the use of the information, recommendations and descriptions contained herein. The information contained in this manual is subject to change without notice.

**Contents**

**DISCLAIMER OF WARRANTIES AND LIMITATION OF LIABILITY . . . . . I**

**SAFETY FOR LIFE . . . . . III**

**SAFETY INFORMATION . . . . . III**  
    Safety instructions . . . . . iii

**PRODUCT INFORMATION . . . . . 1**

**INSTALLATION PROCEDURE . . . . . 2**

**OPERATION INSTRUCTIONS . . . . . 3**



## Safety for life



Eaton's Cooper Power series products meet or exceed all applicable industry standards relating to product safety. We actively promote safe practices in the use and maintenance of our products through our service literature, instructional training programs, and the continuous efforts of all Eaton employees involved in product design, manufacture, marketing and service.

We strongly urge that you always follow all locally approved safety procedures and safety instructions when working around high-voltage lines and equipment and support our "Safety For Life" mission.

## Safety information

The instructions in this manual are not intended as a substitute for proper training or adequate experience in the safe operation of the equipment described. Only competent technicians, who are familiar with this equipment should install, operate and service it.

A competent technician has these qualifications:

- Is thoroughly familiar with these instructions.
- Is trained in industry-accepted high- and low-voltage safe operating practices and procedures.
- Is trained and authorized to energize, de-energize, clear, and ground power distribution equipment.
- Is trained in the care and use of protective equipment such as flash clothing, safety glasses, face shield, hard hat, rubber gloves, hotstick, etc.

Following is important safety information. For safe installation and operation of this equipment, be sure to read and understand all cautions and warnings.

### Hazard Statement Definitions

This manual may contain four types of hazard statements:

#### DANGER

Indicates an imminently hazardous situation which, if not avoided, will result in death or serious injury.

#### WARNING

Indicates a potentially hazardous situation which, if not avoided, could result in death or serious injury.

#### CAUTION

Indicates a potentially hazardous situation which, if not avoided, may result in minor or moderate injury.

#### CAUTION

Indicates a potentially hazardous situation which, if not avoided, may result in equipment damage only.

### Safety instructions

Following are general caution and warning statements that apply to this equipment. Additional statements, related to specific tasks and procedures, are located throughout the manual.

#### DANGER

**Hazardous voltage. Contact with high voltage will cause death or severe personal injury. Follow all locally approved safety procedures when working around high- and low-voltage lines and equipment.**

#### WARNING

**Before installing, operating, maintaining, or testing this equipment, carefully read and understand the contents of this manual. Improper operation, handling or maintenance can result in death, severe personal injury, and equipment damage.**

#### WARNING

**This equipment is not intended to protect human life. Follow all locally approved procedures and safety practices when installing or operating this equipment. Failure to comply may result in death, severe personal injury and equipment damage.**

#### WARNING

**Power distribution and transmission equipment must be properly selected for the intended application. It must be installed and serviced by competent personnel who have been trained and understand proper safety procedures. These instructions are written for such personnel and are not a substitute for adequate training and experience in safety procedures. Failure to properly select, install, or maintain power distribution and transmission equipment can result in death, severe personal injury, and equipment damage.**

# S.T.A.R. Type ER faulted circuit indicator installation instructions

## Product information

### Introduction

The Eaton Cooper Power series S.T.A.R. Electrostatic Reset (ER) Faulted Circuit Indicators are used primarily on overhead conductors and indicate the passage of fault current by showing a “fault” flag in the Fisheye display window. When the fault is cleared from the system and the line is re-energized, the fault indicator will automatically reset. A minimum of 6.9 kV line-to-ground is needed in order to reset the fault indicator.

The Eaton Cooper Power series S.T.A.R. Faulted Circuit Indicator (FCI) is weatherproof, submersible and meets or exceeds IEEE Std 495™-1986 standard IEEE “Guide for Testing Faulted Circuit Indicators”. The Fisheye target display will not change status due to mechanical shock or vibration.

The S.T.A.R. ER Faulted Circuit Indicator clamps easily to the overhead conductor by using a standard clamp (shotgun) stick. It is primarily for use on uninsulated, unshielded cable, but may also be used on insulated unshielded cable such as tree wire. The fault indicator clamping mechanism will allow the indicator to be used on cable sizes from 0.25” (6.4 mm) up to 2.0” (51 mm) in diameter.

The FCI is available with either a high (HI) or low (LO) trip level. A low trip level will activate at approximately 400 A on a 1.2” diameter cable and the high trip operates at approximately 900 A on the same cable size. The trip rating will vary slightly for other cable dimensions. Refer to Figure 2 for trip levels on other cable diameters.

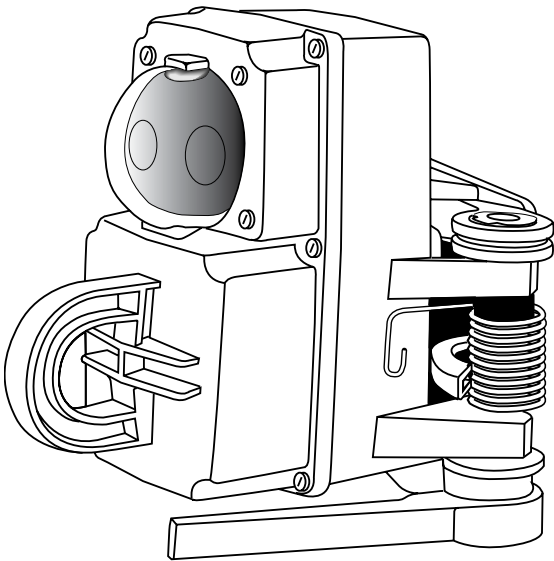

Figure 1. S.T.A.R. Type ER faulted circuit indicator

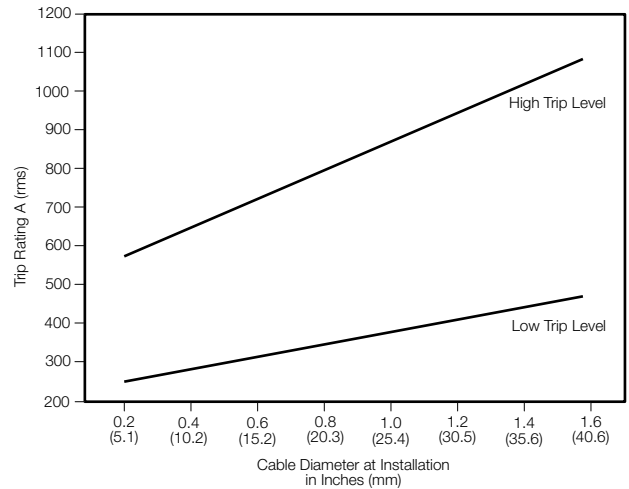

Figure 2. S.T.A.R. Type ER faulted circuit indicator cable diameter vs. Trip value curves

### Read this manual first

Read and understand the contents of this manual and follow all locally approved procedures and safety practices before installing or operating this equipment.

### Additional information

These instructions cannot cover all details or variations in the equipment, procedures, or process described nor provide directions for meeting every possible contingency during installation, operation, or maintenance. For additional information, contact your representative.

### Acceptance and initial inspection

Each faulted circuit indicator is in good condition when accepted by the carrier for shipment. Upon receipt, inspect the shipping container for signs of damage. Unpack the faulted circuit indicator and inspect it thoroughly for damage incurred during shipment. If damage is discovered, file a claim with the carrier immediately.

### Handling and storage

Be careful during handling and storage of the faulted circuit indicator to minimize the possibility of damage. If the faulted circuit indicator is to be stored for any length of time prior to installation, provide a clean, dry storage area.

### Standards

ISO 9001 Certified Quality Management System

## Installation procedure

1. **Arm the FCI clamp mechanism** by grasping each clamping arm (Figure 3), pulling them apart until the trigger arm latches into place. Stops have been built into the clamping arms such that they will only open to the point where the trigger arm will latch (Figure 4).
2. **Attach the FCI to a clamp (shotgun) stick** using the pulling eye on the front of the faulted circuit indicator. At 6.9 kV, the S.T.A.R. ER Type Fault Circuit Indicator should be installed no more than five feet from a ground plane.
3. **Push the FCI clamping mechanism** against the conductor until the trigger mechanism releases from the latched position. Remove the clamp stick.

For cable diameters from 0.25" (6.4 mm) to 1.0" (25 mm), the clamp arm pads are required to properly clamp onto the conductor. For cable diameters from 1.0" up to 2.0" (51 mm), the clamp arm pads are not needed and should be removed.

The S.T.A.R. ER Type Faulted Circuit Indicator is shipped to the customer in the tripped position. When properly installed, the FCI will reset in approximately 8 minutes on a 6.9 kV line-to-ground system. The FCI reset time may vary depending on the system voltage and distance to the nearest ground plane. Refer to Table 1 for nominal reset times.

**Table 1. Ground plane vs. Reset time**

Voltage (kV) line-to-ground	Reset time (minutes)
	FCI distance to ground plane
	<b>36 Inches</b>
6.9-8	8
8-26	6
>26	<4

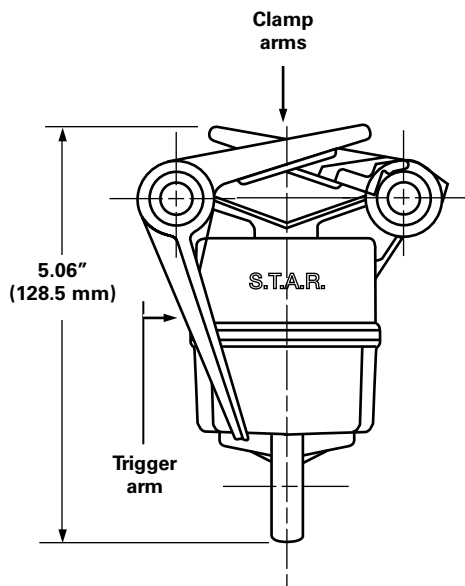

**Figure 3. Type ER faulted circuit indicator with clamp in unarmed position**

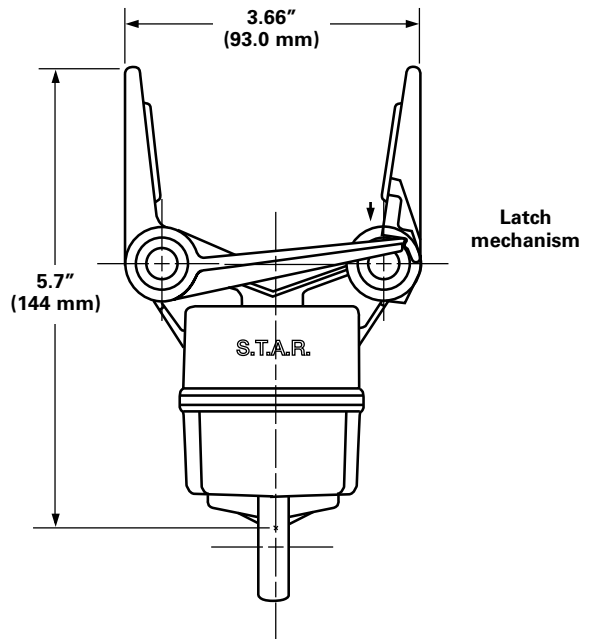

**Figure 4. Type ER faulted circuit indicator with clamp in armed position**

### **WARNING**

Care should be used when installing the FCI on a de-energized system without the use of a shotgun stick. When the clamping mechanism closes, the trigger arm swiftly swings toward the pulling eye and injury could occur if fingers or hands are in the trigger arm's path.

### Removing the FCI

1. Insert the hook end from the shotgun stick into the pulling eye of the FCI and lock the shotgun stick tight against the FCI body.
2. Pull straight back on the hotstick. For quicker/simpler removal of the FCI, it can be removed with hot-line gloves.
3. If the clamp pads are to be used with the FCI upon re-installation, ensure that the pads are properly attached to the clamp arms.

## S.T.A.R. Type ER faulted circuit indicator installation instructions

### Operation instructions

The S.T.A.R. Type ER Fault Indicator utilizes the FISHEYE display and will rotate the ball from 'black' to 'orange' to indicate sensing a fault. The ball will remain in the 'orange' position indefinitely until the system is restored and a minimum of 6.9 kV is present. If the FCI is equipped with the optional LED indicator, both the FISHEYE as well as the LED will sense the restoration of voltage and will reset the FISHEYE back to the 'black' position and turn off the LED. Note: the LED equipped FCI will blink for a maximum 4 hours per fault event.

The FCI will sense the loss of 60 Hz pulses and will disable the tripping circuitry following the loss of power. This is done to prevent false tripping on Reclosure operations.

The LED version is equipped with a non-replaceable battery, which is used only to provide power for the LED indicator. If the battery fails the FCI will still function and the FISHEYE display will continue to operate.



**Eaton**  
1000 Eaton Boulevard  
Cleveland, OH 44122  
United States  
Eaton.com

**Eaton's Power Systems Division**  
2300 Badger Drive  
Waukesha, WI 53188  
United States  
Eaton.com/cooperpowerseries

© 2017 Eaton  
All Rights Reserved  
Printed in USA  
Publication No. MN320006EN Rev 0  
Supersedes S320601 Rev 2  
March 2017

Eaton is a registered trademark.

All trademarks are property  
of their respective owners.

For Eaton's Cooper Power series product  
information  
call 1-877-277-4636 or visit:  
[www.eaton.com/cooperpowerseries](http://www.eaton.com/cooperpowerseries).