

S.T.A.R.™ Type DR faulted circuit indicator installation instructions

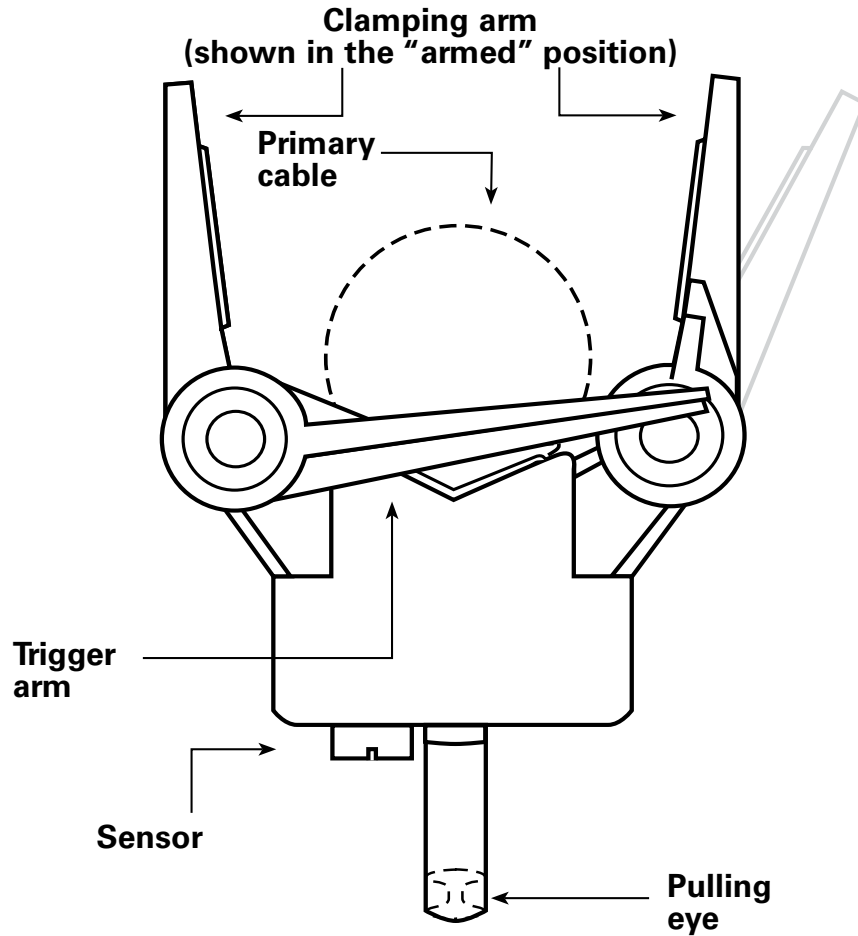

DISCLAIMER OF WARRANTIES AND LIMITATION OF LIABILITY

The information, recommendations, descriptions and safety notations in this document are based on Eaton Corporation's ("Eaton") experience and judgment and may not cover all contingencies. If further information is required, an Eaton sales office should be consulted. Sale of the product shown in this literature is subject to the terms and conditions outlined in appropriate Eaton selling policies or other contractual agreement between Eaton and the purchaser.

THERE ARE NO UNDERSTANDINGS, AGREEMENTS, WARRANTIES, EXPRESSED OR IMPLIED, INCLUDING WARRANTIES OF FITNESS FOR A PARTICULAR PURPOSE OR MERCHANTABILITY, OTHER THAN THOSE SPECIFICALLY SET OUT IN ANY EXISTING CONTRACT BETWEEN THE PARTIES. ANY SUCH CONTRACT STATES THE ENTIRE OBLIGATION OF EATON. THE CONTENTS OF THIS DOCUMENT SHALL NOT BECOME PART OF OR MODIFY ANY CONTRACT BETWEEN THE PARTIES.

In no event will Eaton be responsible to the purchaser or user in contract, in tort (including negligence), strict liability or otherwise for any special, indirect, incidental or consequential damage or loss whatsoever, including but not limited to damage or loss of use of equipment, plant or power system, cost of capital, loss of power, additional expenses in the use of existing power facilities, or claims against the purchaser or user by its customers resulting from the use of the information, recommendations and descriptions contained herein. The information contained in this manual is subject to change without notice.

Contents

DISCLAIMER OF WARRANTIES AND LIMITATION OF LIABILITY I

SAFETY FOR LIFE III

SAFETY INFORMATION III
 Safety instructions iii

PRODUCT INFORMATION 1
 Introduction 1
 Read this manual first 1
 Additional information 1
 Acceptance and initial inspection 1
 Handling and storage 1
 Standards 1

INSTALLATION PROCEDURE 2
 Primary cable preparation 2
 Installation of the FCI 3



Safety for life



Eaton's Cooper Power series products meet or exceed all applicable industry standards relating to product safety. We actively promote safe practices in the use and maintenance of our products through our service literature, instructional training programs, and the continuous efforts of all Eaton employees involved in product design, manufacture, marketing and service.

We strongly urge that you always follow all locally approved safety procedures and safety instructions when working around high-voltage lines and equipment and support our "Safety For Life" mission.

Safety information

The instructions in this manual are not intended as a substitute for proper training or adequate experience in the safe operation of the equipment described. Only competent technicians, who are familiar with this equipment should install, operate and service it.

A competent technician has these qualifications:

- Is thoroughly familiar with these instructions.
- Is trained in industry-accepted high- and low-voltage safe operating practices and procedures.
- Is trained and authorized to energize, de-energize, clear, and ground power distribution equipment.
- Is trained in the care and use of protective equipment such as flash clothing, safety glasses, face shield, hard hat, rubber gloves, hotstick, etc.

Following is important safety information. For safe installation and operation of this equipment, be sure to read and understand all cautions and warnings.

Hazard Statement Definitions

This manual may contain four types of hazard statements:

DANGER

Indicates an imminently hazardous situation which, if not avoided, will result in death or serious injury.

WARNING

Indicates a potentially hazardous situation which, if not avoided, could result in death or serious injury.

CAUTION

Indicates a potentially hazardous situation which, if not avoided, may result in minor or moderate injury.

CAUTION

Indicates a potentially hazardous situation which, if not avoided, may result in equipment damage only.

Safety instructions

Following are general caution and warning statements that apply to this equipment. Additional statements, related to specific tasks and procedures, are located throughout the manual.

DANGER

Hazardous voltage. Contact with high voltage will cause death or severe personal injury. Follow all locally approved safety procedures when working around high- and low- voltage lines and equipment.

WARNING

Before installing, operating, maintaining, or testing this equipment, carefully read and understand the contents of this manual. Improper operation, handling or maintenance can result in death, severe personal injury, and equipment damage.

WARNING

This equipment is not intended to protect human life. Follow all locally approved procedures and safety practices when installing or operating this equipment. Failure to comply may result in death, severe personal injury and equipment damage.

WARNING

Power distribution and transmission equipment must be properly selected for the intended application. It must be installed and serviced by competent personnel who have been trained and understand proper safety procedures. These instructions are written for such personnel and are not a substitute for adequate training and experience in safety procedures. Failure to properly select, install, or maintain power distribution and transmission equipment can result in death, severe personal injury, and equipment damage.

Product information

Introduction

The Eaton Cooper Power series S.T.A.R. Type DR (Delayed Reset) Faulted Circuit Indicator (FCI) is cable mounted and indicates the passage of fault current by flashing the LED target display. After a preset amount of time, the FCI will automatically reset to the normal position. The FCI is weatherproof, submersible and meets or exceeds **IEEE 495-1986™** "Guide for Testing Faulted Circuit Indicators." The unit can also be reset by the use of a manual reset tool (SMRT).

The DR Faulted Circuit Indicator consists of a clamp-on sensing unit with a patented clamping mechanism that allows one unit to be used on cable sizes from 0.7" to 2.0". The FCI is available with either a low (LO) or high (HI) trip rating that is factory preset. The LO trip rating will trip at approximately 400 A on a 1.0" diameter cable, while the HI trip will trip at approximately 800 A on the same size cable. The trip rating will vary slightly depending on cable dimensions. Refer to figure 2 for trip levels on other cable diameters.

The DR type FCI also has a means to verify battery operation. Simply use the SMRT reset tool to activate the reset mechanism and the unit will "blink back" the number of reset hours that the unit is set for.

Read this manual first

Read and understand the contents of this manual and follow all locally approved procedures and safety practices before installing or operating this equipment.

Additional information

These instructions cannot cover all details or variations in the equipment, procedures, or process described nor provide directions for meeting every possible contingency during installation, operation, or maintenance. For additional information, contact your Eaton representative.

Acceptance and initial inspection

Each faulted circuit indicator is in good condition when accepted by the carrier for shipment. Upon receipt, inspect the shipping container for signs of damage. Unpack the faulted circuit indicator and inspect it thoroughly for damage incurred during shipment. If damage is discovered, file a claim with the carrier immediately.

Handling and storage

Be careful during handling and storage of the faulted circuit indicator to minimize the possibility of damage. If the faulted circuit indicator is to be stored for any length of time prior to installation, provide a clean, dry storage area.

Standards

ISO 9001 Certified Quality Management System.

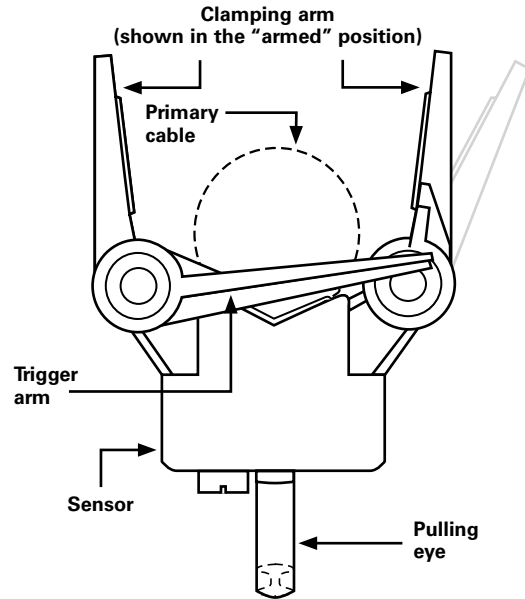

Figure 1. S.T.A.R. DR faulted circuit indicator

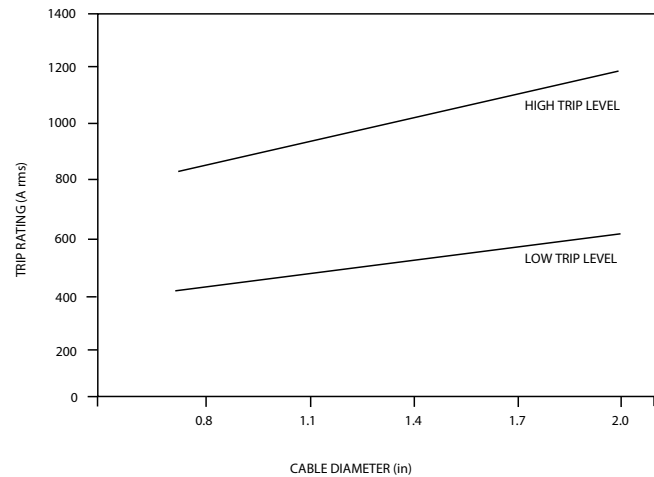

Figure 2. S.T.A.R Type DR faulted circuit indicator cable diameter vs . Trip value curves

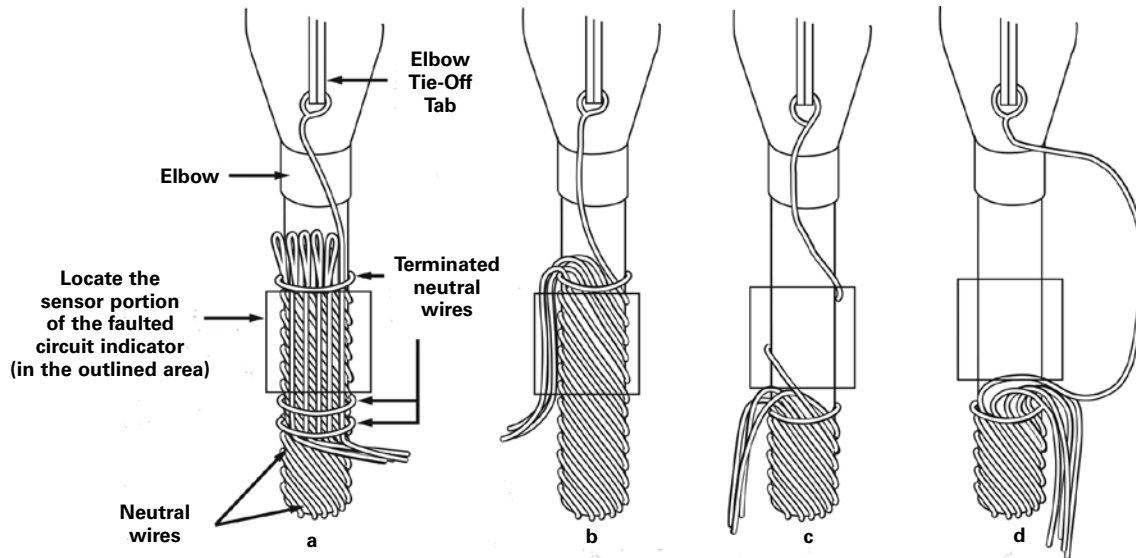

Figure 3. Recommended methods of concentric neutral primary cable preparation

Installation procedure

Primary cable preparation

Proper primary cable preparation is necessary for the Delayed Reset faulted circuit indicator to work reliably on underground distribution circuits. The FCI can be used on tape shield or drain wire cable. If the cable does not provide a return path for the fault current, the FCI can be installed directly over the cable. If the cable shield provides a return path for the fault current, the FCI will not reliably detect a fault and will require the use of a tape shield or drain wire adapter. When used, the adapter must be installed approximately 3.5" below the elbow to allow space for mounting the FCI on the cable.

One of the following four methods is preferred for installation on concentric neutral primary cable.

Method 1 (refer to figure 3-a)

1. **Attach one or two strands of the concentric neutral wrapped around the cable to the tie-off tab on the elbow.**
2. **Terminate all of the remaining neutral wires approximately 6" below the elbow.**
3. **Pull the neutral wires straight up and terminate them again just below the elbow.** The wires should then be bent back down the cable which is commonly referred to as "double back".
4. **Terminate the ground wires approximately 6" below the elbow.**

Note: The FCI is installed over the "double back" neutral wires to cancel the effect of current in the neutral. The exact trip value is dependent on the overall diameter of the "double back" neutral wires.

Method 2 (refer to figure 3-b)

1. **Attach one or two strands of the concentric neutral wrapped around the cable to the tie-off tab on the elbow.**
2. **Terminate all of the remaining neutral wires just below the elbow.** The balance of the neutral wires should be gathered together and "double backed" down the cable and grounded.

Note: The FCI is installed over the "double back" neutral wires to cancel the effect of current in the neutral. The exact trip value is dependent on the overall diameter of the "double back" neutral wires.

Method 3 (refer to figure 3-c)

1. **Attach one or two strands of the concentric neutral wrapped around the cable to the tie-off tab on the elbow.**
2. **Terminate and ground all of the remaining neutral wires approximately 6" below the elbow.**

Method 4 (refer to figure 3-d)

1. **Arch one or two strands of the concentric neutral wrapped around the cable and attach it to the tie-off tab on the elbow.** The arc should be large enough to go around the outside FCI when the FCI is installed.

Some installations of improper preparation of the primary cable will result in an inoperable FCI (see Figure 4a and 4b). The magnetic field, due to current in the center conductor, will be cancelled by the current in the concentric neutral wires. **DO NOT PREPARE THE PRIMARY CABLE IN ACCORDANCE WITH THE METHODS SHOWN IN FIGURE 4!**

S.T.A.R.™ Type DR faulted circuit indicator installation instructions

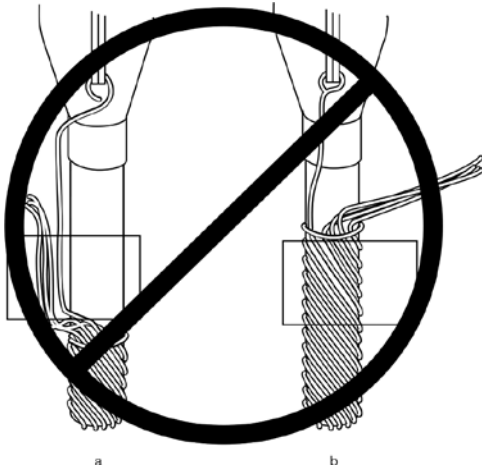

Figure 4. Incorrect methods of concentric neutral primary cable preparation

Installation of the FCI

1. **Arm the FCI clamping mechanism by carefully grasping both clamping arms, pulling them apart until the trigger mechanism drops into place.** Stops have been built into the clamping arms such that they can only be opened to the point where the trigger will latch.
2. **Attach the sensor to a shotgun clamp stick using the FCI pulling eye.**
- 3a. **Push the sensor onto the cable below the elbow at a location shown in Figure 2 while holding the shotgun stick horizontal.** The triggering mechanism will release the clamping arms and securely attach the device to the cable.
- 3b. **For overhead applications, simply push the FCI onto the desired cable.** The triggering mechanism will release the clamping arms and securely attach the device to the cable.
4. **Remove the shotgun stick.**
5. **If the FCI target begins to flash due to the shock of the clamping mechanism closing, reset the FCI with the manual reset tool (SMRT) or allow the unit to reset after the preset reset time interval.**



Figure 5. Reset and test locations for the DR type FCI

Resetting the FCI

1. **Install the reset tool, catalog number SMRT, on a shotgun clamp stick.**
2. **Touch the magnetic end of the reset tool to the face of the fault indicator in the upper left corner at the location of the "R"** (see Figure 5).
3. **Remove the reset tool from the face of the fault indicator.** The unit should "flash back" the number of reset hours that the FCI is set for. This procedure also provides positive indication of battery operation.

Testing the FCI

1. **Install the reset tool, catalog number SMRT, on a shotgun clamp stick.**
2. **Touch the magnetic end of the reset tool to the face of the fault indicator in the lower right corner at the location of the "T"** (see Figure 5).
3. **Remove the reset tool from the face of the fault indicator.** The unit should "flash back" continuously until the unit is manually reset or until it times out.



Eaton
1000 Eaton Boulevard
Cleveland, OH 44122
United States
Eaton.com

Eaton's Power Systems Division
2300 Badger Drive
Waukesha, WI 53188
United States
Eaton.com/cooperpowerseries

© 2017 Eaton
All Rights Reserved
Printed in USA
Publication No. MN320007EN
March 2017
#5000050828 Rev. 2

Eaton is a registered trademark.

All trademarks are property
of their respective owners.

For Eaton's Cooper Power series product
information
call 1-877-277-4636 or visit:
www.eaton.com/cooperpowerseries.