

S.T.A.R.™ Hot line voltage indicator installation instructions

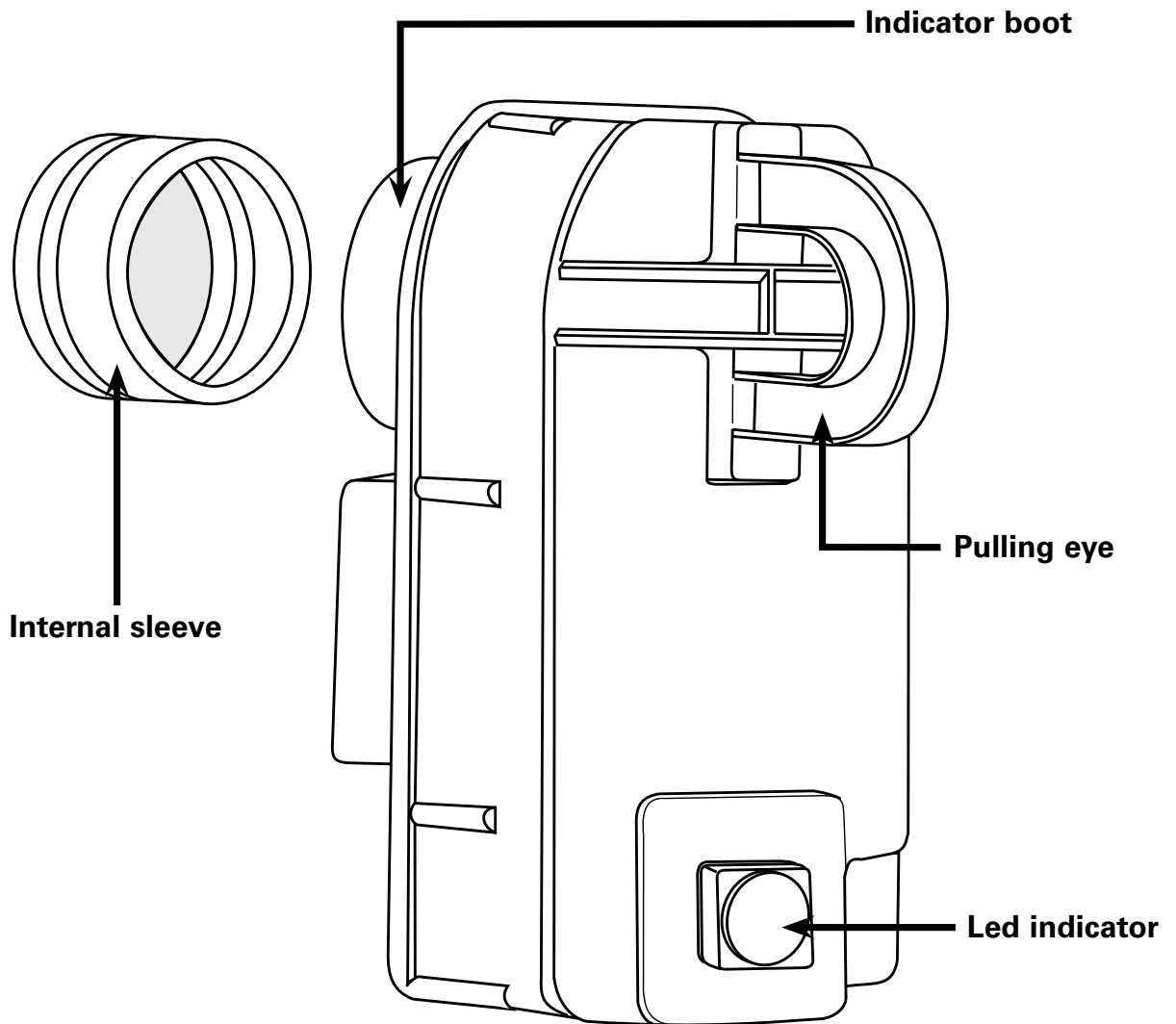

DISCLAIMER OF WARRANTIES AND LIMITATION OF LIABILITY

The information, recommendations, descriptions and safety notations in this document are based on Eaton Corporation's ("Eaton") experience and judgment and may not cover all contingencies. If further information is required, an Eaton sales office should be consulted. Sale of the product shown in this literature is subject to the terms and conditions outlined in appropriate Eaton selling policies or other contractual agreement between Eaton and the purchaser.

THERE ARE NO UNDERSTANDINGS, AGREEMENTS, WARRANTIES, EXPRESSED OR IMPLIED, INCLUDING WARRANTIES OF FITNESS FOR A PARTICULAR PURPOSE OR MERCHANTABILITY, OTHER THAN THOSE SPECIFICALLY SET OUT IN ANY EXISTING CONTRACT BETWEEN THE PARTIES. ANY SUCH CONTRACT STATES THE ENTIRE OBLIGATION OF EATON. THE CONTENTS OF THIS DOCUMENT SHALL NOT BECOME PART OF OR MODIFY ANY CONTRACT BETWEEN THE PARTIES.

In no event will Eaton be responsible to the purchaser or user in contract, in tort (including negligence), strict liability or otherwise for any special, indirect, incidental or consequential damage or loss whatsoever, including but not limited to damage or loss of use of equipment, plant or power system, cost of capital, loss of power, additional expenses in the use of existing power facilities, or claims against the purchaser or user by its customers resulting from the use of the information, recommendations and descriptions contained herein. The information contained in this manual is subject to change without notice.

Contents

DISCLAIMER OF WARRANTIES AND LIMITATION OF LIABILITY I

SAFETY FOR LIFE III

SAFETY INFORMATION III

 Safety instructions iii

PRODUCT INFORMATION 1

INSTALLATION PROCEDURES 1

 For RTE 15, 25, and 35 kV Loadbreak Elbows and
 GE-Chardon 15 and 35 kV Elbows 1

 For all Cooper Power Systems 200 a, 250 a and 400 a Deadbreak Elbows, Elastimold 15, 25 and
 35 kV (PCE) Elbows and New Design Blackburn 15 kV Elbows 1

 For Old Design* 15 and 25 kV Blackburn Elbows Elastimold 15, 25 and 35 kV (not PCE)
 Elbows Joslyn 15 kV Elbows and GE-Chardon 25 kV Elbows 2



Safety for life



Eaton's Cooper Power series products meet or exceed all applicable industry standards relating to product safety. We actively promote safe practices in the use and maintenance of our products through our service literature, instructional training programs, and the continuous efforts of all Eaton employees involved in product design, manufacture, marketing and service.

We strongly urge that you always follow all locally approved safety procedures and safety instructions when working around high-voltage lines and equipment and support our "Safety For Life" mission.

Safety information

The instructions in this manual are not intended as a substitute for proper training or adequate experience in the safe operation of the equipment described. Only competent technicians, who are familiar with this equipment should install, operate and service it.

A competent technician has these qualifications:

- Is thoroughly familiar with these instructions.
- Is trained in industry-accepted high- and low-voltage safe operating practices and procedures.
- Is trained and authorized to energize, de-energize, clear, and ground power distribution equipment.
- Is trained in the care and use of protective equipment such as flash clothing, safety glasses, face shield, hard hat, rubber gloves, hotstick, etc.

Following is important safety information. For safe installation and operation of this equipment, be sure to read and understand all cautions and warnings.

Hazard Statement Definitions

This manual may contain four types of hazard statements:

DANGER

Indicates an imminently hazardous situation which, if not avoided, will result in death or serious injury.

WARNING

Indicates a potentially hazardous situation which, if not avoided, could result in death or serious injury.

CAUTION

Indicates a potentially hazardous situation which, if not avoided, may result in minor or moderate injury.

CAUTION

Indicates a potentially hazardous situation which, if not avoided, may result in equipment damage only.

Safety instructions

Following are general caution and warning statements that apply to this equipment. Additional statements, related to specific tasks and procedures, are located throughout the manual.

DANGER

Hazardous voltage. Contact with high voltage will cause death or severe personal injury. Follow all locally approved safety procedures when working around high- and low-voltage lines and equipment.

WARNING

Before installing, operating, maintaining, or testing this equipment, carefully read and understand the contents of this manual. Improper operation, handling or maintenance can result in death, severe personal injury, and equipment damage.

WARNING

This equipment is not intended to protect human life. Follow all locally approved procedures and safety practices when installing or operating this equipment. Failure to comply may result in death, severe personal injury and equipment damage.

WARNING

Power distribution and transmission equipment must be properly selected for the intended application. It must be installed and serviced by competent personnel who have been trained and understand proper safety procedures. These instructions are written for such personnel and are not a substitute for adequate training and experience in safety procedures. Failure to properly select, install, or maintain power distribution and transmission equipment can result in death, severe personal injury, and equipment damage.

CAUTION

The Eaton Cooper Power series S.T.A.R.™ Type HL Voltage Indicator is designed to be operated in accordance with normal safe operating procedures. These instructions are not intended to supersede or replace existing safety and operating procedures. Read all the instructions before installing the voltage indicator.

Voltage indicators should be installed and serviced only by personnel familiar with good safety practice and the handling of high-voltage electrical equipment. Improper operation, handling, or maintenance can result in death, severe personal injury, and equipment damage.

Product information

The Eaton Cooper Power series S.T.A.R.™ Hot Line (HL) Voltage Indicators are used on both 200 A separable connectors and 600 A terminators with voltage test points. They are easily installed with a shotgun stick using the pulling eye. The indicator displays the presence of voltage by showing a flashing LED in the window of the display. When the system is de-energized, the indicator LED will not flash.

The voltage indicator is weatherproof, submersible, and meets or exceeds applicable portions of **ANSI®/IEEE 495-1986™** Testing Guide.

WARNING

Do not use this device as the only indication that the circuit is energized or de-energized. A dirty, wet or otherwise faulty test point or indicator could cause a false reading indicating a dead circuit. Always use an approved means to be certain the circuit is de-energized before operating associated equipment designed for deadbreak operation.

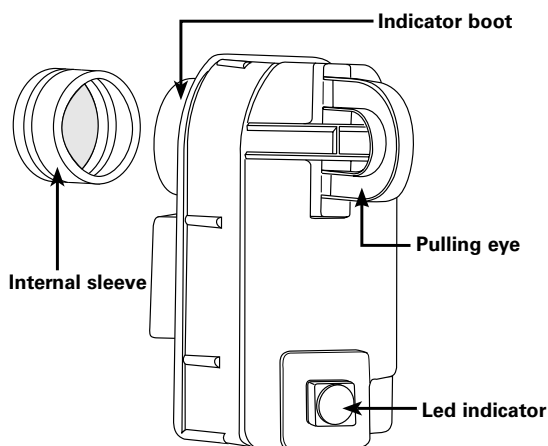

Figure 1. S.T.A.R. Hot line voltage indicator with internal sleeve

These instructions do not claim to cover all details or variations in the equipment, procedure, or process described, nor to provide directions for meeting every contingency during installation, operation, or maintenance. When additional information is desired to satisfy a problem not covered sufficiently for the user's purpose, contact your Eaton representative.

Note: At least 2.4 kV line-to-ground must be present to operate the device.

Installation procedures

The Hot Line voltage indicator can be installed on most manufacturers' elbows. Instructions are included herein for RTE, Elastimold, Blackburn, Joslyn and GE-Chardon elbows. Where an adapter is required, a kit must be ordered separately.

For RTE 15, 25, and 35 kV loadbreak elbows and GE-Chardon 15 and 35 kV elbows

1. **The voltage indicator can be installed on live elbows.** As an alternative, de-energize the circuit and elbow terminator and ground the terminator according to approved procedures.
2. **Remove the cap** from the elbow test point using a shotgun stick.
3. **Be sure the test point area is clean and dry.**
4. **Discard the internal sleeve.**
5. **Lightly lubricate the inside of the indicator boot** using a silicone lubricant.
6. **Attach the pulling eye** of the indicator to the shotgun stick.
7. **Using steady pressure**, push the boot over the test point while rotating the boot.
8. **Align the pulling eye on the indicator with the elbow pulling eye.**
9. **Re-energize the circuit if necessary.** The LED will pulse indicating the circuit is energized.

For all Eaton Cooper Power series 200 A, 250 A and 400 A deadbreak elbows, Elastimold 15, 25 and 35 kV (PCE) elbows and new design* Blackburn 15 kV elbows

1. **The voltage indicator can be installed on live Elastimold (PCE) or new design Blackburn elbows.** As an alternative, de-energize the circuit and elbow terminator and ground the terminator according to approved procedures.
2. **Remove the cap** from the elbow test point using a shotgun stick.
3. **Be sure the test point area is clean and dry.**
4. **Insert the internal sleeve** into the indicator boot.
5. **Lightly lubricate the inside of the internal sleeve** using a silicone lubricant.
6. **Attach the pulling eye** of the indicator to the shotgun stick.

7. **Using steady pressure, push the boot** over the test point while rotating the boot.
8. **Align the pulling eye on the indicator with the elbow pulling eye.**
9. **Re-energize the circuit if necessary.** The LED will pulse indicating the circuit is energized.

For old design* 15 and 25 kV blackburn elbows, elastimold 15, 25 and 35 kV (not PCE) elbows, joslyn 15 kV elbows and ge-chardon 25 kv elbows

1. **A separate adapter (Catalog # STAK) is required for the old design 15 and 25 kV Blackburn, Elastimold 15, 25 and 35 kV (not PCE), Joslyn 15 kV and GE-Chardon 25 kV elbows.** It is not included with the voltage indicator and must be ordered separately. Because an adapter is needed, a slotted screwdriver and hex head driver mounted on a shotgun stick with tool holder is also required.

Table 1. Adapter screw and thread sizes**

Elbow manufacturer	Screw & thread size	
15 and 25 kV Blackburn – Old Design	3/8 in.	24
15 kV Joslyn, Elastimold 15, 25 and 35 kV (Not PCE)	5/16 in.	24
25 kV GE-Chardon	1/4 in.	20

** Consult your Eaton representative for other available screw sizes.

2. **De-energize the circuit** and elbow terminator and ground the terminator according to approved procedures.
3. **Remove the cap from the elbow test point.**
4. **Remove and discard the screw and steel washer** from the center of the test point. From the referenced adapter kit, select the proper adapter screw and thread size from Table 1.
5. **Be sure the test point is clean and dry.**
6. **Using the 7/64 inch hex wrench** provided, screw the adapter and plastic washer into the test point using the shotgun stick with tool holder.
7. **Discard the internal sleeve.**
8. **Lightly lubricate the inside of the indicator** boot using a silicone lubricant.
9. **Attach the pulling eye** of the indicator to the shotgun stick.
10. **Using steady pressure,** push the boot over the test point while rotating the boot.
11. **Align the pulling eye on the indicator** with the elbow pulling eye.
12. **Re-energize the circuit if necessary.** The LED will pulse indicating the circuit is energized.

* Blackburn completed an elbow design change around July 1992. Any Blackburn elbow sold and/or shipped prior to July 1992 could be of either the old or new design. After determining the design, follow the appropriate instructions for installing the indicator.

S.T.A.R.™ Hot line voltage indicator installation instructions

This page intentionally left blank.



Eaton
1000 Eaton Boulevard
Cleveland, OH 44122
United States
Eaton.com

Eaton's Power Systems Division
2300 Badger Drive
Waukesha, WI 53188
United States
Eaton.com/cooperpowerseries

© 2017 Eaton
All Rights Reserved
Printed in USA
Publication No. MN320011EN
March 2017
#5000038078 Rev. 04

Eaton is a registered trademark.

All trademarks are property
of their respective owners.

For Eaton's Cooper Power series product
information
call 1-877-277-4636 or visit:
www.eaton.com/cooperpowerseries.