

Single-Phase MagneX™ Interrupter Retrofit Float Kit, MXFLOATKIT, Installation Instructions

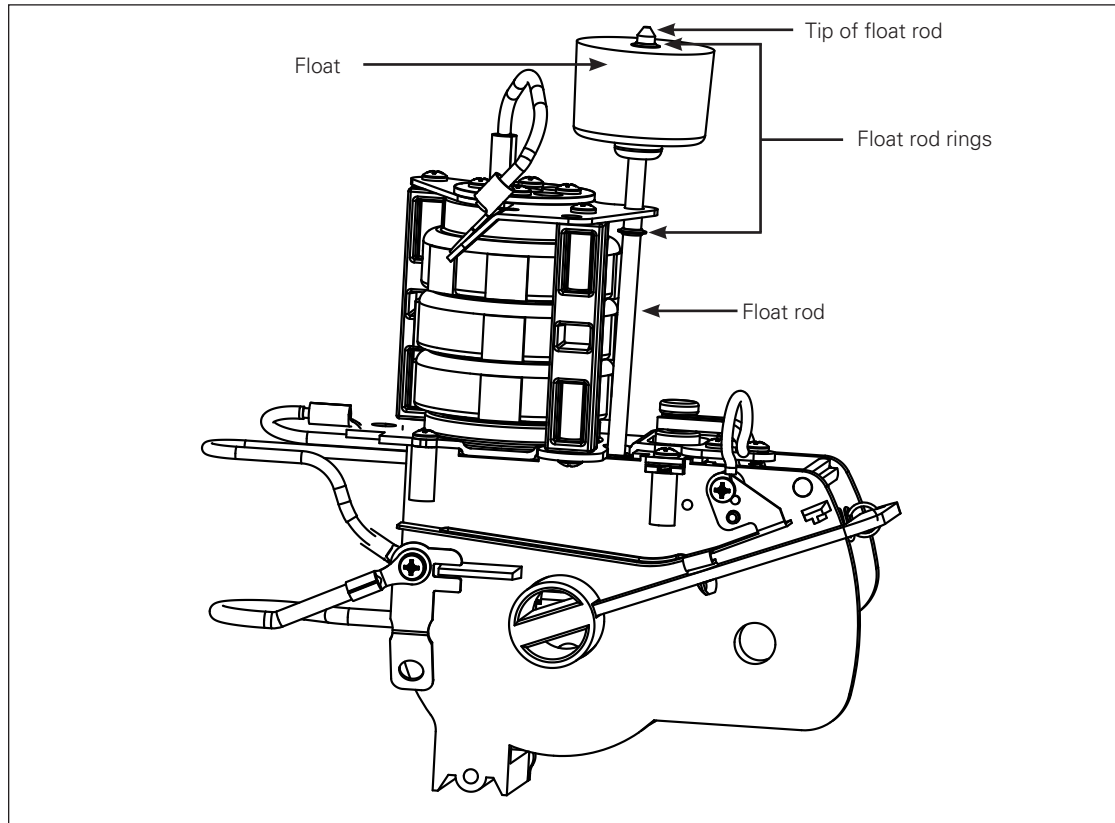

DISCLAIMER OF WARRANTIES AND LIMITATION OF LIABILITY

The information, recommendations, descriptions and safety notations in this document are based on Eaton Corporation's ("Eaton") experience and judgment and may not cover all contingencies. If further information is required, an Eaton sales office should be consulted. Sale of the product shown in this literature is subject to the terms and conditions outlined in appropriate Eaton selling policies or other contractual agreement between Eaton and the purchaser.

THERE ARE NO UNDERSTANDINGS, AGREEMENTS, WARRANTIES, EXPRESSED OR IMPLIED, INCLUDING WARRANTIES OF FITNESS FOR A PARTICULAR PURPOSE OR MERCHANTABILITY, OTHER THAN THOSE SPECIFICALLY SET OUT IN ANY EXISTING CONTRACT BETWEEN THE PARTIES. ANY SUCH CONTRACT STATES THE ENTIRE OBLIGATION OF EATON. THE CONTENTS OF THIS DOCUMENT SHALL NOT BECOME PART OF OR MODIFY ANY CONTRACT BETWEEN THE PARTIES.

In no event will Eaton be responsible to the purchaser or user in contract, in tort (including negligence), strict liability or otherwise for any special, indirect, incidental or consequential damage or loss whatsoever, including but not limited to damage or loss of use of equipment, plant or power system, cost of capital, loss of power, additional expenses in the use of existing power facilities, or claims against the purchaser or user by its customers resulting from the use of the information, recommendations and descriptions contained herein. The information contained in this manual is subject to change without notice.

Contents

DISCLAIMER OF WARRANTIES AND LIMITATION OF LIABILITY II

SAFETY FOR LIFEIV

SAFETY INFORMATIONIV
 Safety Instructions. iv

PRODUCT INFORMATION. 1
 Introduction1
 Acceptance and initial inspection1
 Handling and storage.2
 Standards2

INSTALLATION INSTRUCTIONS. 2



Safety for life



Eaton's Cooper Power series products meet or exceed all applicable industry standards relating to product safety. We actively promote safe practices in the use and maintenance of our products through our service literature, instructional training programs, and the continuous efforts of all Eaton employees involved in product design, manufacture, marketing and service.

We strongly urge that you always follow all locally approved safety procedures and safety instructions when working around high-voltage lines and equipment and support our "Safety For Life" mission.

Safety information

The instructions in this manual are not intended as a substitute for proper training or adequate experience in the safe operation of the equipment described. Only competent technicians, who are familiar with this equipment should install, operate and service it.

A competent technician has these qualifications:

- Is thoroughly familiar with these instructions.
- Is trained in industry-accepted high- and low-voltage safe operating practices and procedures.
- Is trained and authorized to energize, de-energize, clear, and ground power distribution equipment.
- Is trained in the care and use of protective equipment such as flash clothing, safety glasses, face shield, hard hat, rubber gloves, clampstick, hotstick, etc.

Following is important safety information. For safe installation and operation of this equipment, be sure to read and understand all cautions and warnings.

Hazard Statement Definitions

This manual may contain four types of hazard statements:

DANGER

Indicates a hazardous situation which, if not avoided, will result in death or serious injury.

WARNING

Indicates a hazardous situation which, if not avoided, could result in death or serious injury.

CAUTION

Indicates a hazardous situation which, if not avoided, may result in minor or moderate injury.

CAUTION

Indicates a hazardous situation which, if not avoided, may result in equipment damage only.

Safety instructions

Following are general caution and warning statements that apply to this equipment. Additional statements, related to specific tasks and procedures, are located throughout the manual.

DANGER

Hazardous voltage. Contact with high voltage will cause death or severe personal injury. Follow all locally approved safety procedures when working around high- and low-voltage lines and equipment.

WARNING

Before installing, operating, maintaining, or testing this equipment, carefully read and understand the contents of this manual. Improper operation, handling or maintenance can result in death, severe personal injury, and equipment damage.

WARNING

This equipment is not intended to protect human life. Follow all locally approved procedures and safety practices when installing or operating this equipment. Failure to comply may result in death, severe personal injury and equipment damage.

WARNING

Power distribution and transmission equipment must be properly selected for the intended application. It must be installed and serviced by competent personnel who have been trained and understand proper safety procedures. These instructions are written for such personnel and are not a substitute for adequate training and experience in safety procedures. Failure to properly select, install or maintain power distribution and transmission equipment can result in death, severe personal injury, and equipment damage.

Product information

Introduction

The MagneX™ interrupter retrofit float kit is designed to provide MagneX interrupter customers with the components required to replace the MagneX interrupter float.

Read this manual first

Read and understand the contents of this manual and follow all locally approved procedures and safety practices before installing or operating this equipment.

Additional information

These instructions cannot cover all details or variations in the equipment, procedures, or process described nor provide directions for meeting every possible contingency during installation, operation, or maintenance. For additional information, contact your representative.

WARNING

Eaton's Cooper Power series MagneX interrupter is designed to be operated in accordance with normal safe operating procedures. These instructions are not intended to supersede or replace existing safety and operating procedures.

Read all instructions before installing the MagneX interrupter float kit.

The interrupter should be installed and serviced only by personnel familiar with good safety practice and the handling of high-voltage electrical equipment. Failure to comply can result in death, severe personal injury and equipment damage.

Acceptance and initial inspection

Each MagneX interrupter float kit is in good condition when accepted by the carrier for shipment. Upon receipt, inspect the shipping container for signs of damage. Unpack the float kit and inspect it thoroughly for damage incurred during shipment. If damage is discovered, file a claim with the carrier immediately.

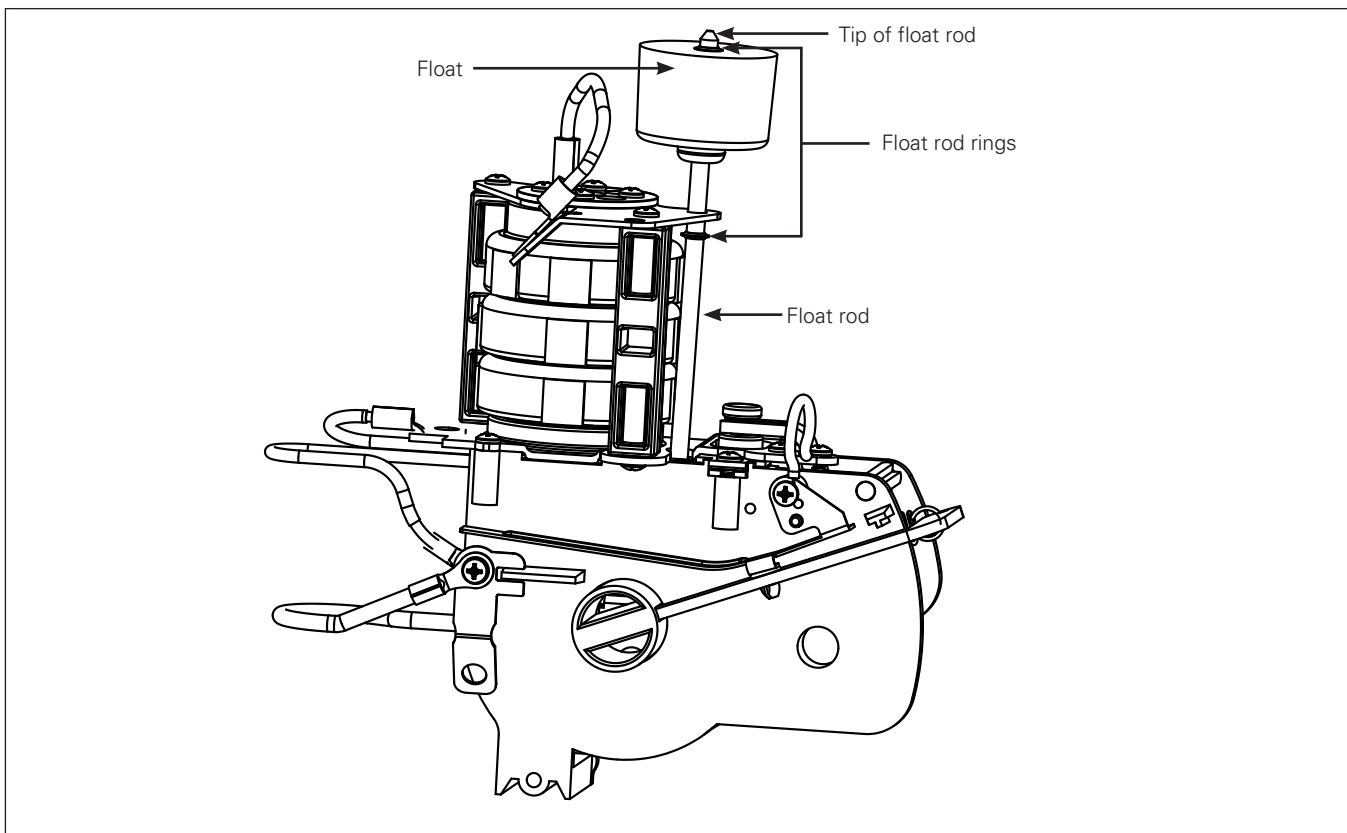

Figure 1. Side view of MagneX interrupter with factory installed float

Handling and storage

Be careful during handling and storage of the float kit to minimize the possibility of damage. If the float kit is to be stored for any length of time prior to installation, provide a clean, dry storage area.

Standards

ISO 9001 Certified Quality Management System

Installation instructions

Required equipment

4-inch fish net

Phillips-head screwdriver

Removal of float

1. Grasp tip of float rod.
2. Pull up an inch.
3. Position fish net under rod and tight up to float bracket.
4. Finish pulling float rod up.
5. Remove fish net and pulling tool with float from tank.
6. Make sure both rings are in net.
7. Put rings and float in re-sealable plastic bag.

Installation of new float

1. Use screwdriver to loosen screw, 5-half turns, DO NOT REMOVE SCREW.
2. Install retrofit float and slide retrofit float retainer under the loosened screw cap/head.
3. Install nylon push-pin in hole through retrofit plate and float bracket.
4. Tighten screw on float bracket.
5. Check tightness of retrofit float retainer by hand.
6. Push down on float to make sure float moves freely. Spin float while pushing down to check 360° rotation.

Inspection

1. Inspect re-sealable bag for two (2) rings and float with rod.

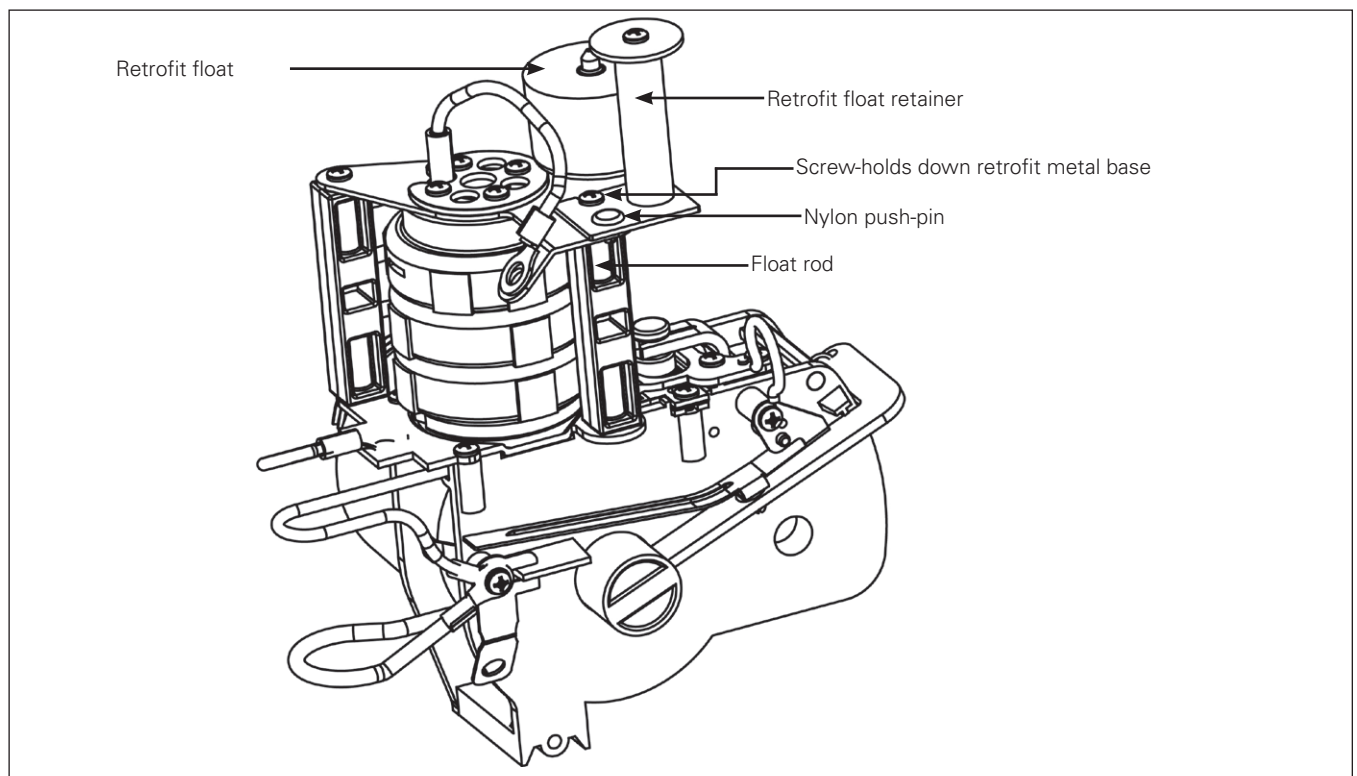

Figure 2. View of MagneX interrupter with retrofit float kit installed

This page is intentionally left blank.



Eaton
1000 Eaton Boulevard
Cleveland, OH 44122
United States
Eaton.com

Eaton's Power Systems Division
2300 Badger Drive
Waukesha, WI 53188
United States
Eaton.com/cooperpowerseries

EATON
Powering Business Worldwide

© 2016 Eaton
All Rights Reserved
Printed in USA
Publication No. MN132025EN / Rev. 0
November 2016

Eaton is a registered trademark.

All trademarks are property
of their respective owners.

For Eaton's Cooper Power series product
information
call 1-877-277-4636 or visit:
www.eaton.com/cooperpowerseries.