

# POSI-BREAK™ Metal Oxide Varistor Elbow (M.O.V.E.) Surge Arrester



## General

Eaton's Cooper Power™ series POSI-BREAK™ M.O.V.E. surge arrester combines metal (zinc) oxide varistor technology in a premolded rubber elbow to provide overvoltage system protection in an insulated, fully shielded, submersible, deadfront device.

The arrester housing interface conforms to IEEE Std 386™-2006 standard – Separable Insulated Connector Systems. The arrester housing is molded with high quality peroxide-cured EPDM rubber.

POSI-BREAK M.O.V.E. surge arresters are used on underground systems in pad-mounted transformer and entry cabinets, vaults, switching enclosures and other installations to provide shielded deadfront arrester protection. They are designed for use with 200 A loadbreak interfaces that conform to IEEE Std 386™-2006 and IEEE Std C62.11™-2005 standards to limit overvoltages to acceptable levels, protect equipment and extend cable life.

## Construction

The rubber body is constructed of high quality precision molded peroxide-cured EPDM insulation and semi-conductive materials. The design of the arrester housing utilizes state of the art manufacturing process that creates an insulated sleeve around the top of the copper probe. It also provides a layer of insulating rubber over the conductive internal insert of the elbow. This leaves the stress relieving feature around the current interchange intact and furnishes improved dielectrics and increased strike distance. Together these features provide superior switching performance and reliability.

The copper alloy probe and probe retainer are connected to the MOV block stack via welded flexible tin-plated copper leads. This ensures that the column cannot be damaged during installation and that a reliable current path to the MOV blocks is maintained. The disk column is composed of MOV disks bonded together with high-conductivity, silver-loaded epoxy to yield the most reliable electrical connection and eliminate air voids. The #4 AWG flexible copper ground lead, which reliably carries current to ground during voltage surges, is attached to the housing by a brass magneformed end cap. The brass end cap provides a tight, weatherproof seal.

**EATON**

*Powering Business Worldwide*

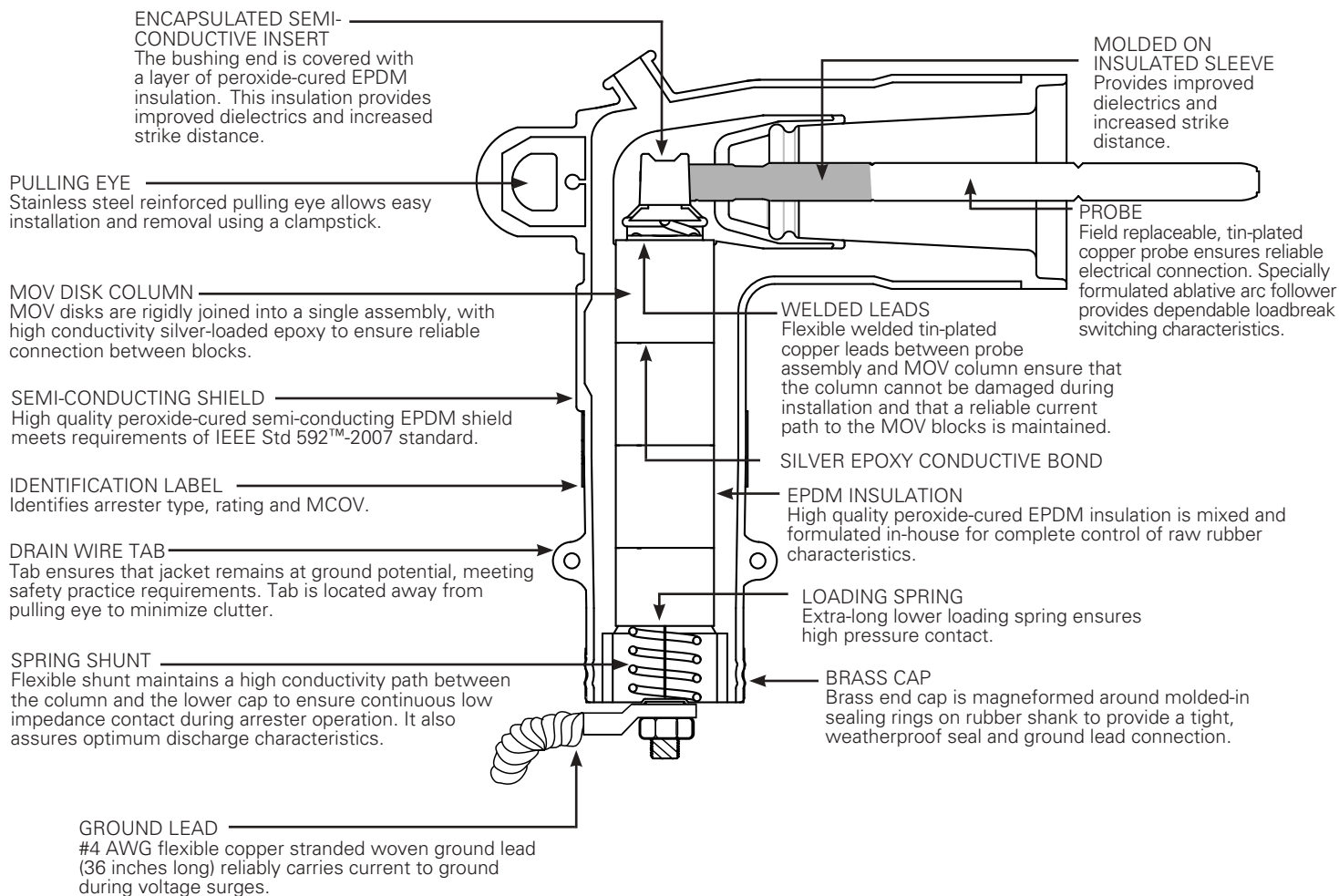

Figure 1. Cutaway illustration shows 25 kV Class POSI-BREAK M.O.V.E. surge arrester.

## Operation

Installing a POSI-BREAK M.O.V.E. surge arrester at the end of a radial system or at both ends of an open point on a loop system provides excellent overvoltage protection. The addition of a second POSI-BREAK M.O.V.E. surge arrester at the mid-point on a rotatable feedthru insert provides optimum protection. 600 A feeder circuits can be protected with elbow arresters installed on Eaton's Cooper Power series T-OP™ II and BT-TAP™ Separable Connector Systems.

## Standards

The POSI-BREAK M.O.V.E. surge arrester complies with the latest revisions of IEEE Std C62.11™-2005 standard "IEEE Standard for Metal Oxide Surge Arresters for AC Power Circuits" and IEEE Std 386™-2006 standard "Separable Insulated Connectors for Power Distribution Systems Above 600 Volts."

## Installation

All POSI-BREAK M.O.V.E. surge arresters can be installed or removed from energized bushings with a clampstick. No special tools are required. The arrester is placed on a 200 A interface by using a clampstick. Refer to *Service Information S235-55-1, 15, 25, and 35 kV Class Standard M.O.V.E. and POSI-BREAK M.O.V.E. Arrester Installation Instructions* for more details.

## Operating interface AC withstand test

Eaton's POSI-BREAK M.O.V.E. surge arrester has successfully passed the "Operating Interface AC Withstand Test" per IEEE Std 386™-2006 standard. This test verifies the POSI-BREAK M.O.V.E. surge arrester will greatly reduce the partial vacuum related flashovers in the field.

## Production tests

Tests conducted in accordance with IEEE Std 386™-2006 and IEEE Std C62.11™-2005 standards.

- Corona Extinction Voltage Level
- AC 60 Hz 1 Minute Withstand
- AC 60 Hz Watts Loss on Assembly

Tests conducted in accordance with Eaton requirements:

- Physical Inspection
- Periodic Dissection
- Arrester Assembly:
  - Voltage at 1 mA
- Periodic Fluoroscopic Analysis

### Production tests of MOV blocks

A complete production test program ensures a quality product. Each metal oxide varistor receives a series of electrical tests. Quality is demonstrated by a series of destructive tests performed on every batch of varistors. Listed are the tests performed on the varistors:

- 100% Physical Inspection
- 100% Discharge Voltage test
- 100%  $V_{1mA/cm^2}$
- 100% Leakage Current at 80% of  $V_{1mA/cm^2}$  Voltage (Watts Loss)
- Batch High-current, Short-duration test
- Batch Thermal Stability test
- Batch Aging test

### General application recommendations

The rating of an arrester is the maximum power frequency line-to-ground voltage at which the arrester is designed to pass an operating duty-cycle test. Table 2 provides a general application guide for the selection of the proper arrester rating for a given system voltage and system grounding configuration as outlined in the IEEE Std C62.22™ standard application guide.

Under fault conditions and other system anomalies, higher voltages can be experienced by the arrester. To ensure that the arrester ratings will not be exceeded, Eaton application engineers are available to make recommendations. The following information is normally required:

1. System maximum operating voltage.
2. System grounding conditions.
  - A. For four-wire circuits, grounding conditions depend upon whether the system is multi-grounded, whether it has a neutral impedance and whether common primary and secondary neutrals are used.
  - B. For three-wire circuits, grounding conditions depend upon whether the system is solidly grounded at the source, grounded through neutral impedance at the source transformers or ungrounded.

Consult your Eaton representative to have your individual system application needs studied.

### Protective characteristics

The protective characteristics of the POSI-BREAK M.O.V.E. surge arresters are shown in Table 1.

**Table 1. Electrical Ratings and Characteristics**

Duty Cycle Voltage Rating (kV)	MCOV (kV)	Equivalent Front-of-Wave (kV crest)*	Maximum Discharge Voltage (kV crest) 8/20 $\mu$ s Current Wave				
			1.5 kA	3 kA	5 kA	10 kA	20 kA
3	2.55	11.0	9.0	9.7	10.4	11.4	13.0
6	5.1	22.0	18.0	19.4	20.8	22.7	26.0
9	7.65	31.7	26.0	28.0	30.0	32.8	37.4
10	8.4	33.0	27.0	29.1	31.2	34.1	38.9
12	10.2	41.5	33.9	36.6	39.2	42.9	48.9
15	12.7	51.8	42.4	45.7	49.0	53.6	61.1
18	15.3	62.2	50.9	54.9	58.8	64.3	73.4
21	17.0	66.0	54.0	58.2	62.4	68.2	77.9

\* Equivalent front-of-wave voltage is the expected discharge voltage of the arrester when tested with a 5 kA current surge cresting in 0.5  $\mu$ s.

**Table 2. Commonly Applied Voltage Ratings of POSI-BREAK M.O.V.E. Surge Arrester**

System Voltage (kV rms)		Commonly Applied Arrester Duty-cycle (MCOV) Voltage Rating (kV rms) on Distribution Systems		
Nominal Voltage	Maximum Voltage Range B	Four-Wire Multi-grounded Neutral Wye	Three-Wire Low Impedance Grounded	Three-Wire High Impedance Grounded
2400	2540	—	—	3 (2.55)
4160 Y/2400	4400 Y/2540	3 (2.55)	6 (5.1)	6 (5.1)
4160	4400	—	—	6 (5.1)
4800	5080	—	—	6 (5.1)
6900	7260	—	—	9 (7.65)
8320 Y/4800	8800 Y/5080	6 (5.1)	9 (7.65)	—
12 000 Y/6930	12 700 Y/7330	9 (7.65)	12 (10.2)	—
12 470 Y/7200	13 200 Y/7620	9 (7.65) or 10 (8.4)	15 (12.7)	—
13 200 Y/7620	13 970 Y/8070	10 (8.4)	15 (12.7)	—
13 800 Y/7970	14 520 Y/8380	10 (8.4) and 12 (10.2)	15 (12.7)	—
13 800	14 520	—	—	18 (15.3)
20 780 Y/12 000	22 000 Y/12 700	15 (12.7)	21 (17.0)	—
22 860 Y/13 200	24 200 Y/13 970	18 (15.3)	—	—
23 000	24 340	—	—	—
24 940 Y/14 400	26 400 Y/15 240	18 (15.3)	—	—
27 600 Y/15 935	29 255 Y/16 890	21 (17.0)	—	—

### Temporary overvoltage (TOV) capability

The Temporary Overvoltage (TOV) capability of the POSI-BREAK M.O.V.E. surge arrester is shown in Figure 2.

### Performance test characteristics

The POSI-BREAK M.O.V.E. surge arrester consistently withstands the following design tests as described by IEEE Std C62.11™ standard:

- **Duty Cycle:**  
22 current surges of 5 kA crest  
8/20 μs waveshape.
- **High-Current, Short-Duration Discharge:**  
2 current surges of 40 kA crest  
4/10 μs waveshape.
- **Low-Current, Long-Duration Discharge:**  
20 current surges of 75 A crest  
2000 μs rectangular wave duration.

Following each of these tests, the arresters remain thermally stable as verified by:

- Continually decreasing power values during a thirty minute power monitoring period.
- No evidence of physical or electrical deterioration.

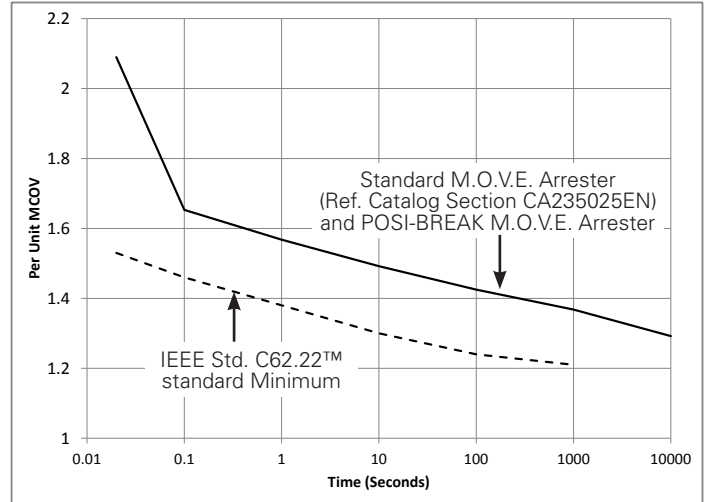

Figure 2. Temporary overvoltage curve. No prior duty at 85° C ambient.

Table 3. POSI-BREAK M.O.V.E. Surge Arrester Dimensions

Duty Cycle (kV)	MCOV Rating (kV)	Dimensions in./(mm)		
		A	B	C
3	2.55	8.5 (216)	7.0 (178)	7.9 (201)
6	5.1	8.5 (216)	7.0 (178)	7.9 (201)
9	7.65	8.5 (216)	7.0 (178)	7.9 (201)
10	8.4	8.5 (216)	7.0 (178)	7.9 (201)
12	10.2	8.5 (216)	7.0 (178)	7.9 (201)
15	12.7	8.5 (216)	7.0 (178)	7.9 (201)
18	15.3	8.5 (216)	7.0 (178)	7.9 (201)
21	17.0	8.5 (216)	7.0 (178)	7.9 (201)

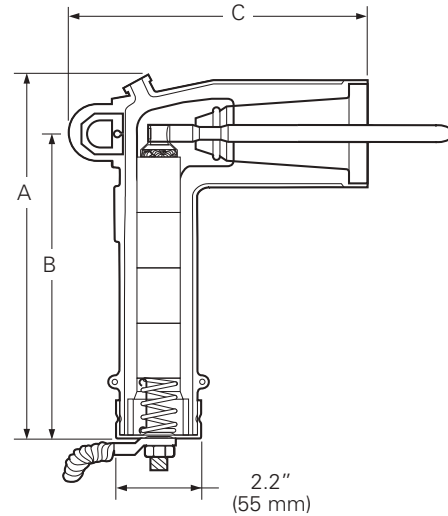

Figure 3. Dimensional information of POSI-BREAK M.O.V.E. surge arrester (refer to Table 4).

Note: Dimensions given are for reference only.

Table 4. UltraQUIK Catalog Numbering System

### UltraQUIK selection and ordering guide

1	2	3	4	5	6	7	8	9	10
P	L	E	A	2	2	5	N	1	8

#### Catalog Number Digits:

- 1 = "P", POSI-BREAK
- 2 = "L", Loadbreak
- 3 & 4 = "EA", Elbow Arrester
- 5, 6 & 7 = Elbow Class: "225", 200 A, 25 kV
- 8 = "N", Gapless
- 9 & 10 = Arrester Duty Cycle Rating: 03, 06, 09, 10, 12, 15, 18, or 21

#### Ordering information

To order a POSI-BREAK M.O.V.E. surge arrester, determine the arrester maximum continuous operating voltage (MCOV) rating for the intended application using Table 2 and determine the appropriate catalog number based on the catalog numbering system outlined above. Contact your Eaton representative for applications not listed.

#### Additional information

Refer to the following reference literature for additional information:

- CA650078EN, 200 A 15 kV Class Loadbreak Rotatable Feedthru Insert Catalog Section
- CA650077EN, 200 A 25 kV Class Rotatable Feedthru Insert Catalog Section
- CA650017EN, 600 A 15 kV Class T-OP II Deadbreak Connector Catalog Section
- CA650059EN, 600 A 25 kV Class T-OP II Deadbreak Connector Catalog Section
- CP9314, Certified Test Report Summary

This page intentionally left blank.

This page intentionally left blank.

**Eaton**  
1000 Eaton Boulevard  
Cleveland, OH 44122  
United States  
Eaton.com

**Eaton's Power Systems Division**  
2300 Badger Drive  
Waukesha, WI 53188  
United States  
Eaton.com/cooperpowerseries

© 2017 Eaton  
All Rights Reserved  
Printed in USA  
Publication No. CA235028EN

Eaton is a registered trademark.  
All other trademarks are property  
of their respective owners.

For Eaton's Cooper Power series product  
information call 1-877-277-4636 or visit:  
[www.eaton.com/cooperpowerseries](http://www.eaton.com/cooperpowerseries).