



## The M-Force three-phase switch is robust, reliable and easy to use

Only Eaton's Cooper Power™ series M-Force™ distribution class switches are designed with reverse loop contacts—typically just found in transmission class switches.

This gang-operated, factory unitized three-phase overhead loadbreak switch is offered in distribution voltage classifications of 15 kV, 25 kV, and 35 kV and may be used for line sectionalizing, paralleling, by-passing or isolating.

Eaton's improved M-Force three-phase gang-operated loadbreak switch, complete with a multitude of redesigned features, meets the tough reliability needs of distribution systems.

### **Robust design increases reliability**

- UltraSIL™ polymer insulators
  - No chipping
  - No cracking
  - Lighter weight
- Stainless steel bell crank operating mechanism
- Better corrosion resistance leads to longer life and smoother operation

- Stronger Reliabreak™ interrupter
  - Less prone to shipping damage
  - Improved contact life allows for more reliable switching operations
- Better connection with reverse loop contacts
  - Typically only found in substation switches
  - Runs cooler, prolonging switch life
  - High contact pressure maintained during fault conditions

### **Safer and easier to use**

- Lighter weight polymer insulator
- Smooth operating spindle assembly
  - Improved collar and bearing design provide smoother motion
- Stronger spindle is more durable
- Requires less force to open and close switch

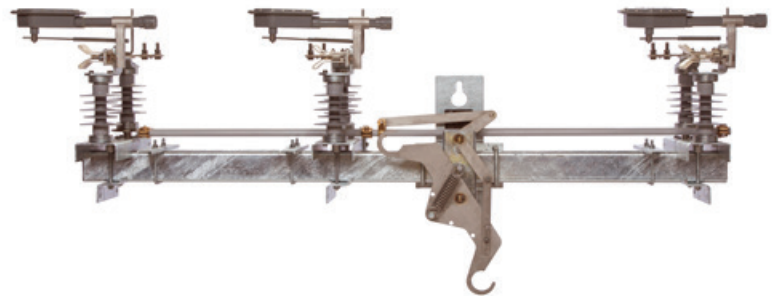

**EATON**

*Powering Business Worldwide*

# Ensure switching integrity on your distribution system with the M-Force switch

## Reverse Loop Contacts

The M-Force switch uses reverse loop contacts, normally only seen in substation equipment. Current flows through the two parallel inner segments of the reverse loop contacts in the same direction, increasing contact pressure.

These contacts maintain cooler running temperatures and exhibit longer life. Reverse loop contacts achieve added reliability and allow for high contact pressure to be maintained during fault conditions. These contacts and switch blade show excellent resistance to pitting and distortion, even under severe momentary overload.

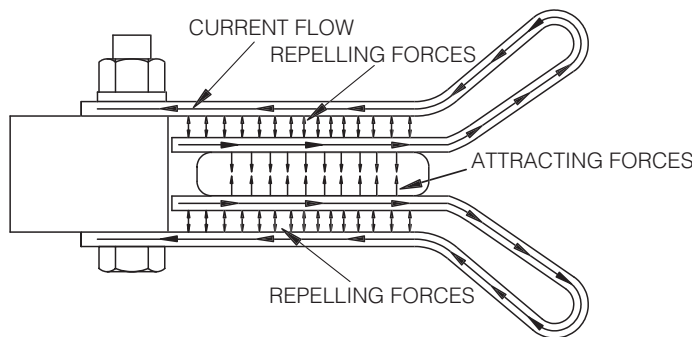

## Rotating Spindle

The rotating insulator was redesigned to require less force to operate. The spindle now uses a collar, and is less susceptible to position change than rotating insulators with retaining C-rings. Oil impregnated bushings ensure as little force as possible is necessary for opening and closing of the switch blade, in addition to providing exceptionally smooth operation.

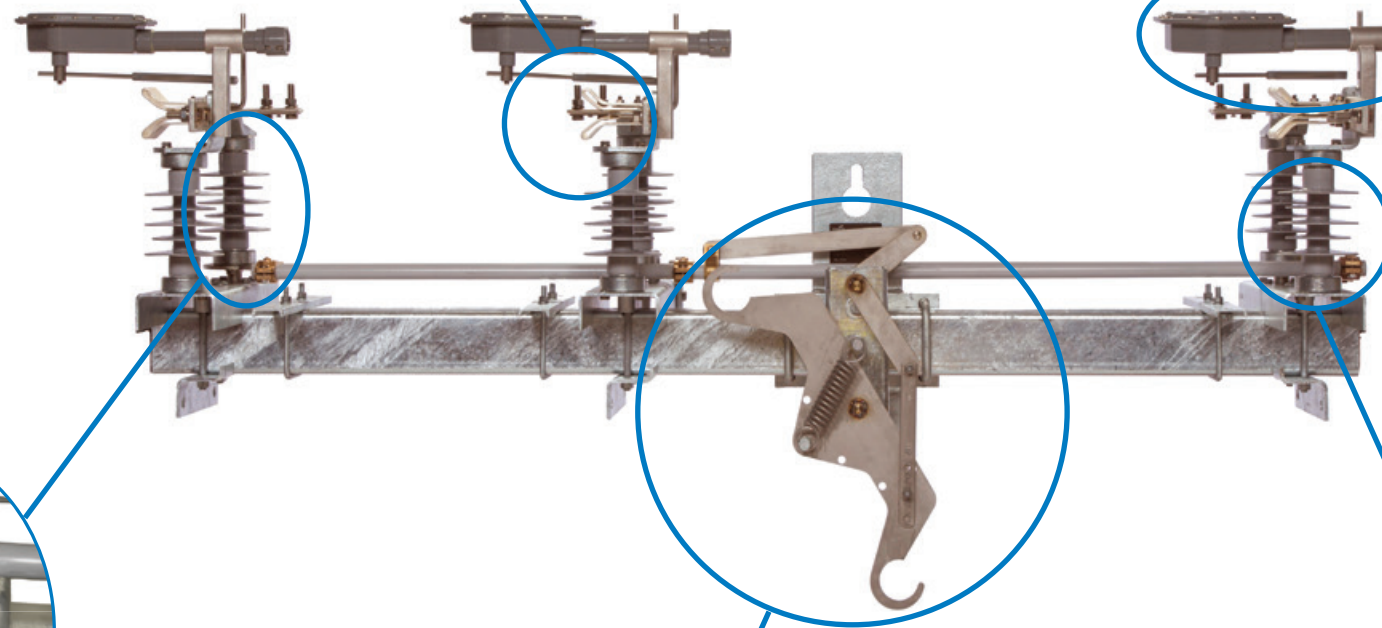
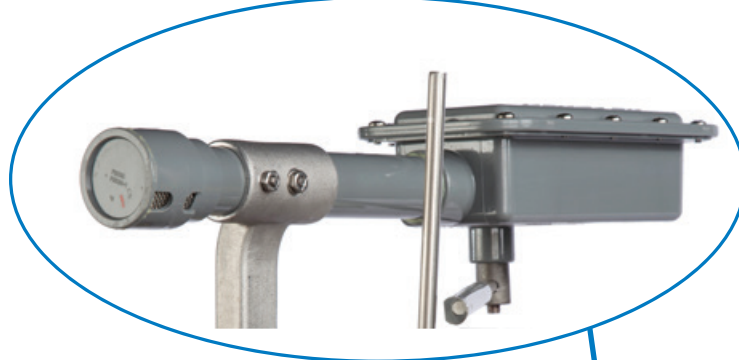
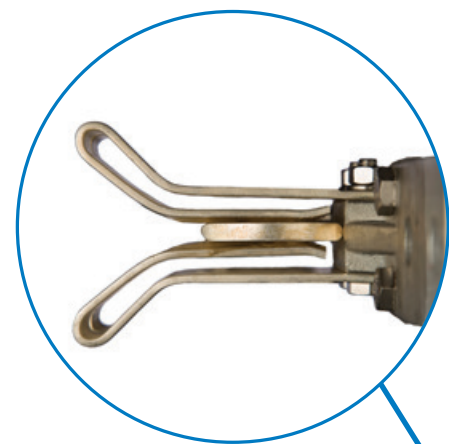
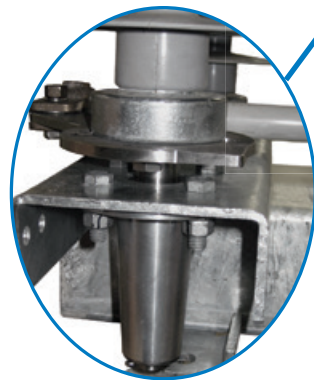

## Stainless Steel Bell Crank

The bell-crank was redesigned to include fewer parts and is now made from stainless steel. Bearings were added to aid in smoother operation, and stainless steel components exhibit better corrosion resistance than galvanized steel.

The switch can be operated in several different manners: a reciprocating mechanism, torsional mechanism, or with a hookstick bell-crank. Reciprocating and torsional mechanisms can be specified from an assortment of insulated control rod types.

## Reliabreak Interrupter

**Snuffer tubes** - Redesigned tubes are now stronger and much more robust.

**Reliabreak contacts** - Redesigned high-performance tungsten alloy contacts create consistent operation and provide unsurpassed contact life.

**Arc follower/snuffer** - The arc follower and arc snuffer employ the same field-proven technology developed by the inventors of loadbreak elbows. The arc ablatives material produces gases during switching operations to quickly extinguish any arcing.

**Exhaust cap** - The exhaust cap is the relief port for the arc extinguishing gases produced during loadbreak operations.

**Enclosure mechanism** - The robust mechanism within the Reliabreak enclosure generates high arc extinguishing speed to reduce arcing time.

**Copper driving rod** - Low-resistance copper alloy carries current during switching operations.

## Reliabreak Holder

The Reliabreak holder is now cast and made of fewer components to offer simpler, more consistent alignment. If the Reliabreak catch needs replacement, only one adjustment is needed.



## UltraSIL™ Polymer Insulators

M-force switches now include standard polymer phase insulators. These insulators reduce the overall weight of the switch and offer enhanced hydrophobicity to protect against flashovers, as has been demonstrated by the same technology in Eaton's Cooper Power series UltraSIL™ VariStar™ polymer surge arresters. Insulators are also available in porcelain or cycloaliphatic material.

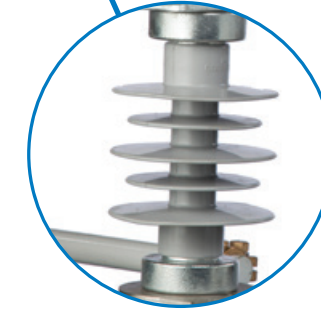

## Mounting Configurations

M-force switches come in a variety of mounting configurations to accommodate almost any application. Many styles offer an option for California General Order 95 (GO95) spacing for those applications that require specific conductor clearances. Options include horizontal, horizontal poletop, vertical riser, triangular, phase-over-phase, and underhung configurations.

**NOTE:** See catalog CA008004EN for a complete listing of configurations and dimensions.

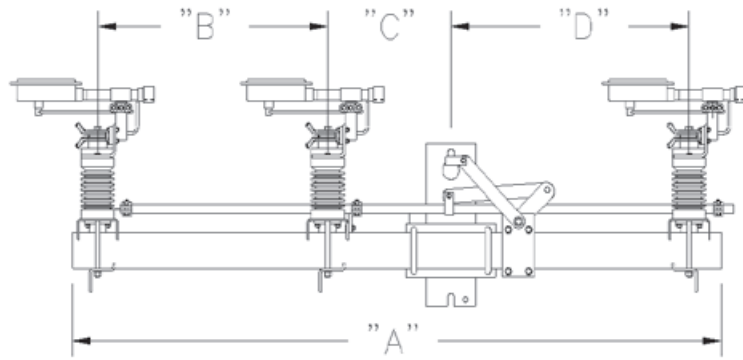

Figure 1. Horizontal switch configuration.

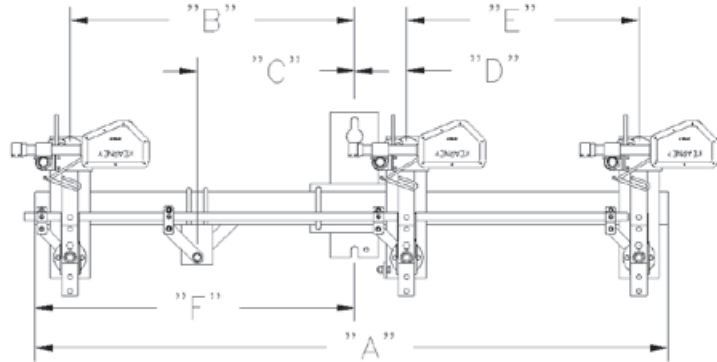

Figure 2. Vertical switch configuration.

Table 1. Dimensional Information

Dim.	Horizontal						Vertical (Riser)					
	Standard			G095			Standard			G095		
	15.5 kV	27 kV	38 kV	15.5 kV	27 kV	38 kV	15.5 kV	27 kV	38 kV	15.5 kV	27 kV	38 kV
A	79"	88"	119"	97"	108"	126"	79"	88"	97"	108"	119"	126"
B	28"	33"	42"	28"	33"	42"	35.5"	40"	45"	49.5"	56"	54.5"
C	15"	15"	18"	24"	24"	24"	19.5"	19.5"	19.5"	19.5"	19.5"	19.5"
D	29"	33"	52"	38"	43.5"	52.5"	6.5"	6.5"	6.5"	22"	22.5"	22.5"
E	N/A	N/A	N/A	N/A	N/A	N/A	29"	33.5"	45"	29"	33.5"	42"
F	N/A	N/A	N/A	N/A	N/A	N/A	39.5"	45"	48.5"	53.5"	59.5"	58"

Table 2. Electrical Characteristics

	Max	BIL	Cont. Current	Loadbreak	Momentary*	3 Second	Fault Close (ASM)
14.4 kV	15.5 kV	110 kV	600 A**	50 @ 600 A***	40 kA Asy. rms	25 kA Sym. rms	1 @ 20 kA, 3 @ 15 kA
25 kV	27 kV	150 kV	600 A**	50 @ 600 A***	40 kA Asy. rms	25 kA Sym. rms	1 @ 20 kA, 3 @ 15 kA
34.5 kV	38 kV	200 kV	900 A	10 @ 900 A	40 kA Asy. rms	25 kA Sym. rms	1 @ 20 kA, 3 @ 15 kA

\* Momentary peak current is 65 kA.

\*\* 900 A optional.

\*\*\* If optional rating selected, 10 operations at 900 A.

**Eaton**  
1000 Eaton Boulevard  
Cleveland, OH 44122  
United States  
Eaton.com

**Eaton's Cooper Power Systems Division**  
2300 Badger Drive  
Waukesha, WI 53188  
United States  
Eaton.com/cooperpowerseries

© 2015 Eaton  
All Rights Reserved  
Printed in USA  
Publication No. PA008011EN  
June 2015

For Eaton's Cooper Power series product information, call 1-877-277-4636 or visit: [www.eaton.com/cooperpowerseries](http://www.eaton.com/cooperpowerseries)