

## High-voltage primary bushings installation instructions

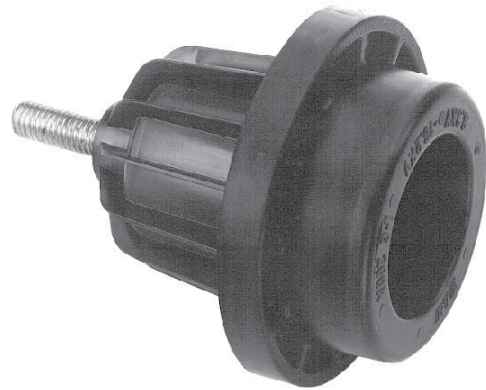

## **DISCLAIMER OF WARRANTIES AND LIMITATION OF LIABILITY**

The information, recommendations, descriptions and safety notations in this document are based on Eaton Corporation's ("Eaton") experience and judgment and may not cover all contingencies. If further information is required, an Eaton sales office should be consulted. Sale of the product shown in this literature is subject to the terms and conditions outlined in appropriate Eaton selling policies or other contractual agreement between Eaton and the purchaser.

THERE ARE NO UNDERSTANDINGS, AGREEMENTS, WARRANTIES, EXPRESSED OR IMPLIED, INCLUDING WARRANTIES OF FITNESS FOR A PARTICULAR PURPOSE OR MERCHANTABILITY, OTHER THAN THOSE SPECIFICALLY SET OUT IN ANY EXISTING CONTRACT BETWEEN THE PARTIES. ANY SUCH CONTRACT STATES THE ENTIRE OBLIGATION OF EATON. THE CONTENTS OF THIS DOCUMENT SHALL NOT BECOME PART OF OR MODIFY ANY CONTRACT BETWEEN THE PARTIES.

In no event will Eaton be responsible to the purchaser or user in contract, in tort (including negligence), strict liability or otherwise for any special, indirect, incidental or consequential damage or loss whatsoever, including but not limited to damage or loss of use of equipment, plant or power system, cost of capital, loss of power, additional expenses in the use of existing power facilities, or claims against the purchaser or user by its customers resulting from the use of the information, recommendations and descriptions contained herein. The information contained in this manual is subject to change without notice.

# Contents

## SAFETY INFORMATION

|                          |    |
|--------------------------|----|
| Safety information ..... | iv |
|--------------------------|----|

## PRODUCT INFORMATION

|   |   |
|---|---|
| Introduction .....                      | 1 |
| Acceptance and initial inspection ..... | 1 |
| Handling and storage .....              | 1 |
| Standards .....                         | 1 |

## INSTALLATION INSTRUCTIONS

|                             |   |
|-----------------------------|---|
| Electrical ratings .....    | 2 |
| Mounting requirements ..... | 2 |
| Dielectric clearances ..... | 3 |
| Torque requirements .....   | 3 |



## Safety for life



Eaton meets or exceeds all applicable industry standards relating to product safety in its Cooper Power™ series products. We actively promote safe practices in the use and maintenance of our products through our service literature, instructional training programs, and the continuous efforts of all Eaton employees involved in product design, manufacture, marketing, and service.

We strongly urge that you always follow all locally approved safety procedures and safety instructions when working around high voltage lines and equipment, and support our “Safety For Life” mission.

## Safety information

The instructions in this manual are not intended as a substitute for proper training or adequate experience in the safe operation of the equipment described. Only competent technicians who are familiar with this equipment should install, operate, and service it.

A competent technician has these qualifications:

- Is thoroughly familiar with these instructions.
- Is trained in industry-accepted high and low-voltage safe operating practices and procedures.
- Is trained and authorized to energize, de-energize, clear, and ground power distribution equipment.
- Is trained in the care and use of protective equipment such as arc flash clothing, safety glasses, face shield, hard hat, rubber gloves, clampstick, hotstick, etc.

Following is important safety information. For safe installation and operation of this equipment, be sure to read and understand all cautions and warnings.

### Hazard Statement Definitions

This manual may contain four types of hazard statements:

#### DANGER

Indicates an imminently hazardous situation which, if not avoided, will result in death or serious injury.

#### WARNING

Indicates a potentially hazardous situation which, if not avoided, could result in death or serious injury.

#### CAUTION

Indicates a potentially hazardous situation which, if not avoided, may result in minor or moderate injury.

#### CAUTION

Indicates a potentially hazardous situation which, if not avoided, may result in equipment damage only.

### Safety instructions

Following are general caution and warning statements that apply to this equipment. Additional statements, related to specific tasks and procedures, are located throughout the manual.

#### DANGER

**Hazardous voltage. Contact with hazardous voltage will cause death or severe personal injury. Follow all locally approved safety procedures when working around high- and low-voltage lines and equipment.**

G103.3

#### WARNING

**Before installing, operating, maintaining, or testing this equipment, carefully read and understand the contents of this manual. Improper operation, handling or maintenance can result in death, severe personal injury, and equipment damage.**

G101.0

#### WARNING

**This equipment is not intended to protect human life. Follow all locally approved procedures and safety practices when installing or operating this equipment. Failure to comply can result in death, severe personal injury and equipment damage.**

G102.1

#### WARNING

**Power distribution and transmission equipment must be properly selected for the intended application. It must be installed and serviced by competent personnel who have been trained and understand proper safety procedures. These instructions are written for such personnel and are not a substitute for adequate training and experience in safety procedures. Failure to properly select, install or maintain power distribution and transmission equipment can result in death, severe personal injury, and equipment damage.**

G122.3

---

**WARNING**

All associated apparatus must be de-energized and all voltage sources removed during installation, removal or maintenance. Improper operation, handling, or maintenance can result in death or severe personal injury.

---

**CAUTION**

Use red or blue shipping cap provided to protect bushings from physical damage and contaminants. This shipping cap should not be used for insulating a bushing when energizing the unit.

---

**Product information**

**Introduction**

Eaton's Cooper Power™ series high-voltage (primary) bushings are designed for external mounting (and removal) on pad-mounted transformers, filled with transformer oil, Envirotemp™ FR3™ fluid, or an approved equivalent. Modified versions of these bushings are also available for applications with SF<sub>6</sub>. They are to be installed inside cubicles. High-voltage (primary) bushings are used for connecting the high-voltage cables outside of the tank to the primary leads on the inside of the tank through the tank wall.

**Read this manual first**

Read and understand the contents of this manual and follow all locally approved procedures and safety practices before installing or operating this equipment.

**Additional information**

These instructions cannot cover all details or variations in the equipment, procedures, or process described nor provide directions for meeting every possible contingency during installation, operation, or maintenance. For additional information, contact your representative.

**Acceptance and initial inspection**

Each high-voltage bushing is in good condition when accepted by the carrier for shipment. Upon receipt, inspect the shipping container for signs of damage. Unpack the high-voltage bushing and inspect it thoroughly for damage incurred during shipment. If damage is discovered, file a claim with the carrier immediately.

**Handling and storage**

Be careful during handling and storage of the high-voltage bushing to minimize the possibility of damage. If the high-voltage bushing is to be stored for any length of time prior to installation, provide a clean, dry storage area.

**Standards**

ISO 9001 Certified Quality Management System

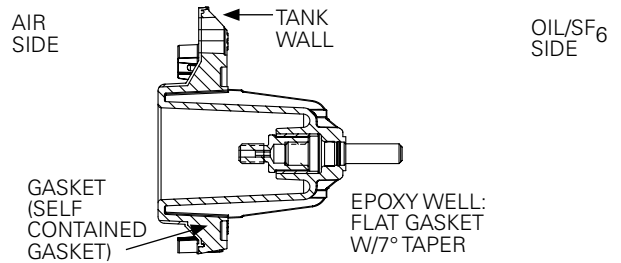

**Figure 1. 200 A, 15, 25, 28 and 35 kV Bushing Well (shown with removable stud and Tri-Clamp Well.)**

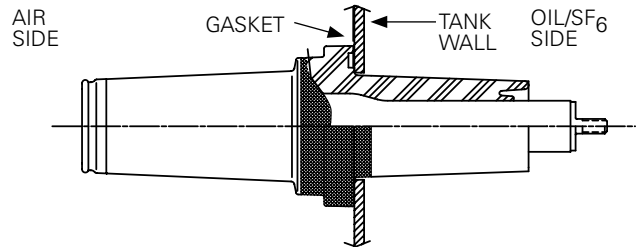

**Figure 2. 200 A, Loadbreak, One Piece Bushing, 35 kV.**

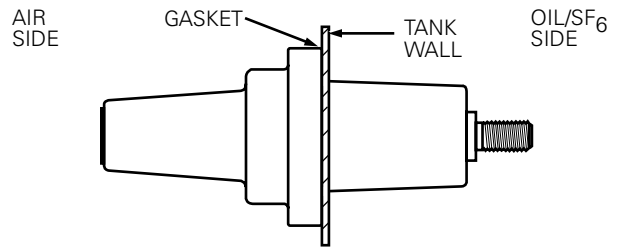

**Figure 3. 600 A, Deadbreak, One Piece Bushing, 15, 25 and 35 kV (15/25 kV bushing shown).**

# Installation procedure

**Table 1. Electrical Ratings**

| kV Class     | Description                        | Voltage Withstand  |           | Continuous Current Rating* | Impulse Withstand kV BIL | Minimum Corona Voltage | Maximum Rating |      | Voltage (RMS) |
|--------------|------------------------------------|--------------------|-----------|----------------------------|--------------------------|------------------------|----------------|------|---------------|
|              |                                    | AC 60 Hz 1 Min RMS | DC 15 Min |                            |                          |                        | P-G            | P-P  |               |
| 15, 25, & 28 | 200 A Bushing Well (HTN and epoxy) | 40                 | 78        | 200 A                      | 125                      | 21.5                   | 16.2           | –    |               |
| 35           | Tri-Clamp, 200 A Bushing Well      | 50                 | 103       | 200 A                      | 150                      | 26                     | 21.1           | –    |               |
| 35           | 1-Pc, 200 A Loadbreak Bushing      | 50                 | 103       | 200 A                      | 150                      | 26                     | 21.1           | 36.6 |               |
| 15/25        | 1-Pc, 600 A Deadbreak Bushing      | 40                 | 78        | 600/900 A                  | 125                      | 19                     | 15.2           | –    |               |
| 35           | 1-Pc, 600 A Deadbreak Bushing      | 50                 | 103       | 600/900 A                  | 150                      | 26                     | 21.1           | –    |               |
| 35           | 1-Pc, 600 A Deadbreak Bushing      | 70                 | 114       | 600/900 A                  | 200                      | 26                     | 21.1           | –    |               |

\* 600 A with aluminum components and 900 A with copper components.

## Mounting requirements

Sidewall-mounted with the internal stud end completely immersed under oil or SF<sub>6</sub>. All parts should be inspected for damage before using. Clamping studs must be welded around the bushing hole to accommodate either a 3-hole or 4-hole clamp. Install the gasket over the bushing assembly through the tank hole and place the clamp\* over the welded tank studs against the bushing flange. Install a plated lock-washer and nut onto each stud and tighten to recommended torque. The Tri-Clamp well should have a plated flatwasher, lock washer and nut. Tighten to recommended torque. Connect internal lead to the internal bushing stud using recommended torque and procedures. See Figure 5.

\*One-piece molded (Tri-Clamp) bushing well does not require a clamp.

**Table 2. Tank Hole (Ref. Figure 4) 4-Stud Square Clamp**

| kV Class    | Description                                    | "A"*** Tank Hole Size (Dia.) | "B" C-C Stud Spacing                      |
|-------------|--|------------------------------|---|
| 15 & 25     | 200 A Bushing Well with a 2.19" Diameter Shank | 2.25" (57 mm)                | 2.75", 3.00", or 3.25" (70, 76, or 83 mm) |
| 15, 25 & 35 | 200 A Bushing Well with a 2.50" Diameter Shank | 2.56" (65 mm)                | 2.75", 3.00", or 3.25" (70, 76, or 83 mm) |
| 35          | 200 A Loadbreak 3Ø                             | 2.75" (70 mm)                | 3.87" (98 mm)                             |
| 15, 25 & 35 | 600 A Deadbreak                                | 2.56" (65 mm)                | 3.43" (87 mm)                             |

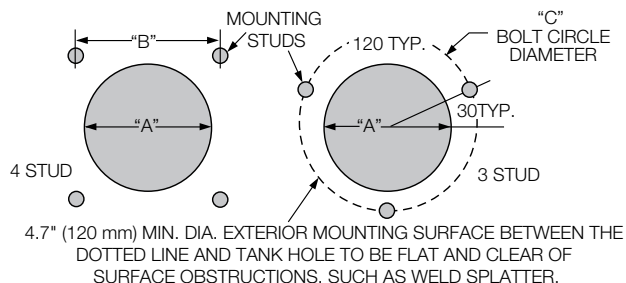

**Figure 4. Tank mounting hole for 3- and 4-hole stud configuration.**

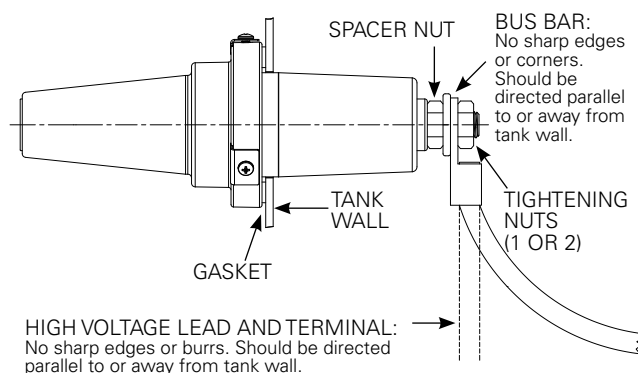

**Figure 5. High voltage bushing (all, including bushing well) internal lead training. (Bushing shown-35 kV, 600 A deadbreak.)**

**Table 3. 3-Stud Triangular Bushing Clamp or One Piece Tri-Clamp Bushing Well**

| kV Class     | Description   | "A" Tank Hole Size (Dia.) | "C" Bolt Circle (Dia.) |
|--------------|---|---------------------------|------------------------|
| 15 & 25      | 200 A Bushing Well with a 2.19" Diameter Shank      | 2.25" (57 mm)             | 4.68" (119 mm)         |
| 15, 25, & 35 | All 200 A Bushing Wells with a 2.50" Diameter Shank | 2.56" (65 mm)             | 4.68" (119 mm)         |
| 35           | 200 A Loadbreak                                     | 2.75" (70 mm)             | 4.68" (119 mm)         |

**Note:** Recommended Tank Stud Dimension 3/8" - 16 x 1.625" (41 mm).

\*\* "A" Tankhole Size Tolerance is -0.00"/+0.10" (-0/+2.5 mm)

## Dielectric clearances

Oil level and bushing clearance to other internal components to be suitable for voltage class of equipment and components.

Minimum underoil clearances:

| kV BIL | Clearance to Ground or Between Phase |
|--------|--------------------------------------|
| 95     | 1.1" (28 mm)                         |
| 125    | 1.5" (38 mm)                         |
| 150    | 2.5" (64 mm)                         |
| 200    | 3.5" (89 mm)                         |

## Torque requirements

### Clamping Flange

- For 3-hole and 4-hole clamp torque requirements, see Table 4.
- Molded (one-piece) Tri-Clamp bushing well should be tightened to 70-80 in-lbs torque.

**Note:** For SF<sub>6</sub> bushings torque should be held at 50-60 in-lbs.

Hold clamping flange against the bushing and tighten all nuts by hand against the lockwashers. With a torque wrench, tighten nuts down gradually, alternately in increments until the recommended torque is obtained. On 4-hole stud clamp tighten nuts in a diagonal sequence.

Mounting studs should be free of nicks, paint, dirt and weld splatter. They must also be correctly positioned to avoid binding on the clamping flange.

### Internal (underoil or SF<sub>6</sub>) bushing stud

Brass nuts are recommended for copper threads and aluminum nuts for aluminum threads. Nuts for internal bushing studs should be tightened as follows:

|                               |              |
|-------------------------------|--------------|
| 200 A, 3/8 - 16 brass nuts    | 12-15 ft-lbs |
| 600 A, 5/8 - 11 brass nuts    | 50-65 ft-lbs |
| 600 A, 5/8 - 11 aluminum nuts | 50-65 ft-lbs |

Install nut onto the internal bushing stud. Place high voltage lead terminal with crimped ring torque terminal onto the bushing stud against the nut. Place a second nut onto bushing stud and tighten to the recommended torque. An optional locking nut may also be placed on the stud and tightened to the recommended torque.

### Removable stud bushing well

The part number for the removable stud replacement kit is 2639081B01B. For replacement instructions of the removable stud from bushing well/insert, refer to S800-34-2.

### Grounding of bushing insert

It is recommended that, when a bushing well insert is installed into the well, the Insert be grounded by attaching a #14 AWG or equivalent wire between one of the three mounting studs to one of the tabs on the Insert (see MN650015EN). This can be accomplished by wrapping the wire around one of the studs and securing with an additional 3/8" nut. Other options are available. Please contact your Eaton representative for more information.

**Table 4. Torque Requirements-Clamping Flange**

| kV Class     | Description                                    | Torque (in-lbs) |
|--------------|--|-----------------|
| 15 & 25      | 200 A Bushing Well with a 2.19" Diameter Shank | 40-60           |
| 15, 25, & 35 | 200 A Bushing Well with a 2.50" Diameter Shank | 40-60           |
| 35           | 200 A Loadbreak 3Ø                             | 40-90           |
| 15, 25, & 35 | 600 A Deadbreak                                | 40-90           |



**Eaton**  
1000 Eaton Boulevard  
Cleveland, OH 44122  
United States  
Eaton.com

**Eaton's Cooper Power Systems  
Division**  
2300 Badger Drive  
Waukesha, WI 53188  
Eaton.com/cooperpowerseries

© 2016 Eaton  
All Rights Reserved  
Printed in USA  
Publication No. MN800008EN Rev 00  
(Replaces S800352 Rev 04)

Eaton is a registered trademark.

All trademarks are property  
of their respective owners.

For Eaton's Cooper Power series product  
information call 1-877-277-4636 or visit:  
[www.eaton.com/cooperpowerseries](http://www.eaton.com/cooperpowerseries).