

ELSG fuse holder

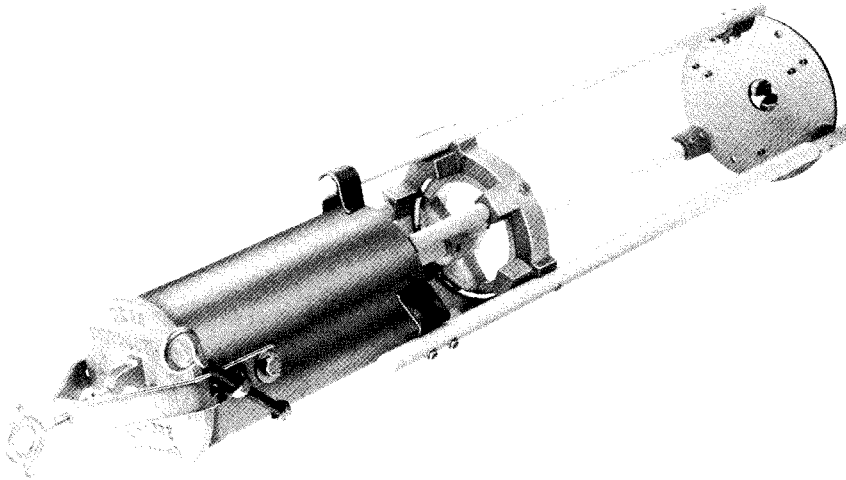

General

Eaton mounts its Cooper Power™ series ELSG current-limiting fuses in its Cooper Power series oil-filled distribution apparatus ELSG fuse holder, a non-loadbreak device. The handle assembly and the upper contact cap guide finders provide the ease of hotstick operation for fuse removal for inspection and/or replacement.

Installation

An outer flange is welded to the apparatus sidewall. Internally a fuse holder is bolted to the flange. The fuse is mounted on the end of a handle assembly and inserted into the fuse holder. A bail assembly with gasket insures a tight seal from the environment.

EATON

Powering Business Worldwide

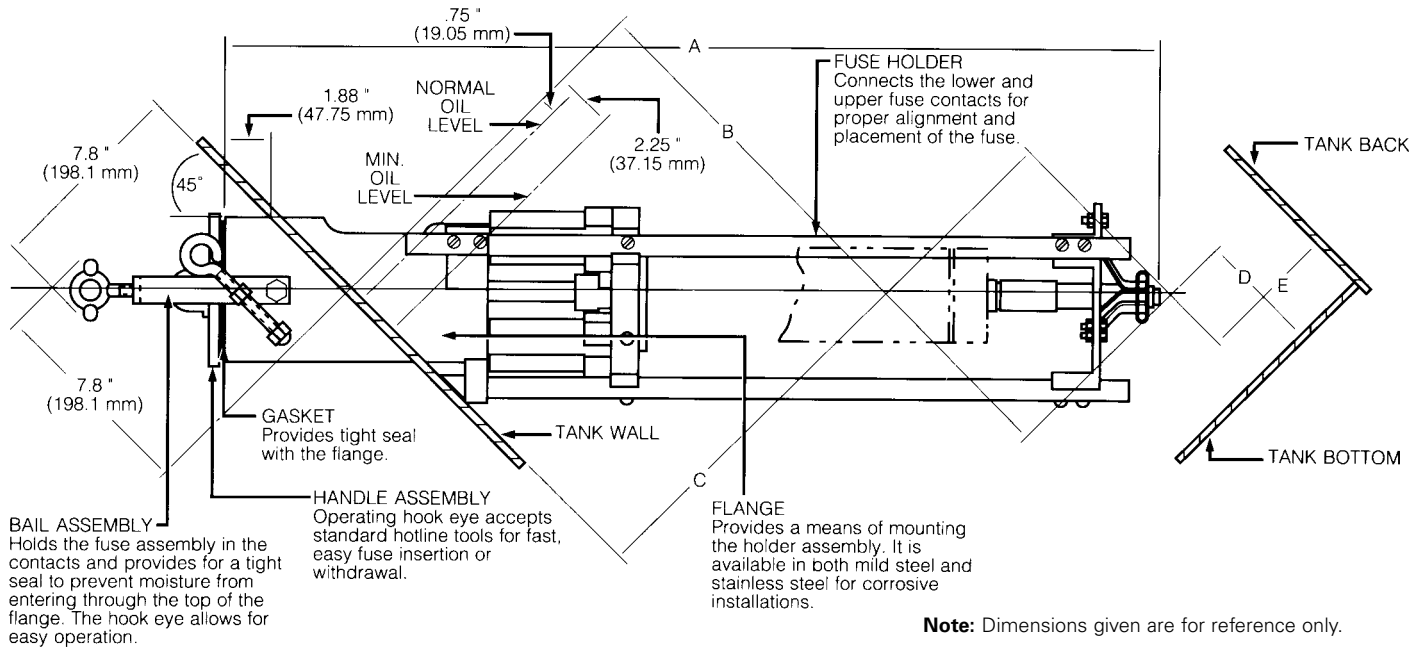

Figure 1. Dimensional information for ELSG Fuse Holder.

Table 1. Electrical Ratings and Characteristics

Voltage Rating (KV)	BIL Rating (kV)	Minimum Clearances (From centerline of fuse)	
		Phase-to-Phase	Phase-to-Ground
15	125	10.0" (254 mm)	6.0" (152.4 mm)
25	150	10.0" (254 mm)	10.0" (254 mm)
35	150	10.0" (254 mm)	10.0" (254 mm)

Table 2. ELSG Fuse Holder Dimensional Information

System Phase-to-Phase Nominal	A	B	C	D	E
15 kV	34.34 (872.24)	21.28 (540.51)	21.06 (534.93)	6.00 (152.40)	11.00 (279.40)
25 kV and 35 kV	36.40 (924.56)	22.74 (577.60)	22.52 (572.01)	9.50 (241.30)	12.50 (317.50)

Ordering information

To order an ELSG Fuse Holder, refer to Table 3.

Table 3. Assemblies

Description	Catalog Number
15 kV	
Mild Steel Assembly	KP3437322C1M
Stainless Steel Assembly	KP3437322C2M
25 kV and 35 kV	
Mild Steel Assembly	KP3437322C5M

Table 4. Replacement Parts

Description	Catalog Number
Bail Assembly	1637318C01
Handle Assembly	3437321C02
Mild Steel Flange	3438241B01
Stainless Steel Flange	3438241B02
15 kV Fuse holder for 15 kV	3437644C01
25 kV and 35 kV Fuse holder	3437644C02

Eaton
 1000 Eaton Boulevard
 Cleveland, OH 44122
 United States
 Eaton.com

Eaton's Cooper Power Systems Division
 2300 Badger Drive
 Waukesha, WI 53188
 United States
 Cooperpower.com

© 2015 Eaton
 All Rights Reserved
 Printed in USA
 Publication No. CA132019EN



Eaton and Cooper Power are valuable trademarks of Eaton in the U.S. and other countries. You are not permitted to use these trademarks without the prior written consent of Eaton.

For Eaton's Cooper Power series ELSG fuse holder product information call 1-877-277-4636 or visit: www.cooperpower.com.