

## DTS1242 Deadbreak Bolted Tee Connector: Interface C for Single Core Cable with Copper Wire Screen and Outer Sheath Installation Instructions



## **DISCLAIMER OF WARRANTIES AND LIMITATION OF LIABILITY**

The information, recommendations, descriptions and safety notations in this document are based on Eaton Corporation's ("Eaton") experience and judgment and may not cover all contingencies. If further information is required, an Eaton sales office should be consulted. Sale of the product shown in this literature is subject to the terms and conditions outlined in appropriate Eaton selling policies or other contractual agreement between Eaton and the purchaser.

THERE ARE NO UNDERSTANDINGS, AGREEMENTS, WARRANTIES, EXPRESSED OR IMPLIED, INCLUDING WARRANTIES OF FITNESS FOR A PARTICULAR PURPOSE OR MERCHANTABILITY, OTHER THAN THOSE SPECIFICALLY SET OUT IN ANY EXISTING CONTRACT BETWEEN THE PARTIES. ANY SUCH CONTRACT STATES THE ENTIRE OBLIGATION OF EATON. THE CONTENTS OF THIS DOCUMENT SHALL NOT BECOME PART OF OR MODIFY ANY CONTRACT BETWEEN THE PARTIES.

In no event will Eaton be responsible to the purchaser or user in contract, in tort (including negligence), strict liability or otherwise for any special, indirect, incidental or consequential damage or loss whatsoever, including but not limited to damage or loss of use of equipment, plant or power system, cost of capital, loss of power, additional expenses in the use of existing power facilities, or claims against the purchaser or user by its customers resulting from the use of the information, recommendations and descriptions contained herein. The information contained in this manual is subject to change without notice.

# Contents

<b>DISCLAIMER OF WARRANTIES AND LIMITATION OF LIABILITY</b> .....	<b>ii</b>
<b>SAFETY FOR LIFE</b> .....	<b>iv</b>
<b>SAFETY INFORMATION</b> .....	<b>iv</b>
Safety instructions .....	iv
<b>PRODUCT INFORMATION</b> .....	<b>1</b>
Introduction .....	1
Read this manual first .....	1
Additional information .....	2
Acceptance and initial inspection .....	2
Handling and storage .....	2
Standards .....	2
<b>INSTALLATION PROCEDURE</b> .....	<b>2</b>
Kit contents .....	2
Tools required .....	2
Cable preparation (1) .....	3
Adapter (2) .....	3
Crimp lugs (3) .....	4
Mechanical lugs (3) .....	4
Tee body (4) .....	5
Stud (5) .....	5
Tee (6) .....	5
Nut (7) .....	5
Plug (8) .....	5
Cap and earth wire (9) .....	5

# DTS1242 Deadbreak Bolted Tee Connector: Interface C for Single Core Cable with Copper Wire Screen and Outer Sheath



## Safety for life



Eaton meets or exceeds all applicable industry standards relating to product safety in its Cooper Power™ series products. We actively promote safe practices in the use and maintenance of our products through our service literature, instructional training programs, and the continuous efforts of all Eaton employees involved in product design, manufacture, marketing, and service.

We strongly urge that you always follow all locally approved safety procedures and safety instructions when working around high voltage lines and equipment, and support our “Safety For Life” mission.

## Safety information

The instructions in this manual are not intended as a substitute for proper training or adequate experience in the safe operation of the equipment described. Only competent technicians who are familiar with this equipment should install, operate, and service it.

A competent technician has these qualifications:

- Is thoroughly familiar with these instructions.
- Is trained in industry-accepted high and low-voltage safe operating practices and procedures.
- Is trained and authorized to energize, de-energize, clear, and ground power distribution equipment.
- Is trained in the care and use of protective equipment such as arc flash clothing, safety glasses, face shield, hard hat, rubber gloves, clampstick, hotstick, etc.

Following is important safety information. For safe installation and operation of this equipment, be sure to read and understand all cautions and warnings.

### Hazard Statement Definitions

This manual may contain four types of hazard statements:

---

**DANGER**

---

**Indicates an imminently hazardous situation which, if not avoided, will result in death or serious injury.**

---

**WARNING**

---

**Indicates a potentially hazardous situation which, if not avoided, could result in death or serious injury.**

---

**CAUTION**

---

**Indicates a potentially hazardous situation which, if not avoided, may result in minor or moderate injury.**

---

**CAUTION**

---

**Indicates a potentially hazardous situation which, if not avoided, may result in equipment damage only.**

---

### Safety instructions

Following are general caution and warning statements that apply to this equipment. Additional statements, related to specific tasks and procedures, are located throughout the manual.

---

**DANGER**

---

**Hazardous voltage. Contact with hazardous voltage will cause death or severe personal injury. Follow all locally approved safety procedures when working around high- and low-voltage lines and equipment.**

G103.3

---

**WARNING**

---

**Before installing, operating, maintaining, or testing this equipment, carefully read and understand the contents of this manual. Improper operation, handling or maintenance can result in death, severe personal injury, and equipment damage.**

G101.0

---

**WARNING**

---

**This equipment is not intended to protect human life. Follow all locally approved procedures and safety practices when installing or operating this equipment. Failure to comply can result in death, severe personal injury and equipment damage.**

G102.1

---

**WARNING**

---

**Power distribution and transmission equipment must be properly selected for the intended application. It must be installed and serviced by competent personnel who have been trained and understand proper safety procedures. These instructions are written for such personnel and are not a substitute for adequate training and experience in safety procedures. Failure to properly select, install or maintain power distribution and transmission equipment can result in death, severe personal injury, and equipment damage.**

G122.2

---

**⚠ DANGER**

All associated apparatus must be de-energized during any hands-on installation or maintenance. Failure to comply will result in death, severe personal injury and equipment damage.

---

**⚠ WARNING**

Eaton's Cooper Power series separable connector is designed to be operated in accordance with normal safe operating procedures. These instructions are not intended to supersede or replace existing safety and operating procedures. Separable connectors must be de-energized during operation or maintenance. Visible break and adequate grounding must be provided before cable work proceeds. Ensure that the connector is rated for the intended application before it is installed.

Separable connectors should be installed and serviced only by personnel familiar with good safety practice and the handling of high-voltage electrical equipment. Failure to comply could result in death, severe personal injury and equipment damage.

---

**⚠ WARNING**

**Optional Capacitive Test Point Operating Instructions:** Use only voltage indicating instruments specifically designed for test points. Use of conventional voltage sensing devices may provide false "No Voltage" indications.

The test point must be dry and free of contaminant's when checking for voltage. After indication is taken: clean, dry, and lubricate the test point cap with silicone grease and assemble to the test point.

The capacitive test point is not sufficiently accurate, nor is it intended for, actual voltage measurements or phasing operations.

A reading of no voltage from the test point should not be the only indication of a de-energized circuit obtained before touching the connector. Other procedures can include direct conductor voltage testing or grounding using a live-line tool.

Failure to comply could result in death, severe personal injury and equipment damage.

---

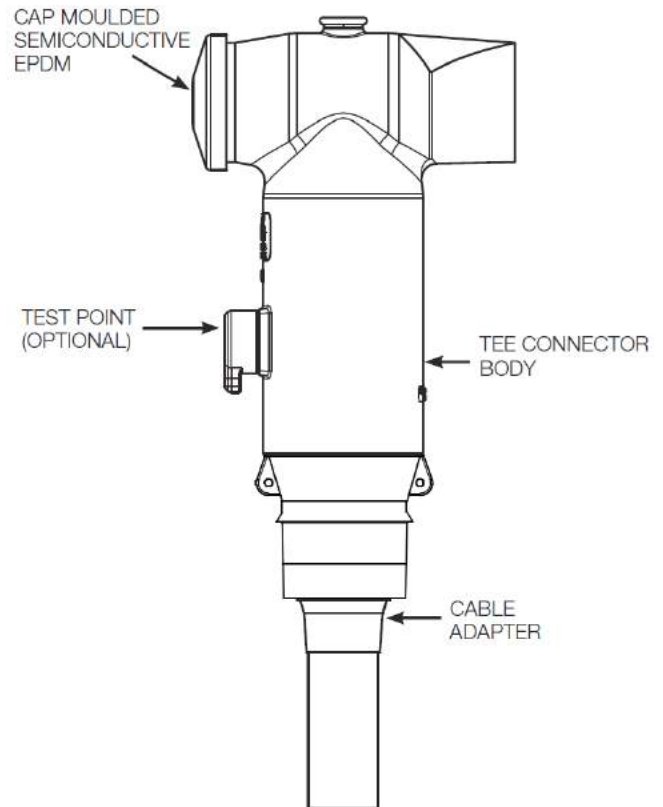

Figure 1. Line illustration of 42 kV bolted tee connector

## Product information

### Introduction

Eaton's Cooper Power series 1250 A, 42 kV bolted tee separable connectors are used to terminate polymeric cable to equipment, such as transformers, switchgear, motors etc. equipped with bushings meeting type C interface per CENELEC EN 50180 and 50181. They are fully screened and fully submersible when mated with the proper bushing or plug and they meet the requirements of CENELEC HD 629.1 S2. The bolted tee connectors can be mounted vertically, horizontally or any angle in between with proper cable support. Each bolted tee connector is tested for AC withstand and partial discharge prior to leaving the factory.

### Read this manual first

Read and understand the contents of this manual and follow all locally approved procedures and safety practices before installing or operating this equipment.

# DTS1242 Deadbreak Bolted Tee Connector: Interface C for Single Core Cable with Copper Wire Screen and Outer Sheath

## Additional information

These instructions cannot cover all details or variations in the equipment, procedures, or process described nor provide directions for meeting every possible contingency during installation, operation, or maintenance. For additional information, contact your representative.

## Acceptance and initial inspection

Each bolted tee connector is completely inspected and tested at the factory. It is in good condition when accepted by the carrier for shipment. Upon receipt of a bolted tee connector, inspect it thoroughly for damage and loss of parts incurred during shipment. If damage or loss is discovered, file a claim with the carrier immediately.

## Handling and storage

Be careful during handling and storage of the bolted tee connector to minimize the possibility of damage. If the bolted tee connector is to be stored for any length of time prior to installation, provide a clean, dry storage area.

## Standards

ISO 9001 Certified Quality Management System

## Installation procedure

### Kit contents

- 1 - Tee connector (test point optional)
- 1 - Cable adapter
- 1 - Crimp lug or mechanical lug
- 1 - Stud
- 1 - Nut
- 1 - Plug
- 1 - Rubber cap
- 1 - Cable sealing kit (if ordered)

Silicone lubricant, paper wipes, Iso (Isopropyl Alcohol) wipes and installation instructions.

### Tools required

- 13-mm open-end wrench
- 22-mm socket
- Torque wrench up to 70 Nm
- For mechanical lug (if ordered):
  - 6-mm Allen hex key for 400 mm<sup>2</sup> size
  - 8-mm Allen hex key for all other sizes

## CAUTION

**Optional Capacitive Test Point Operating Instructions:** Use only voltage indicating instruments specifically designed for test points. Use of conventional voltage sensing devices may provide false "No Voltage" indications.

**The test point must be dry and free of contaminants when checking for voltage. After indication is taken: clean, dry, and lubricate the test point cap with silicone grease and assemble to the test point.**

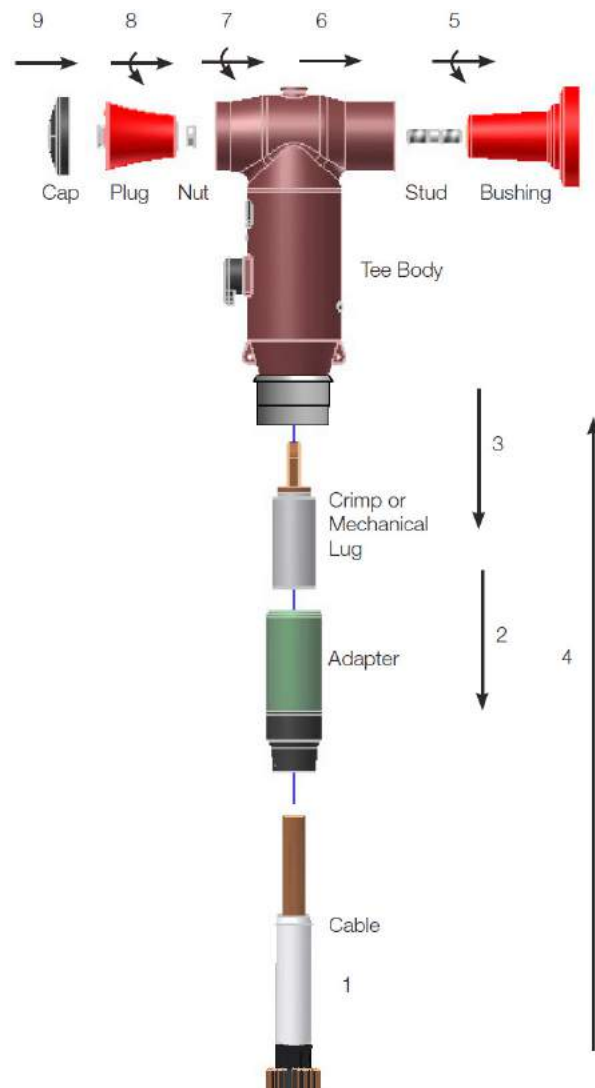
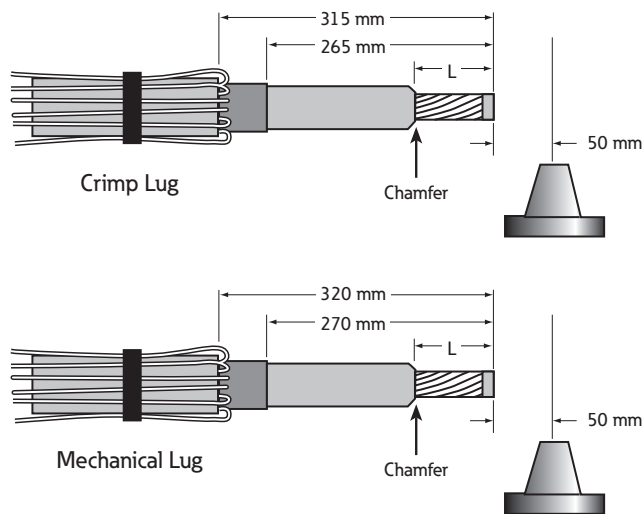

**Figure 2. Tee connector components (sequential order of installation shown)**

### Cable preparation (1)

1. Train the cable to the desired finished position and cut the cable. (See Figure 3.)

**Note:** If the cable is visibly bent, straighten it before installing the tee. A bent cable will result in a loose interface and reduce the dielectric withstand of the interface, especially for large cable sizes. Recommended method for straightening the cable: Heat up the cable to 90 °C by using a heat tape. Keep the tape on for approximately 120 minutes and then remove the heat tape. Keep the cable straight while cooling. It may be helpful to tape a splint to the cable while it is cooling down.



**Figure 3. Cable preparation for crimp lug (top) and mechanical lug (bottom)**

2. Remove the cable jacket for a distance of 315 mm (for crimp lug only) or 320 mm (for mechanical lug only) from the end of the cable.
3. Pull back drain wires. Use vinyl tape to secure wires temporarily.
4. Remove 265 mm (for crimp lug only) or 270 mm (for mechanical lug only) of insulation screen. Chamfer the sharp end at a 45° angle.
5. Remove “L” mm of cable insulation.

**Note:** Determine the value of “L” from Table 1.

6. Apply three layers of vinyl tape of the end of the conductor.

7. Remove vinyl tape from the screen wires. Wrap two half-lapped layers of sealing tape over cable sheath, then pull down the screen wires. Wrap two layers of sealing tape over screen wires, and cover the end of cable sheath and screen wires.

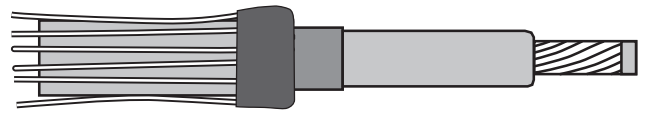

**Figure 4. Application of tape to conductor and screen wires**

**Table 1. Dimension “L”**

Conductor Size (mm <sup>2</sup> )	Crimp Lug	Mechanical Lug	
	L (mm)	L (mm)	Centering Sleeve Required
95	50	54	Yes
120			No
150			No
185	77	72	No
240			
300			
400		87	No
500	105	116	No
630	115		
800	-	123	No

### Adapter (2)

1. Polish and thoroughly clean the cable insulation, using sand paper provided if necessary, and Iso wipes.
2. Wrap two turns of vinyl tape to serve as marker at a position of 23 mm from end of insulation screen (see Figure 5).

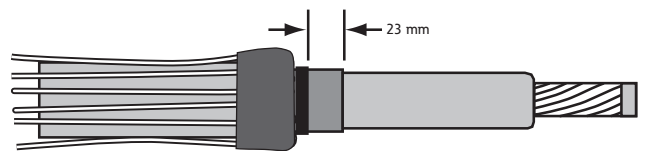

**Figure 5. Application of tape marker for cable adapter**

3. Lubricate exposed cable insulation and adapter inside interface.
4. Slide the cable adapter onto the cable, black end first, until the black end is flush with tape marker. Check the Critical Dimension as shown in Figure 6. Then remove the marker.

# DTS1242 Deadbreak Bolted Tee Connector: Interface C for Single Core Cable with Copper Wire Screen and Outer Sheath

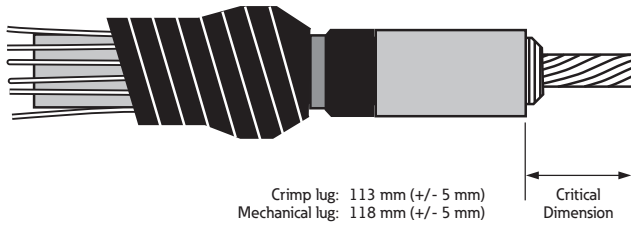

**Figure 6. Cable adapter: Critical Dimension for crimp lug and mechanical lug**

5. Wipe off grease from end of cable adapter preparing surface for application of tape.
6. Apply 3-4 layers of semi-conductive tape over the adapter edge and cable screen wires. Then apply 2 layers of sealing tape over the semi-conductive tape and caulk screen wires. Wrap 2-3 half-lapped layers of vinyl tape over the sealing tape.
7. Remove the tape from the end of the conductor.

## Crimp lugs (3)



**Figure 7. Crimp lug crimp sequence**

1. Wire brush conductor (aluminum only). Wipe off aluminum dust. Do not get dust on cable adapter.
2. Immediately insert the conductor into the crimping barrel as far as it will go. Ensure that the flat of the lug spade is parallel to the face of the bushing.
3. Crimp the lug starting at the mark on the barrel of the spade end of the lug as shown in Figure 7. Rotate the crimping tool 90 degrees for each successive crimp.
4. Remove any excess inhibitor that may have come out of the crimp lug. File off any sharp projections. Apply a layer of vinyl tape on the barrel.

**Table 2. Crimp and Mechanical Lug Chart**

Conductor Size (mm <sup>2</sup> )	Part Number (DIN Type)	Die Size	Part Number (Mechanical)	Allen Hex Key
95	CDT630U95	22	CDT630SB150	8 mm
120	CDT630U120	22		
150	CDT630U150	25		
185	CDT630U185	28	CDT630SB300	6 mm
240	CDT630U240	32		
300	CDT630U300	34		
400	CDT630U400	38	CDT630SB400	8 mm
500	CDT1250U500	44	CDT1250SB630	8 mm
630	CDT1250U630	48		
800	-	-	CDT1250SB800	

## Mechanical lugs (3)

1. Check Table 1 to see if a centering sleeve is required. If required, check the chart supplied with the lug to determine the correct color sleeve for the conductor size being used.
2. Wire brush conductor (aluminum only).
3. Immediately insert the conductor into the barrel of the lug and visually check that the lug is on as far as possible.
4. With the appropriate Allen hex key (per Table 2), screw in bolt No. 1 until it breaks off smoothly. Proceed with bolt No. 2 in a similar way. If the lug has more than two (2) bolts, continue with No. 3 (See Figure 8 for tightening sequence).
5. Once all the bolts have broken off, smooth any rough edges with a file and install the covering caps. Carefully clean off any filings.

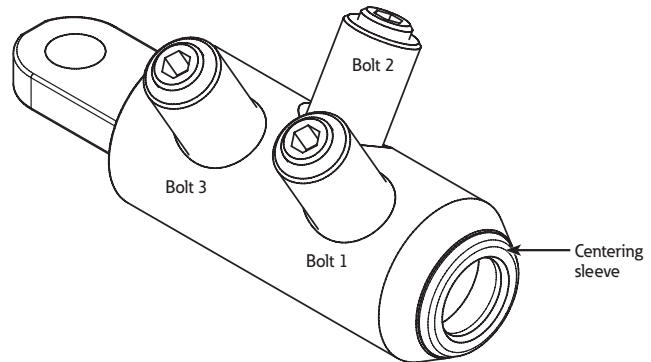

**Figure 8. Mechanical lug tightening sequence**



#### Tee body (4)

1. Clean the outer surface of the cable adapter and the interior of the cable entrance of the tee connector with a lint-free cloth. Apply a thin layer of lubricant to both surfaces.
2. Push the tee connector body over the cable adapter as far as it will go. Ensure that the hole in the top of the crimp connector is visible through the interface end of the tee.

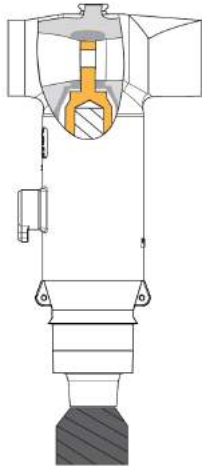

Figure 9. Tee connector body installation

#### Stud (5)

1. Tighten the stud to 55 Nm, using a 13-mm open-end wrench.

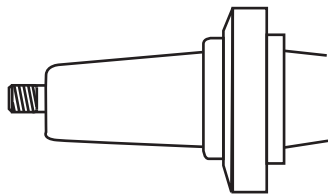

Figure 10. Installation of stud in bushing

#### Tee (6)

1. Clean the bushing interface and the tee connector interface with an Iso wipe. Wait for cleaning solvent to evaporate. Lubricate both interfaces.
2. Push the tee connector onto the bushing. Make sure the stud passes through the hole in spade of lug.

**Note: If a companion tee is to be installed, do not proceed any further. Follow the DTB1242 Deadbreak Bolted Companion Tee Connector Installation Instructions MN650024EN.**

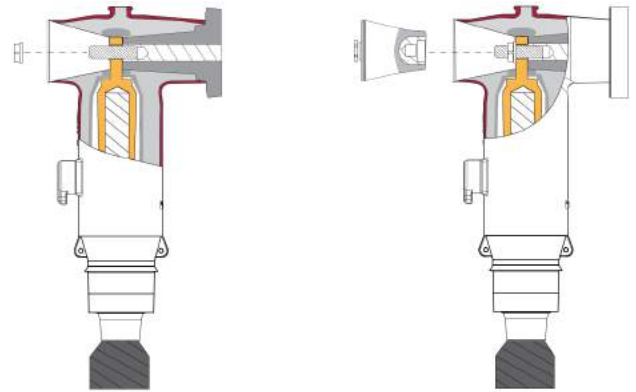

Figure 11. Installation of nut and deadend plug

#### Nut (7)

1. Put hex nut on the stud; then tighten the nut to 70 Nm using a torque wrench and a 22-mm socket.

#### Plug (8)

1. Clean the deadend plug and the tee connector interfaces with cleaning wipes. Wait for cleaning solvent to evaporate. Apply a thin layer of lubricant to both surfaces.
2. Insert the deadend plug into the tee and engage the threads of the threaded stud.
3. Tighten the deadend plug to 55 Nm using a torque wrench and 22-mm socket.

#### Cap and earth wire (9)

1. Clean the interior surface of the rubber cap.
2. Place it over the deadend plug and push it until it snaps into place.
3. If not already attached, connect drain wire to the grounding tab of tee body as shown in Figure 12.
4. Connect drain wire on tee body to earthing system.
5. Clamp the cable below cable jacket seal.

DTS1242 Deadbreak Bolted Tee Connector: Interface C for Single Core Cable with Copper Wire Screen and Outer Sheath

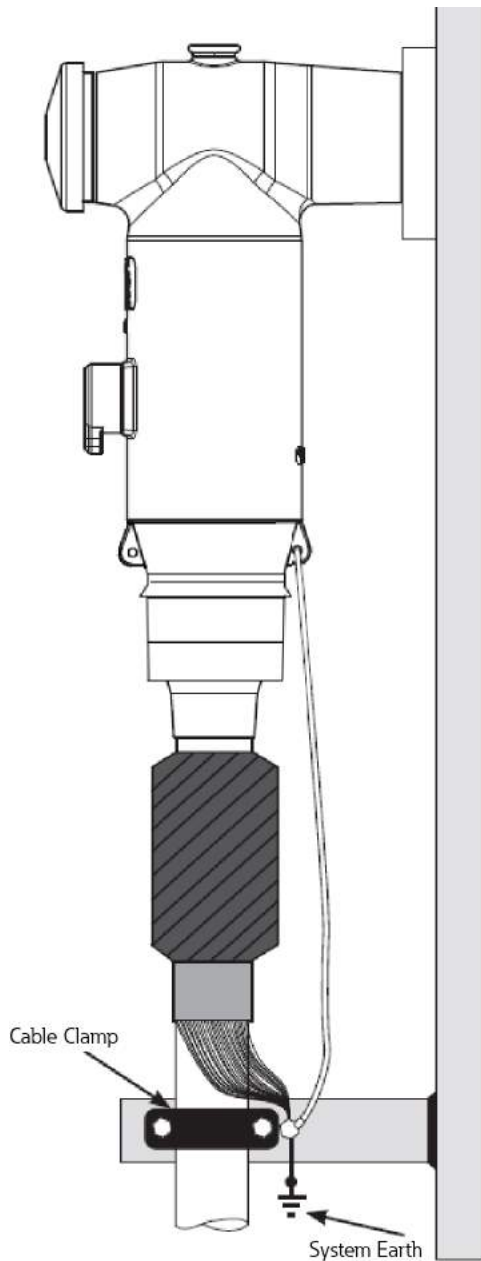

**⚠ CAUTION**

Clamp the cable as close as possible to the connector so that the connector/bushing mated combination does not carry the full weight of the cable.

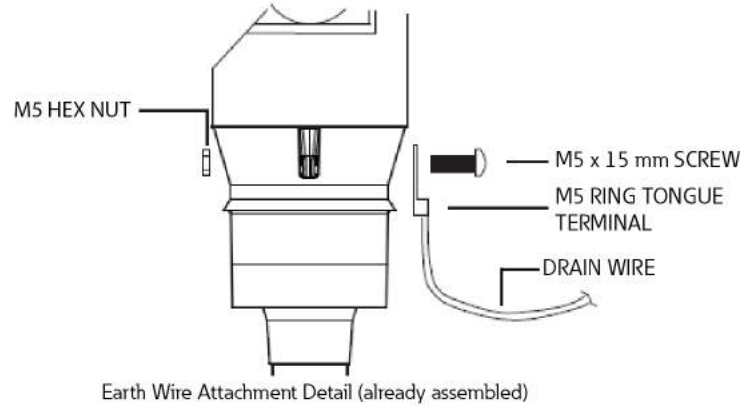

Figure 12. Cable clamp and screen wire earthing arrangement

This page is intentionally left blank.



**Eaton**  
1000 Eaton Boulevard  
Cleveland, OH 44122  
United States  
Eaton.com

**Eaton's Power Systems Division**  
2300 Badger Drive  
Waukesha, WI 53188  
United States  
Eaton.com/cooperpowerseries

© 2016 Eaton  
All Rights Reserved  
Printed in USA  
Publication No. MN650023EN Rev 00  
October 2016

Eaton is a registered trademark.

All trademarks are property  
of their respective owners.

For Eaton's Cooper Power series product  
information  
call 1-877-277-4636 or visit:  
[www.eaton.com/cooperpowerseries](http://www.eaton.com/cooperpowerseries).