



## **DISCLAIMER OF WARRANTIES AND LIMITATION OF LIABILITY**

The information, recommendations, descriptions and safety notations in this document are based on Eaton Corporation's ("Eaton") experience and judgment and may not cover all contingencies. If further information is required, an Eaton sales office should be consulted. Sale of the product shown in this literature is subject to the terms and conditions outlined in appropriate Eaton selling policies or other contractual agreement between Eaton and the purchaser.

THERE ARE NO UNDERSTANDINGS, AGREEMENTS, WARRANTIES, EXPRESSED OR IMPLIED, INCLUDING WARRANTIES OF FITNESS FOR A PARTICULAR PURPOSE OR MERCHANTABILITY, OTHER THAN THOSE SPECIFICALLY SET OUT IN ANY EXISTING CONTRACT BETWEEN THE PARTIES. ANY SUCH CONTRACT STATES THE ENTIRE OBLIGATION OF EATON. THE CONTENTS OF THIS DOCUMENT SHALL NOT BECOME PART OF OR MODIFY ANY CONTRACT BETWEEN THE PARTIES.

In no event will Eaton be responsible to the purchaser or user in contract, in tort (including negligence), strict liability or otherwise for any special, indirect, incidental or consequential damage or loss whatsoever, including but not limited to damage or loss of use of equipment, plant or power system, cost of capital, loss of power, additional expenses in the use of existing power facilities, or claims against the purchaser or user by its customers resulting from the use of the information, recommendations and descriptions contained herein. The information contained in this manual is subject to change without notice.

# Contents

## SAFETY INFORMATION

Safety Information .....	iv
--------------------------	----

## PRODUCT INFORMATION

Introduction .....	1
Acceptance and Initial Inspection .....	1
Handling and Storage .....	1
Standards .....	1

## INSTALLATION PROCEDURE

Installation Instructions .....	2
---------------------------------	---



## Safety for life



Eaton's Cooper Power Systems products meet or exceed all applicable industry standards relating to product safety. We actively promote safe practices in the use and maintenance of our products through our service literature, instructional training programs, and the continuous efforts of all Eaton's Cooper Power Systems employees involved in product design, manufacture, marketing, and service.

We strongly urge that you always follow all locally approved safety procedures and safety instructions when working around high voltage lines and equipment, and support our "Safety For Life" mission.

### Safety information

The instructions in this manual are not intended as a substitute for proper training or adequate experience in the safe operation of the equipment described. Only competent technicians who are familiar with this equipment should install, operate, and service it.

A competent technician has these qualifications:

- Is thoroughly familiar with these instructions.
- Is trained in industry-accepted high and low-voltage safe operating practices and procedures.
- Is trained and authorized to energize, de-energize, clear, and ground power distribution equipment.
- Is trained in the care and use of protective equipment such as arc flash clothing, safety glasses, face shield, hard hat, rubber gloves, clampstick, hotstick, etc.

Following is important safety information. For safe installation and operation of this equipment, be sure to read and understand all cautions and warnings.

#### Hazard Statement Definitions

This manual may contain four types of hazard statements:

#### DANGER

Indicates an imminently hazardous situation which, if not avoided, will result in death or serious injury.

#### WARNING

Indicates a potentially hazardous situation which, if not avoided, could result in death or serious injury.

#### CAUTION

Indicates a potentially hazardous situation which, if not avoided, may result in minor or moderate injury.

**CAUTION:** Indicates a potentially hazardous situation which, if not avoided, may result in equipment damage only.

#### Safety instructions

Following are general caution and warning statements that apply to this equipment. Additional statements, related to specific tasks and procedures, are located throughout the manual.

#### DANGER

**Hazardous voltage. Contact with hazardous voltage will cause death or severe personal injury. Follow all locally approved safety procedures when working around high- and low-voltage lines and equipment.** G103.3

#### WARNING

**Before installing, operating, maintaining, or testing this equipment, carefully read and understand the contents of this manual. Improper operation, handling or maintenance can result in death, severe personal injury, and equipment damage.** G101.0

#### WARNING

**This equipment is not intended to protect human life. Follow all locally approved procedures and safety practices when installing or operating this equipment. Failure to comply can result in death, severe personal injury and equipment damage.** G102.1

#### WARNING

**Power distribution and transmission equipment must be properly selected for the intended application. It must be installed and serviced by competent personnel who have been trained and understand proper safety procedures. These instructions are written for such personnel and are not a substitute for adequate training and experience in safety procedures. Failure to properly select, install or maintain power distribution and transmission equipment can result in death, severe personal injury, and equipment damage.** G122.3

## Product Information

### Introduction

DT400/436 Tee Connector Kit from Eaton's Cooper Power Systems is a premoulded separable connector designed for connection of polymeric (XLPE, EPR, etc.) cable to transformers, switchgear, motors and other electrical apparatus. It can be used indoors or outdoors in installations up to 36 kV requiring a continuous current rating of 630 A or less, where the mating bushing complies with CENELEC standard EN50180, Interface C.

### Read This Manual First

Read and understand the contents of this manual and follow all locally approved procedures and safety practices before installing or operating this equipment.

### Additional Information

These instructions cannot cover all details or variations in the equipment, procedures, or process described nor provide directions for meeting every possible contingency during installation, operation, or maintenance. For additional information, contact your representative.

### Acceptance and Initial Inspection

Each elbow is in good condition when accepted by the carrier for shipment. Upon receipt, inspect the shipping container for signs of damage. Unpack the elbow and inspect it thoroughly for damage incurred during shipment. If damage is discovered, file a claim with the carrier immediately.

### Handling and Storage

Be careful during handling and storage of the elbow to minimize the possibility of damage. If the elbow is to be stored for any length of time prior to installation, provide a clean, dry storage area.

### Standards

ISO 9001 Certified Quality Management System

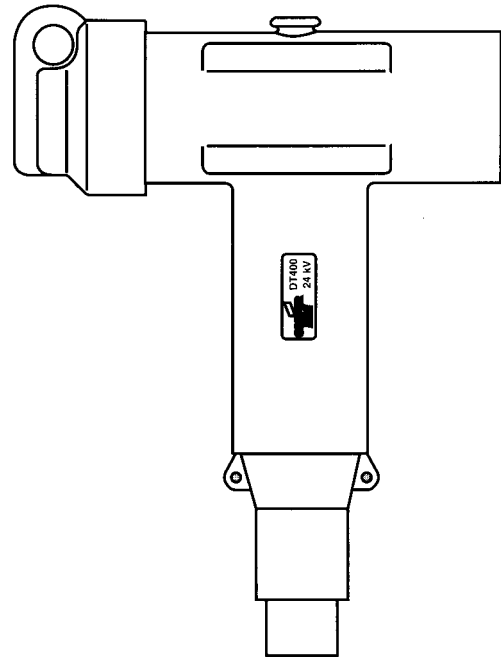

**Figure 1. 630 A deadbreak bolted tee connector.**

## Installation instructions

### Complete Tee Connector kit includes:

- 1 – Moulded tee connector
- 1 – Clamping screw
- 1 – Basic insulating plug
- 1 – Rubber cap
- 1 – Cable adapter
- 1 – Bi-metallic conductor contact
  - Silicone lubricant
  - Paper towel
  - Installation instructions

---

### WARNING

---

**Hazardous voltage. All associated apparatus must be de-energized during installation and/or maintenance. Failure to comply may result in death, severe personal injury and equipment damage.**

---

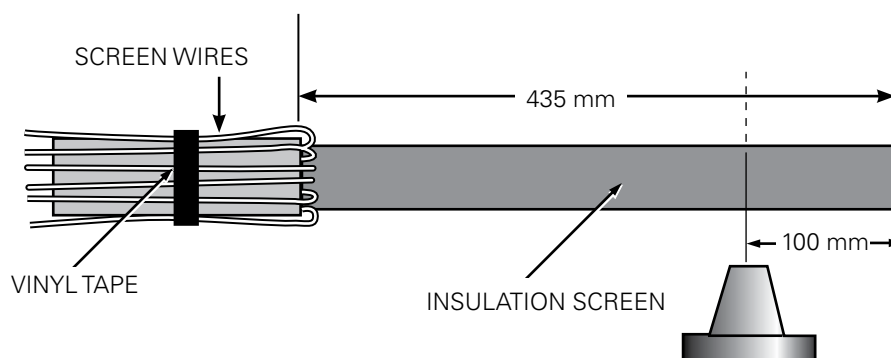

**Figure 2.**

### Step 1

1. Train the cable to the desired finished position. (See Figure 2.) Be sure that the cable is long enough to permit movement of the tee connector from the apparatus bushing to a standoff bushing.
2. Initially, cut the cable 100 mm past the bushing centerline.

**Note:** This is the initial length of the cable to ensure that the screen wires are long enough to reach the earthing eye on the tee connector. The cable will be cut to its final length in a later step.

3. Remove 435 mm of the cable sheath.
4. Fold the screen wires back over the sheath and secure them with two wraps of vinyl tape. (This step is optional. The vinyl tape is not included in the kit.)
5. Position the cable to its final position and cut it 50 mm from the centerline of the apparatus bushing. See Figure 3.

## Step 2

1. Remove 225 mm of the insulation screen.
2. Remove 77 mm of core insulation.
3. Cut a 45° chamfer onto the end of the cable insulation.

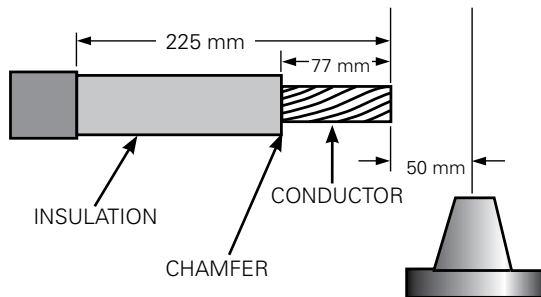

**Figure 3. Removal of insulation.**

## Step 3

1. Thoroughly clean the core insulation, using a suitable cleaner and a lint-free cloth.
2. Wrap several layers of electrical tape over the end of the conductor.
3. Apply a thin layer of lubricant to the core insulation and the inside diameter of the cable adapter.
4. Slide the cable adapter onto the cable, black end first, until the grey end is 85 mm from the end of the cable. Remove the electrical tape from the conductor.

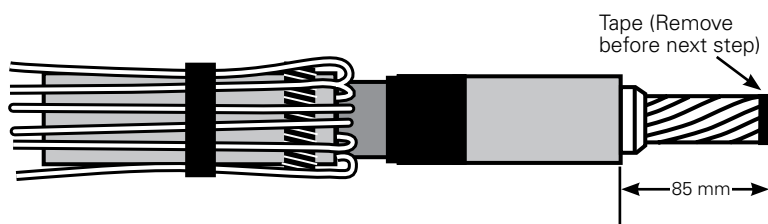

**Figure 4. Cable adapter insulation.**

## Step 4

1. If the conductor is aluminum, thoroughly wire brush the exposed conductor.
2. Immediately insert the conductor into the crimp barrel as far as it will go. Ensure that the flat of the copper face is parallel to the face of the bushing.
3. Crimp the connector starting at the shoulder, as shown. Rotate the crimping tool 90° for each successive crimp.
4. Remove any inhibitor that may come out of the crimp connector.

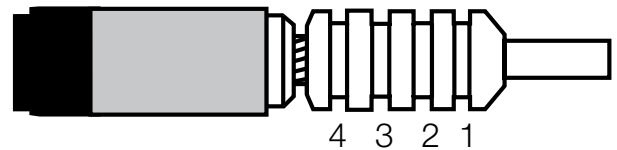

**Figure 5. Insertion of conductor into crimp barrel.**

## Step 5

1. Clean the outer surface of the cable adapter and the interior of the cable end of the tee connector with a lint-free cloth. Apply a thin layer of lubricant to both surfaces.
2. Push the tee connector over the cable adapter as far as it will go. Ensure that the hole in the top of the crimp connector is visible through the interface end of the tee.
3. Connect one of the screen wires to an earthing eye on the tee connector.

### Step 6

1. Clean the bushing interface and the tee interface and apply a thin layer of lubricant to each.
2. Push the tee connector onto the bushing.

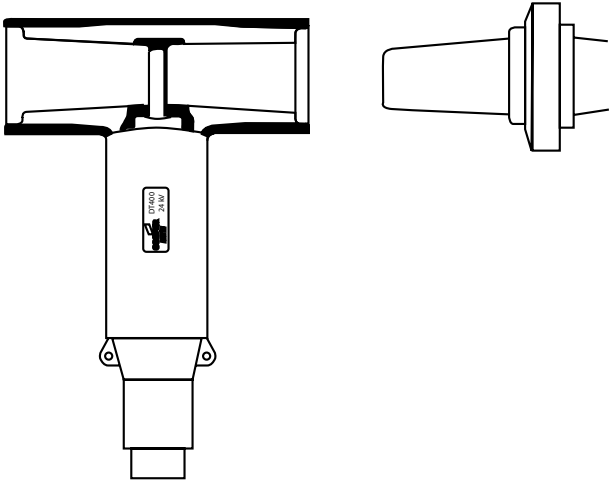

Figure 6. Installation of tee connector onto bushing.

### Step 7

1. Insert the long threaded end of the clamping screw through the hole of the crimp connector and into the threaded hole of the bushing, taking care to avoid cross-threading.
2. Tighten the clamping screw to a torque of 50 Nm (37 ft-lbs) using a 22 mm socket wrench.

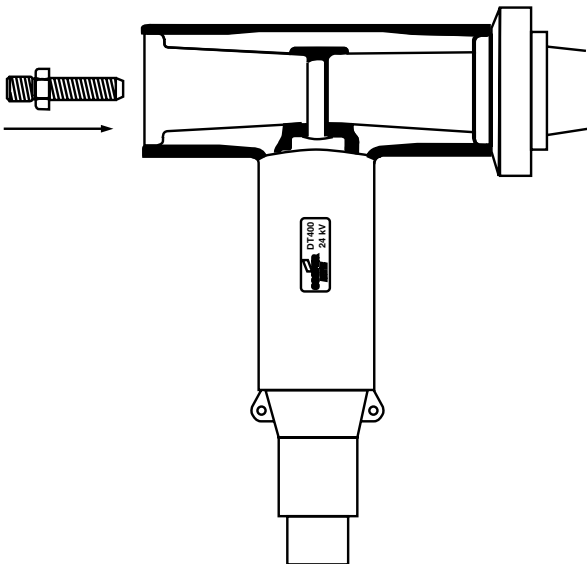

Figure 7. Installation of clamping screw.

### Step 8

1. Clean and apply lubricant to the insulating plug and the tee connector interface.
2. Insert the insulating plug into the connector and engage the threads of the clamping screw.
3. Tighten the insulating plug to a torque of 40 Nm (30 ft-lbs), using a torque wrench and 24 mm socket wrench.

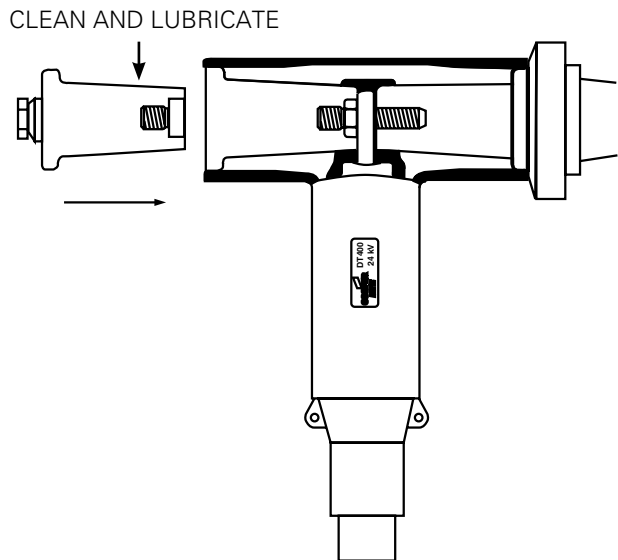

Figure 8. Installation of insulating plug.



### Step 9

1. Clean the interior surface of the rubber cap.
2. Place it over the insulating plug and push it until it snaps into place.

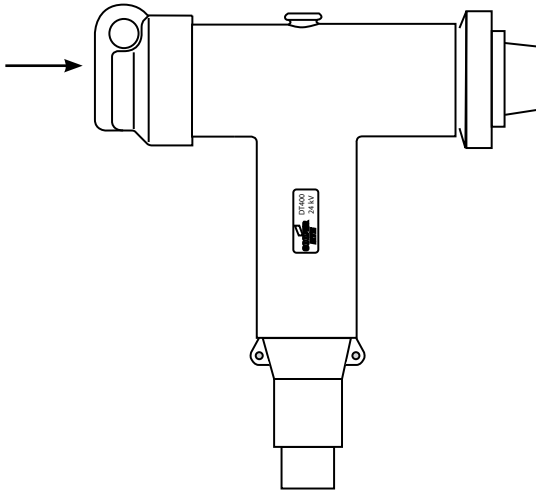

Figure 9. Installation of cap.

---

### CAUTION

---

The apparatus bushing and tee connector should not support the weight of the cable. Clamp the cable immediately below the cable screen adapter. Failure to comply may result in equipment damage.

---

This page is intentionally left blank.

This page is intentionally left blank.



**Eaton**  
1000 Eaton Boulevard  
Cleveland, OH 44122  
United States  
Eaton.com

**Eaton's Cooper Power Systems  
Business**  
2300 Badger Drive  
Waukesha, WI 53188  
cooperpower.com

© 2014 Eaton  
All Rights Reserved  
Printed in USA  
Publication No. MN650001EN / Rev 00

Eaton and Cooper Power Systems are valuable trademarks of Eaton, in the U.S. and other countries. You are not permitted to use these trademarks without the prior written consent of Eaton.