

Current-limiting fuse mounts



General

Eaton provides overload protection for all indoor and underground cable distribution systems with its Cooper Power™ series current-limiting fuse mountings. They are available in single-unit clip or hinge-style, parallel-unit clip-style, channel based tandem, and single-phase or three-phase feed-through hinge-style mountings. Indoor and underground mountings and Eaton's fusing characteristics make possible a wide variety of sectionalizing, switching, and protective schemes, with compactness and safety unattainable with other fusing equipment. For additional mounting arrangements contact your Eaton representative.

Clip-style mounting

Eaton's Cooper Power series basic NX®, ELX, and X-Limiter™ fuses are all designed to mount in an Eaton clip-style mounting, where there is no switching or loadbreaking required. The clip-style mount is available in a single or parallel unit mount to accommodate your fusing system design (shown upper left). Refer to catalog section CA132049EN for more detailed information on NX fuses, catalog section CA132053EN for ELX fuses and catalog section CA132050EN for X-Limiter fuses.

Hinge-style mounting

The NX hinge-style fuses with an Arc-Strangler® loadbreaking device or NX Arc-Strangler switchblade fit in a hinge-style mounting (shown upper right). Refer to catalog section CA132049EN for more detailed information on the NX hinge-style fuse with an Arc-Strangler loadbreaking device or Arc-Strangler switchblade.

Single- and three-phase frame mounting

These mountings have the same hinge and clip contact assemblies and terminal pads as described in the section on open channel-based mountings.

The frame mountings consist of a flat backing plate, Benelex® insulating barriers, and porcelain support insulators with hinge and clip contact assemblies. Both single and three-phase styles are available.

Fuses and switchblades can be inserted, opened, and removed easily and safely in either the frame mountings with a standard hookstick or Eaton's Cooper Power series universal switchstick head. (See Figure 6 for drawing and dimensions.)

EATON

Powering Business Worldwide

Channel-based tandem mounting

Channel-based tandem mountings are available in several styles to accommodate a variety of switching and fusing system designs. For applications requiring no switching or loadbreaking capability, the basic clip-style mounting is available for either single or parallel fuses. A mounting with a hinge at the bottom to provide the switching or loadbreaking capability required is available for NX fuse with Arc-Strangler loadbreaking, and NX Arc-Strangler switchblades. A tandem unit that holds an Arc-Strangler switch and a clip-mounted fuse is also available in various ratings.

Clip- and hinge-style mounting features

- Silver-plated copper contacts with stainless steel backup springs ensure cool operation
- Detent on the clip contacts holds the fuse firmly closed
- A rugged, close-in guide prevents deformation of the mounting contacts when the fuse is closed or opened and prevents closing if the operator forgets to recock the Arc-Strangler sleeve
- The pinned bolt securely fastens the contact to insulator support and prevents the contacts from rotating
- A tin-plated copper terminal pad on single-unit mountings is furnished with a 3/8-inch bronze bolt to accommodate spade terminals
- A copper or tin-plated terminal pad on parallel mountings accommodates NEMA® standard two-bolt connectors or accessory clamp-type connectors.
- Hinge-style mountings can be ordered for either a 110° or a 180° opening. (A 110° opening is recommended for mountings to be installed at shoulder height or lower.)
- The channel base is strong and easy to install. Mounting holes and slots accommodate 1/2-inch bolts. The base conforms to the vertical mounting centers for rails in Transclosure® housings and other enclosures. Galvanized, formed steel hinges firmly support the fuse and permit the easy removal of the fuse from the mounting with either a standard hookstick or with a universal switchstick head (see Figure 6).
- A rubber bumper prevents pulling breakage caused by excessive close-in pressure with a switchstick

Application

All channel-based and most frame mountings for hinged fuses or switchblades are available with one of two hinge constructions: One allows 110° swingdown on the opening; the other, a 180° swingdown. Exact swingdown dimensions can be determined from dimensional information section. Operator position, as well as clearances, are essential when considering which hinge style is suitable.

Units providing a 110° opening are recommended for most installations. Mountings that allow fuses or switchblades to swing down 180° are recommended where the hinge level will be above the shoulder height of the operator. This enables easy removal of an opened switch or fuse with a standard-head hook-stick. The use of mountings with 180° hinges below this height prevents the removal of a fuse or a switchblade with a hookstick.

All channel-based and frame mountings for hinge-style fuses and switchblades are available in two hinge-to-upper-contact spacings. Mountings with the longer spacing (Code No. 2), available with BIL ratings of 95 or 125 kV, accommodates 15.5 kV fuses and the long 15.5 kV switchblades. Mountings with the shorter spacing (Code No. 1), rated 95 kV BIL, accommodate 4.3, 5.5, or 8.3 kV fuses and 8.3 kV or short 15.5 kV switchblades.

For normal 15 kV switch application the short 15.5 kV switchblade in a mounting with the shorter hinge-to-upper-contact spacing is recommended. Long 15.5 kV switchblades in mountings with the longer spacing can be used when interchangeability with 15.5 kV fuses is desired. Mountings for clip-style fuses are available in five clip-to-clip spacings.

Table 1 shows the code numbers for fuses and switchblades to simplify ordering and application, assuring the correct fuses or switchblades to fit the mounting selected. These codes are governed by two factors – style of mounting and size.

Table 1. Coding System – Mounting for Fuses and Arc-Stranglers

Rating Group	Features	Mounting Code
Hinge-Mounting		
8.3 kV and Below (Shorter Spacing)	110° or 180° Opening	1
15.5 kV (Longer Spacing)	110° or 180° Opening	2
Clip-Mounting		
All 4.3 and 5.5 kV NX	–	4
8.3 NX (1.5 - 40 A)	–	4
All 4.3 and 5.5 kv X-Limiter	–	4
8.3 kV X-Limiter (3-40 A and 50 A DW)	–	4
All 8.23 kV ELX	–	4
8.3 kV NX (50-100 A)	–	5
15.5 kV NX (1.5-40 A)	–	5
8.3 kV X-Limiter (50-140 A)	–	5
15.5 kV X-Limiter (3-40 A and 50 A DW)	–	5
All 15.5 kV ELX	–	5
15.5 kV NX (50-100 A)	–	6
All 23 kV NX	–	6
15.5 kV X-Limiter (50-125 A)	–	6
23 kV X-Limiter (3-40 A and 50 A DW)	–	6
All 23 kV ELX	–	6
23 kV X-Limiter (50-100 A)	–	9
Clip-Mounting (High-Voltage)		
27 kV NX (6-50 A)	–	9
38 kV NX (6-50 A)	–	10

Clip-Style Mountings

Table 2. Ratings and Dimensions of Channel-Based Mountings for Clip-Style Fuses (See Figures 1 and 2)

Maximum Voltage Rating (kV)	BIL (kV)	Mounting Code Number*	Catalog Number	Dimensions in. (mm)**								
				A	B	C	D	E	F	G	H	
Single Fuse, Single Pole												
8.3	95	4	FAB1D1	17.63 (448)	11.13 (283)	9.75 (248)	14.13 (359)	5.00 (127)	–	3.88 (99)	1.50 (38)	
15.5	95	5	FAB1D2	21.88 (556)	15.38 (391)	9.75 (248)	18.38 (467)	9.00 (229)	–	4.63 (117)	1.50 (38)	
15.5	125	5	FAB1D4	21.88 (556)	15.38 (391)	11.13 (283)	18.38 (467)	9.00 (229)	–	4.63 (117)	1.50 (38)	
15.5	95	6	FAB1D5	24.69 (627)	18.19 (462)	9.75 (248)	21.19 (538)	11.81 (300)	–	4.63 (117)	1.50 (38)	
15.5	95	6	FAB1D10	24.69 (627)	18.19 (462)	9.75 (248)	21.19 (538)	8.31 (211)	–	6.44 (164)	1.50 (38)	
15.5	125	6	FAB1D11	24.69 (627)	18.19 (462)	11.13 (283)	21.19 (538)	8.31 (211)	–	6.44 (164)	1.50 (38)	
15.5	125	6	FAB1D8	24.69 (627)	18.19 (462)	11.13 (283)	21.19 (538)	11.81 (300)	–	4.63 (117)	1.50 (38)	
23	125	6	FAB1D9	24.69 (627)	18.19 (462)	11.13 (283)	21.19 (538)	11.81 (300)	–	4.63 (117)	1.50 (38)	
23	150	6	FAB1D3	24.69 (627)	18.19 (462)	12.50 (318)	21.19 (538)	11.81 (300)	–	4.63 (117)	1.50 (38)	
27	150	9	FAB1D6	34.56 (878)	28.06 (713)	13.06 (332)	32.06 (814)	17.50 (445)	–	7.25 (184)	1.25 (32)	
38	150	10	FAB1D7	42.56 (1081)	36.06 (916)	13.06 (332)	40.06 (1018)	25.00 (635)	–	7.50 (191)	1.25 (32)	
Parallel Fuse, Single Pole												
8.3	95	4	FAB1K1	20.75 (527)	11.00 (279)	9.43 (240)	14.0 (356)	4.25 (108)	6.25 (159)	4.88 (124)	1.50 (38)	
15.5	95	5	FAB1K2	25.13 (638)	15.38 (391)	9.43 (240)	18.38 (467)	8.62 (219)	6.25 (159)	4.88 (124)	1.50 (38)	
15.5	125	5	FAB1K3	25.13 (638)	15.38 (391)	11.43 (290)	18.38 (467)	8.62 (219)	6.25 (159)	4.88 (124)	1.50 (38)	
15.5	95	6	FAB1K4	27.94 (710)	18.19 (462)	9.43 (240)	21.37 (543)	11.44 (291)	7.69 (195)	4.88 (124)	1.50 (38)	
23	125	6	FAB1K5	27.94 (710)	18.19 (462)	11.43 (290)	21.37 (543)	11.44 (291)	7.69 (195)	4.88 (124)	1.50 (38)	
23	150	6	FAB3K3	27.94 (710)	18.19 (462)	13.88 (353)	22.19 (564)	11.44 (291)	7.69 (195)	5.25 (133)	2.0 (51)	
27	150	9	FAB3K1	37.81 (960)	28.06 (713)	13.88 (353)	32.06 (814)	17.50 (445)	7.69 (195)	7.25 (184)	2.0 (51)	
38	150	10	FAB3K2	45.81 (1164)	38.06 (916)	13.88 (353)	40.06 (1018)	25.0 (635)	7.69 (195)	7.50 (191)	2.0 (51)	

* Code number of mounting must match code number of fuse.

** Refer to Figures 1 and 2 for dimensional drawings.

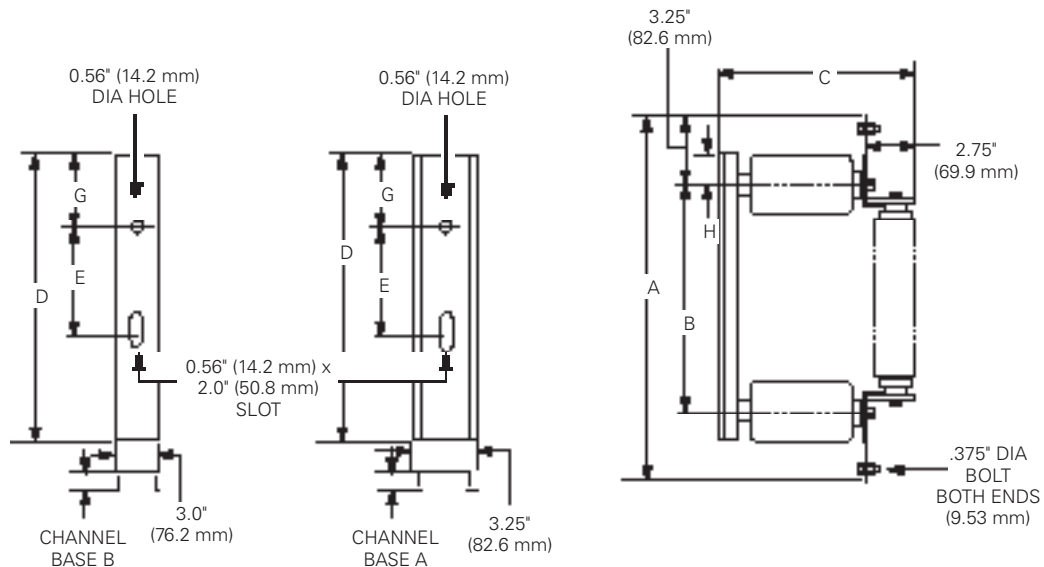

Figure 1. Single fuse, single-pole mounting (FAB1D series) for clip-mounted fuses (refer to Table 2 for dimensions).

Note: Channel B is used on FAB1D6 and FAB1D7; all other FAB1D series employ channel base A.

Clip-style mountings

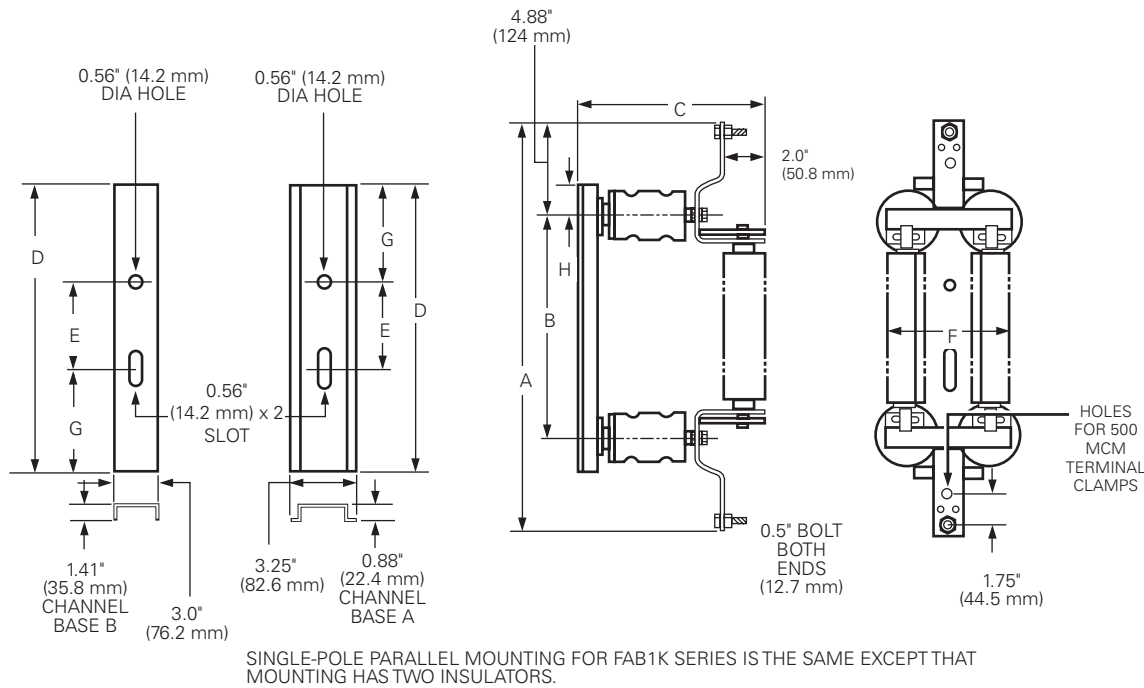

Figure 2. Parallel fuse, single-pole mounting for clip-mounted fuses FAB1K and FAB3K series (refer to Table 2 for dimensions) (FAB3K shown).

Hinge-style mountings

Table 3. Ratings and Dimensions of Channel-Based Mountings for Hinge-Style Fuses (with Arc-Strangler Loadbreaking Device or Arc-Strangler Switchblade)

Maximum Voltage (kV)	BIL (kV)	Mounting Code Number*	Catalog No.		Dimensions in. (mm)**					
			110° Open	180° Open	A	B	C	D	E	F
Single-Pole Mounting										
8.3	95	1	FA1D1	FAA1D1	18.25 (464)	11.13 (283)	14.0 (356)	5.0 (127)	9.75 (248)	8.69 (221)
15.5	95	2	FA1D2	FAA1D2	22.50 (572)	15.38 (391)	18.38 (467)	9.00 (229)	9.75 (248)	8.69 (221)
15.5	125	2	FA1D4	—	22.50 (572)	15.38 (391)	18.38 (467)	9.00 (229)	11.13 (283)	10.0 (256)
15.5	150	2	FA1D5	—	22.50 (572)	15.38 (391)	18.38 (467)	9.00 (229)	12.50 (318)	11.4 (291)
Parallel-Pole Mounting										
8.3	95	1	FA1K1	—	20.87 (530)	11.13 (283)	14.0 (356)	4.25 (108)	9.43 (240)	—
15.5	95	2	FA1K2	—	25.25 (641)	15.5 (394)	18.38 (467)	8.62 (219)	9.43 (240)	—
15.5	125	2	FA1K3	—	25.25 (641)	15.5 (394)	18.38 (467)	8.62 (219)	11.4 (290)	—

* Code number of mounting must match code number of fuse.

** See Figure 3 for dimensional drawing.

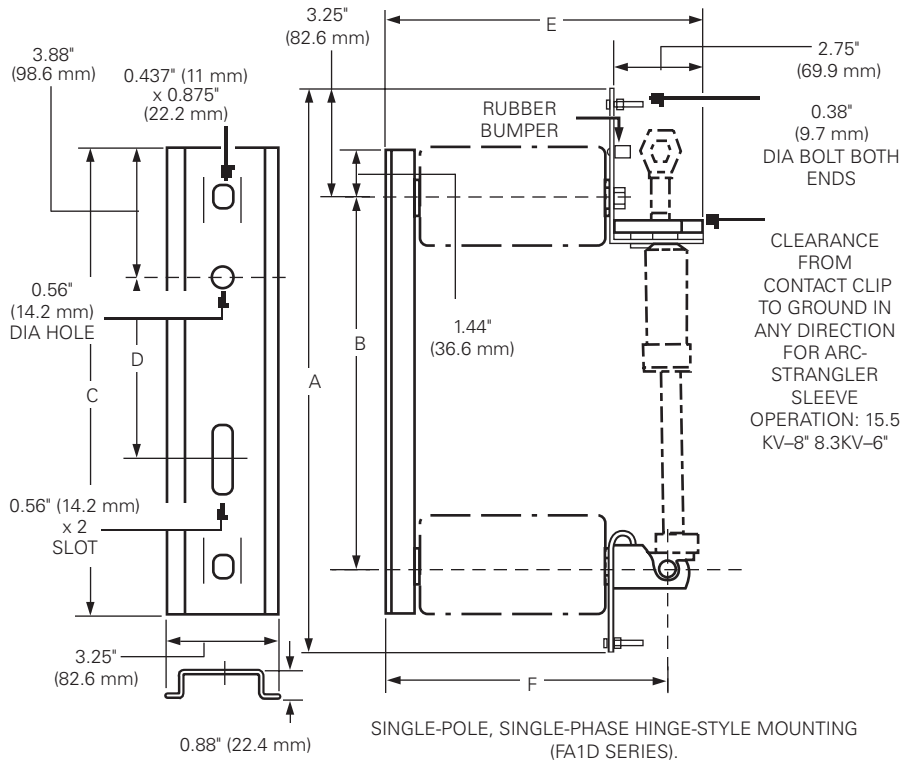

Figure 3. Single-pole, single-phase hinge-style mounting FA1D series (refer to Table 3 for dimensions).

Channel-based tandem mountings

Table 4. Ratings and Dimensions of Channel-Based Tandem Mountings (See Figures 8 and 9 for Dimensional Drawings)

Voltage Rating (kV)	BIL (kV)	Mounting Code Number*			Dimensions in. (mm)**			
		Switch	Fuse	Catalog Number	A	B	C	D
With Switchblade Mounted Above Fuse								
Single-Unit Mounting								
8.3	95	1	5	FAJ1D1	31.81 (808)	15.94 (405)	30.06 (764)	17.19 (437)
15.5	95	1	6	FAJ1D2	34.63 (880)	18.75 (476)	32.88 (835)	20.0 (508)
15.5	125	1	6	FAJ1D3	34.63 (880)	18.75 (476)	32.88 (835)	20.0 (508)
Parallel-Units Mounting								
15.5	95	1	4	FAJ1K3	29.31 (745)	11.0 (279)	27.56 (700)	12.75 (324)
8.3	95	1	5	FAJ1K1	33.63 (854)	15.31 (389)	31.88 (810)	17.06 (433)
15.5	95	1	6	FAJ1K2	36.44 (926)	18.13 (461)	34.69 (881)	19.88 (505)
With Fuse Mounted Above Switchblade								
Single-Unit Mounting								
8.3	95	1	5	FAJ3D1	36.49 (927)	17.88 (454)	33.38 (848)	17.5 (445)
15.5	95	1	6	FAJ3D2	39.30 (998)	20.69 (526)	36.19 (919)	20.0 (508)
Parallel-Units Mounting								
8.3	95	1	4	FAJ3K3	32.13 (816)	13.5 (343)	29.0 (737)	15.0 (381)
8.3	95	1	5	FAJ3K1	36.50 (927)	17.88 (454)	33.38 (848)	17.5 (445)
15.5	95	1	6	FAJ3K2	39.31 (999)	20.69 (526)	36.19 (919)	20.0 (508)

* Code number of mounting must match code number of fuse or switchblade.

** Refer to Figures 4 and 5 for dimensional drawing.

Channel-Based Tandem Mountings

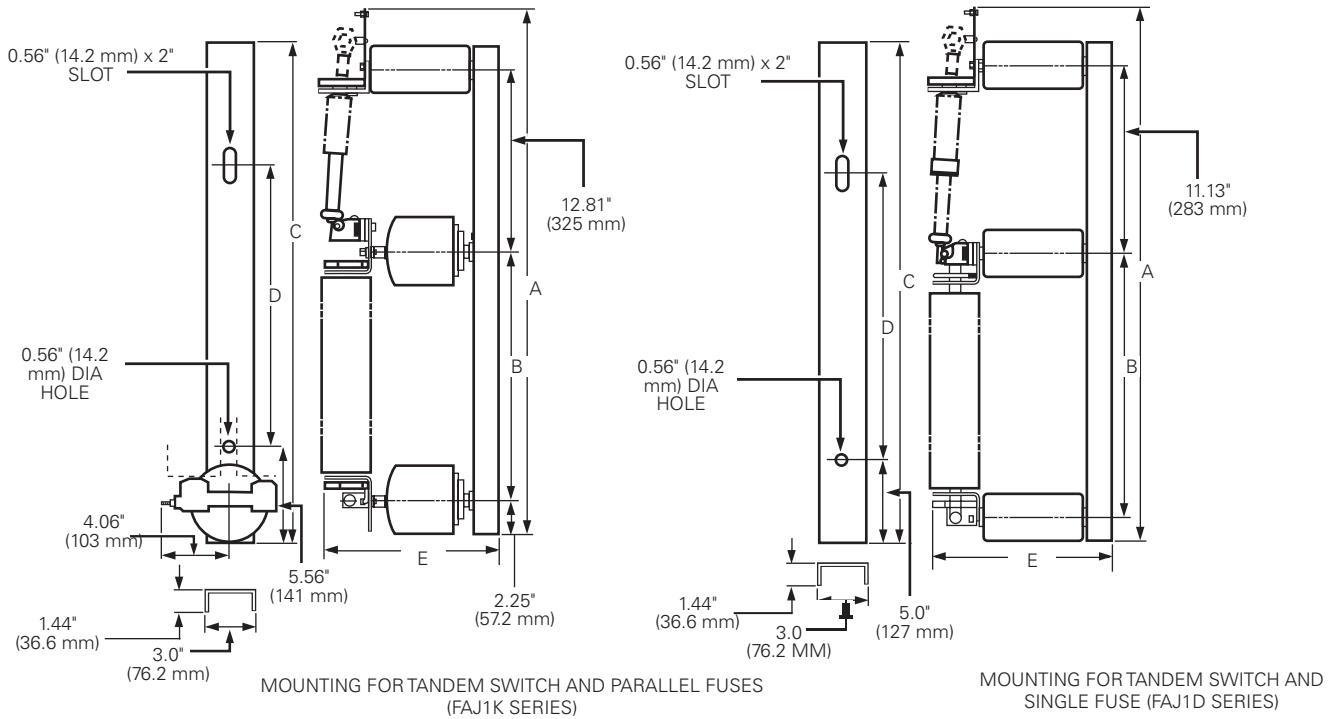

Figure 4. Tandem switch and single or parallel fuse mountings, FAJ1K and FAJ1D series (refer to Table 4 for dimensions).

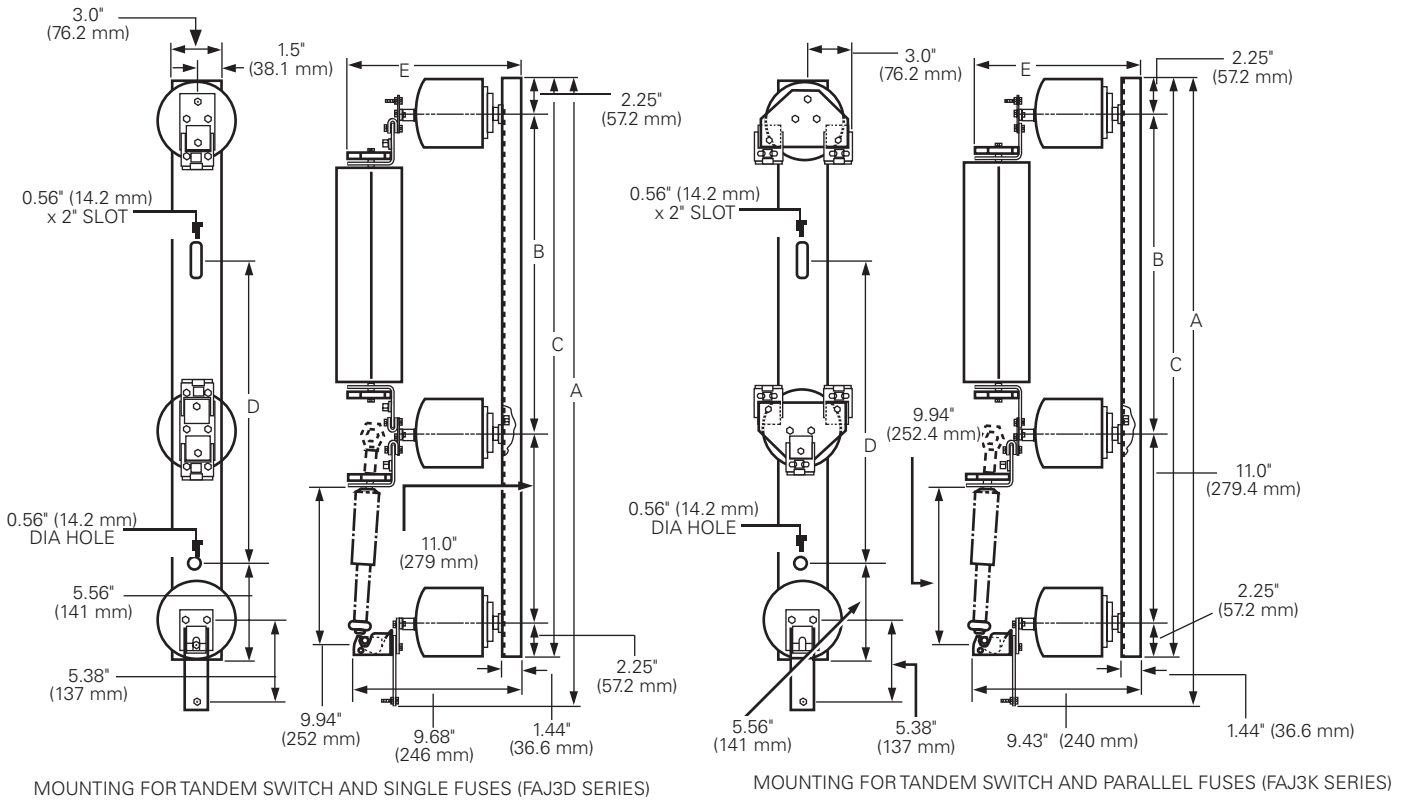

Figure 5. Tandem switch and single or parallel fuse mountings, FAJ3D and FAJ3K series (refer to Table 4 for dimensions).

Universal switchstick head

An accessory hook (refer to Figure 10 for drawing and dimensions) is available for universal switchsticks to provide easy installation and removal of a hinge-style fuse and switchblades.

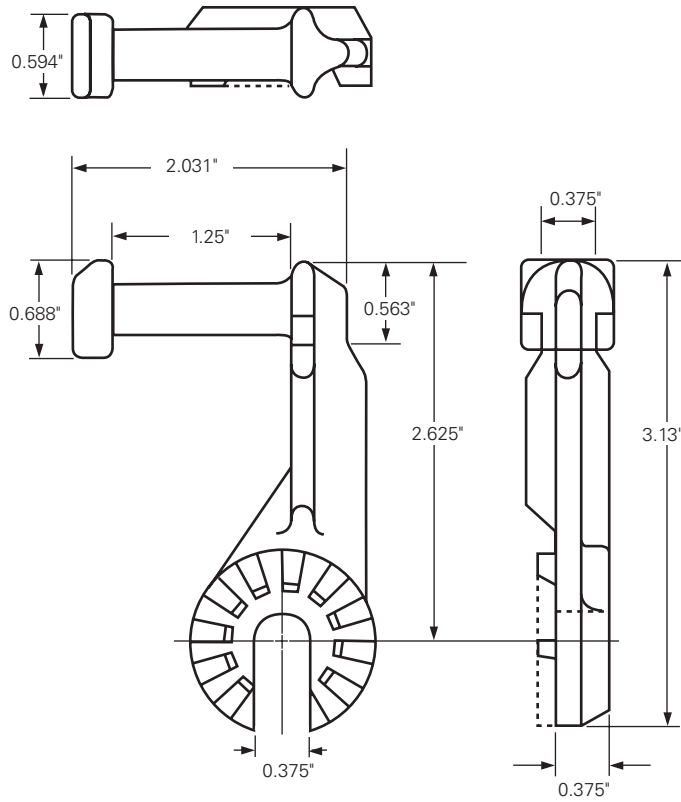

Figure 6. Universal switchstick head (FA13M1C).

Table 5. Ratings of Frame Mountings*

Maximum Design Voltage (kV)	BIL (kV)	Description	Mounting Code Number*	Catalog Number	
				110°† Opening	180°† Opening
8.3	95	Three-phase, frame mounting	1	FA1F1	–
15.5	95		2	FA1F2	–
15.5	125		2	FA1F3	–
8.3	95	Single-phase, feed-through, common-latch frame mounting with five insulators	1	FA1E1	FAA1E1
8.3	95		1	FA1F4	–
15.5	95		2	FA1E2	–
15.5	125		2	FA1E3	–
8.3 or 15.5	95	Single-phase, feed-through, common-latch	1	FA2E1	–
	125	frame mounting with four insulators††	1	FA2E2	–
15.5	125	Single-phase, feed-through, common-latch frame mounting with four insulators††	2	FA2E3	–
					–
8.3	95	Single-phase, feed-through, common-hinge frame mounting with three insulator (VI style)††	1	FA5E1	–

* Fuses or switchblades are not included in mountings and must be ordered separately.

** Code Number of mounting must match code number of fuse or switchblade.

† Refer to dimensional drawing for exact opening dimensions.

†† Uses transformer bushing as remaining insulator required for center fuse support.

Table 6. Dimensions of Frame Mountings (see Figures 11, 12, 13, and 14 for Dimensional Drawings)

Catalog Number	Dimensions in. (mm)*									
	A	B	C	D	E	F	G	H	I	J
FA1F1	13.75 (349)	3.5 (89)	3.63 (92)	13.31 (338)	11.13 (283)	24.0 (610)	8.94 (227)	7.8 (198)	12.0 (305)	5.13 (130)
FA1F2	18.13 (461)	8.5 (216)	3.31 (84)	17.81 (452)	15.5 (394)	28.0 (711)	8.94 (227)	7.8 (198)	12.0 (305)	5.13 (130)
FA1E1	13.75 (349)	3.5 (89)	3.63 (92)	13.31 (338)	11.13 (283)	12.0 (305)	8.94 (227)	7.8 (198)	12.0 (305)	4.44 (113)
FA1E4	13.75 (349)	3.5 (89)	3.63 (92)	13.31 (338)	11.13 (283)	18.0 (457)	8.94 (227)	7.8 (198)	12.0 (305)	4.44 (113)
FA1E2	18.13 (461)	8.5 (216)	3.31 (84)	17.81 (452)	15.5 (394)	12.0 (305)	8.94 (227)	7.8 (198)	12.0 (305)	4.44 (113)
FA1E3	18.13 (461)	8.5 (216)	3.31 (84)	17.81 (452)	15.5 (394)	14.0 (356)	10.31 (262)	9.2 (230)	14.0 (356)	6.44 (164)
FA2E1	13.75 (349)	3.5 (89)	3.63 (92)	13.31 (338)	11.13 (283)	12.0 (305)	8.94 (227)	7.8 (198)	4.44 (113)	–
FA2E2	13.75 (349)	3.5 (89)	3.63 (92)	13.31 (338)	11.13 (283)	14.0 (356)	10.31 (262)	9.0 (229)	6.44 (164)	–
FA2E3	18.13 (461)	8.5 (216)	3.31 (84)	17.81 (452)	15.5 (394)	14.0 (356)	10.31 (262)	9.0 (229)	6.44 (164)	–
FA5E1	See Figure 10 for dimensional drawing.									

* See Figures 7, 8, 9 and 10 for dimensional drawings.

Frame and box mountings

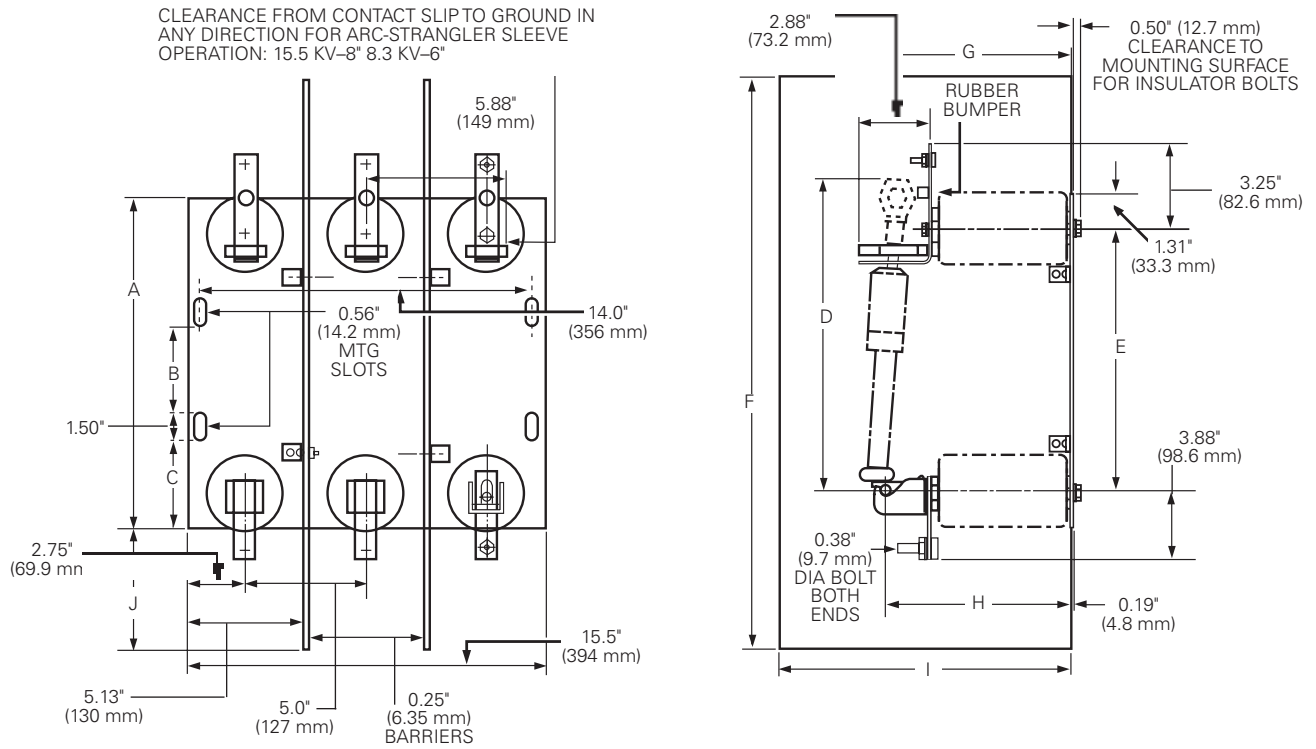

Figure 7. Three-phase frame mounting (FA1F Series).

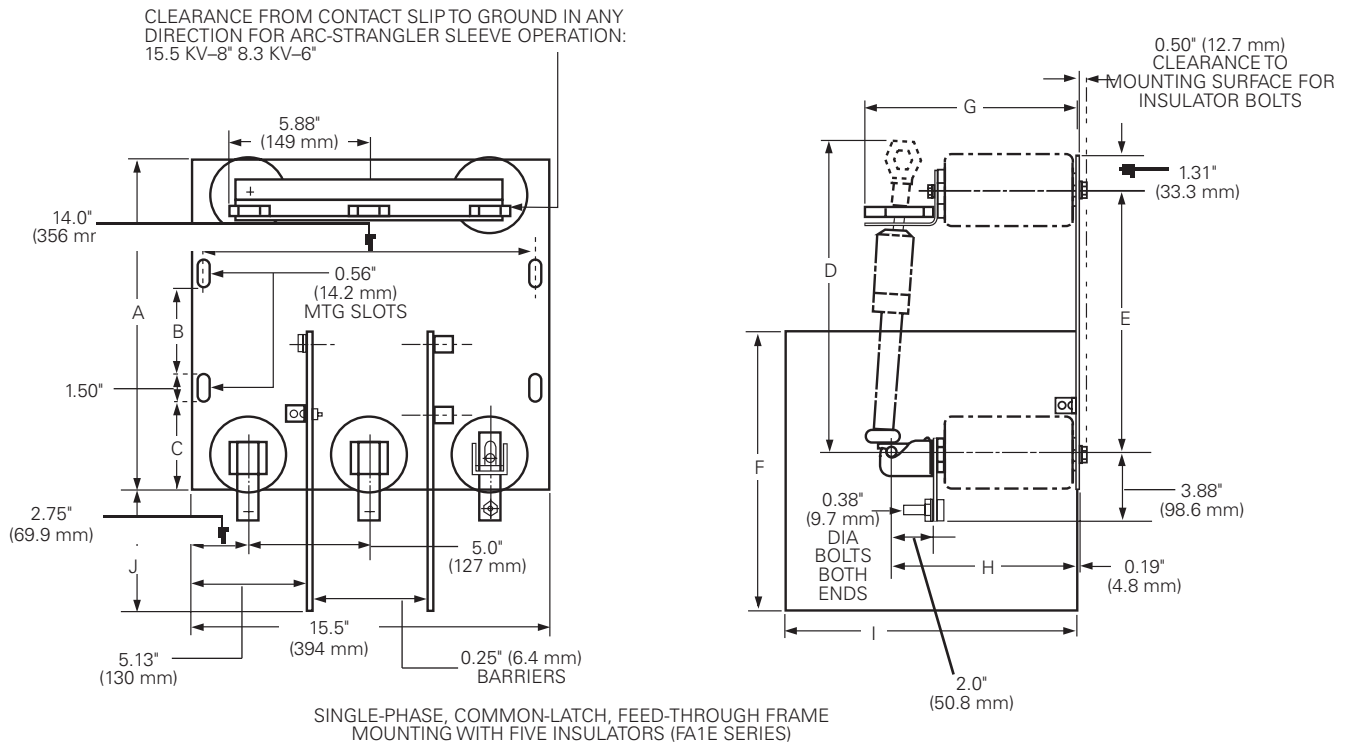

Figure 8. Single-phase common latch feed-through mounting frame FA1E series (Refer to Table 6 for dimensions).

Frame and box mountings (continued)

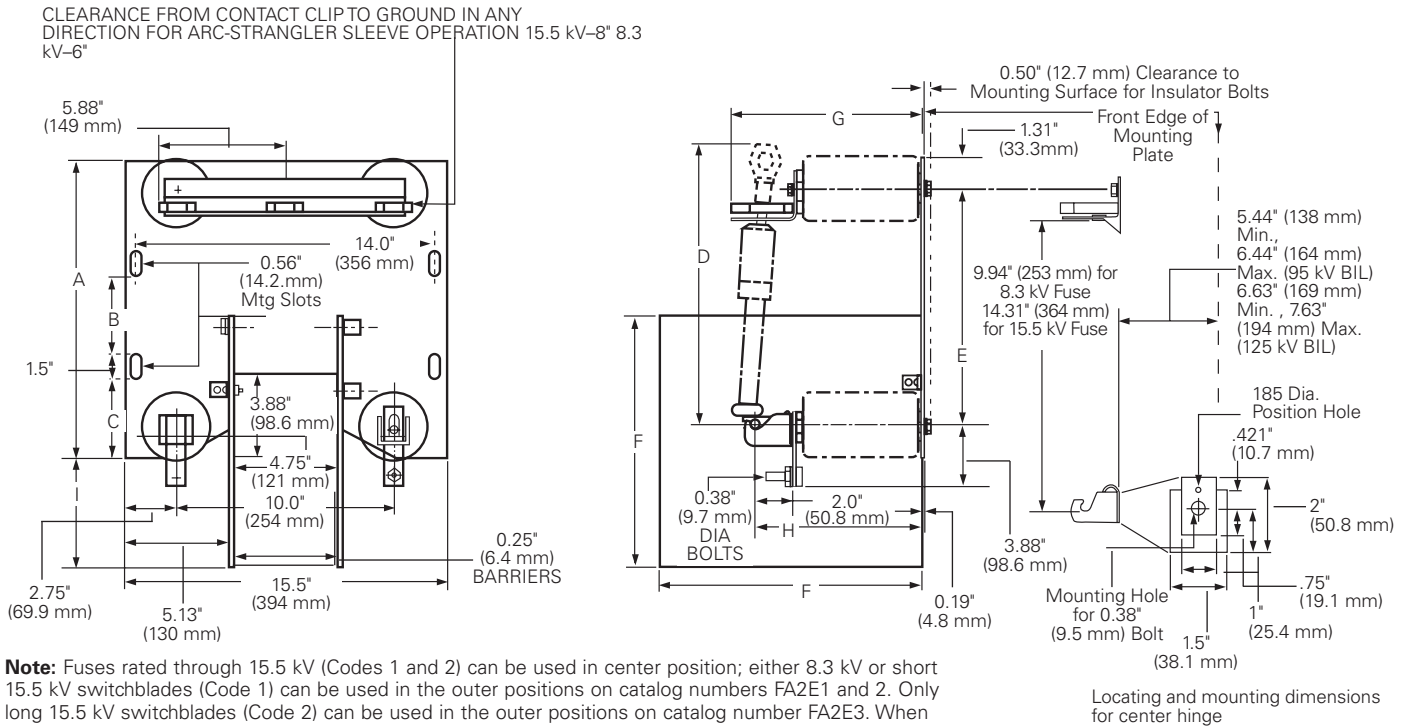

Figure 9. Single-phase common latch feed-through mounting frame FA2E (refer to Table 6 for dimensions).

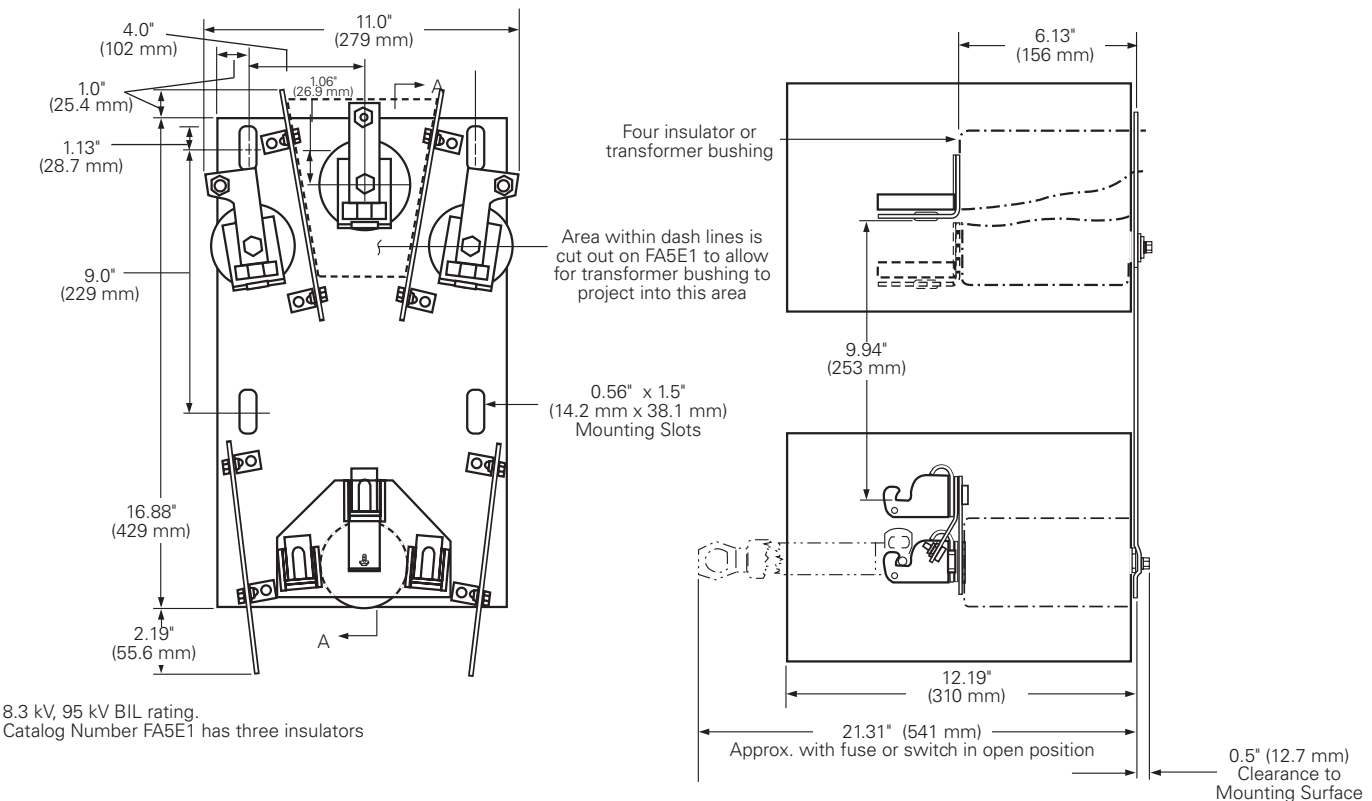

Figure 10. Single-phase common hinge feed-through VI-style mounting frame FA5E1 series (refer to Table 6 for dimensions).

Additional literature

Eaton has additional reference information available on NX, ELX and X-Limiter fuses.

CA132053EN ELX Full-Range Current-Limiting Fuse

CA132050EN X-Limiter Full-Range Current-Limiting Fuse

CA132049EN NX Indoor Current-Limiting Fuses

R240-60-6 Mounting Clearances-Type NX Fuses

Eaton
1000 Eaton Boulevard
Cleveland, OH 44122
United States
Eaton.com

Eaton's Power Systems Division
2300 Badger Drive
Waukesha, WI 53188
United States
Eaton.com/cooperpowerseries

© 2018 Eaton
All Rights Reserved
Printed in USA
Publication No. CA132046EN /
CSCC-1805-5504
June 2018

Eaton is a registered trademark.

All other trademarks are property
of their respective owners.

For Eaton's Cooper Power series fuse mount
product information call 1-877-277-4636 or
visit: www.eaton.com/cooperpowerseries.