

630 A deadbreak bolted tee connector - interface C



DTS624 – 24 kV applications

DTS636 – 36kV applications

Related products

- DRC400/436 Receptacle Cap
- DPC400/436 Connecting Plug

• Installation

- No special tools or heating are required
- Connector may be energized immediately after installation on its mating part
- Mates with bushings, plugs, and junction devices complying with interface C per CENELEC 50180 and 50181

Application

- For connection of extruded polymeric cable to transformers, switchgear, motors and other equipment with a premoulded separable connector
- For indoor and outdoor installations
- System voltage up to 36 kV
- Continuous current 630 A (900 A overload for 8 hours)
- Cable particulars:
 - Extruded polymeric cable (XLPE, EPR, etc.)
 - Copper or aluminum conductors
 - Semiconducting or metallic screens
- Conductor size: 12 kV 25-300 mm²
24 kV 25-300 mm²
36kV 25-240 mm²

Features

- Provides a fully screened and fully submersible separable connection when mated with the proper bushing or plug
- Built-in capacitive test point allows for an easy check of the circuit status or installation of a fault indicator
- No minimum phase clearance requirements
- Mounting can be vertical, horizontal, or any angle in between
- 100% factory tested
 - AC Withstand
 - Partial Discharge

Standards

- Meets the requirements of IEC 60502-4 and CENELEC HD 629.1 S2

EATON

Powering Business Worldwide

Features and detailed description

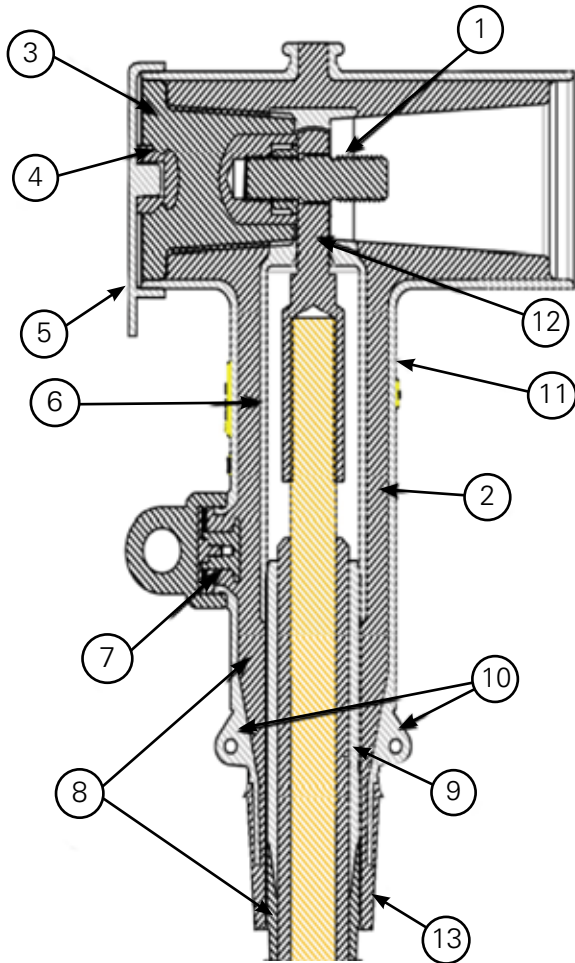

Figure 1. DTS624/DTS636 deadbreak tee connector.

1. **Clamping Screw**
Tin-plated brass screw secures the conductor contact to the bushing
2. **Insulation**
Moulded EPDM insulating rubber is formulated and mixed in-house to ensure high quality
3. **Basic Insulating Plug**
Moulded epoxy part has a threaded metal insert to accept the clamping screw
4. **Capacitive Test Point**
Capacitive test point provides means to check circuit status
5. **Rubber Cap**
Moulded EPDM conducting rubber cap protects and earths the test point during normal operation, includes pulling eye
6. **Internal Screen**
Moulded EPDM conducting rubber screen controls electrical stress
7. **Capacitive Test Point (Optional)**
Provides a means to mount a fault indicator. A moulded EPDM conducting rubber cap provides a watertight seal.
8. **Stress Relief**
The configuration of the outer screen and the cable adapter provide cable stress relief
9. **Cable Adapter**
The sized opening provides an interference fit to maintain a watertight seal and provides the initial cable stress relief
10. **Earthing Eyes**
Moulded into the external screen for connection of an earthing wire
11. **External Screen**
Moulded EPDM conducting rubber provides an external screen at earth potential for operator safety
12. **Conductor Contact**
Inertia welded bimetallic compression connector accepts copper or aluminum conductors
13. **Screen Break**
Insulation added to the outer screen to provide a screen break for cable screen testing. Also available without screen break.

Quality assurance

- Our manufacturing facility is registered to ISO 9001 by third party audit
- Required Production Tests
- Periodic X-Ray Analysis

Packaging

- Supplied in a kit with all necessary parts, approximate weight 3 kg

Table 1. Electrical Ratings

	DTS624	DTS636
Maximum System Voltage (U_m)	24 kV	36 kV
Impulse	125 kV	170 kV
AC Withstand (5 min.)	54 kV	81 kV
Continuous Current	630 A	630 A
Overload (8 hrs. Max.)	900 A	900 A
Short Circuit Withstand, 1 sec. (rms sym)	35 kA	35 kA

Notes: Ratings are based on IEC Standards and do not reflect maximum capability.

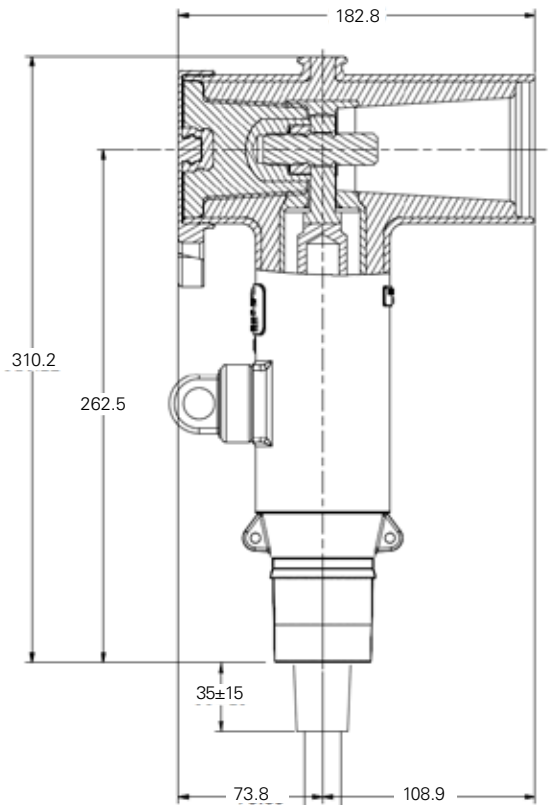

Figure 2. DTS624 deadbreak tee connector dimensional information.

Kit contents

The complete kit includes 1 each moulded tee housing, cable adapter, conductor contact, insulating plug, rubber cap, clamping screw, silicone lubricant, and installation instructions.

Ordering Information

To order a 24kV or a 36kV bolted tee connector, see the following Steps 1-3.

Step 1

Determine the required voltage rating for the tee connector and whether a test point is required or not. Pick the basic catalog number from the list below:

- 24 kV with test point DTS624**R2C3**TSB*
- 24 kV without test point DTS624**R2C3**SB*
- 36 kV with test point DTS636**R2C3**TSB*
- 36 kV without test point DTS636**R2C3**SB*

* Remove "SB" for non-screen break option.

Table R2. Cable Insulation Range

Insulation Range Designation	Cable Insulation Range Ø (mm)	
	Min.	Max.
AA	13.5	17.2
A	16.3	19.3
B	18.3	21.0
C	20.0	24.1
D	23.1	27.0
E	25.6	29.0
F	27.7	32.6
G	30.9	36.2
H	34.0	39.5

Step 2

Determine the cable's diameter over insulation. Then identify a cable range from Table R2 that covers the minimum and maximum insulation diameters. Select the correct cable range code from table **R2** and insert into the catalog number determined in Step 1.

Step 3

Identify the conductor size and type in Table **C3** and select the conductor code from the appropriate column (DIN style, EDF style or Mechanical Connector style). Insert the selected code in the catalog number determined in Step 1.

Ordering Example: For 20 kV cable, 240 mm² copper conductor, 31.0 mm core insulation diameter, DIN connector, and without a test point, specify DTS624F240SB.

Cable seal adaptors are sold separately

Table C3. Conductor Code

Stranded Conductor Size (mm ²)	DIN Type	EDF Type	Mechanical Type
25	25	E25	S150
35	35	E35	S150
50	50	E50	S150
70	70	E70	S150
95	95	E95	S150
120	120	E120	S150
150	150	E150	S150
185	185	E185	S300
240	240	E240	S300
300	300	-	S300

Notes: Bimetallic connectors can be used with aluminum or copper conductors.

Eaton
1000 Eaton Boulevard
Cleveland, OH 44122
United States
Eaton.com

Eaton's Power Systems Division
2300 Badger Drive
Waukesha, WI 53188
Eaton.com/cooperpowerseries

© 2016 Eaton
All Rights Reserved
Printed in USA
Publication No. CA650030EN

Eaton is a registered trademark.

All trademarks are property
of their respective owners.



Powering Business Worldwide