

630 A deadbreak bolted tee connector - interface C



DT400 - 24 kV applications

DT436 - 36 kV applications

Related products

- DPC400/DPC436 Connecting Plug
- DRC400/DRC436 Receptacle Cap

Installation

- No special tools, heating, taping, or potting are required.
- Connector may be energized immediately after installation on its mating part.
- Mates with bushings, plugs, and junction devices complying with interface C per CENELEC 50180 and 50181.

Application

- For connection of extruded polymeric cable to transformers, switchgear, motors and other equipment with a premoulded separable connector.
- For indoor and outdoor installations.
- System voltage up to 36 kV.
- Continuous current 630 A (900 A overload for 8 hours).
- Cable particulars:
 - Extruded polymeric cable (XLPE, EPR, etc.)
 - Copper or aluminum conductors
 - Semiconducting or metallic screens
- Conductor size: 12 kV 70-400 mm²
24 kV 25-400 mm²
36 kV 25-240 mm²

Features

- Provides a fully screened and fully submersible separable connection when mated with proper bushing or plug.
- Built-in capacitive test point allows for an easy check of the circuit status or installation of a fault indicator.
- No minimum phase clearance requirements.
- Mounting can be vertical, horizontal, or any angle in between.
- 100% factory tested.
 - AC withstand
 - Partial Discharge

Standards

- Meets the requirements of CENELEC HD629.1 S2 and IEC 60502-4.

EATON

Powering Business Worldwide

Quality assurance

- Our manufacturing facility is registered to ISO 9001 by third party audit.
- Required Production Tests
- Periodic X-Ray Analysis

Packaging

- Supplied in a kit with all necessary parts, approximate weight 3 kg.

Features and detailed description

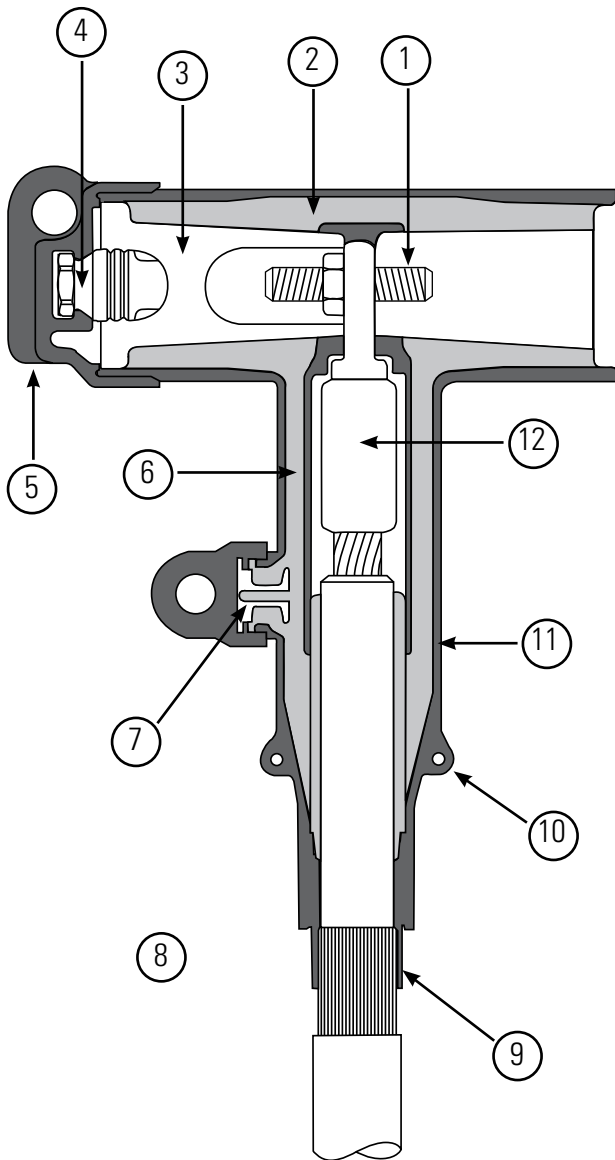

Table 1. Electrical Ratings

| | DT400 | DT436 |
|--|--------|--------|
| Maximum System Voltage (Um) | 24 kV | 36 kV |
| Impulse | 125 kV | 170 kV |
| AC Withstand (5 min.) | 54 kV | 81 kV |
| Continuous Current | 630 A | 630 A |
| Overload (8 hrs. Max.) | 900 A | 900 A |
| Short Circuit Withstand, 1 sec (rms sym) | 35 kA | 35 kA |

1. Clamping Screw

Tin-plated copper screw secures the conductor contact to the bushing

2. Insulation

Moulded EPDM insulating rubber is formulated and mixed in our facility in the USA to ensure high quality

3. Basic Insulating Plug

Moulded epoxy part has a threaded metal insert to accept the clamping screw

4. Capacitive Test Point

Capacitive test point provides means to check circuit status

5. Rubber Cap

Moulded EPDM conducting rubber cap protects and earths the test point during normal operation

6. Internal Screen

Moulded EPDM conducting rubber screen controls electrical stress

7. Capacitive Test Point (Optional)

Provides a means to mount a fault indicator. A moulded EPDM conducting rubber cap earths the test point when not in use.

8. Stress Relief

The configuration of the outer screen and the cable adapter provide cable stress relief

9. Cable Adapter

The sized opening provides an interference fit to maintain a watertight seal and provides the initial cable stress relief

10. Earthing Eyes

Moulded into the external screen for connection of an earthing wire

11. External Screen

Moulded EPDM conducting rubber mates with the cable screen to maintain screen continuity and ensure that the assembly is at earth potential

12. Conductor Contact

Inertia welded bimetallic compression connector accepts copper or aluminum conductors

Figure 1. 630 A - 24 and 36 kV Class deadbreak tee connector.

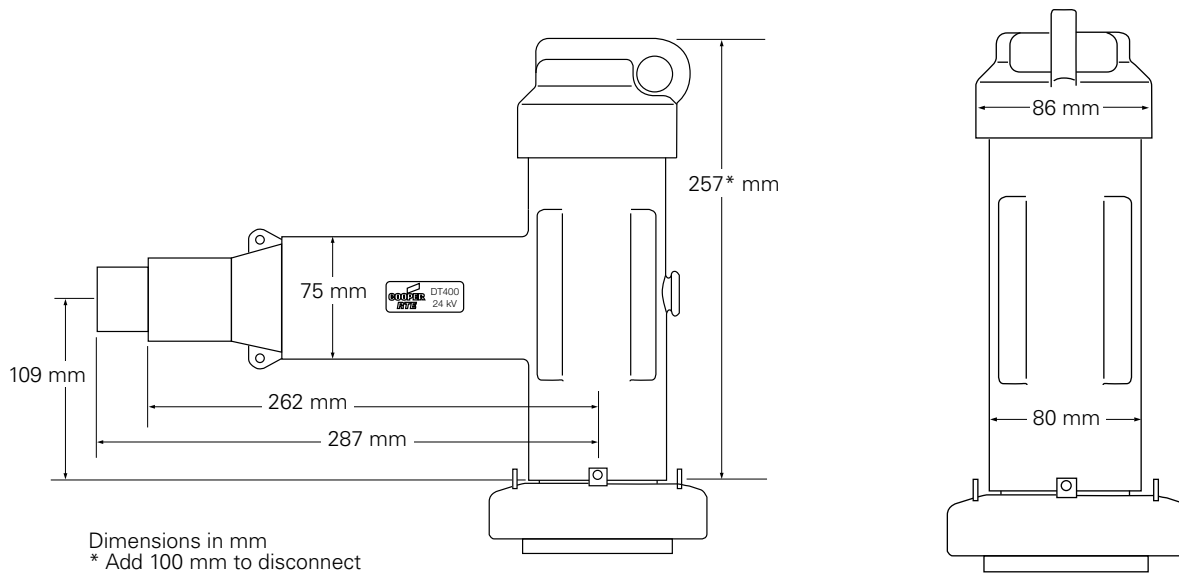

Figure 2. DT400/DT436 deadbreak tee connector dimensional information.

Kit contents

The complete kit includes 1 each moulded tee housing, cable adapter, conductor contact, insulating plug, rubber cap, clamping screw, silicone lubricant, and installation instructions.

Ordering information

For 24 kV the complete catalog number for the tee connector is DT400RC.

For 36 kV, the complete catalog number for the tee connector is DT436RC.

R is the cable range designation and C is the conductor contact code. Select the cable range designation from Table 2. Select the conductor contact code from Table 3 for the conductor size and type of connector required.

Table 2. Cable Insulation Range

| Insulation Range Designation | Cable Insulation Range Ø (mm) | |
|------------------------------|-------------------------------|------|
| | Min. | Max. |
| AA | 13.5 | 17.2 |
| A | 16.3 | 19.3 |
| B | 18.3 | 21.0 |
| C | 20.0 | 24.1 |
| D | 23.1 | 27.0 |
| E | 25.6 | 29.0 |
| F | 27.7 | 32.6 |
| G | 30.9 | 36.2 |
| H | 34.0 | 39.5 |

Optional Test Point

If a test point on the tee body is required, add a "T" before the insulation range designation.

Example: DT400TF240

Ordering Example: For 20 kV cable, 240 mm² aluminum conductor, 31.0 mm core insulation diameter, DIN connector, specify DT400F240.

Cable seal adapters are ordered separately.

Table 3. Conductor Code

| Stranded Conductor Size (mm ²) | DIN Type | EDF Type |
|--|----------|----------|
| 25 | 25 | E25 |
| 35 | 35 | E35 |
| 50 | 50 | E50 |
| 70 | 70 | E70 |
| 95 | 95 | E95 |
| 120 | 120 | E120 |
| 150 | 150 | E150 |
| 185 | 185 | E185 |
| 240 | 240 | E240 |
| 300 | 300 | - |
| 400 | 400 | - |

Note: Bimetallic connectors can be used with aluminum or copper conductors.

Eaton
1000 Eaton Boulevard
Cleveland, OH 44122
United States
Eaton.com

Eaton's Cooper Power Systems Division
2300 Badger Drive
Waukesha, WI 53188
Eaton.com/cooperpowerseries

© 2015 Eaton
All Rights Reserved
Printed in USA
Publication No. CA650028EN

Eaton and Cooper Power are valuable
trademarks of Eaton in the U.S. and other
countries. You are not permitted to use
these trademarks without the prior written
consent of Eaton.