

## 600 A PUSH-OP™ deadbreak connector operation instructions

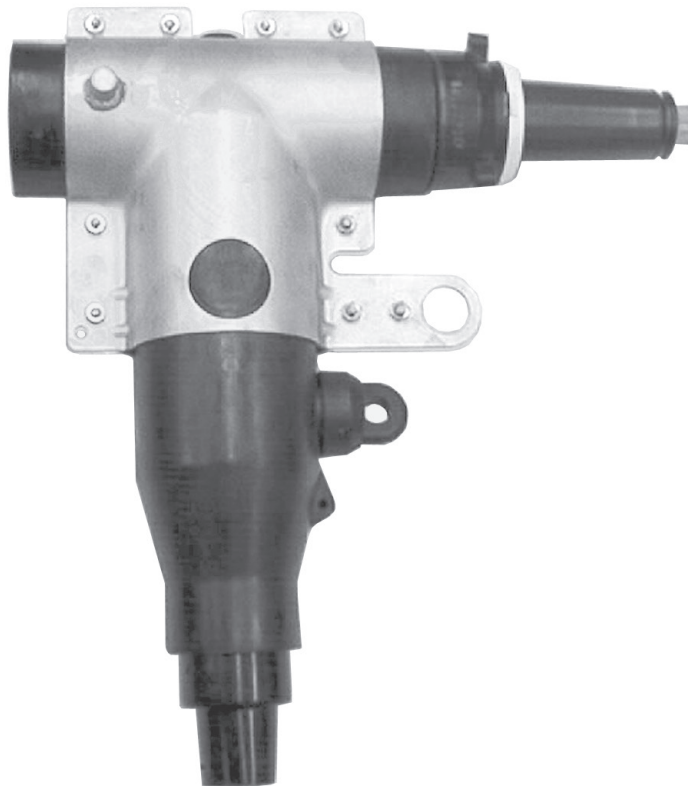

## **DISCLAIMER OF WARRANTIES AND LIMITATION OF LIABILITY**

The information, recommendations, descriptions and safety notations in this document are based on Eaton Corporation's ("Eaton") experience and judgment and may not cover all contingencies. If further information is required, an Eaton sales office should be consulted. Sale of the product shown in this literature is subject to the terms and conditions outlined in appropriate Eaton selling policies or other contractual agreement between Eaton and the purchaser.

THERE ARE NO UNDERSTANDINGS, AGREEMENTS, WARRANTIES, EXPRESSED OR IMPLIED, INCLUDING WARRANTIES OF FITNESS FOR A PARTICULAR PURPOSE OR MERCHANTABILITY, OTHER THAN THOSE SPECIFICALLY SET OUT IN ANY EXISTING CONTRACT BETWEEN THE PARTIES. ANY SUCH CONTRACT STATES THE ENTIRE OBLIGATION OF EATON. THE CONTENTS OF THIS DOCUMENT SHALL NOT BECOME PART OF OR MODIFY ANY CONTRACT BETWEEN THE PARTIES.

In no event will Eaton be responsible to the purchaser or user in contract, in tort (including negligence), strict liability or otherwise for any special, indirect, incidental or consequential damage or loss whatsoever, including but not limited to damage or loss of use of equipment, plant or power system, cost of capital, loss of power, additional expenses in the use of existing power facilities, or claims against the purchaser or user by its customers resulting from the use of the information, recommendations and descriptions contained herein. The information contained in this manual is subject to change without notice.

**Contents**

**SAFETY INFORMATION**

Safety information ..... **iv**

**PRODUCT INFORMATION**

Introduction ..... **1**  
Acceptance and initial inspection ..... **1**  
Handling and storage ..... **1**  
Standards ..... **1**

**OPERATING INSTRUCTIONS**

Equipment required ..... **2**  
Isolating and grounding a cable requiring repair ..... **3**  
Reconnecting cable to apparatus bushings ..... **7**



## Safety for life



Eaton meets or exceeds all applicable industry standards relating to product safety in its Cooper Power™ series products. We actively promote safe practices in the use and maintenance of our products through our service literature, instructional training programs, and the continuous efforts of all Eaton employees involved in product design, manufacture, marketing, and service.

We strongly urge that you always follow all locally approved safety procedures and safety instructions when working around high voltage lines and equipment, and support our “Safety For Life” mission.

### Safety information

The instructions in this manual are not intended as a substitute for proper training or adequate experience in the safe operation of the equipment described. Only competent technicians who are familiar with this equipment should install, operate, and service it.

A competent technician has these qualifications:

- Is thoroughly familiar with these instructions.
- Is trained in industry-accepted high and low-voltage safe operating practices and procedures.
- Is trained and authorized to energize, de-energize, clear, and ground power distribution equipment.
- Is trained in the care and use of protective equipment such as arc flash clothing, safety glasses, face shield, hard hat, rubber gloves, clampstick, hotstick, etc.

Following is important safety information. For safe installation and operation of this equipment, be sure to read and understand all cautions and warnings.

#### Hazard Statement Definitions

This manual may contain four types of hazard statements:

#### DANGER

Indicates an imminently hazardous situation which, if not avoided, will result in death or serious injury.

#### WARNING

Indicates a potentially hazardous situation which, if not avoided, could result in death or serious injury.

#### CAUTION

Indicates a potentially hazardous situation which, if not avoided, may result in minor or moderate injury.

#### CAUTION

Indicates a potentially hazardous situation which, if not avoided, may result in equipment damage only.

#### Safety instructions

Following are general caution and warning statements that apply to this equipment. Additional statements, related to specific tasks and procedures, are located throughout the manual.

#### DANGER

**Hazardous voltage. Contact with hazardous voltage will cause death or severe personal injury. Follow all locally approved safety procedures when working around high- and low-voltage lines and equipment.**

G103.3

#### WARNING

**Before installing, operating, maintaining, or testing this equipment, carefully read and understand the contents of this manual. Improper operation, handling or maintenance can result in death, severe personal injury, and equipment damage.**

G101.0

#### WARNING

**This equipment is not intended to protect human life. Follow all locally approved procedures and safety practices when installing or operating this equipment. Failure to comply can result in death, severe personal injury and equipment damage.**

G102.1

#### WARNING

**Power distribution and transmission equipment must be properly selected for the intended application. It must be installed and serviced by competent personnel who have been trained and understand proper safety procedures. These instructions are written for such personnel and are not a substitute for adequate training and experience in safety procedures. Failure to properly select, install or maintain power distribution and transmission equipment can result in death, severe personal injury, and equipment damage.**

G122.3

## Product information

### Introduction

Eaton's Cooper Power™ series 600 A, 15, 25, and 35 kV Class PUSH-OP™ deadbreak connector offers a complete threadless deadbreak, hotstick operable connection system for terminating underground cables to transformers, switches, switchgear, and other apparatus. It is fully shielded, submersible, and meets the requirements of IEEE Std 386™-2006 standard - Separable Insulated Connector Systems. *Service Information MN650011EN* provides operation instructions.

---

### WARNING

---

**600 A PUSH-OP connectors are designed to be operated in accordance with normal safe operating procedures. These instructions are not intended to supersede or replace existing safety and operating procedures. Connectors must be de-energized during operation or maintenance. Visible break and adequate grounding must be provided before cable work proceeds. (Ensure that the component is rated for the intended application before it is installed.)**

**PUSH-OP connectors should be installed and serviced only by personnel familiar with good safety practice and the handling of high-voltage electrical equipment. Failure to comply may result in death, severe personal injury or equipment damage.**

---

### Read this manual first

Read and understand the contents of this manual and follow all locally approved procedures and safety practices before installing or operating this equipment.

### Additional information

These instructions cannot cover all details or variations in the equipment, procedures, or process described nor provide directions for meeting every possible contingency during installation, operation, or maintenance. For additional information, contact your Eaton representative.

### Acceptance and initial inspection

Each PUSH-OP connector is in good condition when accepted by the carrier for shipment. Upon receipt, inspect the shipping container for signs of damage. Unpack the PUSH-OP connector and inspect it thoroughly for damage incurred during shipment. If damage is discovered, file a claim with the carrier immediately.

### Handling and storage

Be careful during handling and storage of the PUSH-OP connector to minimize the possibility of damage. If the PUSH-OP connector is to be stored for any length of time prior to installation, provide a clean, dry storage area.

### Standards

ISO 9001 Certified Quality Management System

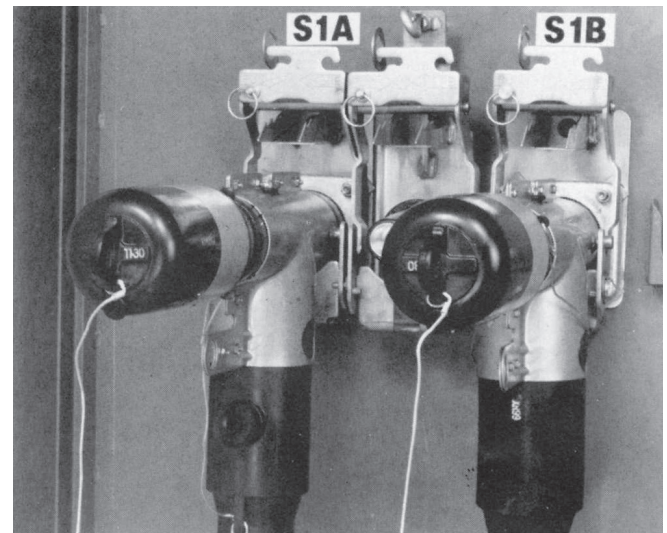

Figure 1. 600 A PUSH-OP Connector

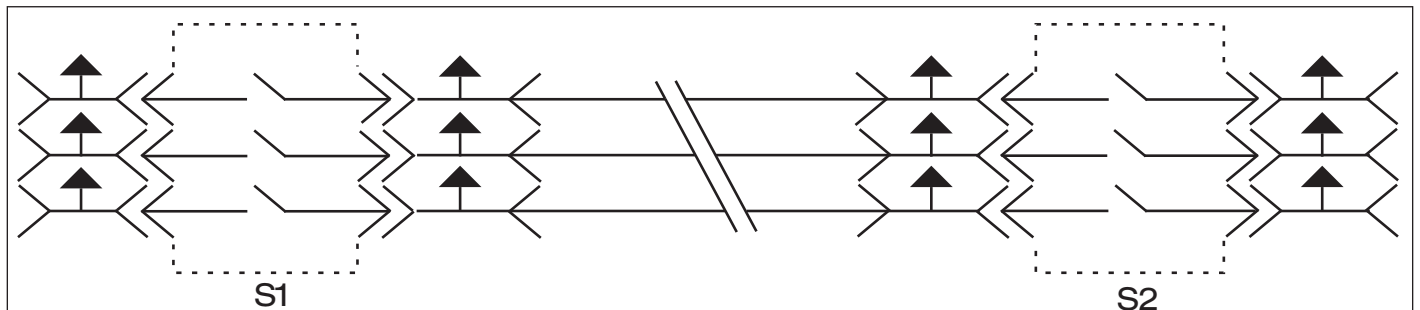

Figure 2. One-line diagram of a three-phase cable connected to a three-phase switch on either end.

## Operation instructions

### Equipment Required

- One (1) Test Probe
- Three (3) Grounding Elbows
- Three (3) PUSH-OP Insulated Standoff Bushings
- Three (3) PUSH-OP Bushing Adapters with Insulated Protective Caps
- One (1) Hotstick
- One (1) Voltage Detector
- Personal Protective Equipment
- Insulating Rubber Blanket
- Silicone Grease

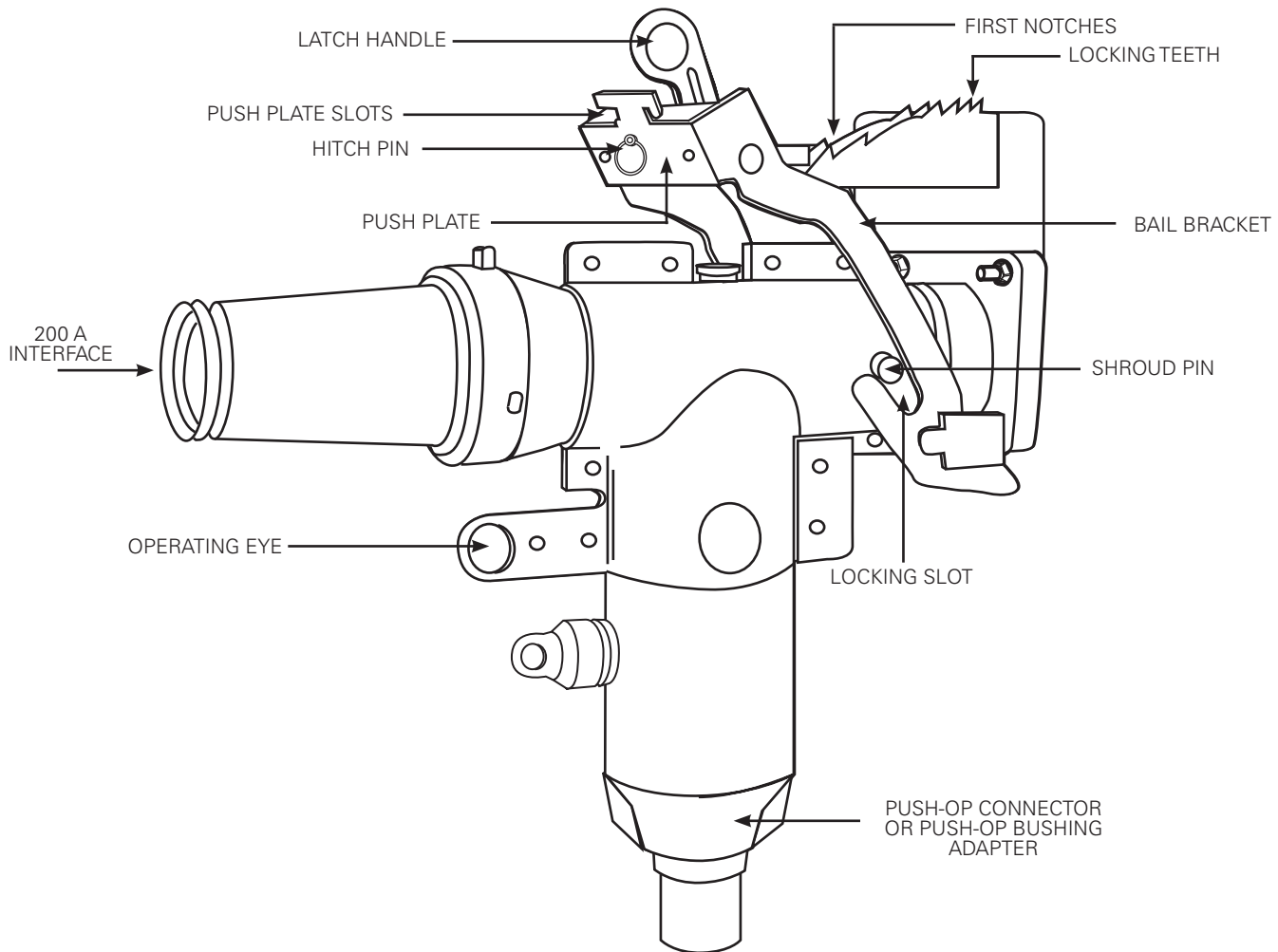

Figure 3. Line illustration of the PUSH-OP connector.

## Isolating and grounding a cable requiring repair

### Step 1.

#### De-energize cables

- Open switches at both ends of the cable to be isolated. Refer to Figure 4.
- Determine that there is adequate working room around the connectors for parking the insulated standoff bushings and training the cables.
- Determine that there is adequate working room for handling hotstick around apparatus cabinet.
- Place insulating rubber blanket on the ground directly in front of connectors.
- Inspect and test all operating equipment for serviceability.
- Connect grounding elbow to system ground.
- Connect ground leads of protective caps to system ground.

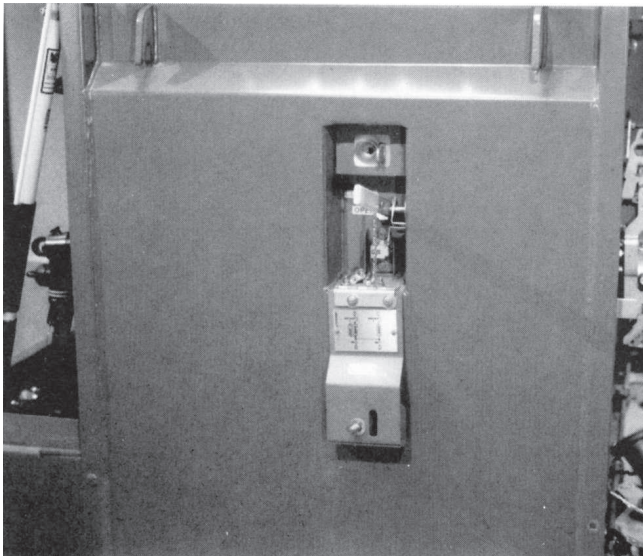

Figure 4. De-energized cables.

### Step 2.

#### Determine that cables are de-energized

- Remove 200 A protective cap or arrester from PUSH-OP connectors using hotstick and set aside in a clean, protected area.
- Insert test probe into 200 A interface using hotstick. Refer to Figure 5.
- Test for voltage by fuzzing or by using voltage detector designed for connectors. Remove probe after testing.

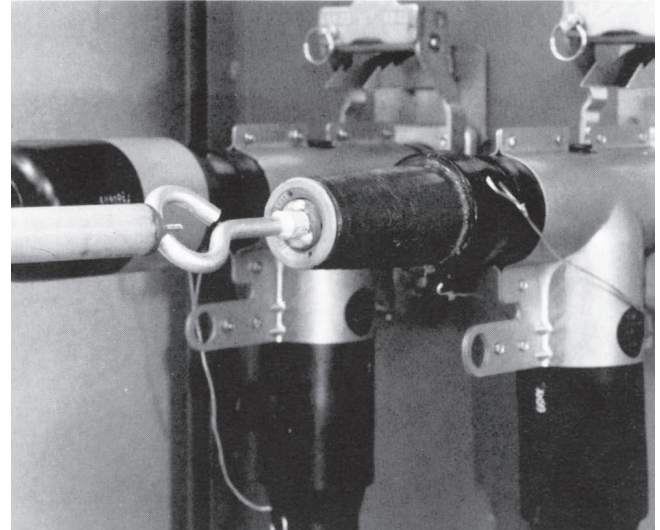

Figure 5. Test for voltage with test probe.

---

### **⚠ WARNING**

---

**Hazardous Voltage. Do not proceed until cable is de-energized. Failure to comply may result in death, severe personal injury or equipment damage.**

---

### Step 3.

#### Provide a visible ground

- Close grounding elbow into PUSH-OP 200 A interface using a hotstick. Refer to Figure 6.

---

### **⚠ WARNING**

---

**Hazardous Voltage. Ground all three phases (Steps 2 and 3) before proceeding. Failure to comply may result in death, severe personal injury or equipment damage.**

---

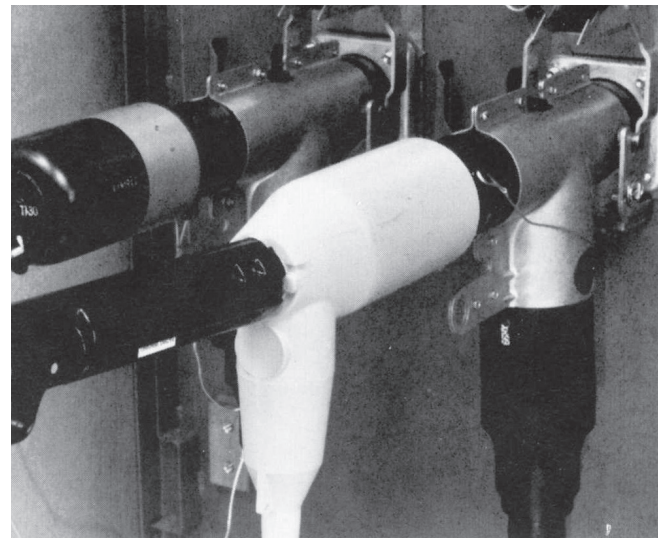

Figure 6. Provide a visible ground with a grounding elbow.

#### Step 4

##### Provide a visible break

- Clean and lubricate PUSH-OP insulated standoff bushing.
- Mount PUSH-OP insulated standoff bushing in the apparatus parking pocket using a hotstick. Tighten eyebolt to ensure secure mounting. Ensure that PUSH-OP bail bracket on the insulated standoff bushing is unlatched. Refer to Figure 7.

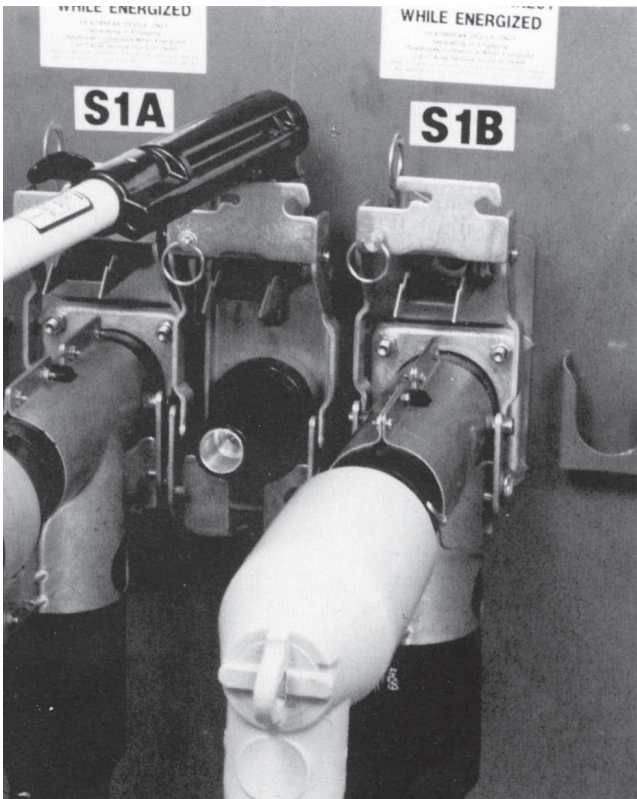

Figure 7. Mount PUSH-OP standoff bushing.

- Unthread the hitch pin on the push plate. Refer to Figure 8.

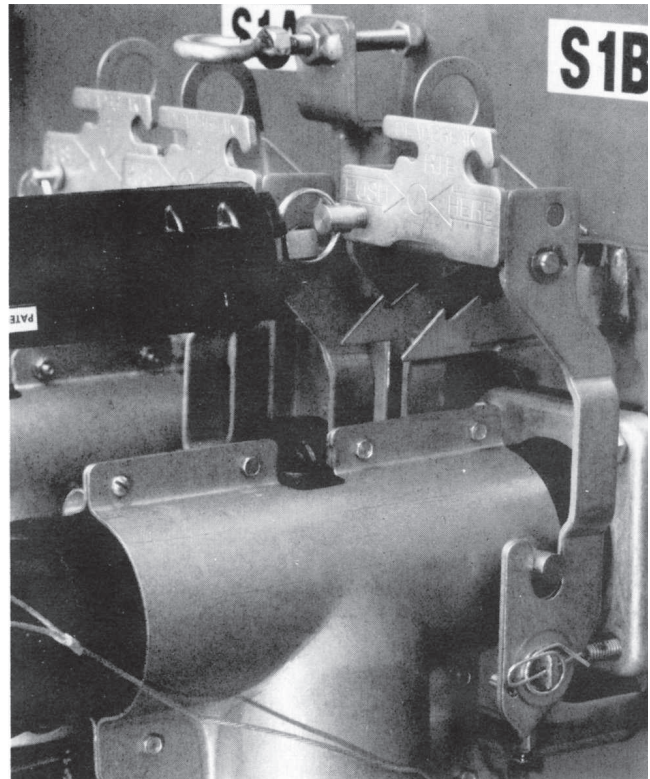
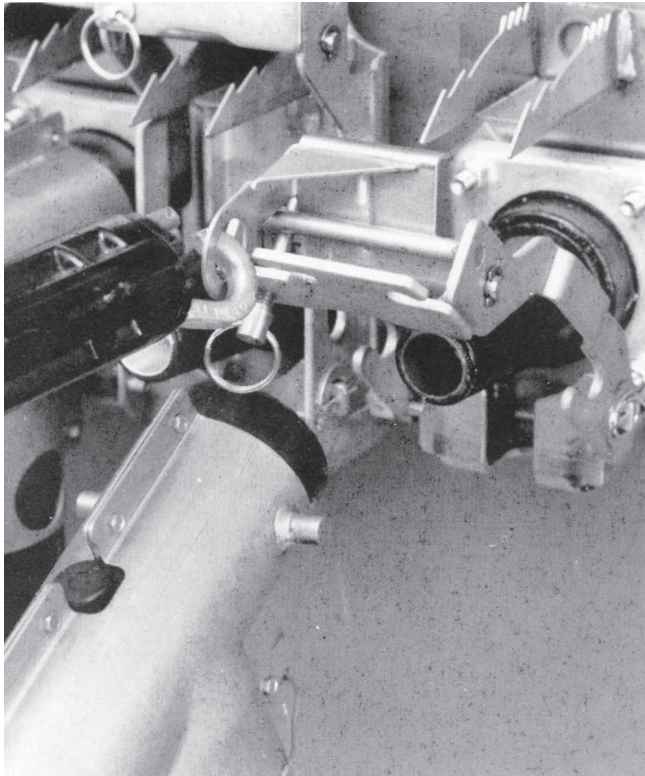

Figure 8. Unthread the hitch pin.





**Figure 9. Pull back on PUSH-OP latch handle.**

- Grasp PUSH-OP latch handle with shotgun stick and pull backward until PUSH-OP connector is completely unseated. Refer to Figure 9.
- Grasp PUSH-OP connector operating eye with hotstick. Pull eye completely into hotstick.
- Move PUSH-OP connector to insulated bushing, engaging shroud locating pins in bail bracket locking slots until latch plate engages first notches. NOTE: It is not necessary to remove the grounding elbow from the 200 A interface during this operation. Refer to Figure 10.

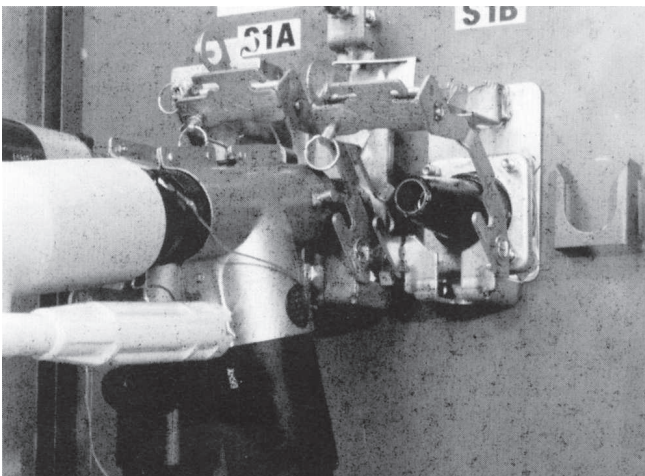

**Figure 10. Move PUSH-OP connector to insulated bushing.**

- Push forward on push plate with hotstick until a bump is felt and latch plate has engaged locking teeth. Refer to Figure 11.

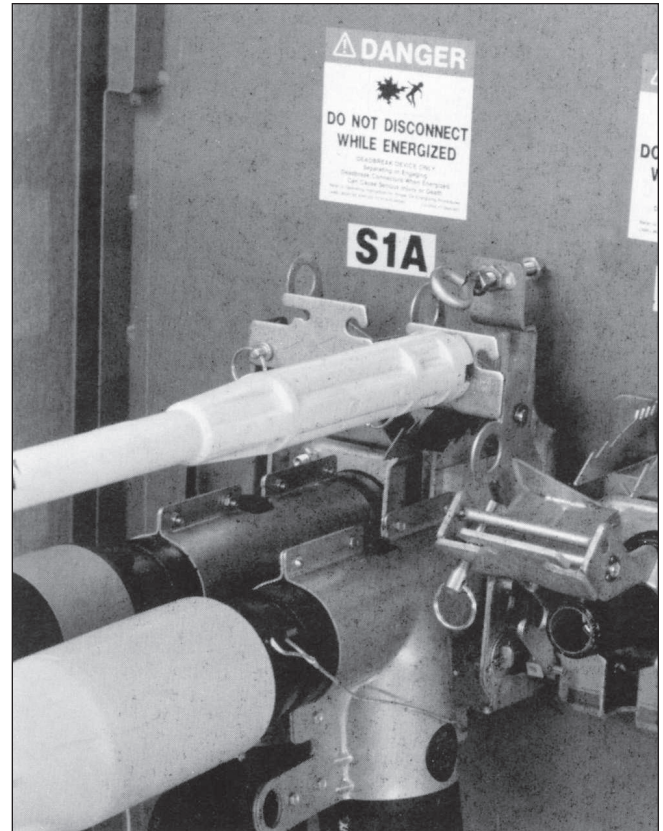

**Figure 11. Push forward on push plate.**

- Pull on push plate with hotstick to ensure that latch plate is engaged. Refer to Figure 12.
- Thread hitch pin clockwise until bail lock is secured.

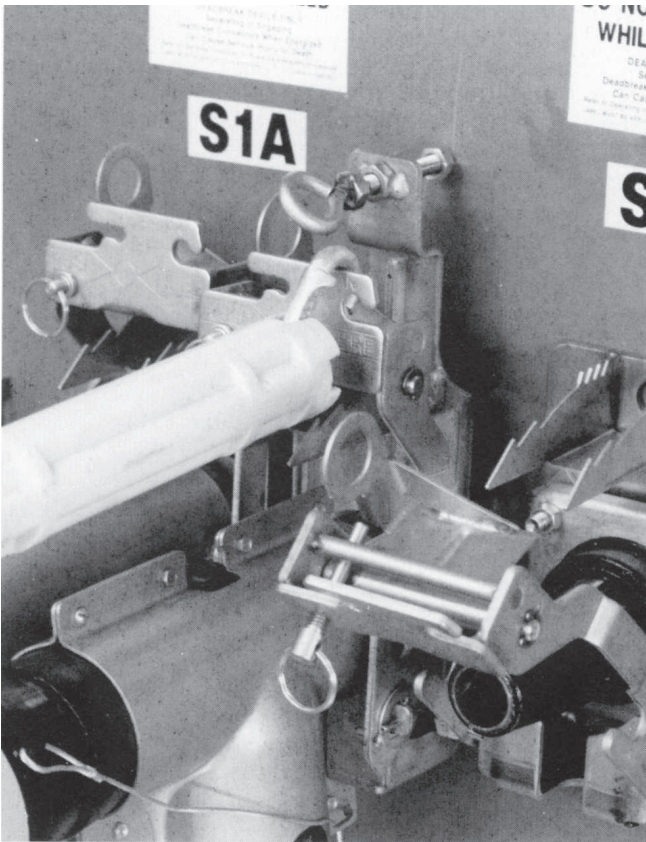

**Figure 12. Pull on push plate to ensure latch plate is engaged.**

- Clean and lubricate PUSH-OP bushing adapter interfaces.
- Grasp PUSH-OP bushing adapter operating eye with hotstick. Pull eye completely into hotstick and place adapter on exposed PUSH-OP apparatus bushing, engaging shroud locating pins in bail bracket locking slots and push until latch plate engages first notches. Refer to Figure 13.

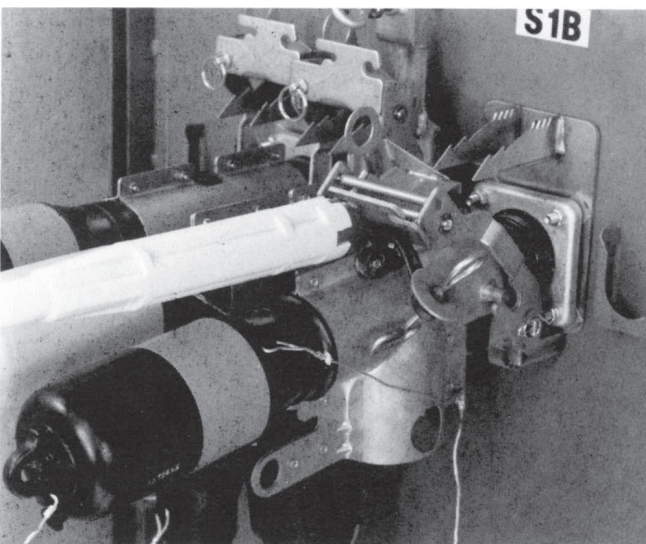

**Figure 13. Install adapter on PUSH-OP apparatus bushing.**

- Push forward on push plate with hotstick until a bump is felt and latch plate has engaged locking teeth.
- Pull on push plate with hotstick to ensure that latch plate is engaged. Refer to Figure 14.
- Place insulated protective cap on 200 A interface using hotstick.
- Thread hitch pin clockwise until bail lock is secured.

Complete Steps 2 through 4 for all three phases at both ends of cables.

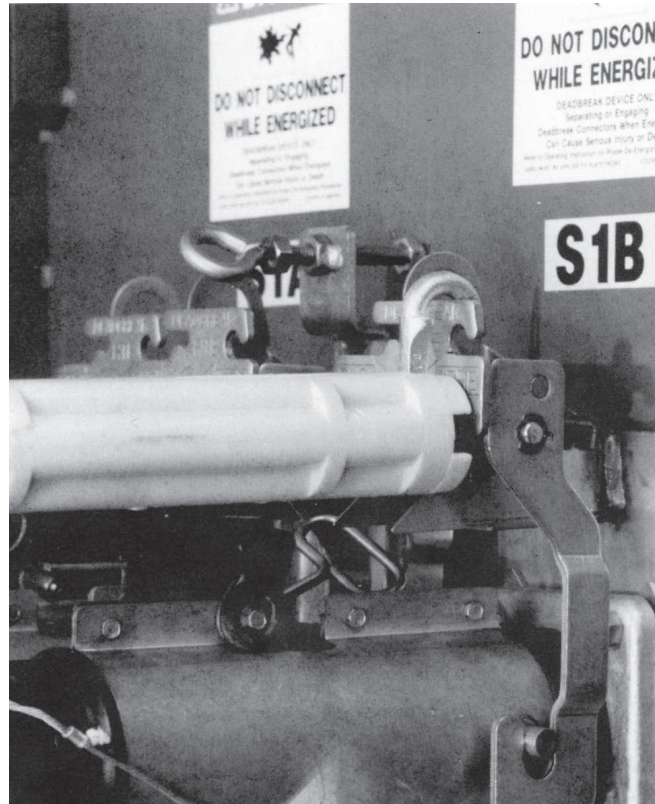

**Figure 14. Pull on push plate to ensure latch plate is engaged.**

## Reconnecting cable to apparatus bushings

### Step 1

#### Determine that bushings are de-energized

- Check apparatus switch and see that it is open. Open switch if it is closed. Refer to Figure 15.



Figure 15. Open switch if it is closed.

- Unthread hitch pin.
- Engage catch strap in push plate slots with hotstick. Refer to Figure 16.

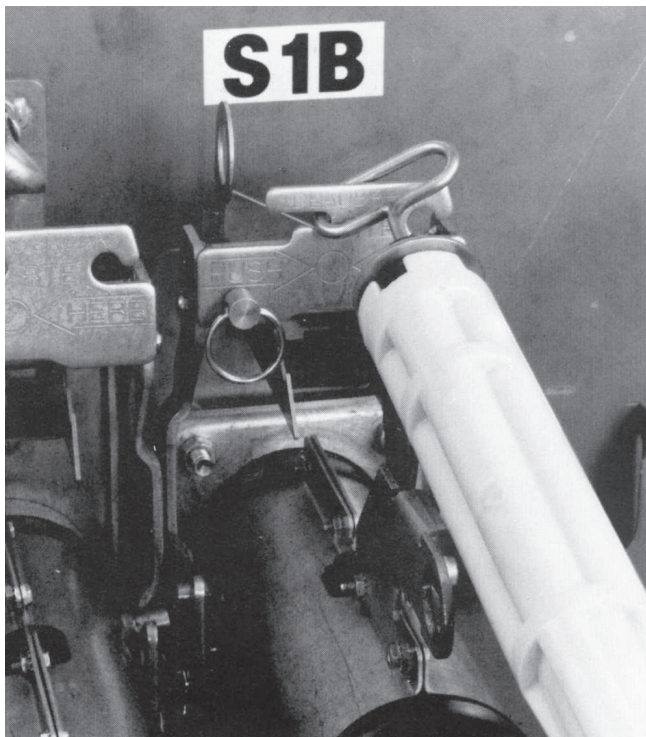

Figure 16. Engage catch strap in push plate slots.

- Use hotstick to remove 200 A protective cap or arrester from bushing adapter interface.
- Insert test probe into bushing adapter using hotstick. Refer to Figure 17.
- Test for voltage by fuzzing or by using voltage detector designed for connectors. Remove probe after testing.

---

### **⚠ WARNING**

---

**Hazardous Voltage. Do not proceed until cable is de-energized. Failure to comply may result in death, severe personal injury or equipment damage.**

---

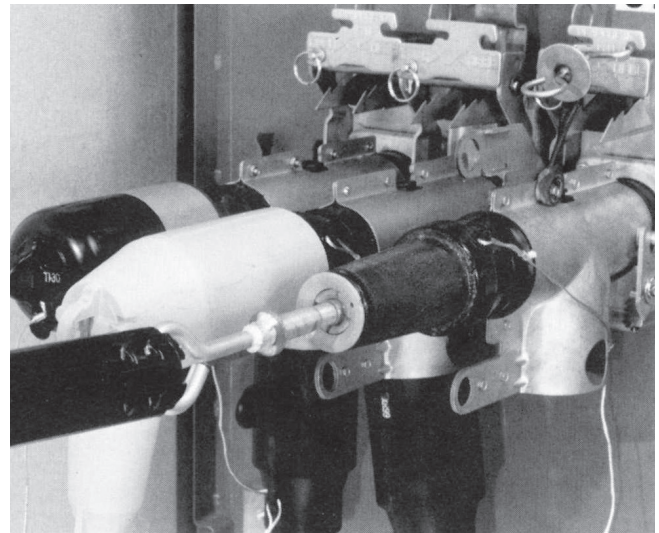
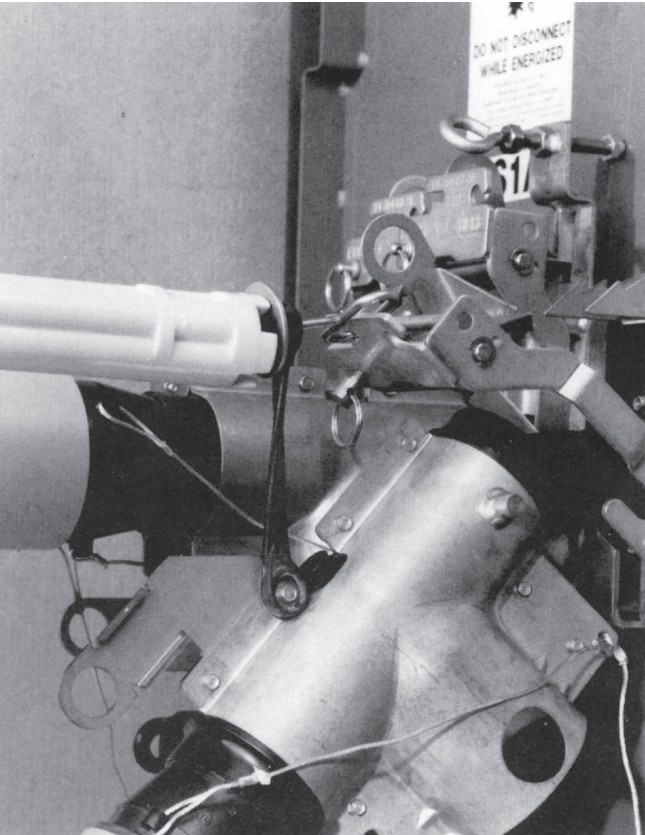

Figure 17. Test for voltage with test probe.

### Step 2

#### Connect cable to apparatus bushing

- Grasp latch handle of PUSH-OP bushing adapter (mounted on apparatus bushing) using hotstick and pull backward until bushing adapter is completely unseated. Remove bushing adapter by unhooking catch strap ring. Place bushing adapter in clean protected area. Refer to Figure 18.



**Figure 18. Pull back until bushing adapter is unsealed.**

- Unthread hitch pin.
- Grasp latch handle of PUSH-OP connector (mounted on insulated standoff bushing) using hotstick and pull backward until connector is completely unsealed. Refer to Figure 19.

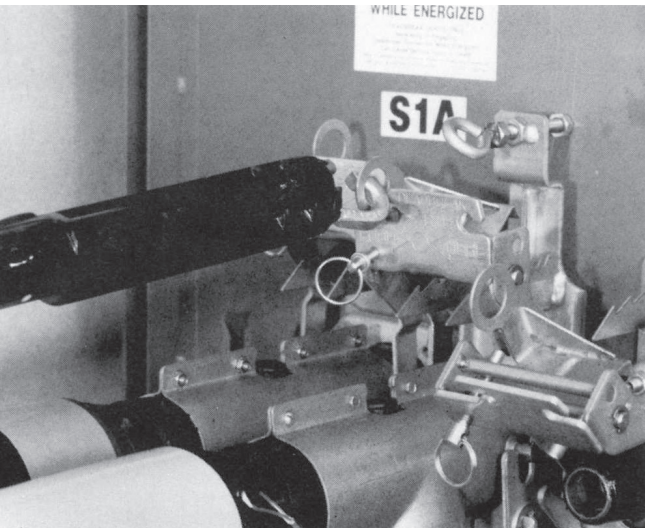

**Figure 19. Pull back until connector is unsealed.**

- Grasp PUSH-OP connector operating eye with hotstick. Pull eye completely into hotstick. Move connector to apparatus bushing, engaging shroud locating pins in bail bracket locking slots until latch plate engages first notches. Refer to Figure 20.

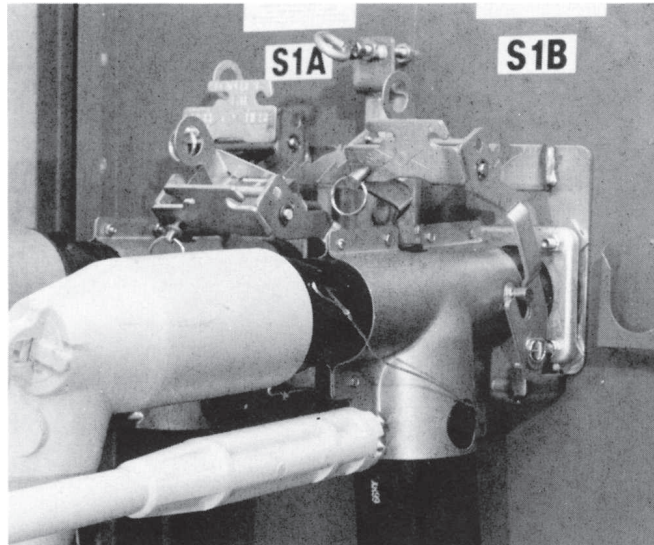

**Figure 20. Move connector to apparatus bushing.**

- Push forward on push plate with hotstick until a bump is felt and latch plate has engaged locking teeth. Pull on push plate with hotstick to ensure latch plate is engaged. Refer to Figure 21.
- Thread hitch pin clockwise until bail lock is secured.

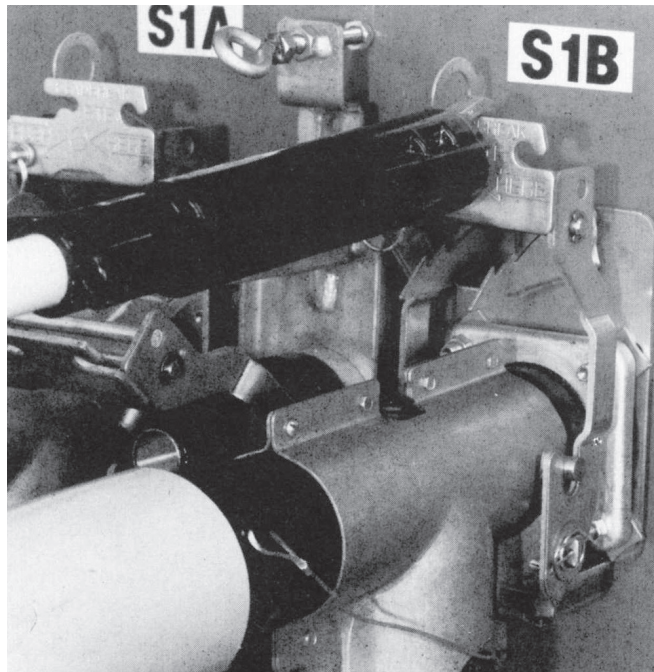

**Figure 21. Pull on push plate to ensure latch plate is engaged.**

- Remove grounding elbow from connector using hotstick.
- Place 200 A insulated protective cap or arrester on 200 A connector interface using hotstick. Refer to Figure 22.

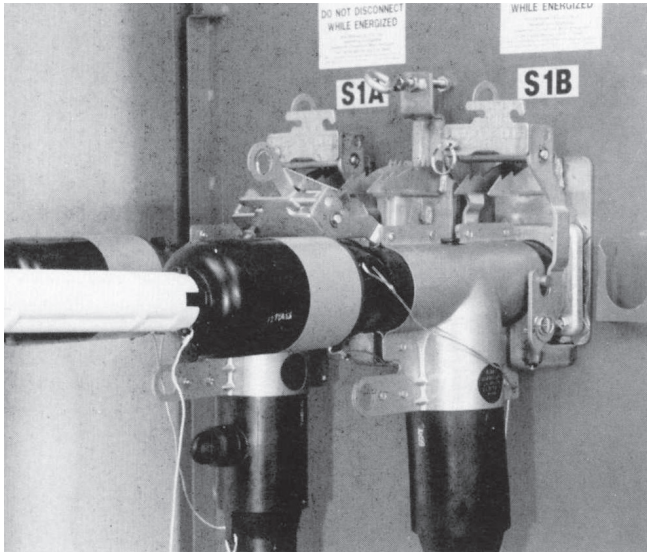

**Figure 22. Place cap on 200 A connector interface.**

Repeat Steps 1 and 2 for all three phases on both ends of cable. Remove all tool, test equipment and personal protective equipment from work area before energizing apparatus.

This page intentionally left blank.

This page intentionally left blank.



**Eaton**  
1000 Eaton Boulevard  
Cleveland, OH 44122  
United States  
Eaton.com

**Eaton's Power Systems Division**  
2300 Badger Drive  
Waukesha, WI 53188  
United States  
Eaton.com/cooperpowerseries

© 2017 Eaton  
All Rights Reserved  
Publication No. MN650011EN  
KA20480492 Rev 01  
(Supersedes KA20480492 Rev 00)

Eaton is a registered trademark.

All trademarks are property  
of their respective owners.

For Eaton's Cooper Power series product  
information call 1-877-277-4636 or visit:  
[www.eaton.com/cooperpowerseries](http://www.eaton.com/cooperpowerseries).