

600 A 35 kV class T-OP™ II deadbreak connector



General

Eaton's Cooper Power™ series 600 A 35 kV Class T-OP™ II deadbreak connector is used to terminate high voltage underground cable to transformers, switches, switchgear and other apparatus. It is fully shielded, submersible and meets the requirements of IEEE Std 386™-2006 standard – Separable Insulated Connector Systems.

The 200 A three-phase rated interface provides a means for obtaining a live test, visible ground, and visible break using a clampstick. It also provides a convenient location for an Eaton's Cooper Power series M.O.V.E. arrester, grounding elbow, or a 200 A tap line.

Eaton's Cooper Power series offers an optional capacitive test point similar to test points on 200 A elbow connectors. This allows use of test point faulted circuit indicators.

T-OP II connectors are designed for use on solid dielectric cable (XLPE or EPR) with extruded semi-conducting shields. Installation on jacketed cable may require additional sealing material. Adapters are available for terminating tape shield and drain wire Unishield® jacketed cable.

EATON

Powering Business Worldwide

Effective October 2015

900 Amp rating

The T-OP II connector system is rated for 900 A continuous when installed on a copper bushing.

200 kV BIL rating

The T-OP II connector is available with an optional 200 kV BIL rating, allowing you to match the BIL rating of the system and the equipment to which it will be connected.

Installation

The T-body is assembled onto prepared cable with a threaded coppertop compression connector. The loadbreak reducing tap plug (LRTP) is threaded into the connector by using a 5/16" T-wrench. The short end of a special copper alloy stud, provided with the kit, is threaded into a de-energized 600 A bushing. The assembled housing is then connected to the apparatus bushing using an O&T/torque tool.

The T-OP II connector's unique captured rotating nut feature provides ease of removal of the T-OP II system from the apparatus bushing. (See Table 5 for information on tools.) Refer to Installation Instruction Sheet S600-52-1 for details.

Production tests

Tests are conducted in accordance with IEEE Std 386™-2006 standard.

- ac 60 Hz 1 Minute Withstand
 - 50 kV/70 kV
- Minimum Partial Discharge Extinction Voltage
 - 26 kV

Tests are conducted in accordance with Eaton requirements.

- Physical Inspection
- Periodic Dissection
- Periodic Fluoroscopic Analysis

Table 1. Voltage Ratings and Characteristics

Description	kV
Standard Voltage Class	35
Maximum Rating Phase-to-Phase (loadbreak reducing tap plug only)	36.6
Maximum Rating Phase-to-Ground	21.1
ac 60 Hz 1 Minute Withstand	
150 kV BIL Class T-OP II	50
200 kV BIL Class T-OP II	70
dc 15 Minute Withstand	103
BIL and Full Wave Crest	150/200
Minimum Partial Discharge Extinction Voltage	26

Voltage ratings and characteristics meet or exceed IEEE Std 386™-2006 standard.

Table 2. Current Ratings and Characteristics

Description	Amperes
600 A Interface	
Continuous	600/900 A rms
24 Hour Overload	1,000 A rms
Short Time	40,000 A rms symmetrical for 0.20 s 27,000 A rms symmetrical for 4.0 s
200 A Interface*	
Continuous	200 A rms
Switching**	10 operations at 200 A rms at 21.1 kV
Fault Closure	10,000 A rms symmetrical at 36.6 kV for 0.17 s
Short time	10,000 A rms symmetrical for 0.17 s 3,500 A rms symmetrical for 3.0 s

Current ratings and characteristics meet or exceed IEEE Std 386™-2006 standard.

* System design and protection must recognize the ratings of 200 A interface.

** Switching rating limited to single-phase 21.1 kV.

Optional features

Protective cap

200 A insulated protective cap fits over loadbreak reducing tap plug for deadfront shielding.

Capacitive test point

Capacitive test point on molded T-body, with snap-on cap, provides a place to mount Eaton's Cooper Power series STVT, STLO and STH faulted circuit indicators.

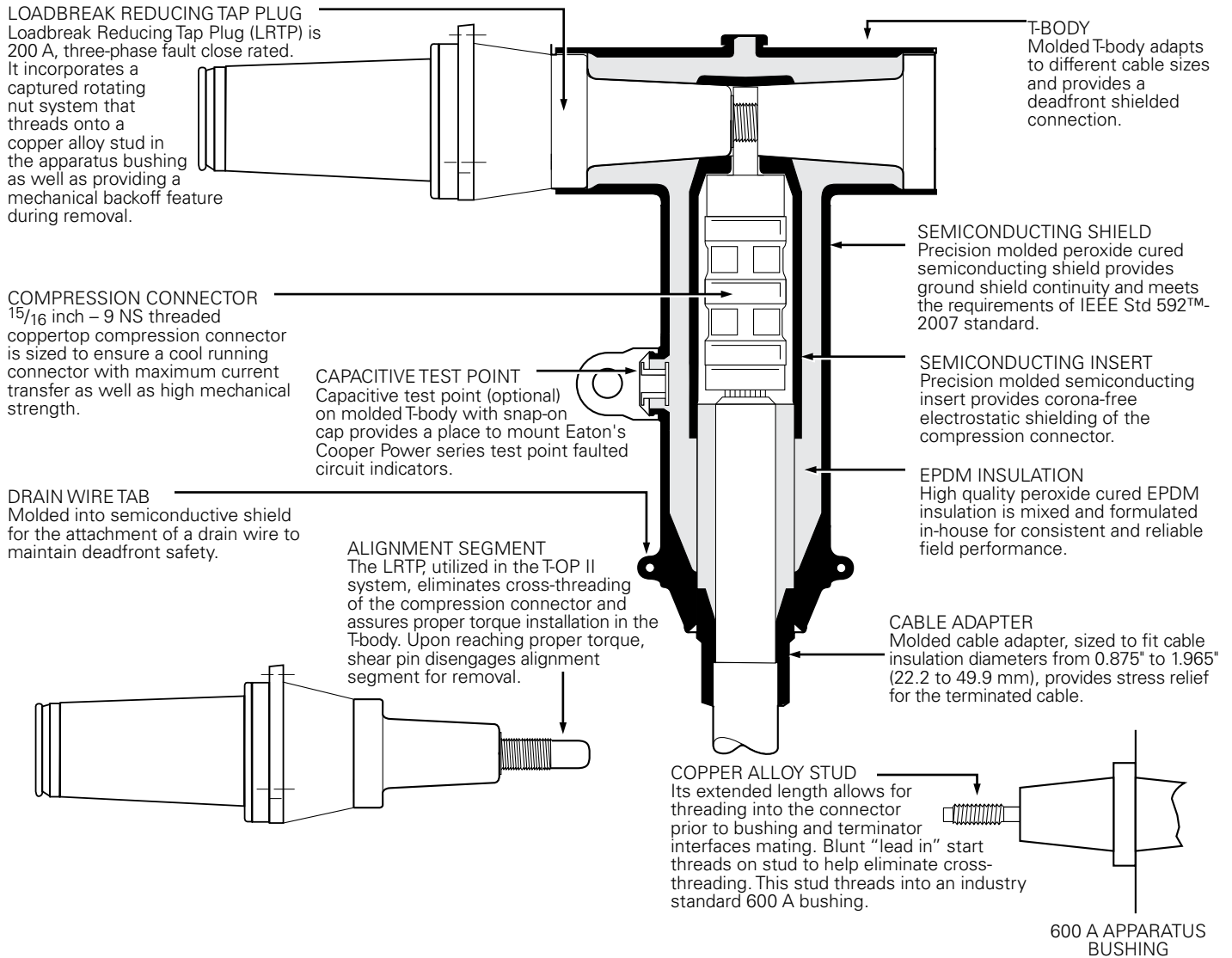

Figure 1. Cutaway drawing illustrates design features.

Note: Dimensions given are for reference only.

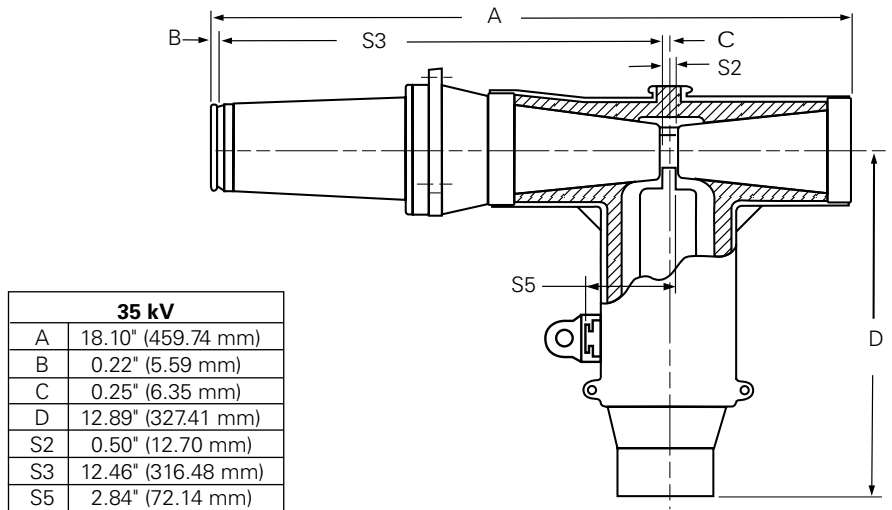

Figure 2. T-OP II connector profile and stacking dimensions.

Note: Dimensions given are for reference only.

Ordering information

Each T-OP II connector kit contains:

- Molded Rubber T-Body
- Loadbreak Reducing Tap Plug
- Cable Adapter
- Coppertop Compression Connector
- Copper Alloy Stud
- Silicone Lubricant
- Installation Instruction Sheet

A 35 kV T-OP II connector is available with or without a protective cap and with or without the test point. Use the following procedure to develop the correct part number for the desired T-OP II connector kit, based on cable size, conductor size and desired options.

Step 1

Select 150 kV BIL or 200 kV BIL version.

150 kV BIL = TP635

200 kV BIL = TP638

Step 2

Determine the cable's diameter over the electrical insulation as shown in Figure 3 (including tolerances). Then identify a cable range from Table 3 that brackets the minimum and maximum insulation diameters. Select the correct Cable Range Code.

Step 3

Identify the conductor size and type in Table 4 and select the Conductor Code from the far right column.

Step 4

For a T-OP II connector kit with a capacitive test point and protective cap, order:



For a T-OP II connector kit without a capacitive test point or protective cap, order:



EXAMPLE: Select a 200 kV BIL T-OP II connector kit without a capacitive test point, with a protective cap for a 4/0 compressed cable with a nominal insulation diameter of 1.26".

Step 1

Kit requires 200 kV BIL bushing interface.

Select "TP638"

Step 2

Nominal diameter over the insulation is 1.26" ± .030"

minimum diameter = 1.26" - .030" = 1.23"

maximum diameter = 1.26" + .030" = 1.29"

From Table 3 identify the cable range 1.23" - 1.29" and select the "J" or "K" Cable Range Code.

Step 3

The conductor size is a 4/0 compressed. From Table 4, under the column "Concentric or Compressed," identify 4/0 and select the "16" conductor code.

Step 4

Order catalog number: TP638J16C.

To order replacement compression connectors and cable adapters for a T-OP II Connector System, see catalog section CA650006EN "Deadbreak Accessories, Tools, and Replacement Parts."

Table 3. Cable Diameter Range

Inches	mm	Cable Range Code	Inches	mm	Cable Range Code
0.875-0.985	22.2-25.0	D	1.355-1.520	34.4-38.6	M
0.930-1.040	23.6-26.4	E	1.485-1.595	37.7-40.5	N
0.980-1.115	24.9-28.3	F	1.530-1.640	38.9-41.7	P
1.040-1.175	26.4-29.8	G	1.575-1.685	40.0-42.8	Q
1.095-1.240	27.8-31.5	H	1.665-1.785	42.3-45.3	R
1.160-1.305	29.5-33.1	J	1.755-1.875	44.6-47.6	S
1.220-1.375	31.0-34.9	K	1.845-1.965	46.9-49.9	T
1.285-1.395	32.6-35.4	L	1.960-2.210	49.8-56.1	U

Table 4. Conductor Size and Type

Concentric or Compressed	Compact or Solid		Conductor Code	
	AWG or kcmil	mm ²		AWG or kcmil
No Connector				00
3	—	2	—	10
2	—	1	—	11
1	—	1/0	—	12
1/0	50	2/0	70	13
2/0	70	3/0	—	14
3/0	—	4/0	95	15
4/0	95	250	120	16
250	120	300	—	17
300	150	350	—	18
350	—	400	185	19
400	185	450	—	20
450	—	500 ^a	240	21
500	240	600	300	22
600	300	700	—	23
650 ^b	—	750 ^c	—	24
750 ^d	400	900	—	25
900	—	1000	500	26
1000	500	—	—	27
1250	630	—	—	28

^a Also accepts 550 kcmil compact conductor.

^c Also accepts 800 kcmil compact conductor.

^b Also accepts 700 kcmil compressed conductor.

^d Also accepts 700 kcmil concentric conductor.

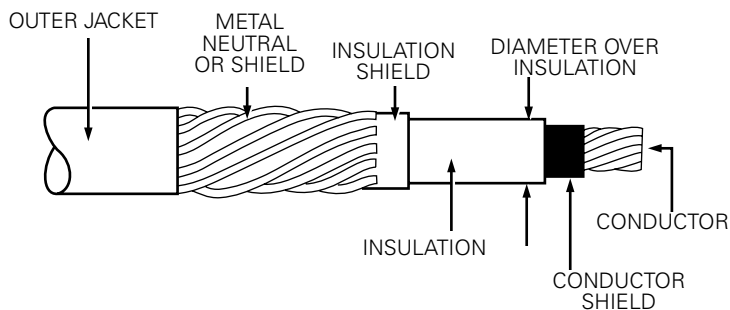

Figure 3. Illustration showing typical construction of medium voltage underground cable.

Table 5. Replacement Parts and Tools

Description	Catalog Number	
	150 kV BIL	200 kV BIL
T-body without Test Point	DT635	DT638
T-body with Test Point	DT635T	DT638T
Loadbreak Reducing Tap Plug (LRTP)	LRTP635	LRTP638
Operating and Test/Torque Tool with Cap	OTTQ635	OTTQ635
Installation Torque Tool	TQHD635	TQHD635
5/16" T-Wrench	TWRENCH	TWRENCH
Copper Alloy Stud for use w/T-OP II	STUD-T	STUD-T
200 A, 35 kV Class Insulated Protective Cap	LPC235	LPC238
15/16" Threaded Coppertop Connector	CC6C**T	CC6C**T
Cable Adapters	CA635*	CA638*
5/16" Hex Shaft with 3/8" Drive Socket	HD635	HD635
Operating and Test Tool with Cap	OT635	OT635

* Use Table 3 to select cable range code. ** Use Table 4 for conductor code.



Figure 4. Catalog Number TWRENCH

The T-Wrench is used to install the loadbreak reducing tap plug into the compression connector and T-body.



Figure 5. Catalog Number TQHD635

The Torque Tool is required to check the torque of a 35 kV Class T-OP II deadbreak connector or bushing adapter when it is installed on a 600 A bushing interface. It is precision calibrated and hotstick operable.



Figure 6. Catalog Number OTTQ635

The combination Operating and Test/Torque Tool is used with a hotstick to test for circuit de-energization and to install and remove a 35 kV Class LRTP equipped connector from an apparatus tap. The standard tool is equipped with a molded EPDM rubber cap and torque limiter to allow proper tool seating and gripping of the T-OP II connector. It also ensures that the connector has been properly torqued into the mating bushing.

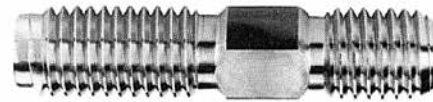

Figure 7. Catalog Number STUD-T

The Copper Alloy Stud with its extended length allows for threading into the connector prior to mating the bushing and terminator interfaces. Blunt start threads on the stud help eliminate cross-threading. Stud threads into an industry standard 600 A bushing.

Eaton
1000 Eaton Boulevard
Cleveland, OH 44122
United States
Eaton.com

Eaton's Cooper Power Systems Division
2300 Badger Drive
Waukesha, WI 53188
United States
Eaton.com/cooperpowerseries

© 2015 Eaton
All Rights Reserved
Printed in USA
Publication No. CA650055EN

Eaton is a registered trademark.
All other trademarks are property
of their respective owners.

For Eaton's Cooper Power series product
information call 1-877-277-4636 or visit:
www.eaton.com/cooperpowerseries.