

600 A 35 kV Class T-OP II connector assembly installation instructions

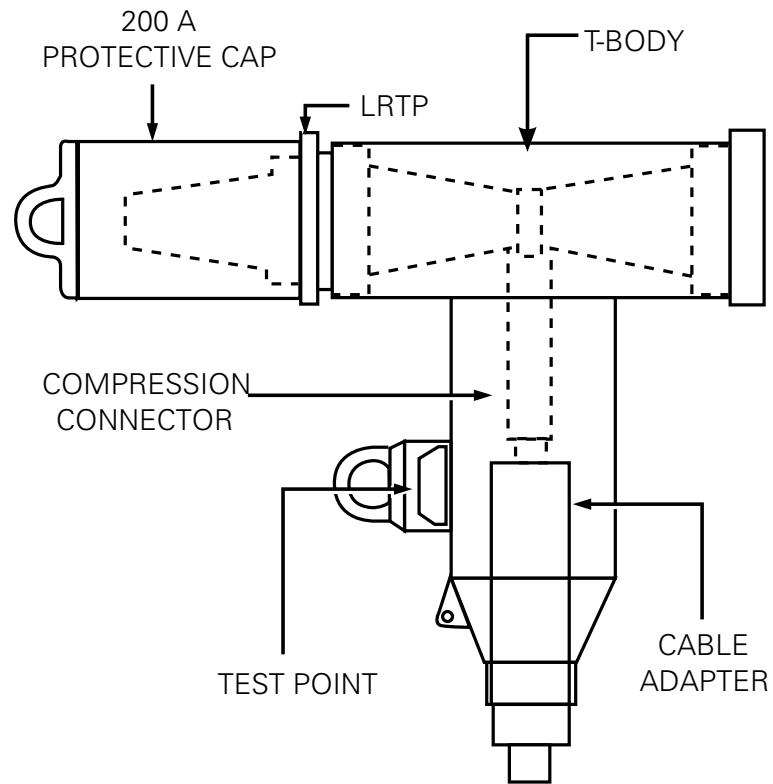

DISCLAIMER OF WARRANTIES AND LIMITATION OF LIABILITY

The information, recommendations, descriptions and safety notations in this document are based on Eaton Corporation's ("Eaton") experience and judgment and may not cover all contingencies. If further information is required, an Eaton sales office should be consulted. Sale of the product shown in this literature is subject to the terms and conditions outlined in appropriate Eaton selling policies or other contractual agreement between Eaton and the purchaser.

THERE ARE NO UNDERSTANDINGS, AGREEMENTS, WARRANTIES, EXPRESSED OR IMPLIED, INCLUDING WARRANTIES OF FITNESS FOR A PARTICULAR PURPOSE OR MERCHANTABILITY, OTHER THAN THOSE SPECIFICALLY SET OUT IN ANY EXISTING CONTRACT BETWEEN THE PARTIES. ANY SUCH CONTRACT STATES THE ENTIRE OBLIGATION OF EATON. THE CONTENTS OF THIS DOCUMENT SHALL NOT BECOME PART OF OR MODIFY ANY CONTRACT BETWEEN THE PARTIES.

In no event will Eaton be responsible to the purchaser or user in contract, in tort (including negligence), strict liability or otherwise for any special, indirect, incidental or consequential damage or loss whatsoever, including but not limited to damage or loss of use of equipment, plant or power system, cost of capital, loss of power, additional expenses in the use of existing power facilities, or claims against the purchaser or user by its customers resulting from the use of the information, recommendations and descriptions contained herein. The information contained in this manual is subject to change without notice.

Contents

- DISCLAIMER OF WARRANTIES AND LIMITATION OF LIABILITY I**
- SAFETY FOR LIFE III**
- SAFETY INFORMATION III**
 - Safety instructions iii
- PRODUCT INFORMATION 1**
 - Introduction 1
 - Read this manual first 1
 - Additional information 1
 - Acceptance and initial inspection 1
 - Handling and storage 1
 - Standards 1
- INSTALLATION PROCEDURE 1**
 - Equipment required 1
 - Prepare the cable 2
 - Install T-body and reducing tap plug 4
 - Install T-OP II connector onto apparatus bushing 5



Safety for life



Eaton's Cooper Power series products meet or exceed all applicable industry standards relating to product safety. We actively promote safe practices in the use and maintenance of our products through our service literature, instructional training programs, and the continuous efforts of all Eaton employees involved in product design, manufacture, marketing and service.

We strongly urge that you always follow all locally approved safety procedures and safety instructions when working around high-voltage lines and equipment and support our "Safety For Life" mission.

Safety information

The instructions in this manual are not intended as a substitute for proper training or adequate experience in the safe operation of the equipment described. Only competent technicians who are familiar with this equipment should install, operate, and service it.

A competent technician has these qualifications:

- Is thoroughly familiar with these instructions.
- Is trained in industry-accepted high- and low-voltage safe operating practices and procedures.
- Is trained and authorized to energize, de-energize, clear, and ground power distribution equipment.
- Is trained in the care and use of protective equipment such as flash clothing, safety glasses, face shield, hard hat, rubber gloves, hotstick, etc.

Following is important safety information. For safe installation and operation of this equipment, be sure to read and understand all cautions and warnings.

Hazard Statement Definitions

This manual may contain four types of hazard statements:

DANGER

Indicates a hazardous situation which, if not avoided, will result in death or serious injury.

WARNING

Indicates a hazardous situation which, if not avoided, could result in death or serious injury.

CAUTION

Indicates a hazardous situation which, if not avoided, could result in minor or moderate injury.

CAUTION

Indicates a hazardous situation which, if not avoided, could result in equipment damage only.

Safety instructions

Following are general caution and warning statements that apply to this equipment. Additional statements, related to specific tasks and procedures, are located throughout the manual.

DANGER

Hazardous voltage. Contact with hazardous voltage will cause death or severe personal injury. Follow all locally approved safety procedures when working around high- and low-voltage lines and equipment.

G103.3

WARNING

Before installing, operating, maintaining, or testing this equipment, carefully read and understand the contents of this manual. Improper operation, handling or maintenance can result in death, severe personal injury, and equipment damage.

G101.0

WARNING

This equipment is not intended to protect human life. Follow all locally approved procedures and safety practices when installing or operating this equipment. Failure to comply may result in death, severe personal injury and equipment damage.

G102.1

WARNING

Power distribution and transmission equipment must be properly selected for the intended application. It must be installed and serviced by competent personnel who have been trained and understand proper safety procedures. These instructions are written for such personnel and are not a substitute for adequate training and experience in safety procedures. Failure to properly select, install or maintain power distribution and transmission equipment can result in death, severe personal injury, and equipment damage.

G122.3

⚠ DANGER

Hazardous voltage. Contact with high voltage will cause death or severe personal injury. All associated apparatus must be de-energized during any hands-on installation or maintenance.

⚠ WARNING

Capacitive Test Point Operating Warning. Misuse of capacitive test points can result in death, severe personal injury, and equipment damage. Use only voltage indicating instruments specifically designed for test points. Use of conventional voltage sensing devices may provide false “No Voltage” indications.

The test point must be dry and free of contaminant’s when checking for voltage. After indication is taken: clean, dry, and lubricate the test point cap with silicone grease and assemble to the test point.

The capacitive test point is not sufficiently accurate, nor is it intended for, actual voltage measurements or phasing operations.

A reading of no voltage from the test point should not be the only indication of a de-energized circuit obtained before touching the connector. Other procedures can include direct conductor voltage testing or grounding using a live-line tool.

⚠ WARNING

Hazardous Voltage

- Failure to comply may result in death, severe personal injury and equipment damage.
- Follow all locally approved procedures when installing or operating this equipment.
- The 600 A T-OP II Connector System is designed to be operated in accordance with normal safe operating procedures.
- These instructions are not intended to supersede or replace existing safety and operating procedures.
- The elbow connector should be installed and serviced only by personnel familiar with good safety practices and the handling of high-voltage electrical equipment.

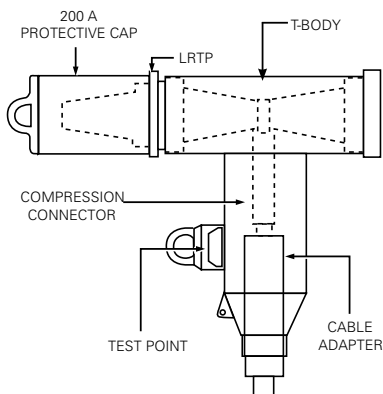

Figure 1. Line illustration of typical 35 kV T-OP II connector assembly

Product information

Introduction

The Eaton Cooper Power series 600 A, 35 kV Class T-OP II Deadbreak Connectors are used to terminate high voltage underground cables to deadfront apparatus such as transformers, switches, and switchgear. They are fully shielded, submersible, and meet the requirements of IEEE Std 386™ standard – Separable Insulated Connector Systems.

Read this manual first

Read and understand the contents of this manual and follow all locally approved procedures and safety practices before installing or operating this equipment.

Additional information

These instructions cannot cover all details or variations in the equipment, procedures, or process described nor provide directions for meeting every possible contingency during installation, operation, or maintenance. For additional information, contact your representative.

Acceptance and initial inspection

Each deadbreak connector is in good condition when accepted by the carrier for shipment. Upon receipt, inspect the shipping container for signs of damage. Unpack the deadbreak connector and inspect it thoroughly for damage incurred during shipment. If damage is discovered, file a claim with the carrier immediately.

Handling and storage

Be careful during handling and storage of the deadbreak connector to minimize the possibility of damage. If the deadbreak connector is to be stored for any length of time prior to installation, provide a clean, dry storage area.

Standards

ISO 9001 Certified Quality Management System

Installation procedure

Equipment required

- T-OP II connector assembly kit including
 - T-Body
 - Cable Adapter
 - Copper Top Compression Connector
 - Loadbreak Reducing Tap Plug (LRTP) with alignment segment
 - Protective Cap (when furnished)
 - Silicone Lubricant
 - Extended Copper Stud
 - Instruction Sheet

- Tools
 - 1/2" Wrench
 - Torque Tool (Catalog Number TQHD635)
 - 5/16" T-Wrench (Catalog Number TWRENCH)
 - O & T Tool (Catalog Number OT635)
 - Combined O & T/Torque Tool (Catalog Number OTTO635)

Note: If a Combined O & T/Torque Tool is used, a separate O & T tool and torque wrench is not required.

Prepare the cable

Note: If concentric neutral cable is not being used, follow cable preparation directions in shield adapter kit.

Step 1

Train cable

- Position cable vertically so that it is centered between apparatus bushing and parking pocket, parallel to, and 7" (178 mm) from apparatus frontplate.
- Provide adequate cable slack for cable movement between standoff bushing and apparatus bushing.
- Support cable as needed to maintain position.
- Cut cable 1 3/4" (45 mm) from centerline of bushing. (Refer to Figure 2.)

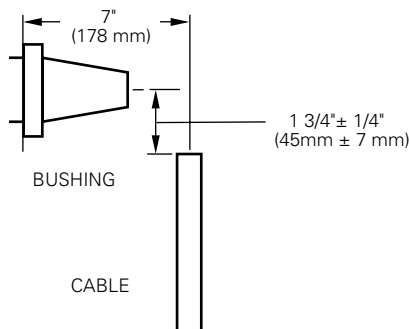

Figure 2. Line illustration for cable training

Step 2

Remove concentric neutral wires or jacket

Note: Care should be taken to not cut or score the neutral conductors when cutting the cable jacket.

- Measure 13" (330 mm) from end of cable. (Refer to Figure 3.)
 - If jacketed neutral cable, remove jacket to 13" dimension.
 - If unjacketed neutral cable, bind neutral wires using (3) wraps of tape at 14 3/4" dimension.

- Pull back concentric neutral wires. Allow enough extra concentric neutral wires to connect to ground after installation and allow movement to insulated standoff bushing.

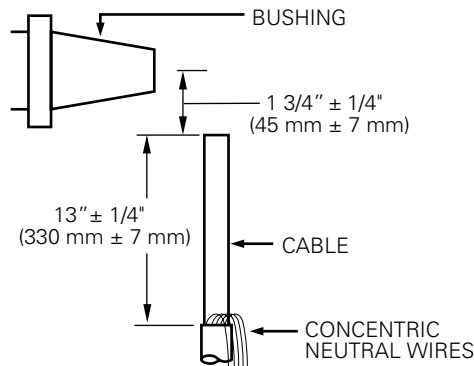

Figure 3. Line illustration of removing concentric neutral wires

Step 3

Remove insulation shield.

- Remove insulation shield 10 1/2" (267 mm) from end of cable. (Refer to Figure 4.)

Note: Do not cut or nick insulation.

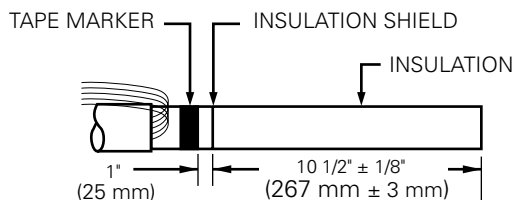

Figure 4. Line illustration of cable stripback

Step 4

Put tape marker in place

- Measure 1" (25 mm) from end of insulation shield. (Refer to Figure 4.)
- Wrap two turns of tape to serve as marker for cable adapter location.

Step 5

Remove conductor insulation

Note: Do not pencil cable.

- Remove insulation exposing bare conductor to length of 4 3/8" (111 mm). (Refer to Figure 5.)

Note: Do not unwind conductor strands.

600 A 35 kV Class T-OP II connector assembly installation instructions

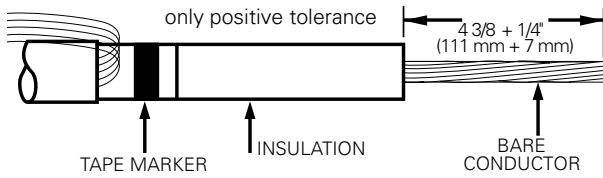

Figure 5. Line illustration of bare conductor length

Step 6

Bevel insulation

Note: This step is for ease of installation only and has no effect on electrical characteristics.

- Remove sharp edge of insulation by beveling at 45° angle for approximately 1/4" (6 mm). (See Figure 6.)

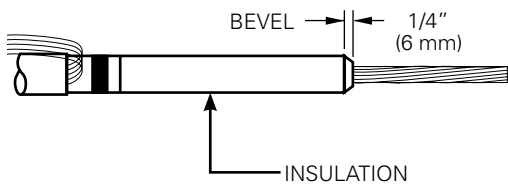

Figure 6. Line illustration of insulation bevel

Step 7

Clean insulation

Note: Do not apply solvent directly to cable.

- Clean insulation thoroughly with solvent dampened rag, wiping from conductor end toward insulation shield. (Refer to Figure 7.)
- Ensure that all traces of conductive residue are removed.

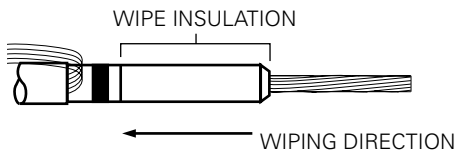

Figure 7. Line illustration of insulation cleaning

Step 8

Lubricate and install cable adapter

- Lubricate exposed cable insulation.
- Lubricate inside of cable adapter.
- Slide small end of cable adapter over cable using twisting motion until small end is flush with tape marker. (Refer to Figure 8.)

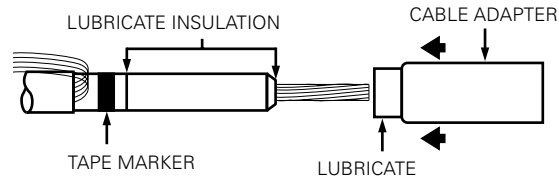

Figure 8. Line illustration of insulation cable adapter

- After sliding the cable adapter into position make sure that no bulge is present (see Figure 9).

WARNING

Equipment Damage/Personal Injury. Improperly positioned cable adapter may result in equipment damage or personal injury.

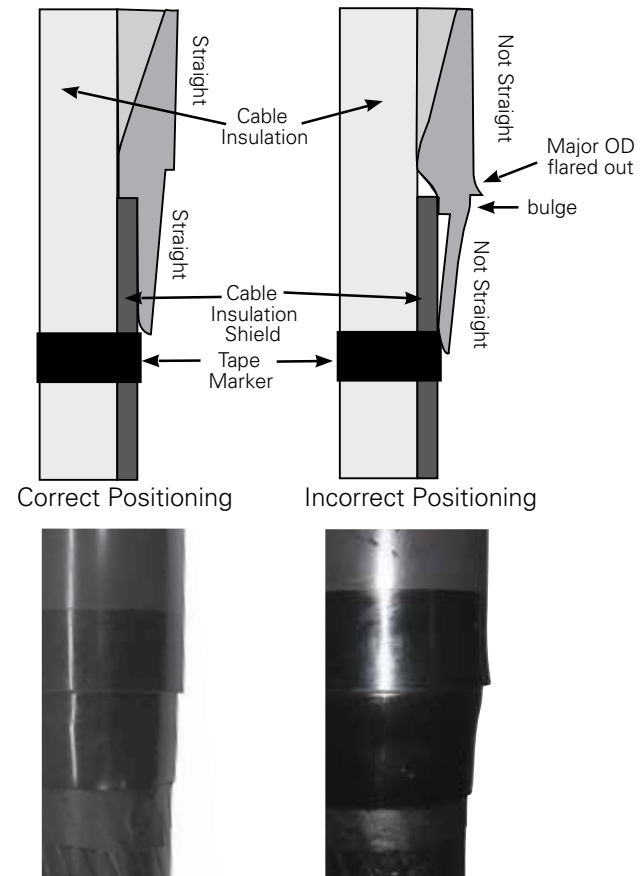

Figure 9. Cross sectional view of cable adapter positioning

Step 9

Install compression connector

Note: Refer to chart supplied with the crimp connector for tool and die to be used.

- Wire brush conductor, only if it is aluminum.
- Remove protective cap from compression connector.
- Insert conductor completely into compression connector and rotate connector to distribute inhibitor.

Note: Connector must be fully seated on cable conductor.

- Align flats of compression connector and apparatus bushing for minimum conductor strain.
- Make first crimp 1/2" (13 mm) below shoulder of compression connector. (Refer to Figure 10.)

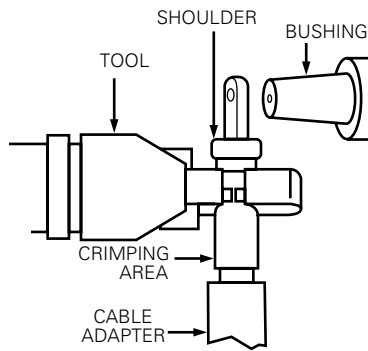

Figure 10. Line illustration of crimping area

- Rotate each successive crimp 90° on compression connector and allow 1/8" (3 mm) between crimps.
- Wipe excess inhibitor from connector and adapter surfaces.

Step 10

Check dimensions

- Check length from end of compression connector to top of cable adapter.
- Length should be between 6 3/4" and 7 3/4" (171-197 mm). (Refer to Figure 11.)

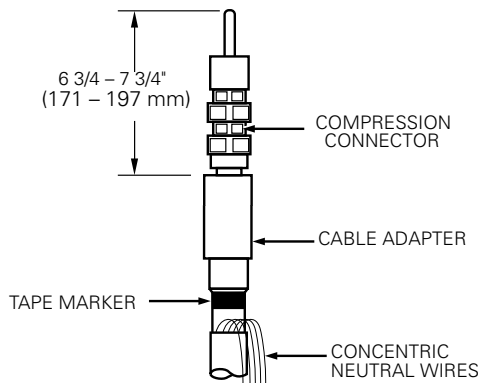

Figure 11. Line illustration for dimensional check

Install T-body and reducing tap plug

Step 11

Install T-body

- Clean and lubricate outside of cable adapter with lubricant supplied.
- Clean and lubricate inside of T-Body with lubricant supplied.

Note: If test point T-Body is used, insure test point is opposite front plate side of T-Body.

- Without moving the cable adapter, slide T-Body onto cable adapter until compression connector eye is centered in 600 A interfaces. (Refer to Figure 12.)

Note: The end of the cable adapter must line up with the top edge of the tape marker after T-body assembly. Refer to Figure 9.

- Remove tape marker from cable.

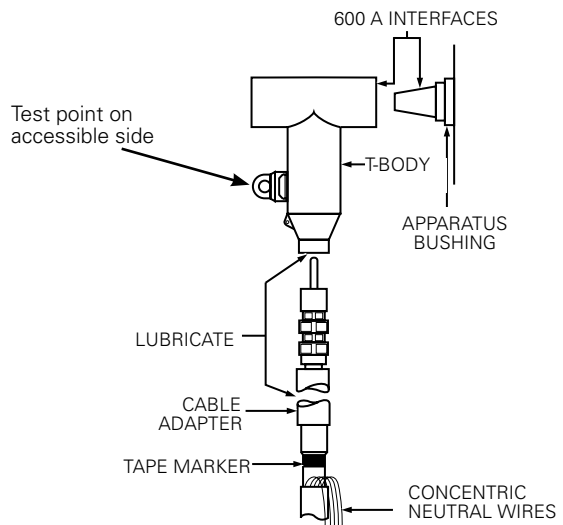

Figure 12. Line illustration of BOL-T-body installation

Step 12.

Install loadbreak reducing tap plug (LRTP) into t-Body

- Clean and then lubricate mating 600 A interface of the LRTP and T-Body with lubricant supplied or CPS approved equivalent.
- Check that compression connector flats are parallel to apparatus bushing.
- Remove shipping cap from 200 A LRTP interface and thread protector from 15/16" threads.
- Insert T-Wrench into throat of LRTP and through rotating nut and engage alignment segment. (T-Wrench will not rotate without entire LRTP rotating.)
- Insert threaded ferrule end of LRTP into side of T-Body opposite apparatus bushing. (Refer to Figure 13.)

600 A 35 kV Class T-OP II connector assembly installation instructions

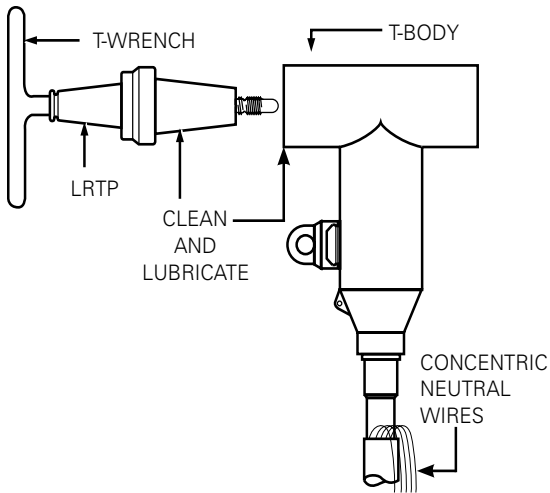

Figure 13. Line illustration of L RTP installation

- Carefully thread alignment segment into threads of the compression connector by turning the T-Wrench clockwise until positive stop is felt
- Continue applying clockwise force to the T-Wrench until the pin shears and the T-Wrench and alignment segment rotate freely.
- Remove the alignment segment by applying pressure to the T-Wrench to separate the alignment segment from the L RTP. Discard the alignment segment.
- See Figure 14 for illustration of completed L RTP installation.

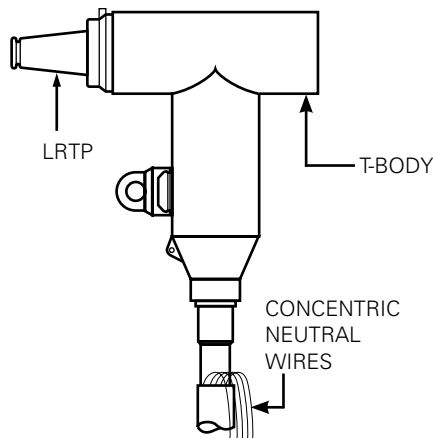

Figure 14. Line illustration of completed L RTP installation T-OP II T-body

Install T-OP II connector onto apparatus bushing

Step 13

Install stud into apparatus bushing

Note: Ensure unit is de-energized.

- Thread the shorter threaded end of T-OP II stud into the apparatus bushing until hand tight. (Refer to Figure 15.)
- Engage the flats of the stud with a 1/2 wrench and thread the stud into the bushing an additional 1/4 revolution past hand tight.
- Remove any shavings that may have been raised during the threading procedure.

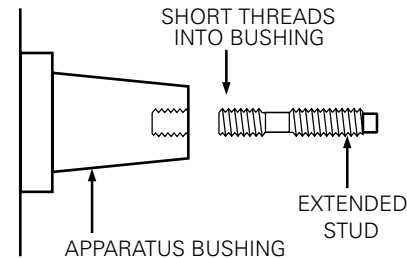

Figure 15. Line illustration of bushing stud installation

Step 14

Install t-op II body on apparatus bushing

Note: T-OP II T-Body can be installed onto the apparatus bushing using either a separate operating and testing (O & T) tool and torque tool (refer to option A) or using a combined O & T/Torque Tool (option B).

Option A - Installing T-OP II T-Body on apparatus bushing using a separate O& T Tool and torque tool

- Clean and lubricate mating interfaces of apparatus bushing and T-Body with lubricant supplied.
- Grasp eye of the O & T tool with a hotstick, pull eye fully into hotstick.
- Using hotstick, insert O & T tool into L RTP throat and engage rotating nut. (Refer to Figure 16.)
- While pushing T-Body onto apparatus bushing, turn O & T tool clockwise to make threaded connection. Turn until tight.
- Remove O & T tool from the L RTP.
- Insert the torque tool. Torque until tool ratchets (20-25 ft.-lbs.).
- Remove the torque tool.

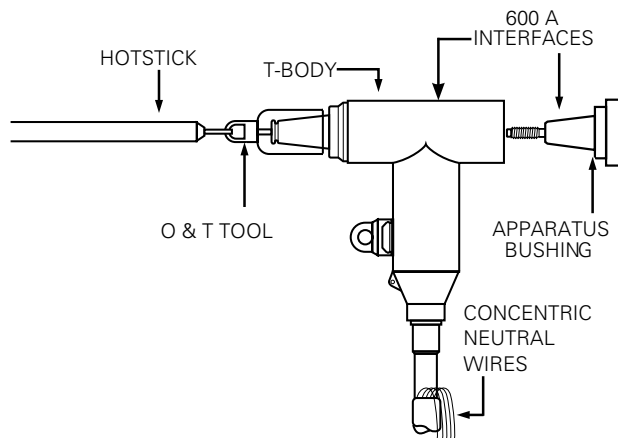

Figure 16. Line illustration of installing T-OP II T-body onto apparatus bushing

Option B - Installing t-OP II T-body on apparatus bushing using a combined O & T/Torque tool

- Clean and lubricate mating interfaces of apparatus bushing and T-Body with lubricant supplied.
- Grasp eye of the O & T/Torque tool with a hotstick, pull eye fully into hotstick.
- Using a hotstick, insert the O & T/Torque tool into the L RTP throat and engage the rotating nut.
- While pushing the T-Body onto the apparatus bushing, turn O & T/Torque tool clockwise to make the threaded connection, turn until torque head ratchets (20-25 ft.-lbs.). An audible click will be heard.
- Remove the O & T/Torque tool.

Step 15

Cap the 200 a interface

- Clean and lubricate the 200 A interface of the L RTP and mating apparatus (i.e., Protective Cap, Grounding Elbow or M.O.V.E. Arrester) with lubricant supplied. (Refer to Figure 17.)
- To cap interface, follow installation instructions supplied with apparatus used.

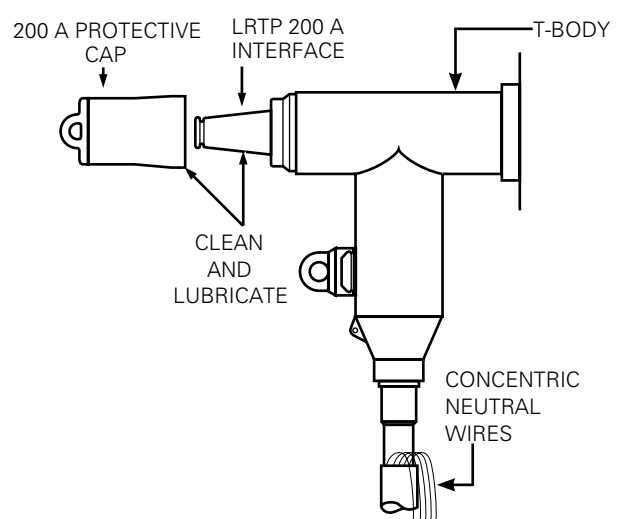

Figure 17. Line illustration of protective cap installation

Step 16

Ground system

- Connect tie-off tabs of the L RTP and T-Body with a strand of drain wire to the cable concentric neutral wires and/or to common ground point.
- Connect the 200 A apparatus (i.e., Protective Cap, Grounding Elbow, M.O.V.E. Arrester) drain wire to common ground.
- Connect concentric neutral wires to the common ground point leaving adequate slack for hotstick operation. (Refer to Figure 18.)

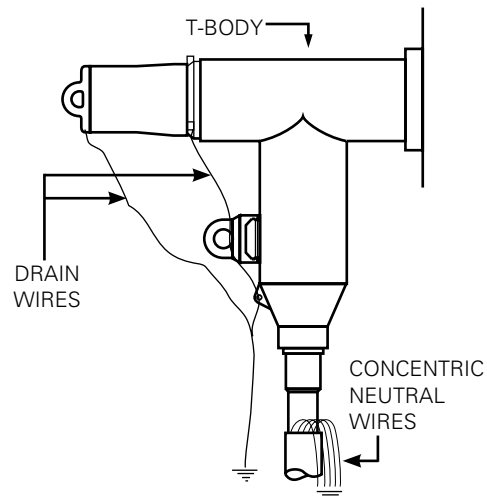

Figure 18. Line illustration of grounding

This page intentionally left blank.



Eaton
1000 Eaton Boulevard
Cleveland, OH 44122
United States
Eaton.com

Eaton's Power Systems Division
2300 Badger Drive
Waukesha, WI 53188
United States
Eaton.com/cooperpowerseries

EAT•N
Powering Business Worldwide

© 2017 Eaton
All Rights Reserved
Printed in USA
Publication No. MN650051EN
May 2017

Eaton is a registered trademark.

All trademarks are property
of their respective owners.

For Eaton's Cooper Power series product
information
call 1-877-277-4636 or visit:
www.eaton.com/cooperpowerseries.