

600 A 35 kV class PUSH-OP™ insulated standoff bushing

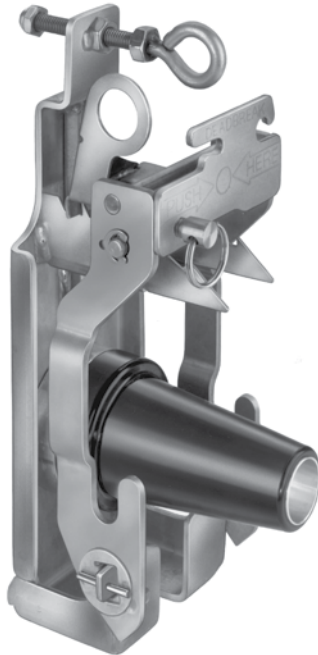

General

Eaton meets the full requirements of IEEE Std 386™-2006 standard – Separable Insulated Connector Systems in its Cooper Power™ series 600 A, 35 kV PUSH-OP™ insulated standoff bushing providing a single deadbreak interface made of high quality insulating epoxy material.

It is used in switchgear, transformers, and other apparatus to isolate and sectionalize an energized cable. Temporary or permanent parking of energized 600 A 35 kV PUSH-OP deadbreak connectors is simplified with the use of an insulated standoff bushing.

The PUSH-OP insulated standoff bushing is designed to be installed in the parking stand mounted on switchgear, transformers, or other apparatus. A drain wire lug is provided on the standoff bracket for attachment of a drain wire to ensure deadfront construction. The bushing provides a fully shielded, submersible connection for deadbreak operation.

All standoff bushing brackets have a stainless steel eyebolt with a brass pressure foot. The bushing body is bolted to a stainless steel base bracket using a stainless steel bolt. The bracket and latch mechanism provides easy installation of a PUSH-OP connector without any threading operations. Optional hitch pin locks the latch mechanism in place for added security.

Installation

A clampstick tool is used to place the standoff bushing in the parking stand on the front plate of the apparatus. The PUSH-OP connector is then installed onto the standoff bushing tap. Refer to *Service Information S600-65-1 600 A 15/25 and 35 kV Class PUSH-OP Insulated Standoff Bushing Installation Instructions* for complete installation details on the PUSH-OP insulated standoff bushing.

EATON

Powering Business Worldwide

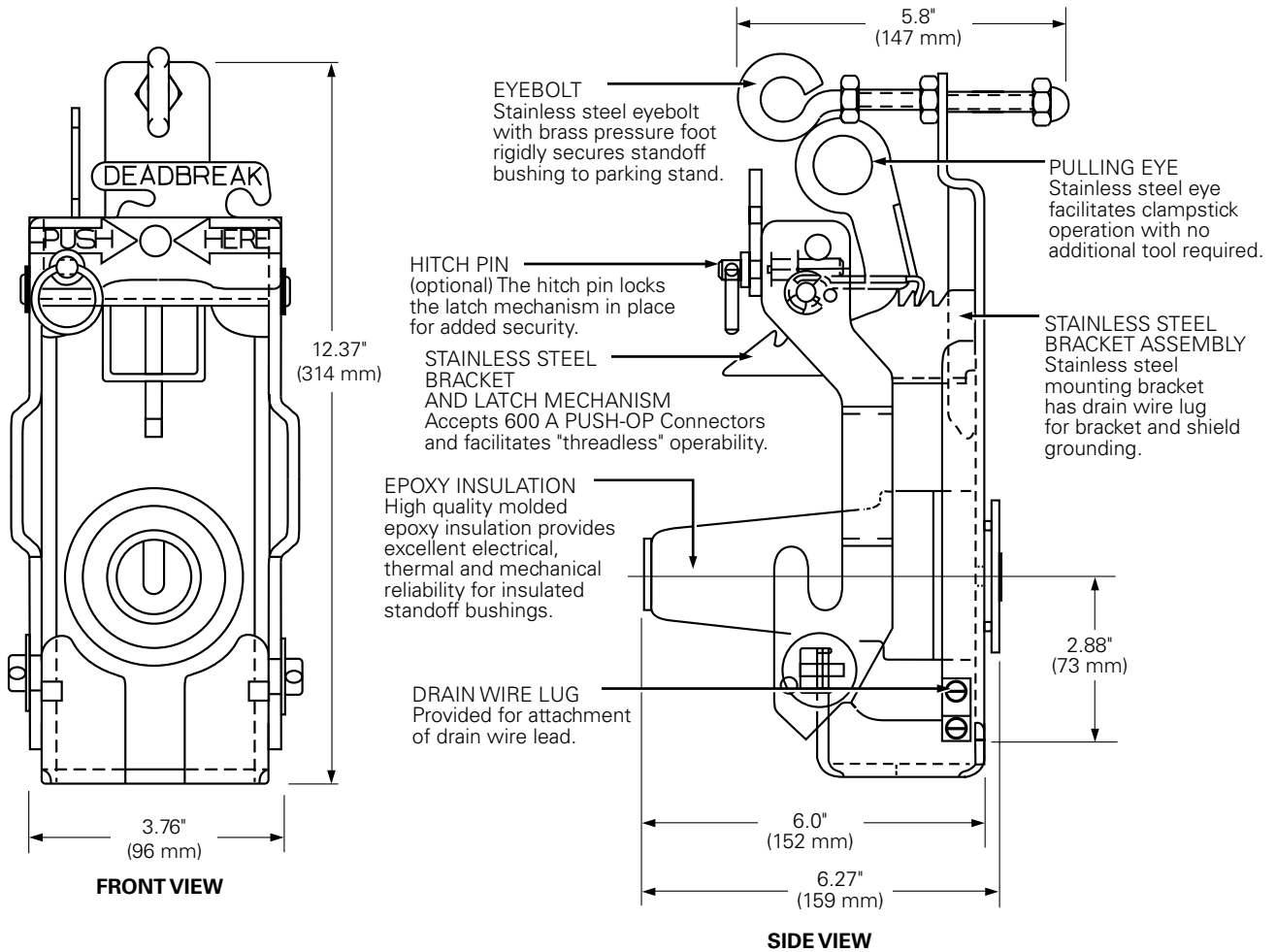

Figure 1. Front view shows standoff bushing and latch mechanism. Side view shows standoff bushing and latch mechanism with bracket assembly.

Note: Dimensions given are for reference only.

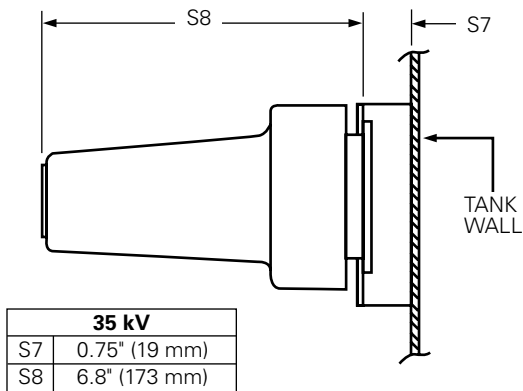

Figure 2. PUSH-OP stacking dimensions.

Production tests

Tests conducted in accordance with IEEE Std 386™-2006 standard:

- ac 60 Hz 1 Minute Withstand
 - 50 kV
- Minimum Corona Voltage Level
 - 26 kV

Tests conducted in accordance with Eaton requirements:

- Physical Inspection
- Periodic Fluoroscopic Analysis

Table 1. Voltage Ratings and Characteristics – Insulated Standoff Bushing

Description	kV
Standard Voltage Class	35
Maximum Rating Phase-to-Ground	21.1
ac 60 Hz 1 Minute Withstand	50
dc 15 Minute Withstand	103
BIL and Full Wave Crest	150
Minimum Corona Voltage Level	26

Voltage ratings and characteristics are in accordance with IEEE Std 386™-2006 standard.

Ordering information

To order a 35 kV Class Standoff Bushing Kit for PUSH-OP refer to Table 2.

Table 2. Standoff Bushing Kit

Description	Catalog Number
Insulated Standoff Bushing	PISB635
Insulated Standoff Bushing with hitch pin	PISB635HP

Each kit contains:

- Standoff Bushing with Bracket
- Shipping Cap (not for energized operation)
- Silicone Lubricant
- Installation Instruction Sheet

Eaton
1000 Eaton Boulevard
Cleveland, OH 44122
United States
Eaton.com

Eaton's Cooper Power Systems Division
2300 Badger Drive
Waukesha, WI 53188
United States
Eaton.com/cooperpowerseries

© 2015 Eaton
All Rights Reserved
Printed in USA
Publication No. CA650049EN

Eaton, Cooper Power, and PUSH-OP are valuable trademarks of Eaton in the U.S. and other countries. You are not permitted to use these trademarks without the prior written consent of Eaton.

IEEE Std 386™-2006 standard is a trademark of the Institute of Electrical and Electronics Engineers, Inc., (IEEE). This publication is not endorsed or approved by the IEEE.

For Eaton's Cooper Power series PUSH-OP bushing product information call 1-877-277-4636 or visit: www.eaton.com/cooperpowerseries.