

600 A 35 kV class BOL-T™ deadbreak connector



General

Eaton terminates high-voltage underground cables to deadfront apparatus such as transformers, switches and switchgear with its Cooper Power series 600 A, 35 kV Class BOL-T™ deadbreak connector. It is fully shielded, submersible, and meets the requirements of IEEE Std 386™-2016 standard— Separable Insulated Connector Systems.

The capacitive test point on the insulating plug provides a means of testing the circuit without disturbing the bolted connection.

In addition to the capacitive test point feature on the insulating plug, Eaton offers an optional capacitive test point similar to the test points on its Cooper Power series 200 A elbows. This allows the use of the Type “TPR” faulted circuit indicators, and provides a hotstick operable means of determining circuit condition when used with high impedance voltage sensing devices designed for test points.

BOL-T connectors are designed for use on solid dielectric cable (XLPE or EPR) with extruded semiconductive shields and concentric neutral, with or without a jacket.

Installation on jacketed concentric neutral cable may require additional sealing material. A special grounding adapter is available for tape shield, linear corrugated, unshield, and drain wire cables for use with deadbreak connectors.

EAT•N

Powering Business Worldwide

900 Amp rating

The BOL-T connector is rated for 900 A continuous when used with a coppertop compression connector or shear bolt, copper insulating plug, copper stud and copper bushing or junction. If a 900 A rating is desired, specify a "C" as the 9th digit when determining your part number. See Step 3, page 4.

200 kV BIL rating

The BOL-T connector is available with an optional 200 kV BIL rating, allowing you to match the BIL rating of the system and the equipment to which it will be connected. If 200 kV BIL rating is required, specify "38" in digits 4 and 5 in the part number. See page 4.

Interchangeability

Eaton conforms to the electrical, mechanical and dimensional requirements of IEEE Std 386™-2016 standard with its Cooper Power series 600 A deadbreak connectors. The connectors can be used on any comparably rated bushing interface that also meets the requirements of this standard. In addition, all cable adapters, insulating plugs and compression connectors are designed to be interchangeable with those currently available from other major manufacturers that also certify their components to IEEE Std 386™-2016 standard.

Installation

A torque wrench and one-inch socket are used to tighten the insulating plug through the compression or shear bolt connector within the T-Body onto a de-energized 600 A bushing interface. Refer to *Service Information MN650002EN 600 A 35 kV Class BOL-T Connector Assembly Installation Instructions* for details.

Production tests

Tests are conducted in accordance with IEEE Std 386™-2016 standard.

- ac 60 Hz 1 Minute Withstand
 - 50 kV/70 kV
- Minimum Partial Discharge Extinction Voltage
 - 26 kV

Tests are conducted in accordance with Eaton requirements.

- Physical Inspection
- Periodic Dissection
- Periodic X-ray Analysis

Table 1. Voltage Ratings and Characteristics

Description	kV
Standard Voltage Class	35
Maximum Rating Phase-to-Ground	21.1
AC 60 Hz 1 Minute Withstand	
150 kV BIL Class BOL-T	50
200 kV BIL Class BOL-T	70
DC 15 Minute Withstand	103
BIL and Full Wave Crest	150/200
Minimum Partial Discharge Extinction Voltage	26

Voltage ratings and characteristics meet or exceed IEEE Std 386™-2016 standard.

Table 2. Current Ratings and Characteristics

Description	Amperes
Continuous	600 A rms (Aluminum) 900 A rms (Copper or Shear Bolt)
4 Hour Overload	900 A rms (Aluminum) 1,200 A rms (Copper or Shear Bolt)
Short Time	25,000 A rms symmetrical for 0.20 s
	10,000 A rms symmetrical for 4.0 s

Current ratings and characteristics meet or exceed IEEE Std 386™-2016 standard.

Optional features

Coppertop compression connectors

Coppertop compression connectors (aluminum sleeve welded to a copper spade) provide a high conductivity material in a bolted connection and are compatible with aluminum or copper conductors.

Shear bolt connectors

Bolted cable lug is fitted with stepless bolts, which shear off when optimum contact force has been reached. Provides electrical continuity for copper and aluminum conductors while eliminating need for dies and compression tools.

Current path

Full copper current carrying path can be obtained by specifying a coppertop compression connector, copper stud and copper insulating plug.

Ordering information

Each BOL-T Connector kit contains:

- Molded Rubber T-Body
- Insulating Plug
- Cap
- Compression or Shear Bolt Connector
- Cable Adapter
- Silicone Lubricant
- Installation Instruction Sheet

To order a 35 kV Class BOL-T Connector kit, see Steps 1-5 to build the catalog number.

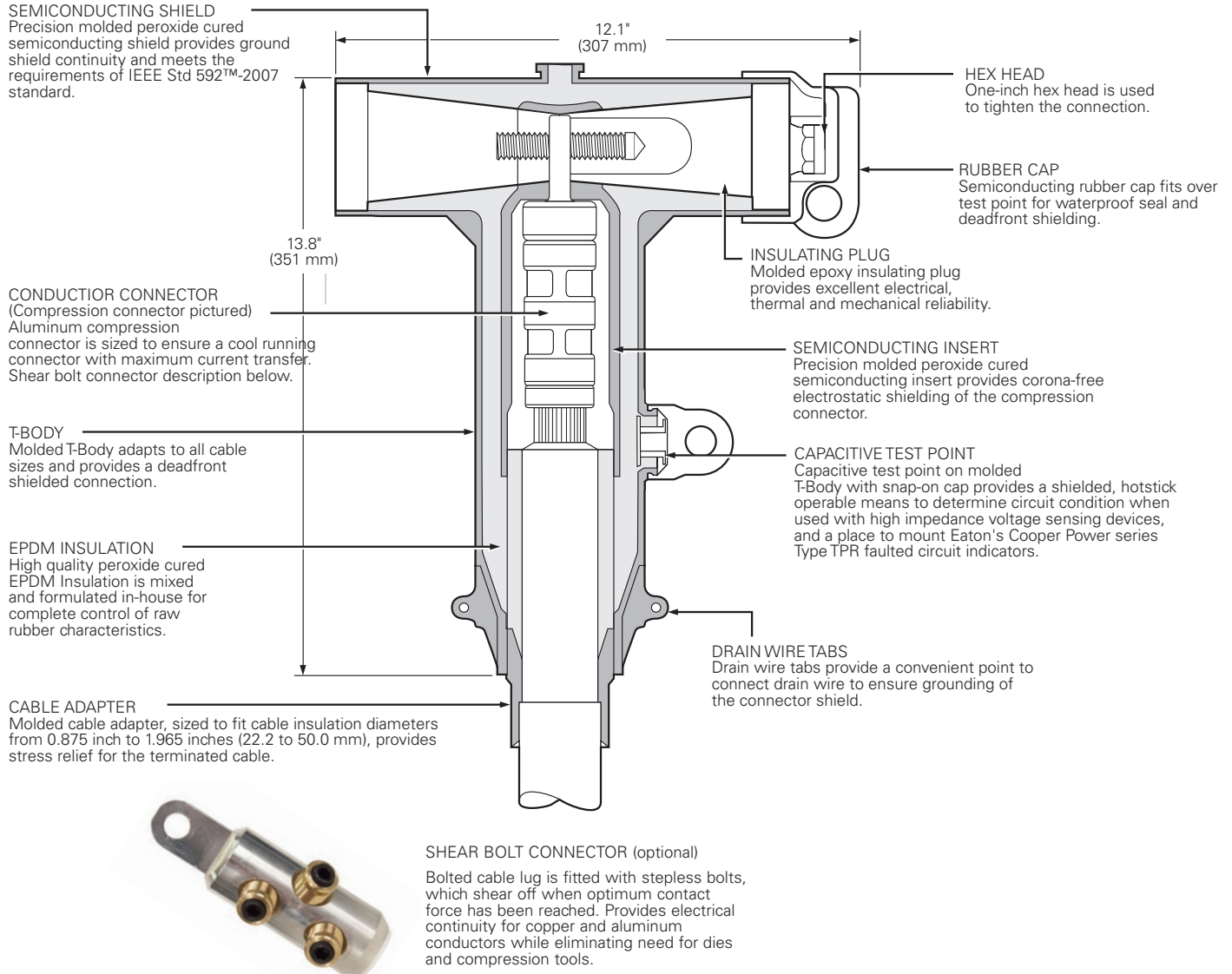

Figure 1. BOL-T cutaway illustrates design features.

Note: Dimensions given are for reference only.

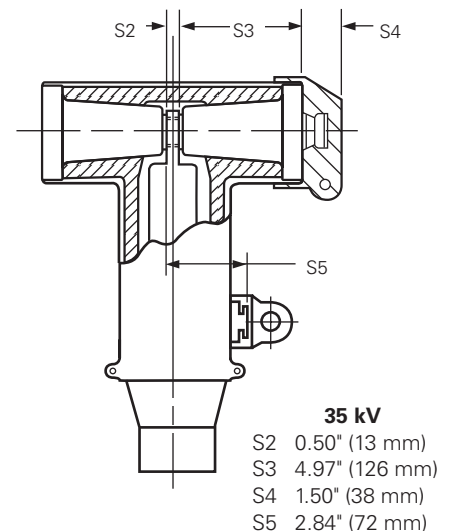

Figure 2. BOL-T Stacking Dimensions.

BOL-T Connector Kit – Catalog Numbering System

Build the 11 digit catalog number for a BOL-T kit by following the steps given below. The first 3 digits are "BT6"; so only digits 4 through 11 need to be selected.

1	2	3	4	5	6	7	8	9	10	11
B	T	6								

Catalog Number Digits:

- 1 & 2 = "BT," BOL-T Connector System
- 3 = "6," 600 A System

Step 1 – Select BIL Rating Requirement

- 4 & 5 = "35," 35 kV Class Bushing Interface, 150 kV BIL
- "38", 35 kV Class Bushing Interface, 200 kV BIL

Step 2 – Select Digit 6 Cable Adapter Range Code

Determine the cable's diameter over the electrical insulation as shown in Figure 3 (including tolerances).

Then identify a cable range from Table 3 that covers the minimum and maximum insulation diameters.

Select the correct CABLE RANGE CODE from Table 3.

Step 3 – Select Digits 7 and 8 Conductor Code

Identify the conductor size and type in Table 4 and select the CONDUCTOR CODE from the appropriate (compression or shear bolt) column.

Step 4 – Select Digit 9

Determine whether Aluminum or Copper is required for the compression connector, stud, and deadbreak insulating plug. .

- "A" = Aluminum (compression or shear bolt)
- "C" = Copper mating components (shear bolt or coppertop for the connector) Required to achieve 900 A rating.

Step 5 – Select Digit 10

Determine if a stud should be included in the kit. The stud will be fixed inside the deadbreak insulating plug.

- "1" = Stud Included
- "2" = Stud Not Included

Step 6 – Select Digit 11

Determine if the T-Body should have a test point.

- "T" = Test Point on T-Body

If no test point is required, do not include an 11th digit.

Table 3. Cable Diameter Range

Inches	mm	Cable Range Code	Inches	mm	Cable Range Code
0.875-0.985	22.2-25.0	D	1.355-1.520	34.4-38.6	M
0.930-1.040	23.6-26.4	E	1.485-1.595	37.7-40.5	N
0.980-1.115	24.9-28.3	F	1.530-1.640	38.9-41.7	P
1.040-1.175	26.4-29.8	G	1.575-1.685	40.0-42.8	Q
1.095-1.240	27.8-31.5	H	1.665-1.785	42.3-45.3	R
1.160-1.305	29.5-33.1	J	1.755-1.875	44.6-47.9	S
1.220-1.375	31.0-34.9	K	1.845-1.965	46.9-50.0	T
1.285-1.395	32.5-35.4	L	1.960-2.210	49.8-56.1	U

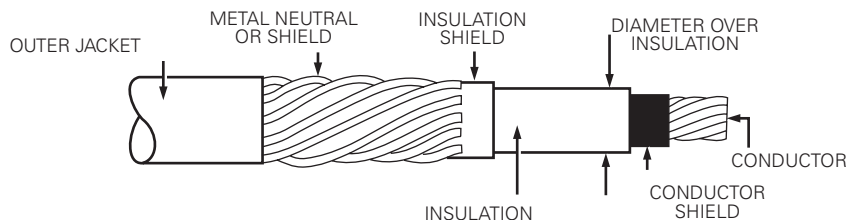

Figure 3. Illustration showing typical construction of medium voltage underground cable.

Table 4. Conductor Size and Type

Compression Connector					Shear Bolt Connector					
Concentric or Compressed		Compact or Solid		Compression Conductor Code	Cable Conductor Size				Shear Bolt Connector	
AWG or kcmil	mm²	AWG or kcmil	mm²		AWG or kcmil			mm² Standard Sized	Conductor Code	Catalog Number
					Compact	Compressed	Concentric			
No Connector				0	1/0	1/0	1/0	50		
#2	35	1	-	11	2/0	2/0	2/0	70		
#1	-	1/0	50	12	3/0	3/0	3/0	-	S1	CDT630SB150
1/0	50	2/0	70	13	4/0	4/0	4/0	95		
2/0	70	3/0	-	14	250	250	250	120		
3/0	-	4/0	95	15	350	-	-	150		
4/0	95	250	120	16	-	350	350	185		
250	120	300	-	17	500	500	500	240	S3	CDT630SB300
300	-	350	-	18	600	600	600	300		
350	-	400	185	19	700	-	-	-		
400	185	450	-	20	-	700	700	-		
450	-	500	240	21	750	750	750	-	S4	CDT630SB400
500	240	600	300	22	800	800	-	400		
600	300	700	-	23	900	-	-	-		
650	-	750	-	24	-	-	800	-		
750	-	900	-	25	-	900	900	-		
900	-	1000	500	26	1000	1000	1000	500	S6	CDT1250SB630
1000	500	-	-	27	-	1100	1100	-		
1250	630	-	-	28	-	1200	1200	-		
-	-	-	-	-	-	1250	1250	630		
-	-	-	-	-	-	1300	1300	-		
					-	1400	1400	-	S8	CDT1250SB800
					-	1500	1500	800		

Effective January 2020

EXAMPLE: Select a 200 kV BIL BOL-T kit for 250 kcmil compressed cable with a nominal insulation diameter of 1.16". The kit should have aluminum current-carrying parts and should have a stud included. The T-Body should have a test point.

Step 1 – Select Digits 4 and 5

This kit requires a 200 kV BIL interface.

Select "38" for digits 4 and 5.

Step 2 – Select Digit 6

Nominal diameter over insulation is $1.16" \pm .030"$.

Minimum diameter = $1.16" - .030" = 1.13"$.

Maximum diameter = $1.16" + .030" = 1.19"$.

From Table 3, identify the cable range that covers 1.13" - 1.19" and select the "H" cable range code.

Step 3 – Select Digits 7 and 8

The conductor size is 250 kcmil compressed. From Table 4, under the column "Concentric or Compressed," identify 250 kcmil and select the "17" conductor code.

Step 4 – Select Digit 9

This kit requires aluminum current-carrying parts. Select an "A" for digit 9.

Step 5 – Select Digit 10

This kit requires a stud, so select "1" for digit 10.

Step 6 – Select Digit 11

A test point is needed, so use a "T" for digit 11.

The complete catalog number is:

BT638H17A1T

Accessories

Cable adapters, compression connectors, and other accessories that can be used with BOL-T Connectors are described in Catalog Section CA650006EN, "Deadbreak Accessories, Tools, and Replacement Parts."

Table 5. Replacement Parts

Description	Catalog Number	
	150 kV BIL	200 kV BIL
T-Body without Test Point	DT635	DT638
T-Body with Test Point	DT635T	DT638T
Cap for Insulating Plug	DIPCAP	DIPCAP
Aluminum Insulating Plug with Cap (No Stud)	DIP635A	DIP638A
Aluminum Insulating Plug with Cap and Aluminum Stud*	DIP635AS	DIP638AS
Copper Insulating Plug with Cap (No Stud)	DIP635C	DIP638C
Copper Insulating Plug with Cap and Copper Stud*	DIP635CS	DIP638CS
5/8" – 11 UNC 2A Aluminum Threaded Stud	STUD635-A	STUD635-A
5/8" – 11 UNC 2A Copper Threaded Stud	STUD635-C	STUD635-C

* STUD comes loose in kit, add "P" to part number for factory installation.

This page is intentionally left blank.

Eaton
1000 Eaton Boulevard
Cleveland, OH 44122
United States
Eaton.com

Eaton's Power Systems Division
2300 Badger Drive
Waukesha, WI 53188
United States
Eaton.com/cooperpowerseries

© 2020 Eaton
All Rights Reserved
Printed in USA
Publication No.CA650008EN

Eaton is a registered trademark.
All other trademarks are property
of their respective owners.

For Eaton's Cooper Power series BOL-T
connector product information call
1-877-277-4636 or visit:
www.eaton.com/cooperpowerseries.