

600 A 15 kV class T-OP™ II deadbreak connector



General

Eaton terminates high-voltage underground cable to transformers, switches, switchgear and other apparatus with its Cooper Power™ series 600 A, 15 kV Class T-OP™ II deadbreak connector. It is fully shielded, submersible and meets the requirements of IEEE Std 386™-2006 standard – “Separable Insulated Connector Systems”.

The 200 A three-phase rated loadbreak interface provides a means for obtaining a live test, visible ground and visible break using a hotstick. It also provides a convenient location for Eaton's Cooper Power series M.O.V.E. arrester or grounding elbow.

Eaton offers an optional capacitive test point similar to test points on its Cooper Power series 200 A elbow connectors. This allows use of Eaton's Cooper Power series STLO, STHI, and STVT faulted circuit indicators.

T-OP II connectors are designed for use on solid dielectric cable (XLPE or EPR) with extruded semi-conducting shields and concentric neutral, with or without a jacket. Installation on jacketed concentric neutral cable may require additional sealing material. Adapters are available for terminating tape shield and drain wire jacketed cable.

900 AMP Rating

The T-OP II connector is rated for 900 A continuous when used with a copper bushing or junction.

Interchangeability

All Eaton's Cooper Power series 600 A deadbreak connectors conform to the electrical, mechanical and dimensional requirements of IEEE Std 386™-2006 standard. The connectors can be used on any comparably rated bushing interface that also meets the requirements of this standard. In addition, all T-bodies, cable adapters, insulating plugs and compression connectors are designed to be interchangeable with those currently available from other major manufacturers that also certify their components to IEEE Std 386™-2006 standard.

EAT•N

Powering Business Worldwide

Installation

The T-body is assembled onto prepared cable with a threaded coppertop compression connector using the alignment segment and a T-Wrench. The short end of a special copper alloy stud, provided with the kit, is torqued onto a de-energized 600 A bushing. The assembled housing is then connected to the apparatus bushing using an O & T tool (with cap) and an installation torque tool.

The T-OP II connector's unique back-off feature is accomplished by a captured rotating nut, which provides ease of removal of the T-OP II connector system from the apparatus bushing. (See Table 5 for information on tools.) Refer to Installation Instruction Sheet S600-12-3 for details.

Production tests

Tests are conducted in accordance with IEEE Std 386™-2006 standard.

- ac 60 Hz 1 Minute Withstand
 - 34 kV
- Minimum Partial Discharge Extinction Voltage
 - 11 kV

Tests are conducted in accordance with Eaton requirements.

- Physical Inspection
- Periodic Dissection
- Periodic Fluoroscopic Analysis

Table 1. Voltage Ratings and Characteristics

Description	kV
Standard Voltage Class	15
Maximum Rating Phase-to-Phase (loadbreak reducing tap plug only)	14.4
Maximum Rating Phase-to-Ground	8.3
AC 60 Hz 1 Minute Withstand	34
DC 15 Minute Withstand	53
BIL and Full Wave Crest	95
Minimum Partial Discharge Extinction Voltage	11

Voltage ratings and characteristics are in accordance with IEEE Std 386™-2006 standard.

Table 2. Current Ratings and Characteristics

Description	Amperes
600 A Interface	
Continuous	600 A rms (Aluminum) 900 A rms (Copper)
4 Hour Overload	900 A rms (Aluminum) 1,200 A rms (Copper)
Short Time	25,000 A rms symmetrical for 0.20 s 10,000 A rms symmetrical for 4.0 s
200 A Interface*	
Continuous	200 A rms
Switching	10 operations at 200 rms at 14.4 kV phase-to-phase
Fault Closure	10,000 A rms symmetrical at 14.4 kV phase-to-phase after 10 switching operations for 0.17 s
Short Time	10,000 A rms symmetrical for 0.17 s 3,500 A rms symmetrical for 3.0 s

Current ratings and characteristics are in accordance with IEEE Std 386™-2006 standard.

***NOTE:** System design and protection must recognize the ratings of 200 A interface.

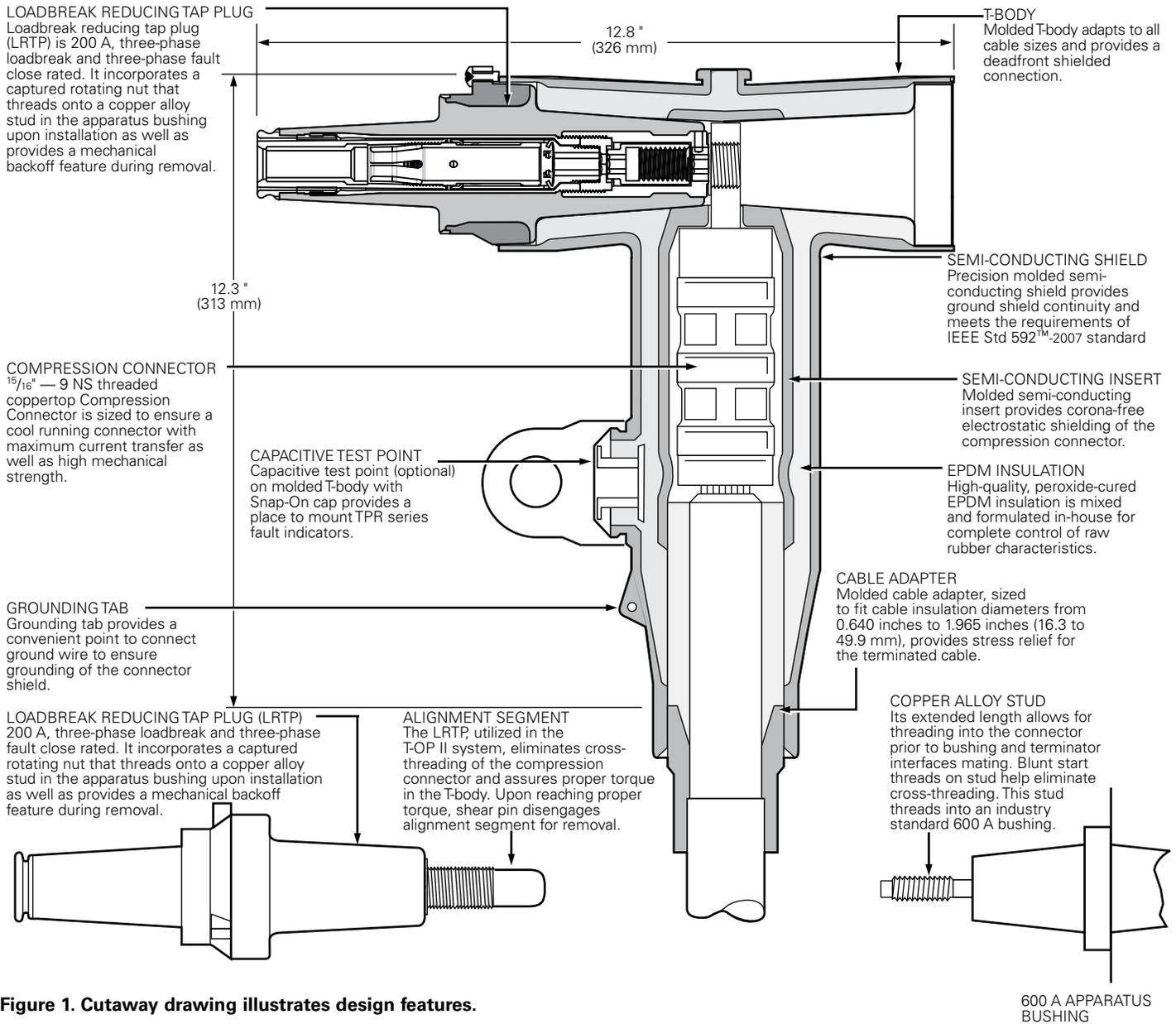

Figure 1. Cutaway drawing illustrates design features.

Note: Dimensions given are for reference only.

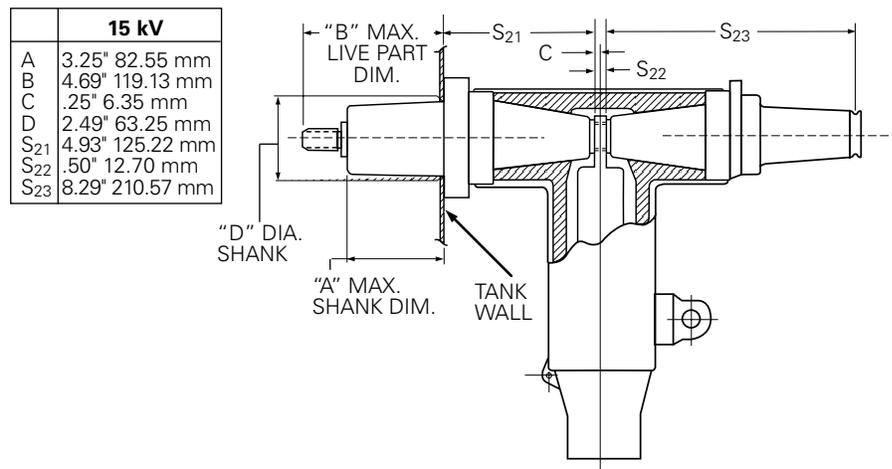

Figure 2. T-OP II profile and stacking dimension from Figure 11A of IEEE Std 386™-2006 standard.

Table 3. Cable Diameter Range

Cable Diameter Range		
Inches	mm	Code
0.610-0.970	15.5-24.6	AB
0.750-1.080	19.1-27.4	CC
0.970-1.310	24.6-33.3	DD
1.090-1.470	27.7-37.3	EE
1.260-1.640	32.0-41.7	FF
1.360-1.710	34.5-43.4	GG
1.500-1.850	38.4-47.0	HH
1.700-1.970	43.2-50.0	JJ

Table 4. Conductor Size and Type

Concentric or Compressed		Compact or Solid		CONDUCTOR CODE
AWG or kcmil	mm ²	AWG or kcmil	mm ²	
No Connector				00
3	–	2	–	10
2	–	1	–	11
1	–	1/0	–	12
1/0	50	2/0	70	13
2/0	70	3/0	–	14
3/0	–	4/0	95	15
4/0	95	250	120	16
250	120	300	–	17
300	–	350	–	18
350	–	400	185	19
400	185	450	–	20
450	–	500 ^a	240	21
500	240	600	300	22
600	300	700	–	23
650 ^b	–	750 ^c	–	24
750 ^d	–	900	–	25
900	–	1000	500	26
1000	500	–	–	27

a. Also accepts 550 kcmil compact conductor.
 b. Also accepts 700 kcmil compressed conductor.
 c. Also accepts 800 kcmil compact conductor.
 d. Also accepts 700 kcmil concentric conductor.

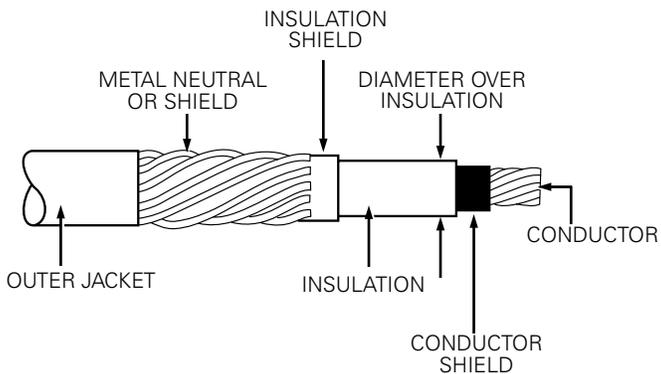

Figure 3. Illustration showing typical construction of medium voltage underground cable.

Ordering information

Each T-OP II connector kit contains:

- Molded Rubber T-body
- Loadbreak Reducing Tap Plug
- Cable Adapter
- Coppertop Compression Connector
- Copper Alloy Stud
- Silicone Lubricant
- Installation Instruction Sheet

Catalog number selection

Use the following procedure to develop the correct part number for the desired T-OP II connector kit, based on cable size, conductor size and desired options.

Step 1 – Determine the cable’s diameter over the electrical insulation as shown in Figure 3 (including tolerances). Then identify a cable range from Table 3 that brackets the minimum and maximum insulation diameters. Select the correct CABLE RANGE CODE.

Step 2 – Identify the conductor size and type in Table 4 and select the CONDUCTOR CODE from the far right column.

Step 3 – For a T-OP II connector kit with a capacitive test point and protective cap, order:



For a T-OP II kit without a capacitive test point or protective cap, order:



EXAMPLE: Select a T-OP II kit without a capacitive test point, with a protective cap for a 4/0 compressed cable with a nominal insulation diameter of 0.920".

Step 1 – Nominal diameter over the insulation is 0.920" ± .030"

minimum diameter = .920 - .030 = .890"

maximum diameter = .920 + .030 = .950"

From Table 3, identify the cable range .890" - .950" and select the "CC" Cable Range Code.

Step 2 – The conductor size is a 4/0 compressed. From Table 4, under the column "Concentric or Compressed," identify 4/0 and select the "16" conductor code.

Step 3 – Order catalog number:

TP615CC16C

To order replacement parts and tools, refer to Table 5.

To order replacement compression connectors and cable adapters for a T-OP II connector system, see *Catalog CA650007EN 600 A 15 and 25 kV Deadbreak Accessories, Tools and Replacement Parts.*

Optional features

Protective cap

200 A insulated protective cap fits over loadbreak reducing tap plug for deadfront shielding.

Capacitive test point

Capacitive Test Point on molded T-body, with snap-on cap, provides a place to mount STLO, STHI, and STVT faulted circuit indicators.

Table 5. Replacement Parts and Tools

Description	Catalog Number
T-body without Test Point	DT625
T-body with Test Point	DT625T
Loadbreak Reducing Tap Plug (LRTP)	L RTP615
Installation Torque Tool	TQHD625
Operating and Test Tool	OT625
Combination Operating and Test/Torque Tool	OTTQ615
5/16" T-Wrench	TWRENCH
Copper Alloy Stud	STUD-T
15 kV, 200 A Insulated Protective Cap	LPC215
5/16" Hex Shaft with 3/8" Socket Drive Tool	HD625

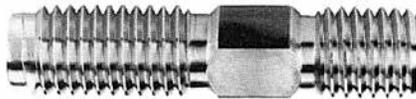

Figure 4. Catalog Number STUD-T.

The Copper Alloy Stud with its extended length allows for threading into the connector prior to mating the bushing and terminator interfaces. Blunt start threads on the stud help eliminate cross-threading. Stud threads into an industry standard 600 A bushing.



Figure 5. Catalog Number TWRENCH.

The T-Wrench is used to install the Loadbreak Reducing Tap Plug into the compression connector and T-body.



Figure 6. Catalog Number TQHD625.

The Torque Tool is required to check the torque of a 15 kV Class T-OP II deadbreak connector or bushing adapter when it is installed on a 600 A bushing interface. It is precision calibrated and hotstick operable.



Figure 7. Catalog Number OTTQ615.

The combination Operating and Test/Torque Tool is used with a hotstick to test for circuit de-energization and to install and remove a 15 kV Class LRTP equipped connector from an apparatus tap. The standard tool is equipped with a molded EPDM rubber cap and torque limiter to allow proper tool seating and gripping of the T-OP II connector. It also ensures that the connector has been properly torqued into the mating bushing.



Figure 8. Catalog Number HD625.

5/16" Hex Shaft with 3/8" socket drive tool.

Eaton
1000 Eaton Boulevard
Cleveland, OH 44122
United States
Eaton.com

Eaton's Cooper Power Systems Division
2300 Badger Drive
Waukesha, WI 53188
United States
Eaton.com/cooperpowerseries

© 2015 Eaton
All Rights Reserved
Printed in USA
Publication No. CA650017EN

Eaton, Cooper Power, and T-OP are valuable trademarks of Eaton in the U.S. and other countries. You are not permitted to use these trademarks without the prior written consent of Eaton.
IEEE Std 386™-2006 and IEEE Std 592™-2007 standards are trademarks of the Institute of Electrical and Electronics Engineers, Inc., (IEEE). This publication/product is not endorsed or approved by the IEEE.

For Eaton's Cooper Power series deadbreak connector product information call 1-877-277-4636 or visit: www.eaton.com/cooperpowerseries.