

600 A 15 kV class PUSH-OP™ deadbreak connector

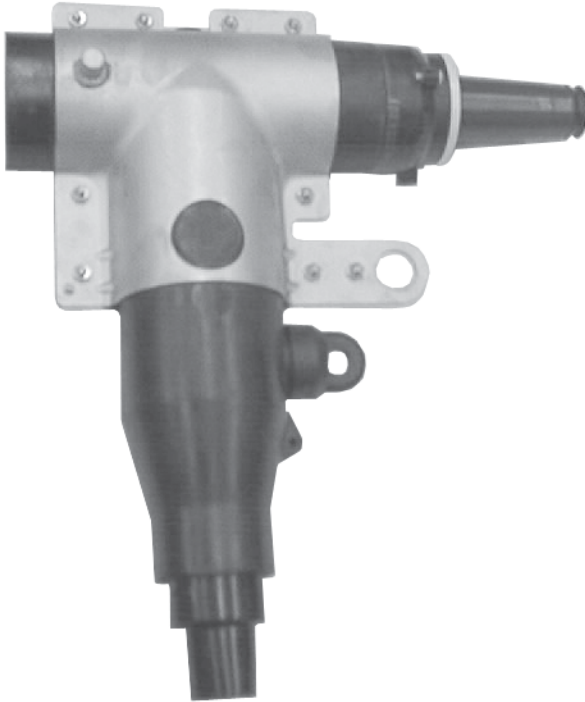

General

Eaton offers a complete threadless deadbreak, hotstick operable connection system for terminating underground cables to transformers, switches, switchgear, and other apparatus with its Cooper Power™ series 600 A, 15 kV Class PUSH-OP™ deadbreak connector. It is fully shielded, submersible, and meets the requirements of IEEE Std 386™ standard – Separable Insulated Connector Systems.

The design employs a unique, 600 A rated, plated copper probe and mating PUSH-OP bushing utilizing a plated copper finger contact system. The PUSH-OP connector's stainless steel latching, linkage mechanism provides leverage for easy disconnection of the terminator and easy handling of heavy cable. The result is a one-man, hotstick operable connection system that is unequalled in ease of operation and time required to perform sectionalizing operations.

A coppertop compression connector is provided for terminating the conductor.

The 200 A three-phase rated loadbreak interface provides a means for obtaining a live test, visible ground and visible break using a hotstick. It also provides a convenient location for an Eaton's Cooper Power series M.O.V.E. arrester or grounding elbow. The grounding elbow may be continuously connected to the PUSH-OP connector while moving it to and from an apparatus bushing.

Eaton offers an optional capacitive test point similar to test points on its Cooper Power series 200 A elbow connectors. This allows use of Eaton's Cooper Power series STLO, STHI, and STVT faulted circuit indicators.

The PUSH-OP connector also has a non-bolted connection that eliminates threading and its associated problems.

PUSH-OP connectors are designed for use on solid dielectric cable (XLPE or EPR) with extruded semi-conducting shields and concentric neutral, with or without jacket. Installation on jacketed concentric neutral cable may require additional sealing material. Cold shrinkable adapters are available for tape shield, linear corrugated and drain wire cable adaption for use with deadbreak connectors.

EATON

Powering Business Worldwide

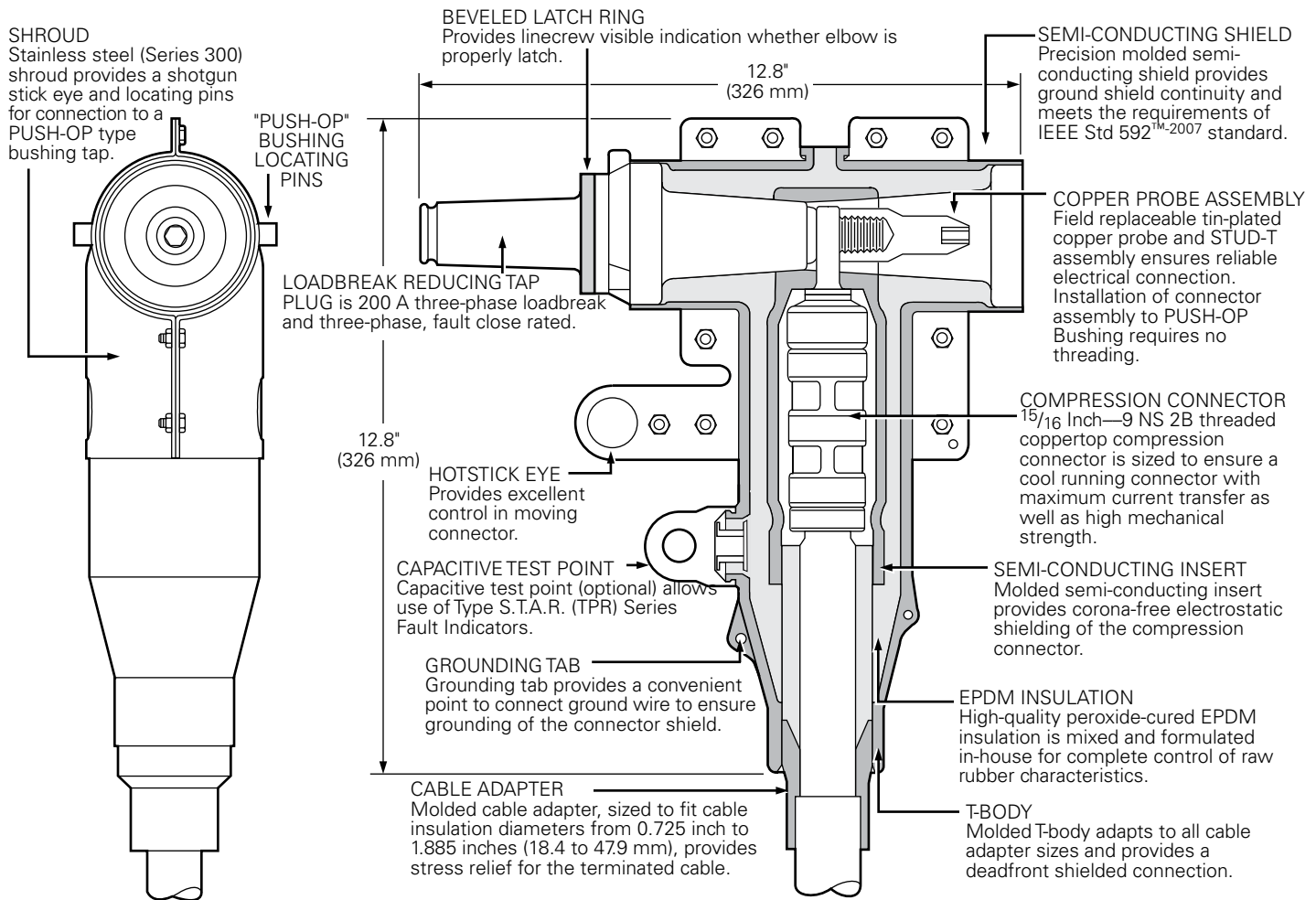

Figure 1. PUSH-OP cutaway illustrates design integrity.

Note: Dimensions given are for reference only.

Installation

The T-body housing with stainless steel shroud is assembled onto prepared cable with a coppertop threaded spade lug compression connector. The loadbreak reducing tap plug is threaded into the connector and onto a probe using an alignment tool, installation torque tool and T-wrench. The assembled housing is then connected to a de-energized 600 A PUSH-OP type bushing interface and bracket using hotline equipment without any threading operation. (See Table 5 for information on tools.) Refer to Installation Instruction Sheet S600-13-1 for details.

Production tests

Tests conducted in accordance with IEEE Std 386™-2006 standard:

- ac 60 Hz 1 Minute Withstand
 - 34 kV
- Minimum Partial Discharge Extinction Voltage
 - 11 kV

Tests conducted in accordance with Eaton requirements:

- Physical Inspection
- Periodic Dissection
- Periodic Fluoroscopic Analysis

Table 1. Voltage Ratings and Characteristics

Description	kV
Standard Voltage Class	15
Maximum Rating Phase-to-Phase (Loadbreak Reducing Tap Plug only)	14.4
Maximum Rating Phase-to-Ground	8.3
ac 60 Hz 1 Minute Withstand	34
dc 15 Minute Withstand	53
BIL and Full Wave Crest	95
Minimum Partial Discharge Extinction Voltage	11

Voltage ratings and characteristics are in accordance with IEEE Std 386™-2006 standard.

Table 2. Current Ratings and Characteristics

Description	Amperes
600 A Interface	
Continuous	600 A rms (Aluminum) 900 A rms (Copper)
24 Hour Overload	900 A rms (Aluminum) 1,200 A rms (Copper)
Short Time	25,000 A rms symmetrical for 0.20 s 10,000 A rms symmetrical for 4.0 s
200 A Interface*	
Continuous Switching	200 A rms 10 operations at 200 A rms at 14.4 kV phase-to-phase
Fault Closure	10,000 A rms symmetrical at 14.4 kV phase-to-phase for 0.17 s after 10 switching operations
Short Time	10,000 A rms symmetrical for 0.17 s 3,500 A rms symmetrical for 3.0 s

Current ratings and characteristics are in accordance with IEEE Std 386™-2006 standard.

* If available system fault current exceeds 10 kA, current limiting fusing must be used upstream. Otherwise fault close and short time ratings of the 200 A interface will be exceeded.

Optional features

Insulated Protective Cap

200 A insulated protective cap fits over loadbreak reducing tap plug for deadfront shielding.

Capacitive test point

Capacitive test point, on molded T-body, with snap-on cap, provides a place to mount Eaton's Cooper Power series STLO, STHI, and STVT faulted circuit indicators.

To order replacement compression connectors and cable adapters for a PUSH-OP connector, see *Catalog CA650006EN, 600 A 35 kV Deadbreak Accessories, Tools and Replacement Parts*.

Ordering information

Each PUSH-OP connector kit contains:

- Molded Rubber T-body with stainless steel shroud
- Loadbreak Reducing Tap Plug
- Cable Adapter
- Probe
- Compression Connector
- Alignment Tool
- Silicone Lubricant
- Installation Instruction Sheet
- Copper Alloy Stud

Catalog Number Selection

Use the following procedure to develop the correct part number for the desired PUSH-OP kit, based on cable size, conductor size and desired options.

Step 1 – Determine the cable's diameter over the electrical insulation as shown in Figure 2 (including tolerances). Then identify a cable range from Table 3 that brackets the minimum and maximum insulation diameters. Select the correct CABLE RANGE CODE.

Step 2 – Identify the conductor size and type in Table 4 and select the CONDUCTOR CODE from the far right column.

Step 3 – For a PUSH-OP kit with a capacitive test point and protective cap, order:

POP615 CABLE RANGE CODE CONDUCTOR CODE TC

For a PUSH-OP kit without a capacitive test point or protective cap, order:

POP615 CABLE RANGE CODE CONDUCTOR CODE

EXAMPLE: To select a PUSH-OP kit without a capacitive test point, with a protective cap for a 4/0 compressed cable with a nominal insulation diameter of 0.920".

Step 1 – Nominal diameter over the insulation is 0.920" ± .030"
 minimum diameter = .920 - .030 = .890"
 maximum diameter = .920 + .030 = .950"
 From Table 3 identify the cable range .890" - .950" and select the "CC" Cable Range Code.

Step 2 – The conductor size is a 4/0 compressed. From Table 4, under the column "Concentric or Compressed", identify 4/0 and select the "16" conductor code.

Step 3 – Order catalog number:

POP615CC16C

Table 3. Cable Diameter Range

Cable Diameter Range		
Inches	mm	Code
0.610-0.970	15.5-24.6	AB
0.750-1.080	19.1-27.4	CC
0.970-1.310	24.6-33.3	DD
1.090-1.470	27.7-37.3	EE
1.260-1.640	32.0-41.7	FF
1.360-1.710	34.5-43.4	GG
1.500-1.850	38.4-47.0	HH
1.700-1.970	43.2-50.0	JJ

Table 4. Conductor Size and Type

Concentric or Compressed		Compact or Solid		CONDUCTOR CODE
AWG or kcmil	mm ²	AWG or kcmil	mm ²	
No Connector				00
3	–	2	–	10
2	–	1	–	11
1	–	1/0	–	12
1/0	50	2/0	70	13
2/0	70	3/0	–	14
3/0	–	4/0	95	15
4/0	95	250	120	16
250	120	300	–	17
300	–	350	–	18
350	–	400	185	19
400	185	450	–	20
450	–	500 ^a	240	21
500	240	600	300	22
600	300	700	–	23
650 ^b	–	750 ^c	–	24
750 ^d	–	900	–	25
900	–	1000	500	26
1000	500	–	–	27

- a. Also accepts 550 kcmil compact conductor.
- b. Also accepts 700 kcmil compressed conductor.
- c. Also accepts 800 kcmil compact conductor.
- d. Also accepts 700 kcmil concentric conductor.

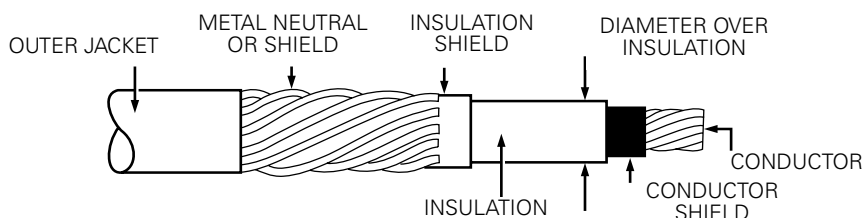

Figure 2. Illustration showing typical construction of medium voltage underground cable.

Table 5. Replacement Parts and Tools

Description	Catalog Number
T-body without Test Point with shroud	PDT625
T-body with Test Point with shroud	PDT625T
Loadbreak Reducing Tap Plug (includes STUD-T)	L RTP615
Probe and STUD-T Assembly	2638894B01B
200 A, 15 kV Class Insulated Protective Cap	LPC215
Installation Torque Wrench	TQHD625
5/16 inch T-Wrench	TWRENCH

See Catalog CA650006EN for replacement compression connectors, cable adapters and additional information on tools.



Figure 3. Catalog Number TWRENCH
The T-Wrench is used to install the loadbreak reducing tap plug into the compression connector and T-body.



Figure 4. Catalog Number TQHD625
The Torque Tool is required to assemble a 15/25 kV Class PUSH-OP Deadbreak Connector. It is precision calibrated and hotstick operable.

Eaton
1000 Eaton Boulevard
Cleveland, OH 44122
United States
Eaton.com

Eaton's Cooper Power Systems Division
2300 Badger Drive
Waukesha, WI 53188
United States
Eaton.com/cooperpowerseries

© 2015 Eaton
All Rights Reserved
Printed in USA
Publication No. CA650016EN

Eaton, Cooper Power, PUSH-OP, M.O.V.E., and S.T.A.R. are valuable trademarks of Eaton in the U.S. and other countries. You are not permitted to use these trademarks without the prior written consent of Eaton. IEEE Std 386™-2006 and IEEE Std 592™-2007 standards are trademarks of the Institute of Electrical and Electronics Engineers, Inc. This publication/product is not endorsed or approved by the IEEE.

For Eaton's Cooper Power series deadbreak connector product information call 1-877-277-4636 or visit: www.eaton.com/cooperpowerseries.