

600 A 15 kV and 25 kV class BT-TAP™ connector system installation instructions



DISCLAIMER OF WARRANTIES AND LIMITATION OF LIABILITY

The information, recommendations, descriptions and safety notations in this document are based on Eaton Corporation's ("Eaton") experience and judgment and may not cover all contingencies. If further information is required, an Eaton sales office should be consulted. Sale of the product shown in this literature is subject to the terms and conditions outlined in appropriate Eaton selling policies or other contractual agreement between Eaton and the purchaser.

THERE ARE NO UNDERSTANDINGS, AGREEMENTS, WARRANTIES, EXPRESSED OR IMPLIED, INCLUDING WARRANTIES OF FITNESS FOR A PARTICULAR PURPOSE OR MERCHANTABILITY, OTHER THAN THOSE SPECIFICALLY SET OUT IN ANY EXISTING CONTRACT BETWEEN THE PARTIES. ANY SUCH CONTRACT STATES THE ENTIRE OBLIGATION OF EATON. THE CONTENTS OF THIS DOCUMENT SHALL NOT BECOME PART OF OR MODIFY ANY CONTRACT BETWEEN THE PARTIES.

In no event will Eaton be responsible to the purchaser or user in contract, in tort (including negligence), strict liability or otherwise for any special, indirect, incidental or consequential damage or loss whatsoever, including but not limited to damage or loss of use of equipment, plant or power system, cost of capital, loss of power, additional expenses in the use of existing power facilities, or claims against the purchaser or user by its customers resulting from the use of the information, recommendations and descriptions contained herein. The information contained in this manual is subject to change without notice.

Contents

SAFETY INFORMATION

Safety Information	iv
--------------------------	----

PRODUCT INFORMATION

Introduction	1
Acceptance and Initial Inspection	1
Handling and Storage	1
Standards	1

EQUIPMENT REQUIRED

Equipment Required	2
--------------------------	---

TOOLS REQUIRED

Tools Required	2
----------------------	---

INSTALLATION OF CONNECTORS

Shear Bolt Installation Procedure	2
Compression Connector Procedure	7

COMPLETING T-BODY TERMINATION

Installation of BT-TAP Assembly Onto Apparatus Bushing	12
--	----



Safety for life



Eaton meets or exceeds all applicable industry standards relating to product safety with its Cooper Power™ series products. We actively promote safe practices in the use and maintenance of our products through our service literature, instructional training programs, and the continuous efforts of all Eaton employees involved in product design, manufacture, marketing, and service.

We strongly urge that you always follow all locally approved safety procedures and safety instructions when working around high voltage lines and equipment, and support our “Safety For Life” mission.

Safety information

The instructions in this manual are not intended as a substitute for proper training or adequate experience in the safe operation of the equipment described. Only competent technicians who are familiar with this equipment should install, operate, and service it.

A competent technician has these qualifications:

- Is thoroughly familiar with these instructions.
- Is trained in industry-accepted high and low-voltage safe operating practices and procedures.
- Is trained and authorized to energize, de-energize, clear, and ground power distribution equipment.
- Is trained in the care and use of protective equipment such as arc flash clothing, safety glasses, face shield, hard hat, rubber gloves, clampstick, hotstick, etc.

Following is important safety information. For safe installation and operation of this equipment, be sure to read and understand all cautions and warnings.

Hazard Statement Definitions

This manual may contain four types of hazard statements:

DANGER

Indicates an imminently hazardous situation which, if not avoided, will result in death or serious injury.

WARNING

Indicates a potentially hazardous situation which, if not avoided, could result in death or serious injury.

CAUTION

Indicates a potentially hazardous situation which, if not avoided, may result in minor or moderate injury.

CAUTION: Indicates a potentially hazardous situation which, if not avoided, may result in equipment damage only.

Safety instructions

Following are general caution and warning statements that apply to this equipment. Additional statements, related to specific tasks and procedures, are located throughout the manual.

DANGER

Hazardous voltage. Contact with hazardous voltage will cause death or severe personal injury. Follow all locally approved safety procedures when working around high- and low-voltage lines and equipment.

G103.3

WARNING

Before installing, operating, maintaining, or testing this equipment, carefully read and understand the contents of this manual. Improper operation, handling or maintenance can result in death, severe personal injury, and equipment damage.

G101.0

WARNING

This equipment is not intended to protect human life. Follow all locally approved procedures and safety practices when installing or operating this equipment. Failure to comply can result in death, severe personal injury and equipment damage.

G102.1

WARNING

Power distribution and transmission equipment must be properly selected for the intended application. It must be installed and serviced by competent personnel who have been trained and understand proper safety procedures. These instructions are written for such personnel and are not a substitute for adequate training and experience in safety procedures. Failure to properly select, install or maintain power distribution and transmission equipment can result in death, severe personal injury, and equipment damage.

G122.3

⚠ DANGER

All associated apparatus must be de-energized during any hands-on installation or maintenance.

⚠ WARNING

The 600 A BT-TAP Connector System is designed to be operated in accordance with normal safe operating procedures. These instructions are not intended to supersede or replace existing safety and operating procedures. The elbow connector should be installed and serviced only by personnel familiar with good safety practices and the handling of high-voltage electrical equipment.

⚠ WARNING

Optional Capacitive Test Point Operating Instructions: Use only voltage indicating instruments specifically designed for test points. Use of conventional voltage sensing devices may provide false “No Voltage” indications.

The test point must be dry and free of contaminant’s when checking for voltage. After indication is taken: clean, dry, and lubricate the test point cap with silicone grease and assemble to the test point.

The capacitive test point is not sufficiently accurate, nor is it intended for, actual voltage measurements or phasing operations.

A reading of no voltage from the test point should not be the only indication of a de-energized circuit obtained before touching the connector. Other procedures can include direct conductor voltage testing or grounding using a live-line tool.

Product information

Introduction

Eaton terminates high-voltage underground cable to deadfront apparatus such as transformers, switches, and switchgear with its Cooper Power™ series 600 A 15 kV and 25 kV Class BT-TAP™ deadbreak connectors. They are fully shielded, submersible, and meet the requirements of the IEEE Std 386™ standard— “Separable Insulated Connector Systems”. Eaton’s 600 A deadbreak connectors are fully interchangeable with all other manufacturers that also certify compliance with the IEEE Std 386™ standard. The BT-TAP connector is rated for 900 A when used with all copper current carrying components.

Read this manual first

Read and understand the contents of this manual and follow all locally approved procedures and safety practices before installing or operating this equipment

Additional information

These instructions cannot cover all details or variations in the equipment, procedures, or process described nor provide directions for meeting every possible contingency during installation, operation, or maintenance. When additional information is desired to satisfy a problem not covered sufficiently for the user’s purpose, please contact your Eaton representative.

Acceptance and initial inspection

Each deadbreak connector is completely inspected and tested at the factory. It is in good condition when accepted by the carrier for shipment. Upon receipt of a deadbreak connector, inspect it thoroughly for damage and loss of parts incurred during shipment. If damage or loss is discovered, file a claim with the carrier immediately.

Handling and storage

If the deadbreak connector is to be stored for an appreciable time before installation, provide a clean, dry storage area.

Quality standards

ISO 9001-Certified quality management system

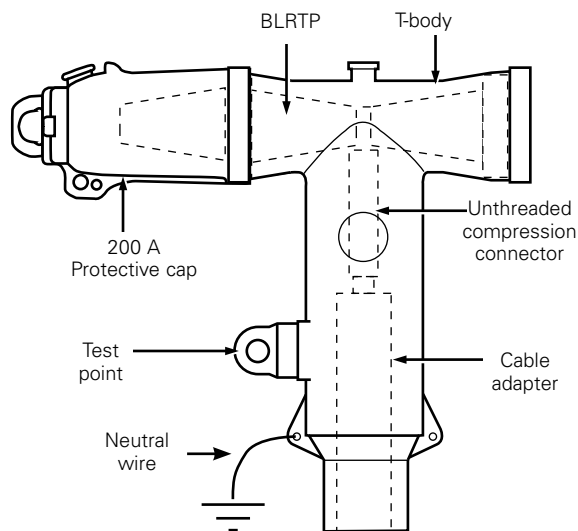

Figure 1. Line illustration of typical 15 kV BT-TAP Connector Assembly.

IMPORTANT

Installation Instructions to be used for 600 A, 15 and 25 kV Class BT-TAP connector with shear bolt connector. Please see page 7 for installation instructions using a compression connector.

Note: If concentric neutral cable is not being used, follow cable preparation directions in shield adapter kit.

Equipment provided

- BT-TAP Connector assembly kit includes:
 - Tbody
 - Cable adapter
 - BT-TAP Loadbreak reducing tap plug (BLRTP)
 - Threaded Stud
 - 200 A Loadbreak protective cap (when furnished)
 - Shear bolt connector
 - Silicone lubricant
 - Instruction sheet

Tools required

- Torque wrench
- 5/16" Hex wrench for splice application
- Cable stripping tools
- 5 mm or 8 mm Allen wrench

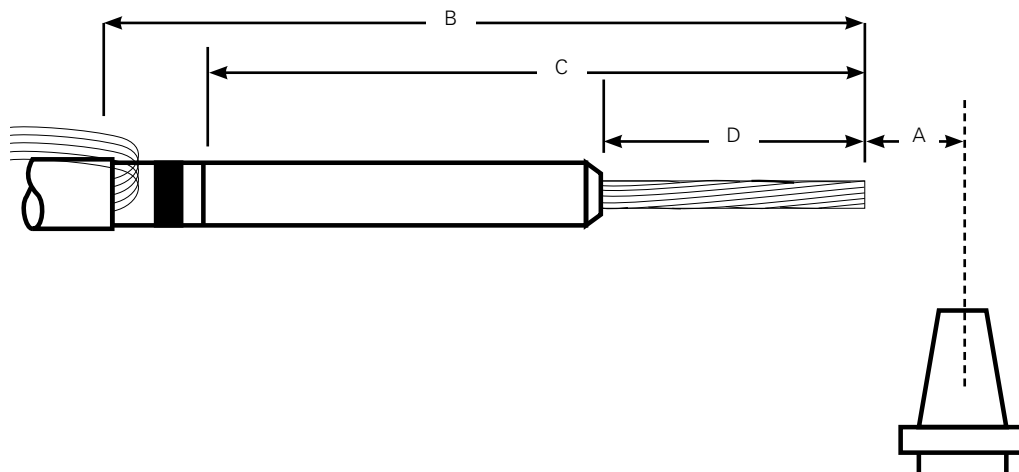

Figure 2. Strip back dimensions.

Installation of connectors

Shear bolt installation procedure

(For compression connector procedures, see page 7)

Prepare the cable

Step 1.

Train cable

- Position cable vertically so that it is centered between apparatus bushing and parking pocket, parallel to, and 6" (152 mm) from apparatus frontplate.
- Provide adequate cable slack for cable movement between standoff bushing and apparatus bushing.
- Support cable as needed to maintain position.
- Cut cable to length "A" from centerline of bushing. (Refer to Figure 3 and Table 2 for "A" length).

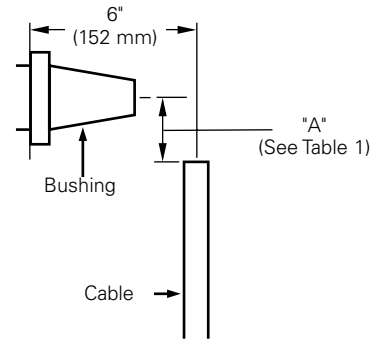

Figure 3. Line illustration for cable training.

Table 1. Shear bolt connector

Cable conductor size				Shear bolt connector		
AWG or kcmil			mm2 Standard sizes	Centering ring & color	Conductor code	Catalog number
Compact	Compressed	Concentric				
1/0	1/0	1/0	25	Grey	S1	CDT630SB150
2/0	2/0	2/0	-			
3/0	3/0	3/0	-			
4/0	4/0	4/0	95	Black		
250	250	250	120			
300	300	300	150	None		
350	350	350	185	Black		
500	500	500	240	None	S3	CDT630SB300
600	550	550	300			
700	600	600				
750	750	750	400	None	S4	CDT630SB400
800	800	800				

Table 2. Shear bolt stripback dimensions

Length variable	Measurement name	Tolerance in. (mm)	Connector code	S1	S3	S4
			Allen wrench (mm)	5	8	8
				Cutbacks	in (mm)	in (mm)
A	Bushing to cable	+/- ¼ (+/- 6.4)		2 (50.8)	2 (50.8)	2 (50.8)
B	Jacket	+/- ¼ (+/- 6.4)		13 (330.2)	13 (330.2)	13 (330.2)
C	Insulation shield	+/- 1/8 (+/- 3.2)		10½ (266.7)	10½ (266.7)	10½ (266.7)
D	Conductor	+/- 1/8 (+/- 3.2)		2¼ (57.2)	2¾ (69.9)	3¼ (82.6)
E	Cable adapter check	Maximum		7½ (190.5)	7½ (190.5)	7½ (190.5)

Step 2.

Remove concentric neutral wires or jacket

Note: Care should be taken to not cut or score the neutral conductors when cutting the cable jacket.

- Measure reference length "B" from end of cable. (Refer to Figure 4 and Table 2 to determine variable "B" length.
 - For jacketed neutral cable, remove jacket to "B" dimension.
 - For unjacketed neutral cable, bind neutral wires using three (3) wraps of tape at "B" dimension.
- Pull back concentric neutral wires. Allow enough extra concentric neutral wires to connect to ground after installation and allow movement to insulated standoff bushing.

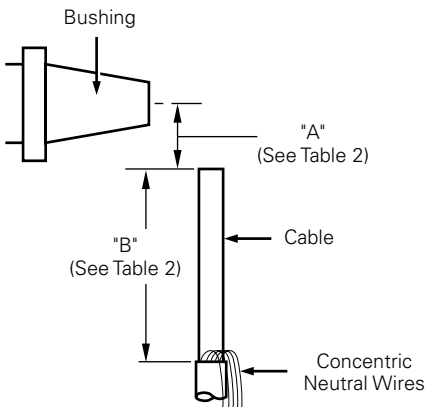

Figure 4. Line illustration of removing concentric neutral wires.

Step 3.

Remove insulation shield

- Remove insulation shield length "C" from end of cable. (Refer to Figure 5 and Table 2 to determine variable "C" length.)

Note: Do not cut or nick insulation.

Step 4.

Put tape marker in place

- Measure 1" (25 mm) from end of insulation shield. (Refer to Figure 5.)
- Wrap two turns of tape to serve as marker for cable adapter location.

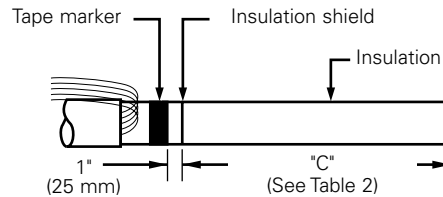

Figure 5. Line illustration of cable stripback.

Step 5.

Remove conductor insulation

Note: Do not pencil cable.

- Remove insulation exposing bare conductor to length of "D". (Refer to Figure 6 and Table 2 to determine variable "D" length.)

Note: Do not unwind conductor strands.

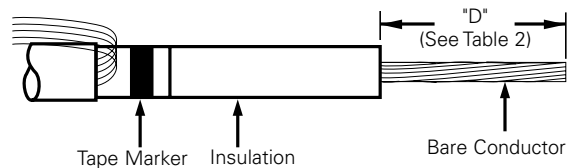

Figure 6. Line illustration of bare conductor length.

Step 6.

Bevel insulation

- Remove sharp edge of insulation by beveling at a 45° angle for approximately 1/4" (6 mm). (Refer to Figure 7.)

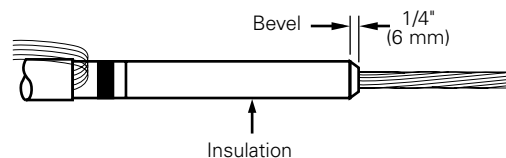

Figure 7. Line illustration of insulation bevel.

Step 7.

Clean insulation

Note: Do not apply solvent directly to cable.

- Clean insulation thoroughly with solvent dampened rag, wiping from conductor end toward insulation shield. (Refer to Figure 8.)
- Ensure that all traces of conductive residue are removed.

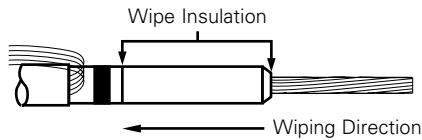

Figure 8. Line illustration of insulation cleaning.

Step 8.

Lubricate and install cable adapter

- Lubricate exposed cable insulation.
- Lubricate inside of cable adapter.
- Slide small end of cable adapter over cable using twisting motion until small end is flush with tape marker. (Refer to Figure 9.)
- After sliding the cable adapter into position make sure that no bulge is present (see Figure 10).

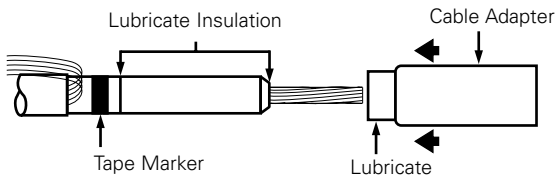

Figure 9. Line illustration of insulation cable adapter.

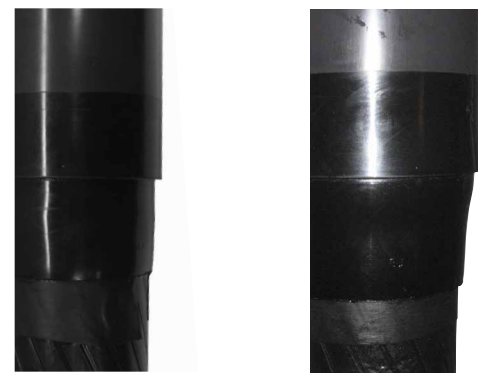
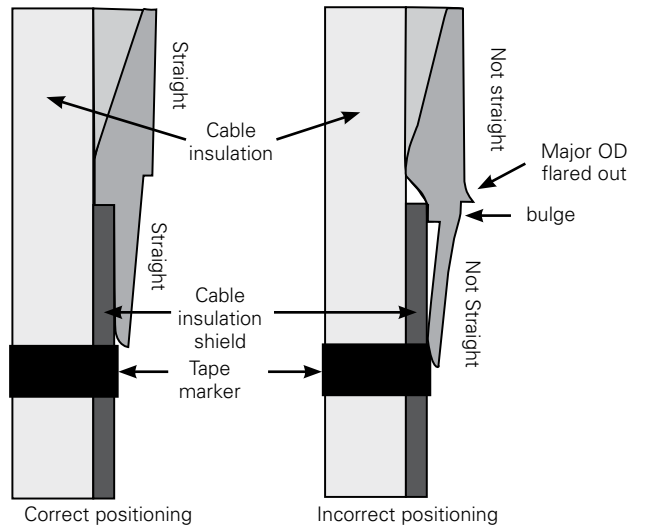

Figure 10. Cross sectional view of cable adapter positioning.

WARNING

Equipment Damage/Personal Injury. Improperly positioned cable adapter may result in equipment damage or personal injury.

Step 9.

Install shear bolt connector

Note: Refer to the separate installation instructions supplied with the shear bolt connector.

- Install centering ring.
 - Refer to Figure 11 and Table 1 to determine what size conductors require a centering ring and the correct color to use.
- Wire brush conductor (aluminum only).
- Immediately insert the conductor completely into the barrel of the lug and rotate connector to distribute inhibitor.
- Align flats of connector and apparatus bushing for minimum conductor strain.

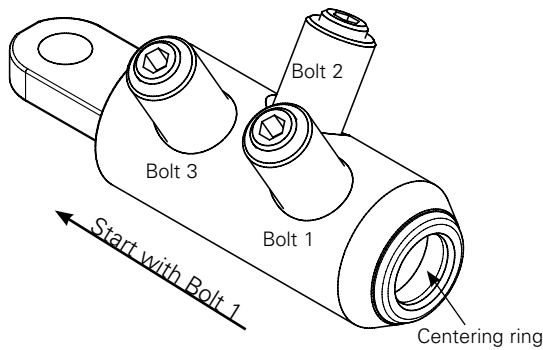

Figure 11. Mechanical lug tightening sequence.

Note: Connector must be fully seated on cable conductor.

- With an Allen hex key as specified in Table 2 screw in bolt No. 1 until it breaks off smoothly. Proceed with bolt No. 2 in a similar way. If the lug has more than two (2) bolts, continue with bolt No. 3 and bolt No. 4, (not shown in Figure 11). See Figure 11 for tightening sequences.
- Once all the bolts have broken off, smooth any rough edges with a file and install the covering caps. Carefully clean off any filings.
- Wipe excess inhibitor from connector and adapter surfaces.

Step 10.

Check dimensions

- Check length from end of compression connector to top of cable adapter.
- Length should be no longer than "E" dimension. (Refer to Figure 12 and Table 2.)

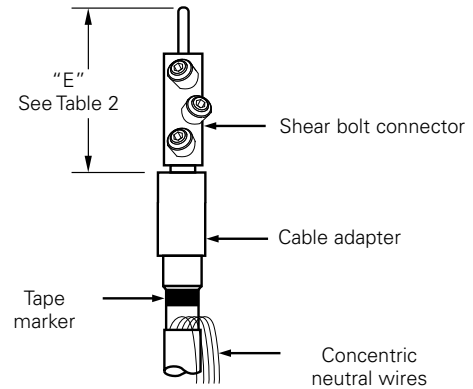

Figure 12. Line illustration for dimensional check.

Install BOL-T T-body with mating parts

Step 11.

Install DT625 T-body

- Clean and lubricate outside of cable adapter with lubricant supplied.
- Clean and lubricate inside of T-body with lubricant supplied.

Note: If test point T-body is used, insure test point is opposite front plate side of T-body.

- Without moving the cable adapter, slide T-body onto cable adapter until compression connector eye is centered in 600 A interfaces. (Refer to Figure 13.)

Note: The end of the cable adapter must line up with the top edge of the tape marker after T-body assembly. Refer to Figure 10.

- Remove tape marker from cable.

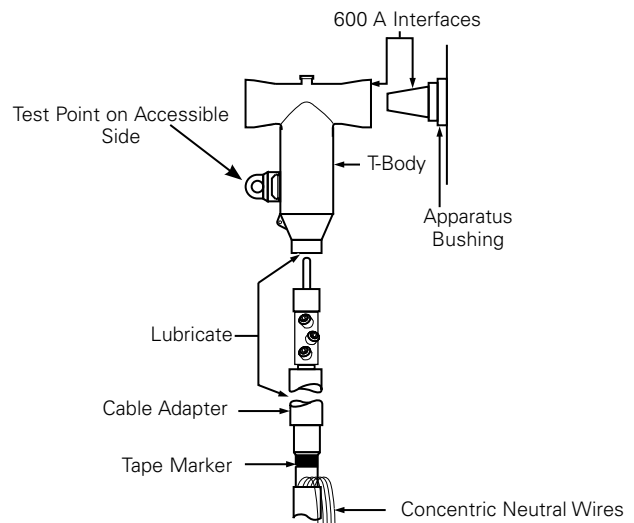

Figure 13. Line illustration of BOL-T T-body installation.

- Go to Step 12, page 12 to complete T-body termination.

Compression connector procedures

Equipment provided

- BT-TAP Connector Assembly Kit includes:
 - T-body
 - Cable Adapter
 - Compression Connector with 11/16" unthreaded spade
 - BT-TAP Loadbreak Reducing Tap Plug (BLRTP)
 - Threaded Stud
 - 200 A Loadbreak Protective Cap (when furnished)
 - Silicone Lubricant
 - Instruction Sheets

Tools required

- 5/16" Hex Shaft (Catalog Number HD625)
- Cable Stripping Tools
- Torque Wrench

Table 3. Conductor size and type

Compression connector				
Concentric or Compressed		Compact or Solid		Compression conductor code
AWG or kcmil	mm ²	AWG or kcmil	mm ²	
No connector				00
#2	35	1	-	11
#1	-	1/0	50	12
1/0	50	2/0	70	13
2/0	70	3/0	-	14
3/0	-	4/0	95	15
4/0	95	250	120	16
250	120	300	-	17
300	-	350	-	18
350	-	400	185	19
400	185	450	-	20
450	-	500	240	21

Prepare the cable

Note: If a non-Eaton's Cooper Power series 600 A T-body is being used, use the stripback lengths given in the T-body kit, then proceed to Step 7 of these instructions.

Step 1.

Train cable

- Position cable vertically so that it is centered between apparatus bushing and parking pocket, parallel to and 6" (152 mm) from apparatus frontplate.
- Provide adequate cable slack for cable movement between standoff bushing and apparatus bushing.
- Support cable as needed to maintain position.
- Cut cable 1 3/4" (44 mm) from centerline of bushing. Refer to Figure 14.

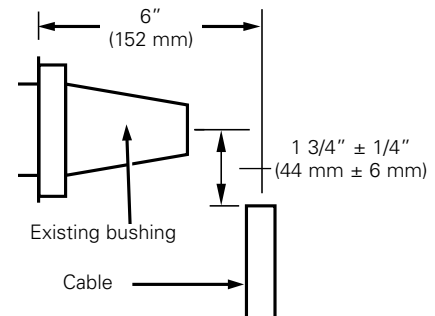

Figure 14. Line illustration for cable training.

Step 2.

Remove concentric neutral wires or jacket

Note: Care should be taken to not cut or score the neutral conductors when cutting the cable jacket.

- Measure 12 3/4" (324 mm) from end of cable. Refer to Figure 15.
- For jacketed neutral cable, remove jacket to 12 3/4" dimension.
 - For unjacketed neutral cable, bind neutral wires using three (3) wraps of tape at 12 3/4" dimension.
- Pull back concentric neutral wires. Allow enough extra concentric neutral wires to connect to ground after installation and allow movement to insulated standoff bushing.

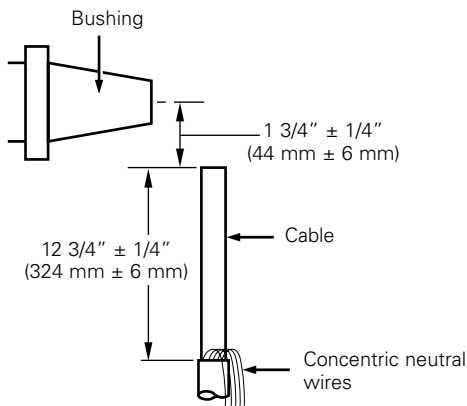

Figure 15. Line illustration of removing concentric neutral wires.

Step 3.

Remove insulation shield

- Remove insulation shield length 9 3/4" (248 mm) from end of cable. Refer to Figure 16.
- Do not cut or nick insulation.

Step 4.

Put tape marker in place

- Measure 1" (25 mm) from end of insulation shield. Refer to Figure 16.
- Wrap two turns of tape to serve as marker for cable adapter location.

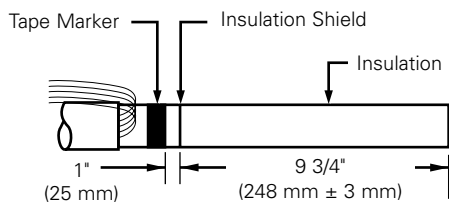

Figure 16. Line illustration of cable stripback.

Step 5.

Remove conductor insulation

Note: Do not pencil cable.

- Remove insulation exposing bare conductor to length of 4 3/8" (111 mm). Refer to Figure 17.

Note: Do not unwind conductor strands.

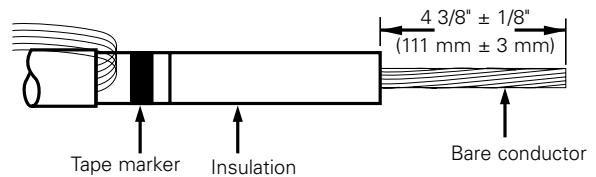

Figure 17. Line illustration of bare conductor length.

Step 6.

Bevel insulation

- Remove sharp edge of insulation by beveling at a 45° angle for approximately 1/4" (6 mm). Refer to Figure 18.

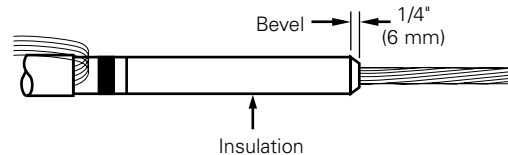

Figure 18. Line illustration of insulation bevel.

Step 7.

Clean insulation

Note: Do not apply solvent directly to cable.

- Clean insulation thoroughly with solvent dampened rag, wiping from conductor end toward insulation shield. (Refer to Figure 19.)
- Ensure that all traces of conductive residue are removed.

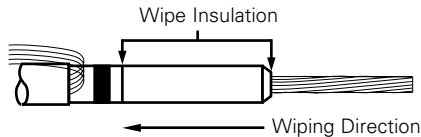

Figure 19. Line illustration of insulation cleaning.

Step 8.

Lubricate and install cable adapter

- Lubricate exposed cable insulation.
- Lubricate inside of cable adapter.
- Slide small end of cable adapter over cable using twisting motion until small end is flush with tape marker. Refer to Figure 20.
- After sliding the cable adapter into position make sure that no bulge is present. Refer to Figure 21.

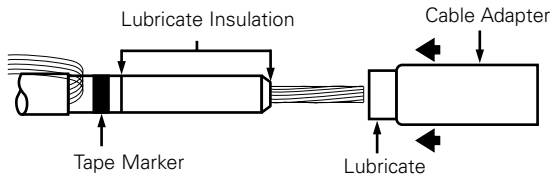

Figure 20. Line illustration of insulation cable adapter.

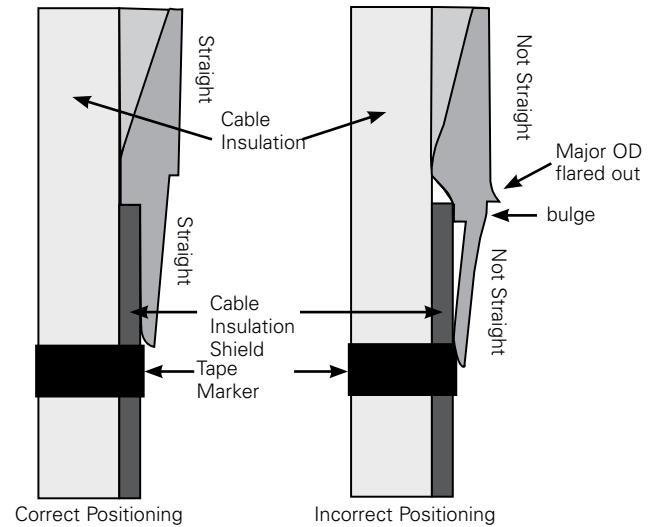

Figure 21. Cross sectional view of cable adapter positioning.

WARNING

Equipment Damage/Personal Injury. Improperly positioned cable adapter may result in equipment damage or personal injury.

Step 9.

Install compression connector

Note: Refer to the chart supplied with the crimp connector for tool and die to be used.

- Wire brush conductor (aluminum only).
- Remove protective cap from compression connector.
- Insert conductor completely into compression connector and rotate connector to distribute inhibitor.

Note: Connector must be fully seated on cable conductor.

- Align flats of connector and apparatus bushing for minimum conductor strain.
- Make first crimp 1/2" (13 mm) below shoulder of compression connector. (Refer to Figure 22).
- Rotate each successive crimp 90° on compression connector and allow 1/8" (3 mm) between crimps.
- Wipe excess inhibitor from connector and adapter surfaces.

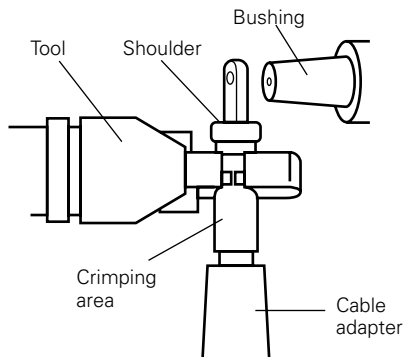

Figure 22. Line illustration of crimping area.

Step 10.

Check dimensions

- Check length from end of compression connector to top of cable adapter.
- Length should be between 6 1/2" - 7 1/4" (165 - 184 mm). (Refer to Figure 23.)

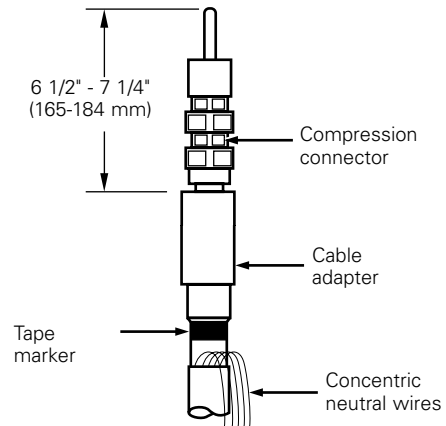

Figure 23. Line illustration for dimensional check.

Install BOL-T T-body with mating parts**Step 11.****Install DT625 T-body**

- Clean and lubricate outside of cable adapter with lubricant supplied.
- Clean and lubricate inside of T-body with lubricant supplied.

Note: If test point T-body is used, insure test point is opposite front plate side of T-body.

- Without moving the cable adapter, slide T-body onto cable adapter until compression connector eye is centered in 600 A interfaces. (Refer to Figure 24.)

Note: The end of the cable adapter must line up with the top edge of the tape marker after T-body assembly. Refer to Figure 21.

- Remove tape marker from cable.

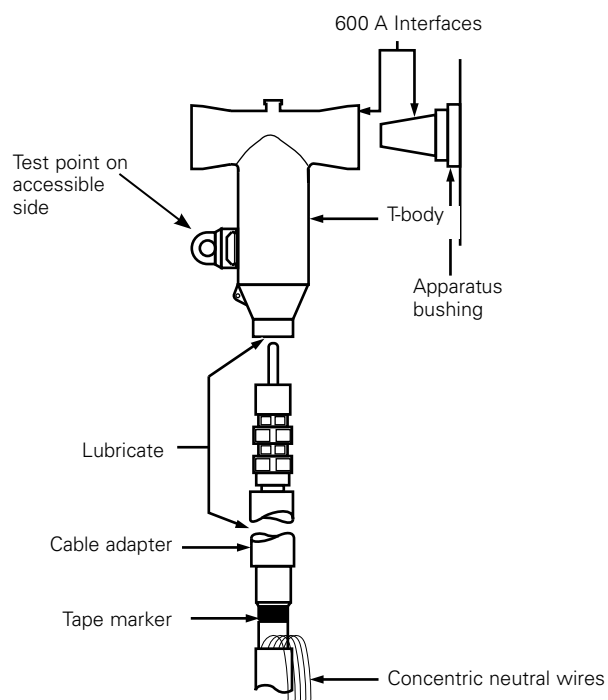

Figure 24. Line illustration of BOL-T T-body installation.

- Go to Step 12, page 12 to complete T-body termination.

Completing T-body termination

Step 12.

Install stud into apparatus bushing

- Ensure unit is de-energized.
- Thread the shorter threaded end of extended stud into the apparatus bushing until hand tight. Refer to Figure 25.
- Engage the flats on the stud with a 1/2" wrench and thread the stud into the bushing an additional 1/4 revolution past hand tight.
- Remove any shavings that may have been raised during the threading procedure.

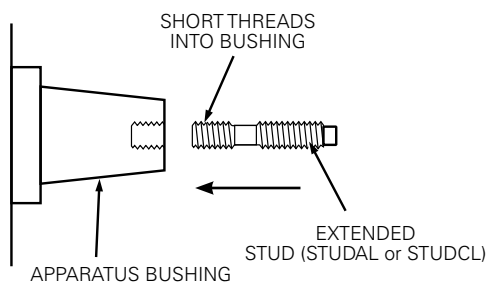

Figure 25. Line illustration of bushing stud installation.

Install BT-TAP assembly onto apparatus bushing

Step 13

Install T-body onto apparatus bushing

- Clean and then lubricate mating interfaces of apparatus bushing and T-body with lubricant supplied.
- Push T-body onto apparatus bushing ensuring that the stud on the bushing passes through the hole of the compression connector. See Figure 26.

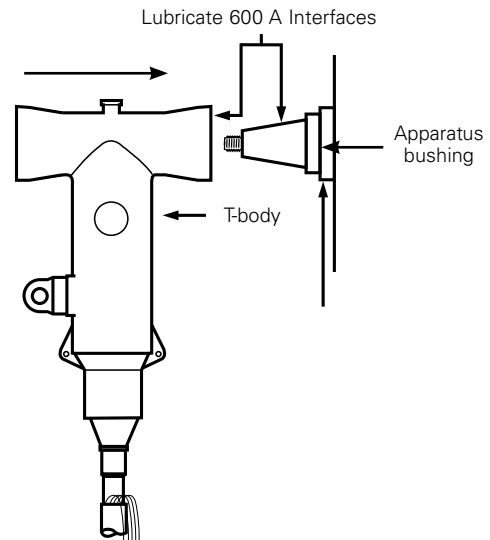

Figure 26. Line illustration of BT-TAP connector installation onto apparatus bushing.

Step 14.

Install reducing tap plug

- Clean and lubricate mating interfaces of T-Body and reducing tap plug (BLRTP).
- Insert BLRTP into back of T-body engaging the threads of the stud. See Figure 27.
- By hand, turning clockwise, thread BLRTP in as far as possible.
- Using a 3/8" drive torque tool and HD625 (5/16" hex shaft), complete threading clockwise until tight. Torque to 55 ft-lbs. See Figure 27.

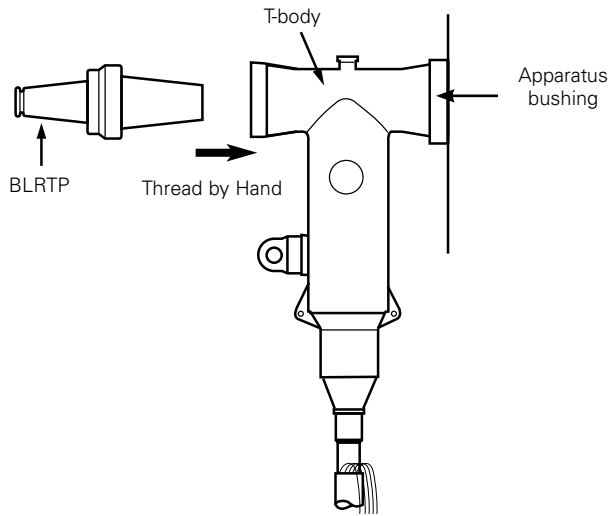

Figure 27. Line illustration of BLRTP installation.

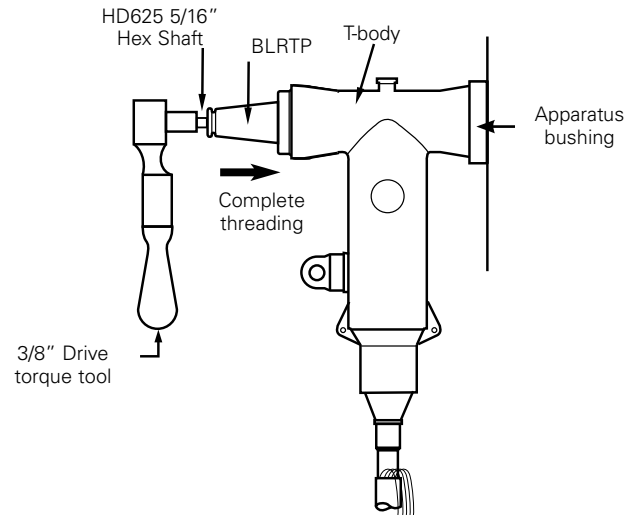

Figure 28. Line illustration of tightening termination.

Step 15.

Check tightness of termination

- Check tightness by hand by moving T-body forward and back (perpendicular to the apparatus frontplate). Do not move side to side as this may loosen the connection.
- If tight:
 - Re-torque to 55 ft-lbs.
- If loose:
 - Remove BLRTP and T-body from apparatus bushing.
 - Inspect threads of the stud and BLRTP for damage. If damaged replace damaged component and re-install per previous installation instructions.
 - If no damage is found, re-install per previous installation instructions.

Step 16.**Cap the 200 A interface**

Follow the installation instructions supplied with the mating 200 A product (loadbreak elbow, M.O.V.E. arrester, etc.). Refer to Figure 29.

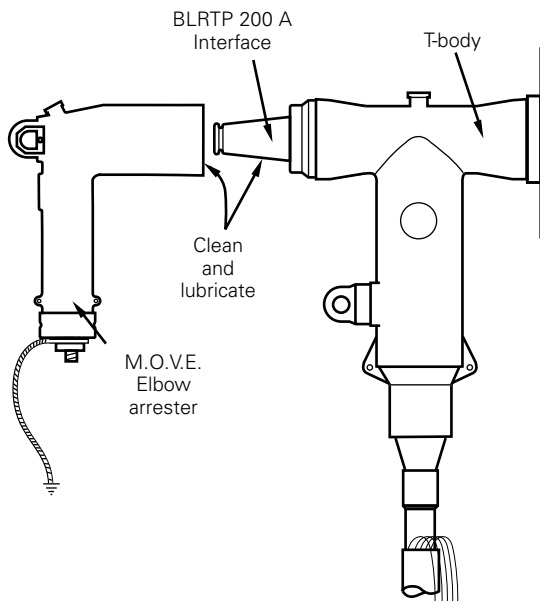

Figure 29. Line illustration of M.O.V.E. elbow arrester installation.

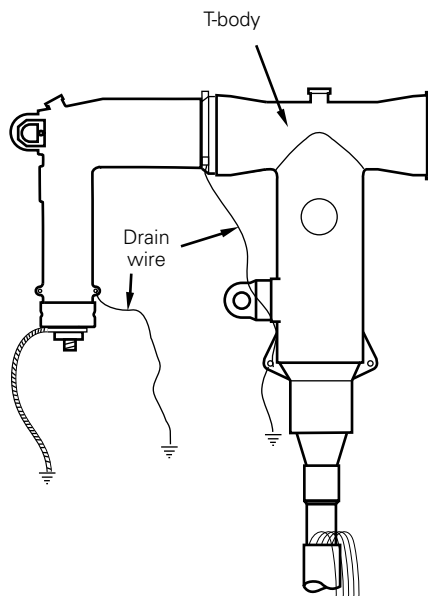

Figure 30. Installation of the drain wires.

Step 17.**Ground system**

- Connect one drain wire tab of the BLRTP and T-body with an uninsulated drain wire to a common ground point. Refer to Figure 30.
- Connect the mating 200 A product (i.e., protective cap, grounding elbow, M.O.V.E. arrester) drain wire to common ground.
- When connecting drain wires to the common ground point, be sure to leave adequate slack for hotstick operation.

This page is intentionally left blank.



Eaton
1000 Eaton Boulevard
Cleveland, OH 44122
United States
Eaton.com

Eaton's Power Systems Division
2300 Badger Drive
Waukesha, WI 53188
United States
Cooperpower.com

© 2019 Eaton
All Rights Reserved
Printed in USA
Publication No. MN650004EN
February 2019

Eaton is a registered trademark.

All trademarks are property of their
respective owners.