

600 A, 15, 25, and 35 kV Class Cleer™ Grounding Elbow Installation Instructions



DISCLAIMER OF WARRANTIES AND LIMITATION OF LIABILITY

The information, recommendations, descriptions and safety notations in this document are based on Eaton Corporation's ("Eaton") experience and judgment and may not cover all contingencies. If further information is required, an Eaton sales office should be consulted. Sale of the product shown in this literature is subject to the terms and conditions outlined in appropriate Eaton selling policies or other contractual agreement between Eaton and the purchaser.

THERE ARE NO UNDERSTANDINGS, AGREEMENTS, WARRANTIES, EXPRESSED OR IMPLIED, INCLUDING WARRANTIES OF FITNESS FOR A PARTICULAR PURPOSE OR MERCHANTABILITY, OTHER THAN THOSE SPECIFICALLY SET OUT IN ANY EXISTING CONTRACT BETWEEN THE PARTIES. ANY SUCH CONTRACT STATES THE ENTIRE OBLIGATION OF EATON. THE CONTENTS OF THIS DOCUMENT SHALL NOT BECOME PART OF OR MODIFY ANY CONTRACT BETWEEN THE PARTIES.

In no event will Eaton be responsible to the purchaser or user in contract, in tort (including negligence), strict liability or otherwise for any special, indirect, incidental or consequential damage or loss whatsoever, including but not limited to damage or loss of use of equipment, plant or power system, cost of capital, loss of power, additional expenses in the use of existing power facilities, or claims against the purchaser or user by its customers resulting from the use of the information, recommendations and descriptions contained herein. The information contained in this manual is subject to change without notice.

Contents

DISCLAIMER OF WARRANTIES AND LIMITATION OF LIABILITY	II
SAFETY FOR LIFE	IV
SAFETY INFORMATION	IV
Safety instructions	iv
PRODUCT INFORMATION	1
Introduction	1
Read this manual first	1
Additional information	1
Acceptance and initial inspection	1
Handling and storage	1
Quality standards	1
CABLE ISOLATION AND GROUNDING INSTRUCTIONS	1
Equipment required	1
Visible break and visible ground using T-OP™ II or BT-TAP™ terminations	2
Visible break and visible ground using BOL-T™ terminations	4



Safety for life



Eaton meets or exceeds all applicable industry standards relating to product safety in its Cooper Power™ series products. We actively promote safe practices in the use and maintenance of our products through our service literature, instructional training programs, and the continuous efforts of all Eaton employees involved in product design, manufacture, marketing, and service.

We strongly urge that you always follow all locally-approved safety procedures and safety instructions when working around high-voltage lines and equipment, and support our “Safety For Life” mission.

Safety information

The instructions in this manual are not intended as a substitute for proper training or adequate experience in the safe operation of the equipment described. Only competent technicians who are familiar with this equipment should install, operate, and service it.

A competent technician has these qualifications:

- Is thoroughly familiar with these instructions.
- Is trained in industry-accepted high- and low-voltage safe operating practices and procedures.
- Is trained and authorized to energize, de-energize, clear, and ground power distribution equipment.
- Is trained in the care and use of protective equipment such as arc flash clothing, safety glasses, face shield, hard hat, rubber gloves, clampstick, hotstick, etc.

Following is important safety information. For safe installation and operation of this equipment, be sure to read and understand all cautions and warnings.

Hazard Statement Definitions

This manual may contain four types of hazard statements:

DANGER

Indicates an imminently hazardous situation which, if not avoided, will result in death or serious injury.

WARNING

Indicates a potentially hazardous situation which, if not avoided, could result in death or serious injury.

CAUTION

Indicates a potentially hazardous situation which, if not avoided, may result in minor or moderate injury.

NOTICE

Indicates a potentially hazardous situation which, if not avoided, may result in equipment damage only.

Safety instructions

Following are general caution and warning statements that apply to this equipment. Additional statements, related to specific tasks and procedures, are located throughout the manual.

DANGER

Hazardous voltage. Contact with hazardous voltage will cause death or severe personal injury. Follow all locally-approved safety procedures when working around high- and low-voltage lines and equipment.

G103.3

WARNING

Before installing, operating, maintaining, or testing this equipment, carefully read and understand the contents of this manual. Improper operation, handling, or maintenance can result in death, severe personal injury, and equipment damage.

G101.0

WARNING

This equipment is not intended to protect human life. Follow all locally-approved procedures and safety practices when installing or operating this equipment. Failure to comply can result in death, severe personal injury, and equipment damage.

G102.1

WARNING

Power distribution and transmission equipment must be properly selected for the intended application. It must be installed and serviced by competent personnel who have been trained and understand proper safety procedures. These instructions are written for such personnel and are not a substitute for adequate training and experience in safety procedures. Failure to properly select, install, or maintain power distribution and transmission equipment can result in death, severe personal injury, and equipment damage.

G122.2

Product information

Introduction

The Eaton Cooper Power series Cleer™ grounding elbow (**Figure 1**) is a tool used to provide a visible ground on Eaton Cooper Power series 600 A, 15, 25, and 35 kV Cleer Loadbreak Connector Systems. It is designed to be installed directly on the 600 A loadbreak interfaces after the circuit is verified to be de-energized. A Cleer grounding elbow installed on the loadbreak bushing interfaces on each end of the cable will isolate and ground the cable. The grounding elbow has a 16 kA 10 cycle through fault rating for 15 kV systems.

All grounding elbow sets supplied with a factory installed ferrule and clamp conform to the latest requirements of ASTM F855. When grounding elbow is ordered without clamp, it does not meet ASTM F855. It is the user's responsibility to install an approved ferrule and clamp. For all kits not conforming to the latest ASTM F855 Edition, the cable will be terminated with a blunt cable end.

Read this manual first

Read and understand the contents of this manual and follow all locally approved procedures and safety practices before installing or operating this equipment

Additional information

These instructions cannot cover all details or variations in the equipment, procedures, or process described nor provide directions for meeting every possible contingency during installation, operation, or maintenance. When additional information is desired to satisfy a problem not covered sufficiently for the user's purpose, contact your Eaton representative.



Figure 1. 600 A, 15/25/35 kV Class Cleer grounding elbow shown with six feet of 600 volt fully insulated copper ground cable and clamp

Acceptance and initial inspection

Each grounding elbow is completely inspected and tested at the factory. It is in good condition when accepted by the carrier for shipment. Upon receipt of a grounding elbow, inspect the grounding elbow thoroughly for damage and loss of parts incurred during shipment. If damage or loss is discovered, file a claim with the carrier immediately.

Handling and storage

Grounding elbows and accessories should be stored and handled in a manner as to prevent contamination to the interfaces. When not in use, grounding elbows should be stored installed on a mating accessory, such as a standoff bushing.

Quality standards

ISO 9001 Certified Quality Management System

Cable isolation and grounding instructions

CAUTION

The Eaton Cooper Power series 600 A Cleer Grounded Elbow is designed to be operated in accordance with normal safe operating procedures. These instructions are not intended to supersede or replace existing safety and operating procedures. The grounding elbow should be installed and service only by personnel knowledgeable of good safety practices and fully trained on the installation and application of high voltage electrical equipment.

For product applications that require ratings or characteristics not shown, contact Eaton for specific recommendations.

Equipment required

- (2) 600 A Cleer grounding elbows
- (2) 600 A Cleer standoff bushings
- (2) 600 A Cleer insulated protective caps
- Silicone lubricant
- Clampstick
- Installation instruction sheet

Visible break and visible ground using T-OP™ II or BT-TAP™ terminations

WARNING

Visibly inspect grounding elbows, cables, ferrules, and clamps prior to installation to ensure they are complete, undamaged, and there is no corrosion or breakage. Damaged or worn grounding equipment can result in equipment failure that could cause property destruction or personal injury.

WARNING

All associated apparatus must be de-energized during installation or maintenance.

Step 1

Clean and lubricate apparatus

- Clean and lubricate interfaces of protective caps and standoff bushings using lubricant supplied or Eaton equivalent.

Step 2

Install standoff bushing

- Attach a #14 AWG copper drain wire from the standoff bracket ground lug to system ground.
- Securely fasten a clampstick to the eyebolt on standoff bushing bracket and use the clampstick to position the standoff in standoff pocket. Tighten eyebolt against apparatus wall.

Step 3

Remove “C” Connector

WARNING

High Voltage. The Cooper Power series Cleer 600 A loadbreak bushings from Eaton should only be mated with other Cleer 600 A loadbreak products. Do not attempt to mate 200 A loadbreak or 600 A deadbreak products to Cleer 600 A loadbreak bushings. Failure to comply could lead to a fault that may result in death or serious injury.

WARNING

High Voltage. Do not close or pull the Eaton Cooper Power series Cleer connector slowly onto or off of the bushings during a loadmake or loadbreak operation. Failure to comply could tease the contacts leading to excessive arcing causing a fault that may result in death or serious injury.

WARNING

High Voltage. The Eaton Cooper Power series Cleer 600 A loadbreak connector system is not designed to be switched under water. When operating the Cleer 600 A loadbreak connector system where moisture is present, such as during a rainstorm, take steps to ensure the connector interfaces stay dry. Failure to comply could lead to a fault that may result in death or serious injury.

WARNING

High Voltage. The operator should always use personal protective equipment (insulated gloves, clampstick and eye protection) whenever operating the connector. The operator should always be in the best possible operating position, providing firm footing and enabling a secure grasp of the clampstick positioned to the side of one’s torso, while maintaining positive control of the connector before, during and immediately after operation. If there is any question regarding the operator’s operating position, de-energize the connector before operation. The operator should not be looking directly at the connector during the moment of circuit interruption or connection. Failure to comply could result in death or serious injury.

- Area must be clear of obstructions or contaminants that would interfere with this operation.
- Secure connector operating eye firmly onto clampstick and lock.
- Thrust clampstick forward until the connector moves approximately 1/4" (5 mm) further onto the bushings. This action will break any surface friction between outer surfaces of bushings and inner surfaces of connector interfaces. The yellow latch indicator rings on the bushings should now be visible in the cuff windows of the connector.
- Looking away from the connector, pull the clampstick and withdraw the connector from bushings with a fast, firm, straight motion. Minimum amount of travel of connector to break load is 9" (230 mm).
- Using the clampstick, move the connector away from the bushings and place the metallic portion of one of the probes directly onto a ground plane. This will discharge any capacitive charge that may still be on the probes. Alternatively, the “C” connector can be mated directly with the Cleer standoff bushing to discharge any capacitive charge that may still be on the probe.

WARNING

High Voltage. If the fiberglass contact tube of one or both loadbreak bushing(s) extends forward, the unit MUST be replaced. Failure to comply could cause thermal runaway failure or failure to successfully fault-close; this may result in serious personal injury

- Install “C” connector on Cleer standoff bushing.

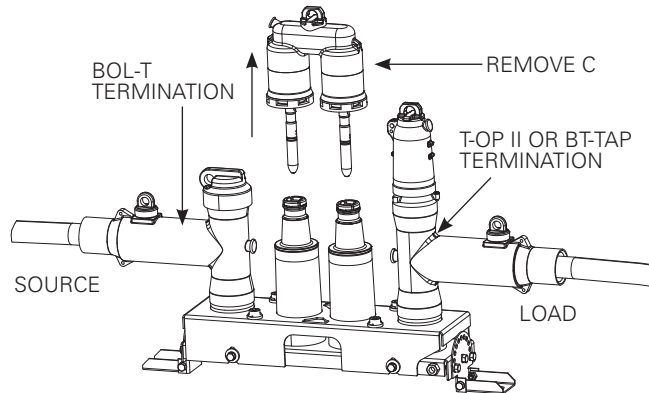

Figure 2. Remove “C” connector

Step 4

Install insulated protective cap

- Attach Cleer loadbreak protective cap drain wire to system ground.
- Using a clampstick, install a Cleer 600 A loadbreak protective cap on the source-side loadbreak bushing. See **Figure 3**.

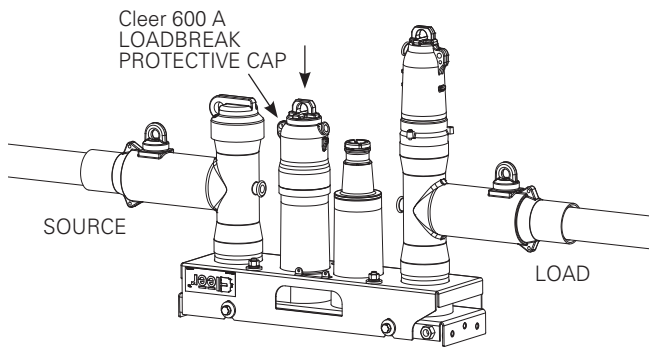

Figure 3. Install 600 A loadbreak protective cap

Step 5

Remove 200 a protective cap

- Using a clampstick, remove 200 A loadbreak protective cap from 200 A loadbreak reducing tap plug. See **Figure 4**.

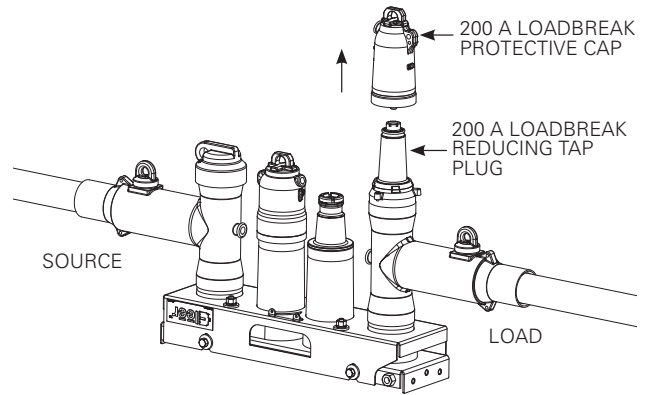

Figure 4. Remove 200 A loadbreak protective cap

Step 6

Test

WARNING

All associated apparatus must be de-energized during installation or maintenance.

WARNING

Do not ground energized cable.

- Using appropriate voltage sensing meter, test through 200 A interface to verify circuit is de-energized. See **Figure 5**.

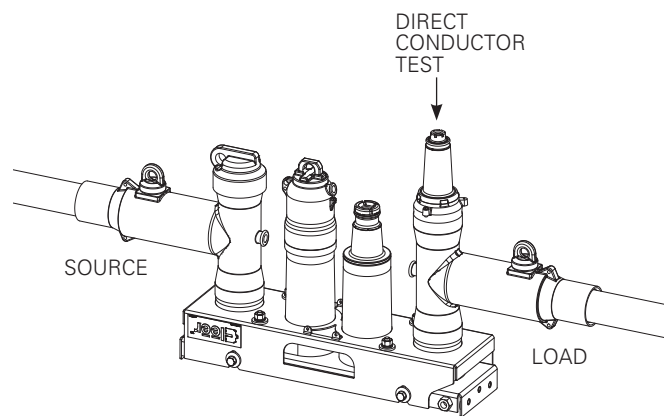

Figure 5. Verify circuit is de-energized

Step 7

Re-install 200 A protective cap

- After circuit has been verified as de-energized, using a clampstick, re-install 200 A protective cap on loadbreak reducing tap plug. See **Figure 6**.

600 A, 15, 25, and 35 kV Class Cleer™ Grounding Elbow

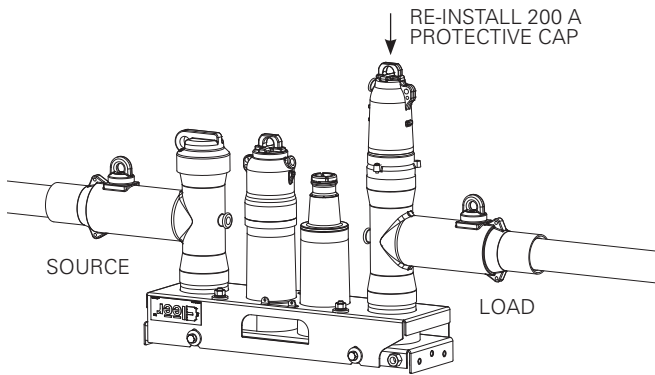

Figure 6. Re-install 200 A protective cap

Step 8

Install cleer grounding elbow

- Using a clampstick, install Cleer grounding elbow on load-side 600 A loadbreak bushing. See Figure 7.

⚠ WARNING

If the available fault current is over 16kA, you must use CLEERBAIL and CLEERCHAIN, and the grounding elbow must be equipped with 4/0 cable.

⚠ WARNING

The operator should always use personal protective equipment (insulated gloves, clampstick and eye protection) whenever operating the elbow. The operator should always be in the best possible operating position, providing firm footing and enabling a secure grasp of the clampstick, while maintaining positive control of the elbow before, during and immediately after operation. If there is any question regarding the operator's operating position, de-energize the elbow before operation. The operator should not be looking directly at the connector during the moment of circuit interruption or connection. Failure to comply could result in death or serious injury.

- Area must be clear of obstructions or contaminations that would interfere with the operation of the loadbreak elbow.
- Securely fasten a clampstick to the pulling eye of the grounding elbow.
- Place the grounding elbow over the bushing, inserting the white arc follower of the probe into the bushing approximately 1-1/2" (38 mm) until a slight resistance is felt. This will align and stabilize the elbow.
- Turn your back to the bushing and grasp the clampstick securely and obtain good footing. Slam the elbow onto the bushing with one quick and continuous motion.

- Turn around and apply a force to the clampstick to push the elbow onto the bushing. A popping or snapping sound is often heard when this operation is performed.
- To check that the elbow is properly latched apply a gentle pull force to the clampstick. When latched properly the elbow will not slide back off of the bushing.
- As a last operation, push on the clampstick to seat the elbow all the way onto the bushing again. This insures that the elbow is latched and was not dislodged during the latching check in previous step above.

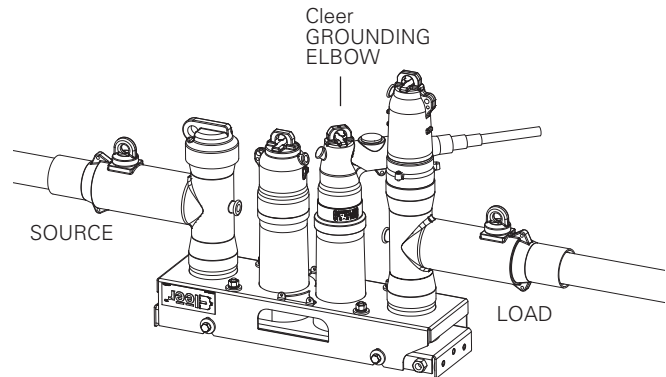

Figure 7. Install Cleer grounding elbow

Step 9

Repeat process

⚠ CAUTION

This procedure must be performed on both ends of the cable for complete grounding.

- Repeat Step 1 through Step 8 on the opposite end of the cable.

Visible break and visible ground using BOL-T™ terminations

⚠ WARNING

Visibly inspect grounding elbows, cables, ferrules, and clamps prior to installation to ensure they are complete, undamaged, and there is no corrosion or breakage. Damaged or worn grounding equipment can result in equipment failure that could cause property destruction or personal injury.

⚠ WARNING

All associated apparatus must be de-energized during installation or maintenance.

Step 1

Clean and lubricate apparatus

- Clean and lubricate interfaces of protective caps and standoff bushings using lubricant supplied or Eaton equivalent.

Step 2

Install standoff bushing

- Attach a #14 AWG copper drain wire from the standoff bracket ground lug to system ground.
- Securely fasten a clampstick to the eyebolt on standoff bushing bracket and use the clampstick to position the standoff in standoff pocket. Tighten eyebolt against apparatus wall.

Step 3

Remove “C” connector

⚠ WARNING

The operator should always use personal protective equipment (insulated gloves, clampstick and eye protection) whenever operating the elbow. The operator should always be in the best possible operating position, providing firm footing and enabling a secure grasp of the clampstick, while maintaining positive control of the elbow before, during and immediately after operation. If there is any question regarding the operator’s operating position, de-energize the elbow before operation. The operator should not be looking directly at the connector during the moment of circuit interruption or connection. Failure to comply could result in death or serious injury.

⚠ WARNING

High Voltage. Cooper Power series Cleer 600 A loadbreak bushings from Eaton should only be mated with other Cleer 600 A loadbreak products. Do not attempt to mate 200 A loadbreak or 600 A deadbreak products to Cleer 600 A loadbreak bushings. Failure to comply could lead to a fault that may result in death or serious injury.

⚠ WARNING

High Voltage. Do not close or pull the Eaton Cooper Power series Cleer connector slowly onto or off of the bushings during a loadmake or loadbreak operation. Failure to comply could tease the contacts leading to excessive arcing causing a fault that may result in death or serious injury.

⚠ WARNING

High Voltage. The Eaton Cooper Power series Cleer 600 A loadbreak connector system is not designed to be switched under water. When operating the Cleer 600 A loadbreak connector system where moisture is present, such as during a rainstorm, take steps to ensure the connector interfaces stay dry. Failure to comply could lead to a fault that may result in death or serious injury.

- Area must be clear of obstructions or contaminants that would interfere with this operation.
- Secure connector operating eye firmly onto clampstick and lock.
- Thrust clampstick **forward** until the connector moves approximately 1/4" (5 mm) further onto the bushings. This action will break any surface friction between outer surfaces of bushings and inner surfaces of connector interfaces. The yellow latch indicator rings on the bushings should now be visible in the cuff windows of the connector.
- Looking away from the connector, pull the clampstick and withdraw the connector from bushings with a fast, firm, straight motion. Minimum amount of travel of connector to break load is 9" (230 mm).
- Using the clampstick, move the connector away from the bushings and place the metallic portion of one of the probes directly onto a ground plane. This will discharge any capacitive charge that may still be on the probes.

⚠ WARNING

High Voltage. If the fiberglass contact tube of one or both loadbreak bushing(s) extends forward, the unit **MUST** be replaced. Failure to comply could cause thermal runaway failure or failure to successfully fault-close.

- Install “C” connector on Cleer standoff bushing.

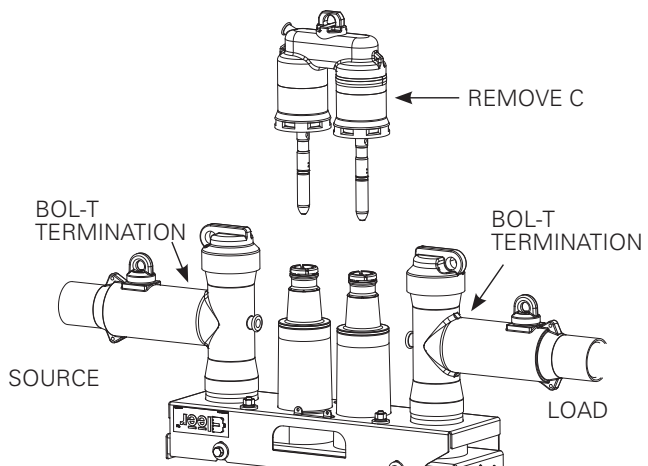

Figure 8. Remove “C” connector

600 A, 15, 25, and 35 kV Class Cleer™ Grounding Elbow

Step 4

Install insulated protective cap

- Attach Cleer loadbreak protective cap drain wire to system ground.
- Using a clampstick, install a Cleer 600 A loadbreak protective cap on the source-side loadbreak bushing. See **Figure 9**.

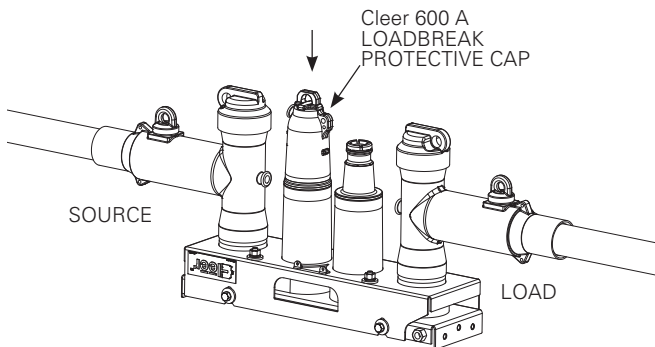

Figure 9. Install Cleer 600 A loadbreak protective cap

Step 5

Test

- Using an appropriate voltage sensing meter, test through the load side 600 A loadbreak bushing interface to verify circuit is de-energized. See **Figure 10**.

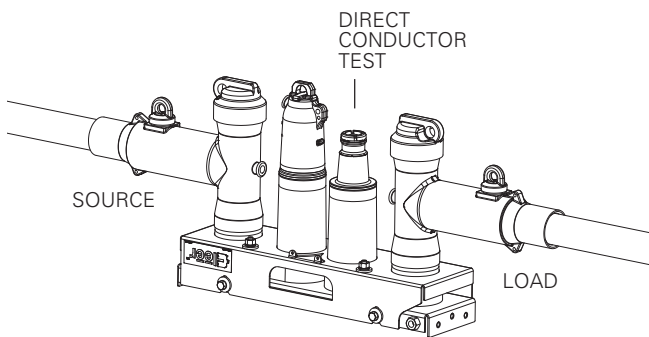

Figure 10. Verify circuit is de-energized

Step 6

Install grounding elbow

⚠ WARNING

All associated apparatus must be de-energized during installation or maintenance.

⚠ WARNING

Do not ground energized cable.

- If circuit is de-energized, install Cleer 600 A, 15/25/35 kV grounding elbow cable to system ground. Install grounding elbow on load-side 600 A loadbreak interface. See **Figure 11**.

⚠ WARNING

If the available fault current is over 16kA, you must use CLEERBAIL and CLEERCHAIN, and the grounding elbow must be equipped with 4/0 cable.

⚠ WARNING

The operator should always use personal protective equipment (insulated gloves, clampstick and eye protection) whenever operating the elbow. The operator should always be in the best possible operating position, providing firm footing and enabling a secure grasp of the clampstick, while maintaining positive control of the elbow before, during and immediately after operation. If there is any question regarding the operator's operating position, de-energize the elbow before operation. The operator should not be looking directly at the connector during the moment of circuit interruption or connection. Failure to comply could result in death or serious injury.

- Area must be clear of obstructions or contaminations that would interfere with the operation of the loadbreak elbow.
- Securely fasten a clampstick to the pulling eye of the grounding elbow.
- Place the grounding elbow over the bushing, inserting the white arc follower of the probe into the bushing approximately 1-1/2" (38 mm) until a slight resistance is felt. This will align and stabilize the elbow.
- Turn your back to the bushing and grasp the clampstick securely and obtain good footing. Slam the elbow onto the bushing with one quick and continuous motion.
- Turn around and apply a force to the clampstick to push the elbow onto the bushing. A popping or snapping sound is often heard when this operation is performed.
- To check that the elbow is properly latched apply a gentle pull force to the clampstick. When latched properly the elbow will not slide back off of the bushing.

- As a last operation, push on the clampstick to seat the elbow all the way onto the bushing again. This insures that the elbow is latched and was not dislodged during the latching check in previous step above.

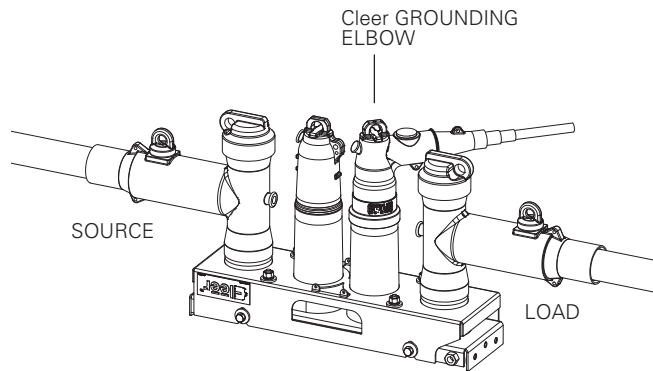

Figure 11. Install Cleer grounding elbow

Step 7

Repeat process



This procedure must be performed on both ends of the cable for complete grounding.

- Repeat Step 1 through Step 6 on the opposite end of the cable.



Eaton
1000 Eaton Boulevard
Cleveland, OH 44122
United States
Eaton.com

Eaton's Power Systems Division
2300 Badger Drive
Waukesha, WI 53188
United States
Eaton.com/cooperpowerseries

© 2020 Eaton
All Rights Reserved
Printed in USA
Publication No. MN650056EN
February 2020

Eaton is a registered trademark.

All trademarks are property
of their respective owners.

For Eaton's Cooper Power series product
information, call 1-877-277-4636 or visit:
www.eaton.com/cooperpowerseries.