

400 A deadbreak plug-in tee connector - interface B



DT400P – 24 kV applications

DT436P – 36 kV applications

Related products

- DPC400 Connecting Plug
- DRC400 Receptacle Cap

Installation

- No special tools, heating, taping, or potting are required
- Connector may be energized immediately after installation on its mating part
- Mates with bushings, plugs, and junction devices complying with interface B per Cenelec 50180 and 50181

Application

- For connection of extruded polymeric cable to transformers, switchgear, motors and other equipment with a premoulded separable connector
- For indoor and outdoor installations
- System voltage up to 36 kV
- Continuous current 400 A (600 A overload for 8 hours)
- Cable particulars:
 - Extruded polymeric cable (XLPE, EPR, etc.)
 - Copper or aluminum conductors
 - Semiconducting or metallic screens
- Conductor size: 12 kV 70-400 mm²
24 kV 25-400 mm²
36 kV 25-240 mm²

Features

- Provides a fully screened and fully submersible separable connection when mated with the proper bushing or plug
- Built-in capacitive test point allows for an easy check of the circuit status or installation of a fault indicator
- No minimum phase clearance requirements
- Mounting can be vertical, horizontal, or any angle in between
- 100% factory tested

Standards

- Meets the requirements of IEC 60502-4 and CENELEC HD 659.1 S2

EATON

Powering Business Worldwide

Quality assurance

- Our manufacturing facility is registered to ISO 9001 by third party audit
- Required Production Tests
- Periodic X-Ray Analysis

Packaging

- Supplied in a kit with all necessary parts, approximate weight 3 kg

Features and detailed description

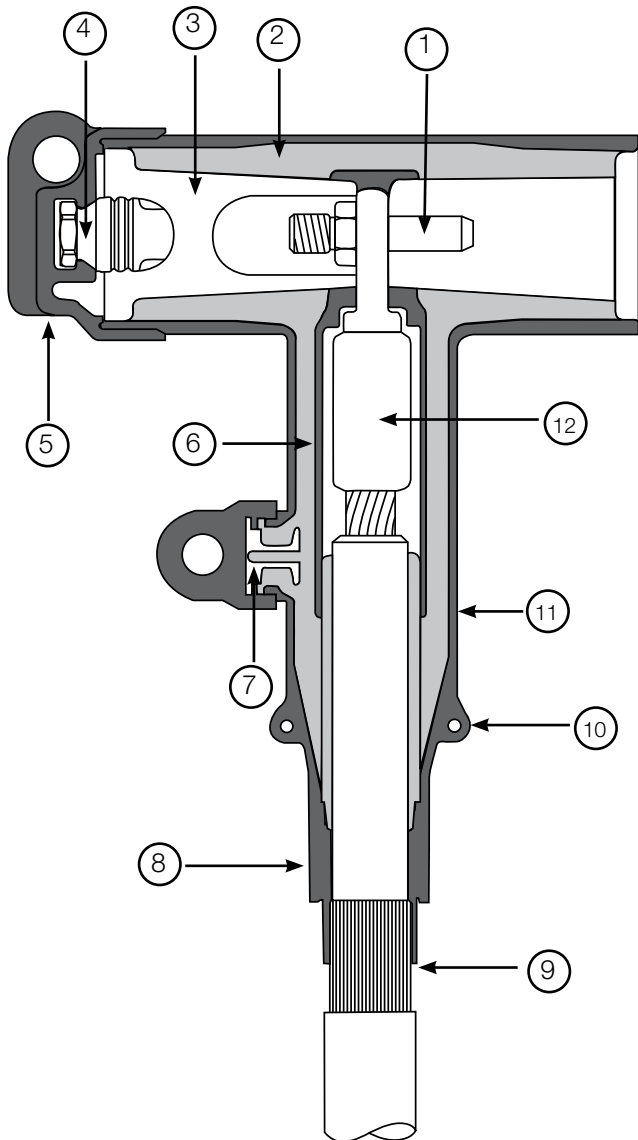

Table 1. Electrical Rating

	DT400P	DT436P
Maximum System Voltage (U_m)	24 kV	36 kV
Impulse	125 kV	170 kV
AC Withstand (5 min.)	54 kV	81 kV
Continuous Current	400 A	400 A
Overload (8 hrs. Max.)	600 A	600 A
Short Circuit Withstand, 1 sec. (rms sym)	18 kA	18 kA

Notes: Ratings are based on IEC Standards and do not reflect maximum capability.

- 1. Pin Contact**
Tin-plated copper contact screws into the conductor contact
- 2. Insulation**
Moulded EPDM insulating rubber is formulated and mixed in our facility in the USA to ensure high quality
- 3. Basic Insulating Plug**
Moulded epoxy part has a threaded metal insert to accept the pin contact
- 4. Capacitive Test Point**
Capacitive test point provides means to check circuit status. A moulded EPDM conducting rubber cap provides a watertight seal.
- 5. Rubber Cap**
Moulded EPDM conducting rubber cap protects and earths the test point during normal operation
- 6. Internal Screen**
Moulded EPDM conducting rubber screen controls electrical stress
- 7. Capacitive Test Point (Optional)**
Provides a means to mount a fault indicator. A moulded EPDM conducting rubber cap provides a watertight seal.
- 8. Stress Relief**
The configuration of the outer screen and the cable adapter provides cable stress relief
- 9. Cable Adapter**
The sized opening provides an interference fit to maintain a watertight seal and provides the initial cable stress relief
- 10. Earthing Eyes**
Moulded into the external screen for connection of an earthing wire
- 11. External Screen**
Moulded EPDM conducting rubber mates with the cable screen to maintain screen continuity and ensure that the assembly is at earth potential
- 12. Conductor Contact**
Inertia welded bimetallic compression connector accepts copper or aluminum conductors

Figure 2.
400 A, 36 kV Class DT400P Deadbreak Tee Connector.

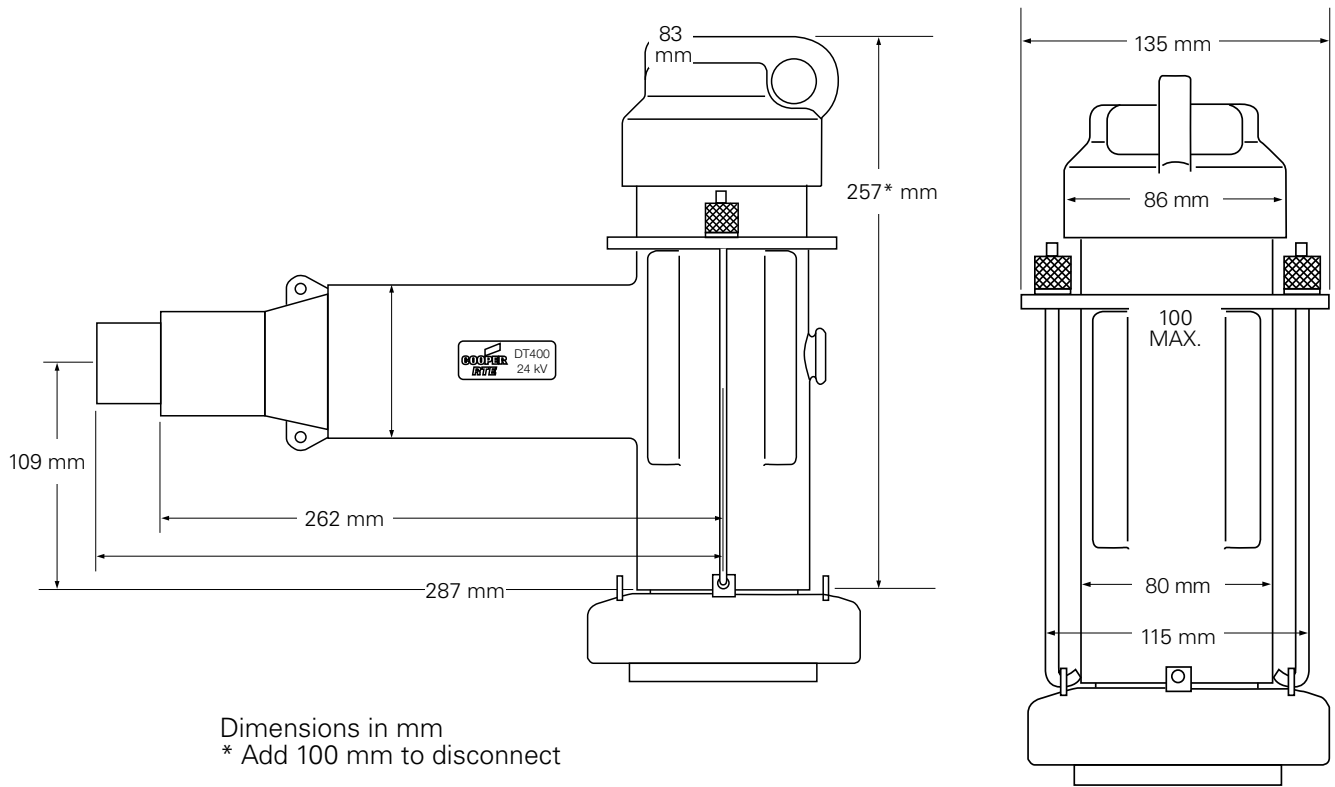

Figure 3. DT400P Deadbreak Tee Connector dimensional information.

Ordering information

For 12 kV and 24 kV applications, the ordering formula is DT400P-R-C. For 36 kV applications, the ordering formula is DT436P-R-C. Substitute the R and C as described below. Select the range from Table 2 that best fits the diameter of the core insulation. Select the code from Table 3 for the conductor size and type of connector required.

Table 2. Cable Insulation Range

Insulation Range Designation	Cable Insulation Range Ø (mm)	
	Min.	Max.
A	16.3	19.3
B	18.3	21.0
C	20.0	24.1
D	23.1	27.0
E	25.6	29.0
F	27.7	32.6
G	30.9	36.2
H	34.0	39.5

Optional Test Point

If a test point on the tee body is required, add a "T" before the insulation range designation.

Example: DT400PTF240

Ordering Example: For 20 kV cable, 240 mm² aluminum conductor, 31.0 mm core insulation diameter, DIN connector, specify DT400PF240.

Cable seal adapters are ordered separately.

Table 3. Conductor Code

Stranded Conductor Size (mm ²)	DIN Type	EDF Type
25	25	E25
35	35	E35
50	50	E50
70	70	E70
95	95	E95
120	120	E120
150	150	E150
185	185	E185
240	240	E240
300	300	-
400	400	-

Note: Bimetallic connectors can be used with aluminum or copper conductors.

Eaton
1000 Eaton Boulevard
Cleveland, OH 44122
United States
Eaton.com

Eaton's Cooper Power Systems Division
2300 Badger Drive
Waukesha, WI 53188
Eaton.com/cooperpowerseries

© 2015 Eaton
All Rights Reserved
Printed in USA
Publication No. CA650026EN

Eaton and Cooper Power are valuable trademarks of Eaton in the U.S. and other countries. You are not permitted to use these trademarks without the prior written consent of Eaton.



Powering Business Worldwide