

35 kV Class M.O.V.E. DirectConnect™ elbow arrester



General

Eaton's Cooper Power™ series M.O.V.E. DirectConnect™ elbow arrester combines metal (zinc) oxide varistor technology in a premolded rubber elbow to provide overvoltage system protection in an insulated, fully shielded, submersible, deadfront device.

The arrester housing interface conforms to IEEE Std 386™-2006 standard – Separable Insulated Connector Systems. The arrester housing is molded of EPDM insulating rubber, which provides deadfront safety in a small, clampstick operable unit.

M.O.V.E. DirectConnect elbow arresters are used on underground systems in pad-mounted transformer and entry cabinets, vaults, switching enclosures and other installations to provide shielded deadfront arrester protection. They are designed for use with 600 A 35 kV Class deadbreak interfaces that conform to IEEE Std 386™-2006 standard to limit overvoltages to acceptable levels, protect equipment and extend cable life.

EAT•N

Powering Business Worldwide

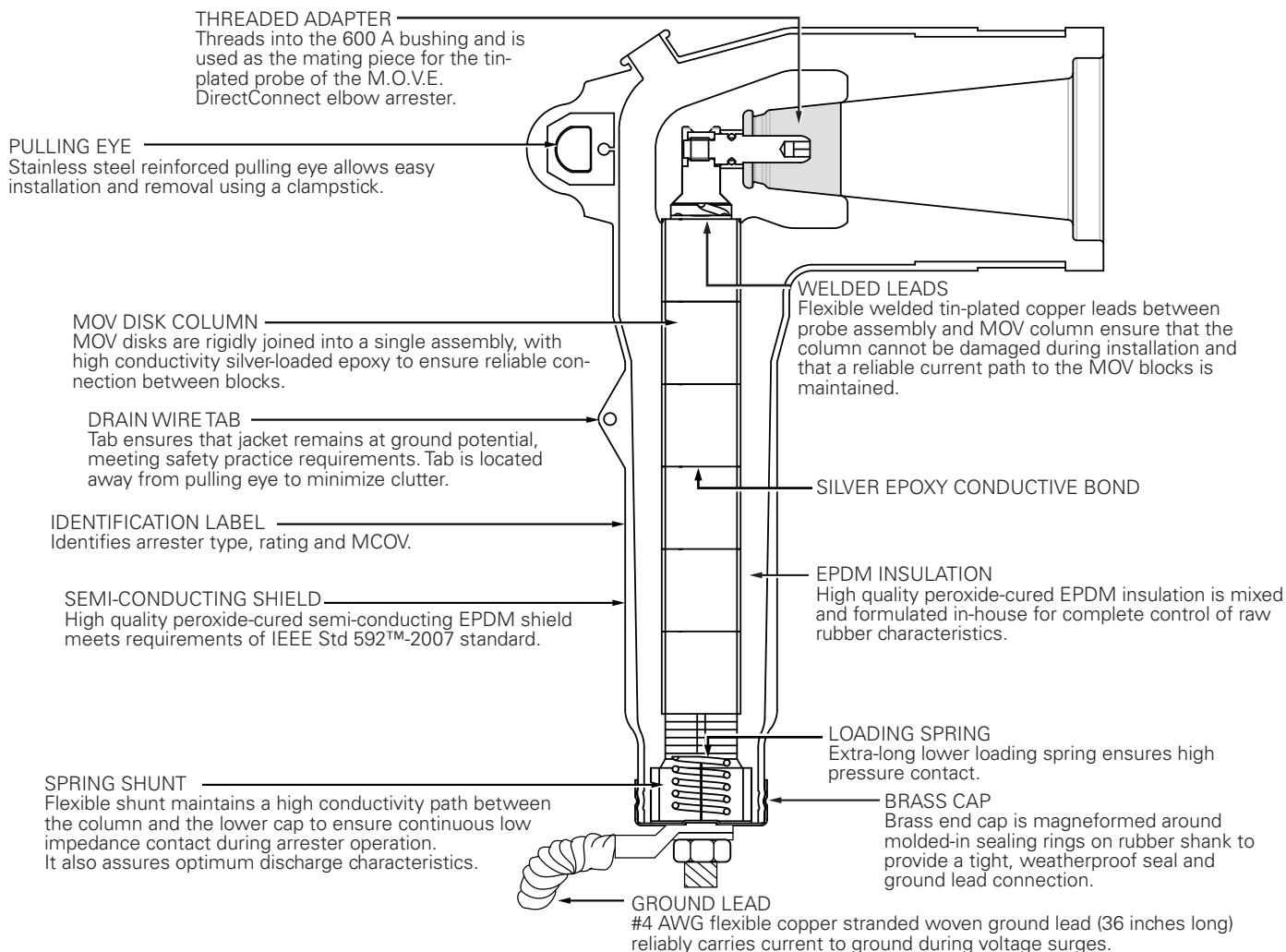

Figure 1. Cutaway illustration shows 35 kV Class M.O.V.E. DirectConnect elbow arrester.

Construction

The rubber body is constructed of high quality precision molded peroxide-cured EPDM insulation and semi-conductive materials.

The copper alloy probe and probe retainer are connected to the MOV block stack via welded flexible tin-plated copper leads. This ensures that the column cannot be damaged during installation and that a reliable current path to the MOV blocks is maintained. The disk column is composed of MOV disks bonded together with high-conductivity, silver-loaded epoxy to yield the most reliable electrical connection and eliminate air voids. The #4 AWG flexible copper ground lead, which reliably carries current to ground during voltage surges, is attached to the housing by a brass magneformed end cap. The brass end cap provides a tight, weatherproof seal.

Operation

Installing a M.O.V.E. DirectConnect elbow arrester at the end of a radial system or at both ends of an open point on a loop system provides excellent overvoltage protection.

Standards

The M.O.V.E. DirectConnect elbow arrester complies with the latest revisions of IEEE Std C62.11™ standard "IEEE Standard for Metal Oxide Surge Arresters for AC Power Circuits" and IEEE Std 386™-2006 standard "Separable Insulated Connectors for Power Distribution Systems Above 600 Volts."

Installation

All M.O.V.E. DirectConnect elbow arresters must be installed on or removed from de-energized systems. No special tools are required. An adapter is threaded into the 600 A apparatus bushing. The M.O.V.E. DirectConnect elbow arrester is then placed on the 600 A apparatus bushing using a clampstick. Refer to *Service Information MN235002EN, 35 kV Class M.O.V.E. DirectConnect Elbow Arrester Installation Instructions* for more details.

Production tests

Tests conducted in accordance with IEEE Std 386™-2006 and IEEE Std C62.11™ standards:

- Partial discharge extinction voltage level
- AC 60 Hz 1 Minute withstand
- AC 60 Hz Watts Loss

Tests conducted in accordance with Eaton requirements:

- Physical inspection
- Periodic dissection
- Arrester assembly:
 - Voltage at 1 mA
- Periodic fluoroscopic analysis

Production tests of mov blocks

A complete production test program ensures a quality product. Each metal oxide varistor receives a series of electrical tests. Quality is demonstrated by a series of destructive tests performed on every batch of varistors. Listed are the tests performed on the varistors:

- 100% Physical inspection
- 100% Discharge voltage test
- 100% V1mA/cm²
- 100% Leakage current at 80% of V1mA/cm² Voltage (Watts loss)
- Batch High-current, Short-duration test
- Batch thermal stability test
- Batch aging test

General application recommendations

The rating of an arrester is the maximum power frequency line-to-ground voltage at which the arrester is designed to pass an operating duty-cycle test. Table 2 provides a general application guide for the selection of the proper arrester rating for a given system voltage and system grounding configuration as outlined in the IEEE Std C62.22™ standard application guide.

Under fault conditions and other system anomalies, higher voltages can be experienced by the arrester. To ensure that the arrester ratings will not be exceeded, Eaton application engineers are available to make recommendations. The following information is normally required:

1. System maximum operating voltage.
2. System grounding conditions.
 - A. For four-wire circuits, grounding conditions depend upon whether the system is multi-grounded, whether it has a neutral impedance and whether common primary and secondary neutrals are used.
 - B. For three-wire circuits, grounding conditions depend upon whether the system is solidly grounded at the source, grounded through neutral impedance at the source transformers or ungrounded.

Consult your Eaton representative to have your individual system application needs studied.

Protective characteristics

The protective characteristics of the M.O.V.E. DirectConnect elbow arrester is shown in Table 1.

Table 1. Electrical ratings and characteristics

Duty cycle voltage rating (kV)	MCOV (kV)	Equivalent front-of-wave (kV crest)*	Maximum discharge voltage (kV crest) 8/20 μs Current wave				
			1.5 kA	3 kA	5 kA	10 kA	20 kA
27	22.0	87.2	71.4	76.9	82.4	90.1	103.0
30	24.4	97.1	79.5	85.7	91.8	100.0	115.0
33	27.0	108.0	87.8	95.1	102.0	112.0	127.0
36	29.0	116.0	95.3	103.0	110.0	120.0	137.0

* Equivalent front-of-wave voltage is the expected discharge voltage of the arrester when tested with a 5 kA current surge cresting in 0.5 μs.

Table 2. Commonly applied voltage ratings of M.O.V.E. DirectConnect elbow arrester

System voltage (kV rms)	Commonly applied arrester Duty-cycle (MCOV) Voltage rating (kV rms) on Distribution systems			
	Nominal voltage (kV)	Maximum voltage range B (kV)	4-Wire Multigrounded neutral Wye	3-Wire Low Impedance grounded ¹
24.94 Y/14.4	26.4 Y/15.24	18 (15.3)	27 (22.0)	–
27.6 Y/15.93	29.255 Y/16.89	21 (17.0)	30 (24.4)	–
34.5 Y/19.92	36.51 Y/21.1	27 (22.0)	36 (29.0)	–
46 Y/26.6	48.3 Y/28	36 (29)	–	–

1. Line-to-ground fault duration not to exceed 30 minutes. For longer durations, contact the factory for proper rating.

Temporary overvoltage (TOV) capability

The Temporary Overvoltage (TOV) capability of the M.O.V.E. DirectConnect elbow arrester is shown in Figure 2.

Performance test characteristics

The M.O.V.E. DirectConnect elbow arrester consistently withstands the following design tests as described by IEEE Std C62.11™ standard:

- **Duty cycle:**
22 current surges of 5 kA crest 8/20 μs waveshape.
- **High-Current, Short-duration discharge:**
2 current surges of 40 kA crest 4/10 μs waveshape.
- **Low-Current, Long-duration discharge:**
20 current surges of 75 A crest 2000 μs rectangular wave duration.

Following each of these tests, the arresters remain thermally stable as verified by:

- Continually decreasing power values during a thirty minute power monitoring period.
- No evidence of physical or electrical deterioration.

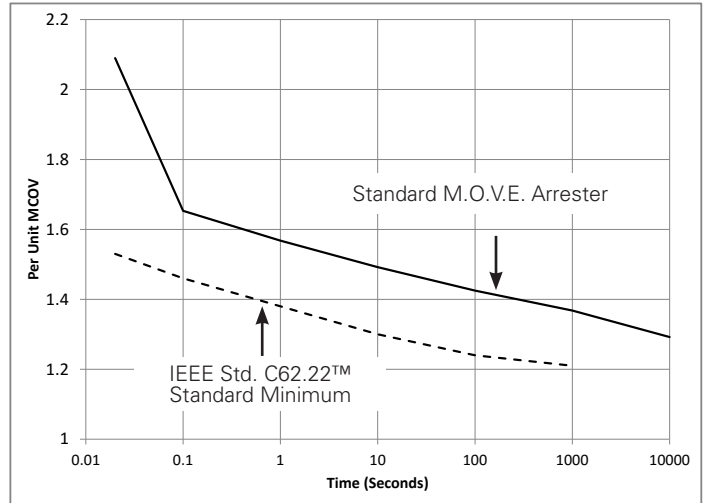
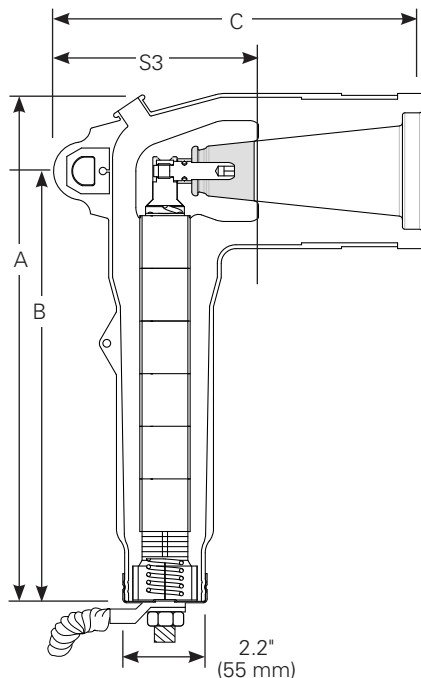

Figure 2. Temporary overvoltage curve. No prior duty at 85 °C ambient.



Voltage class	S3
35 kV	4.85" (123 mm)

Figure 3. Dimensional information of M.O.V.E. DirectConnect Elbow Arrester (refer to Table 3).

Note: Dimensions given are for reference only.

Ordering information

To order a M.O.V.E. DirectConnect elbow arrester kit, determine the arrester Maximum Continuous Operating Voltage (MCOV) rating for the intended application using Table 2 and specify the appropriate catalog number from Table 3. Contact your Eaton representative for applications not listed.

Additional information

Refer to the following reference literature for additional information:

- CA800020EN, 600 A 35 kV Class deadbreak apparatus bushing
- MN235002EN, 35 kV Class M.O.V.E. DirectConnect elbow arrester installation instructions
- PA235002EN, Directconnect product brief
- CA235025EN, Metal oxide elbow (M.O.V.E.) Surge arrester
- CT235001EN, Deadfront arresters certified test report

Table 3. M.O.V.E. DirectConnect elbow arrester selection chart

IEEE Std 386™ Standard interface	Duty Cycle (kV)	MCOV Rating (kV)	Dimensions in./.(mm)			Catalog number
			A	B	C	
35 kV Class 600 A	27	22.0	13.3 (338)	11.2 (284)	9.49 (241)	DCEA635M27
35 kV Class 600 A	30	24.4	13.3 (338)	11.2 (284)	9.49 (241)	DCEA635M30
35 kV Class 600 A	33	27.0	13.3 (338)	11.2 (284)	9.49 (241)	DCEA635M33
35 kV Class 600 A	36	29.0	13.3 (338)	11.2 (284)	9.49 (241)	DCEA635M36

This page intentionally left blank.

This page intentionally left blank.

Eaton
1000 Eaton Boulevard
Cleveland, OH 44122
United States
Eaton.com

Eaton's Power Systems Division
2300 Badger Drive
Waukesha, WI 53188
United States
Eaton.com/cooperpowerseries

© 2019 Eaton
All Rights Reserved
Printed in USA
Publication No. CA235026EN
March 2019

Eaton is a registered trademark.
All other trademarks are property
of their respective owners.

For Eaton's Cooper Power series product
information call 1-877-277-4636 or visit:
www.eaton.com/cooperpowerseries.