

## 25/35 kV class EZ™ II splice installation instructions (D, E, and F cable ranges only)



## **DISCLAIMER OF WARRANTIES AND LIMITATION OF LIABILITY**

The information, recommendations, descriptions and safety notations in this document are based on Eaton Corporation's ("Eaton") experience and judgment and may not cover all contingencies. If further information is required, an Eaton sales office should be consulted. Sale of the product shown in this literature is subject to the terms and conditions outlined in appropriate Eaton selling policies or other contractual agreement between Eaton and the purchaser.

THERE ARE NO UNDERSTANDINGS, AGREEMENTS, WARRANTIES, EXPRESSED OR IMPLIED, INCLUDING WARRANTIES OF FITNESS FOR A PARTICULAR PURPOSE OR MERCHANTABILITY, OTHER THAN THOSE SPECIFICALLY SET OUT IN ANY EXISTING CONTRACT BETWEEN THE PARTIES. ANY SUCH CONTRACT STATES THE ENTIRE OBLIGATION OF EATON. THE CONTENTS OF THIS DOCUMENT SHALL NOT BECOME PART OF OR MODIFY ANY CONTRACT BETWEEN THE PARTIES.

In no event will Eaton be responsible to the purchaser or user in contract, in tort (including negligence), strict liability or otherwise for any special, indirect, incidental or consequential damage or loss whatsoever, including but not limited to damage or loss of use of equipment, plant or power system, cost of capital, loss of power, additional expenses in the use of existing power facilities, or claims against the purchaser or user by its customers resulting from the use of the information, recommendations and descriptions contained herein. The information contained in this manual is subject to change without notice.

# Contents

## SAFETY INFORMATION

Safety Information .....	iv
--------------------------	----

## PRODUCT INFORMATION

Introduction .....	1
Acceptance and Initial Inspection .....	1
Handling and Storage .....	1
Standards .....	1

## INSTALLATION

Kit Contents .....	1
Tools/Accessories needed .....	1
Preparation of Cables to be Spliced .....	2
Splice Installation .....	3



## Safety for life



Eaton meets or exceeds all applicable industry standards relating to product safety with its Cooper Power™ series products. We actively promote safe practices in the use and maintenance of our products through our service literature, instructional training programs, and the continuous efforts of all Eaton employees involved in product design, manufacture, marketing, and service.

We strongly urge that you always follow all locally approved safety procedures and safety instructions when working around high voltage lines and equipment, and support our “Safety For Life” mission.

## Safety information

The instructions in this manual are not intended as a substitute for proper training or adequate experience in the safe operation of the equipment described. Only competent technicians who are familiar with this equipment should install, operate, and service it.

A competent technician has these qualifications:

- Is thoroughly familiar with these instructions.
- Is trained in industry-accepted high and low-voltage safe operating practices and procedures.
- Is trained and authorized to energize, de-energize, clear, and ground power distribution equipment.
- Is trained in the care and use of protective equipment such as arc flash clothing, safety glasses, face shield, hard hat, rubber gloves, clampstick, hotstick, etc.

Following is important safety information. For safe installation and operation of this equipment, be sure to read and understand all cautions and warnings.

### Hazard Statement Definitions

This manual may contain four types of hazard statements:

#### **DANGER**

**Indicates an imminently hazardous situation which, if not avoided, will result in death or serious injury.**

#### **WARNING**

**Indicates a potentially hazardous situation which, if not avoided, could result in death or serious injury.**

#### **CAUTION**

**Indicates a potentially hazardous situation which, if not avoided, may result in minor or moderate injury.**

**CAUTION:** Indicates a potentially hazardous situation which, if not avoided, may result in equipment damage only.

### Safety instructions

Following are general caution and warning statements that apply to this equipment. Additional statements, related to specific tasks and procedures, are located throughout the manual.

#### **DANGER**

**Hazardous voltage. Contact with hazardous voltage will cause death or severe personal injury. Follow all locally approved safety procedures when working around high- and low-voltage lines and equipment.**

G103.3

#### **WARNING**

**Before installing, operating, maintaining, or testing this equipment, carefully read and understand the contents of this manual. Improper operation, handling or maintenance can result in death, severe personal injury, and equipment damage.**

G101.0

#### **WARNING**

**This equipment is not intended to protect human life. Follow all locally approved procedures and safety practices when installing or operating this equipment. Failure to comply can result in death, severe personal injury and equipment damage.**

G102.1

#### **WARNING**

**Power distribution and transmission equipment must be properly selected for the intended application. It must be installed and serviced by competent personnel who have been trained and understand proper safety procedures. These instructions are written for such personnel and are not a substitute for adequate training and experience in safety procedures. Failure to properly select, install or maintain power distribution and transmission equipment can result in death, severe personal injury, and equipment damage.**

G122.3

## Product information

### Introduction

Eaton manufactures its Cooper Power™ series EZ™ II splice in accordance with IEEE Std 404™-1993 standard for cable joints.

The splice provides a permanent, fully-shielded, fully-submersible cable joint. The EPDM peroxide-cured rubber provides a highly reliable cable joint that can be used for the repair or extension of underground feeders in direct burial, conduit, or vault applications.

The splice is designed to accept wide cable ranges. The 3" long aluminum compression connector is sized to ensure maximum current transfer and a cool running connection. The connector is a field proven design that accepts copper or aluminum conductors.

### Read this manual first

Read and understand the contents of this manual and follow all locally approved procedures and safety practices before installing or operating this equipment.

### Additional information

These instructions cannot cover all details or variations in the equipment, procedures, or process described nor provide directions for meeting every possible contingency during installation, operation, or maintenance. For additional information, contact your Eaton representative.

### Acceptance and initial inspection

Each splice is in good condition when accepted by the carrier for shipment. Upon receipt, inspect the shipping container for signs of damage. Unpack the splice and inspect it thoroughly for damage incurred during shipment. If damage is discovered, file a claim with the carrier immediately.

### Handling and storage

Be careful during handling and storage of the splice to minimize the possibility of damage. If the splice is to be stored for any length of time prior to installation, provide a clean, dry storage area.

### Standards

ISO 9001 Certified Quality Management System

## Installation

Installation requires standard cable stripping and crimp tools. After cables are prepared, the splice body is positioned onto cable #1 of the prepared cables.

The conductors are then crimped together with the supplied compression connector. The splice body is then centered using the raised areas on the cable entrances as centering guides.

Tie off a concentric neutral to the drain wire tab on each side of the splice and jumper the concentric neutral wires across the splice body, using the appropriate crimp connector. (A jacketed concentric neutral cable may require jacket replacement across the splice.)

### Complete splice kit includes:

- Splice Body
- Compression Connector
- Silicone Lubricant
- Installation Instructions

### Tool/accessories needed:

- Tape Measure
- Wire Brush
- Knife
- Cable Stripping Tool
- Crimping Tool
- Cable Cleaner
- Cable Cutters
- Emery Cloth
- Tape
- Hand File
- Lint-free Cloths

## Preparation of cables to be spliced

### Step 1

Overlap both cables.

Locate the splice centerline as shown in Figure 1.

On cable #2 measure out 24" from the splice centerline and cut off the cable. (This will ensure there is an adequate length of concentric neutral wire to reconnect the neutral after splice installation.)

Cut off cable #1 at the splice centerline with a smooth square cut.

Remove the outer jacket of cable #2 to 31-3/4" (807 mm) and remove the outer jacket of cable #1 to 16" (406 mm).

Fold back the concentric neutral wires.

Cut off cable #2 at the splice centerline with a smooth square cut.

Check the jacket strip back dimensions from the splice centerline to the outer jacket cutoff.

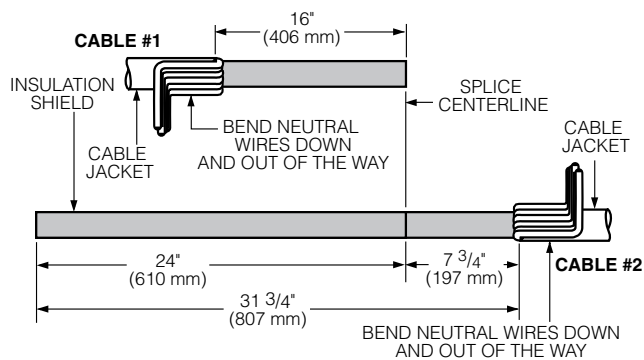

Figure 1. Illustration of cables to be spliced.

### Step 2

Measure from the end of both cables and remove 5-1/4" (133 mm) of the semi-con insulation shield (See Figure 2).

### CAUTION

Be careful not to nick or damage the cable insulation during this step.

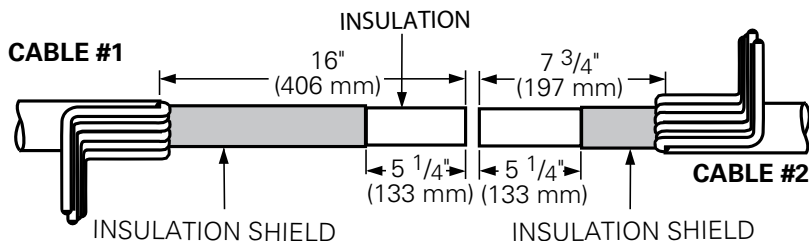

Figure 2. Insulation shield stripback.

### Step 3

Measure back from the end of both cables and remove 1-5/8" (41 mm) of the cable insulation and conductor shield, exposing the bare conductor. Remove sharp edge of insulation by beveling at 45° angle for approximately 1/8" (3 mm) (See Figure 3).

Clean the cable insulation with an approved cleaner. Wipe the cleaner towards the insulation shield only.

### CAUTION

Take care not to damage the conductor during this step.

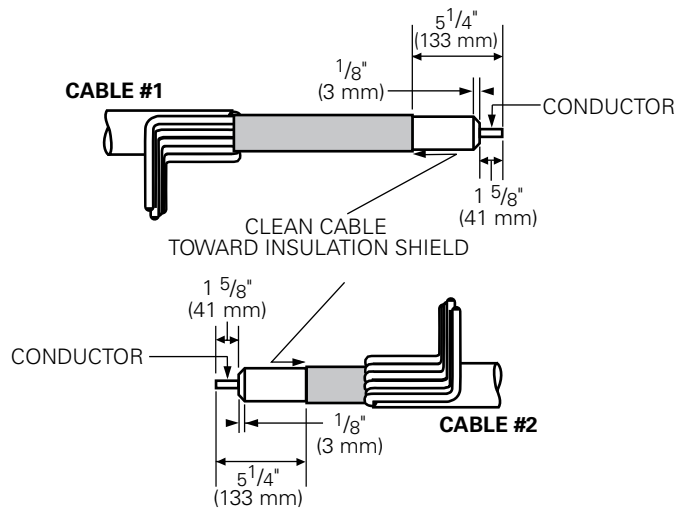

Figure 3. Insulation stripback.

## Splice installation

### Step 4

If a cable re-jacketing sleeve is used, slide it all the way on cable #1 and push it out of the way.

Apply one wrap of tape to the end of the conductor of cable #1. This is to protect the conductor strands and the splice bore during splice installation.

Using the supplied silicone lubricant or an approved equivalent, apply a thin uniform layer to both cables' insulation. On cable #1, apply the lubricant to both the insulation and insulation shield. On both cables, apply silicone lubricant to the edge of the insulation shield to provide a build-up or ramp from the insulation to the insulation shield.

Apply another thin layer of lubricant into both cable entrances of the splice body.

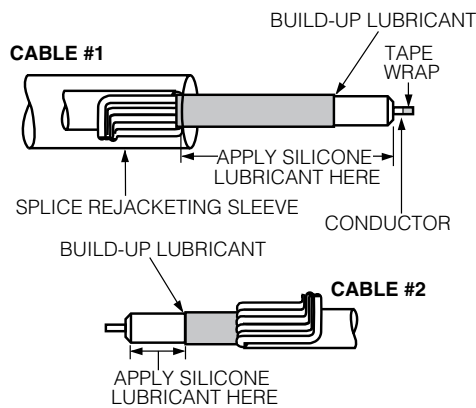

Figure 4. Cable lubrication.

### Step 5

Slide the splice body all the way on cable #1 until the bare conductor is exposed (See Figure 5). Remove tape from conductor of cable #1. Wire brush the conductor.

#### **CAUTION**

The splice body is designed to be used with a 3" long compression connector only. Use of a different length connector may cause splice failure. See Table 1.

#### **CAUTION**

The appropriate compression connector O.D. is molded into inside of the cable entrance of the splice body. Check to ensure compression connector O.D. matches that molded into the splice. Use of a different O.D. compression connector may cause splice failure. See Table 1.

Install the correct compression connector on to the conductor and crimp using an approved tool and die (See Table 2). Leave the center 1/2" of the connector uncrimped.

Start crimping from the middle with each successive crimp towards the end of the connector. Rotate each crimp 90°. Install as many crimps as possible without overlapping crimps.

**Note:** After crimping, remove any sharp edges or raised points on the compression connector using a hand file.

Clean away any excess inhibitor and filings from the compression connector. Do not wipe inhibitor on cable insulation.

Clean away any contamination from the exposed cable insulation.

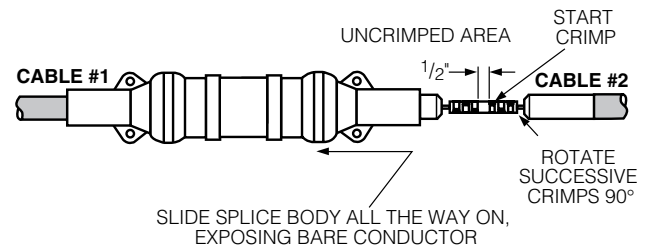

Figure 5. Compression connector installation.

Table 1. Measurement Guide

Compression Connector O.D. Measurement Guide	Compression Connector Length Guide
<p>0.91"</p> <p>0.78"</p> <p>0.64"</p>	<p>3.0"</p> <p>0.91" DIA. SHOWN</p>

**Table 2. Typical Crimping Tools**

Connector Size	Connector O. D. (Inches)	Mfg.	Tool	Die
#2 STR Thru 250 STR	0.91"	Kearney™	0	840
			H1	
			H2	840
			H3	
			H25	840
		Burndy®	MD6	W249
			MD7	
			Y35	U249ART U28RYFT
			Y45	U27RLYRT
			Blackburn®	JB12A

**Note:** Install as many crimps as possible without overlapping. Rotate each successive crimp 90° to prevent distortion.

**Step 6**

Center the splice body over the compression connector, using the raised areas on the cable entrances of the splice body as indicators (See Figure 6). Run one of the neutral wires from cable #2 through the drain wire tabs on both ends of splice as shown. Ensure neutral wires are twisted tightly to grounding tab. Terminate this neutral wire in the concentric neutral compression connector.

Bundle both sets of concentric wires into a single conductor and jumper across the splice body.

Using the appropriate compression connector (user supplied), connect the concentric neutrals together.

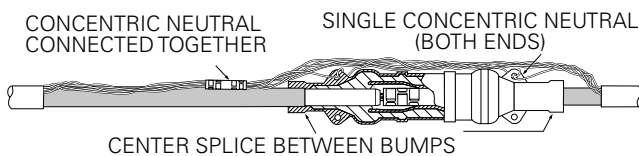

**Figure 6. Cutaway of installed splice.**

**Step 7**

Slide the re-jacketing sleeve into place so that it covers the entire area that was exposed when the cable jacket was originally removed. Install the re-jacketing sleeve per the manufacturer's recommended instructions.



This page is intentionally left blank.

This page is intentionally left blank.

This page is intentionally left blank.

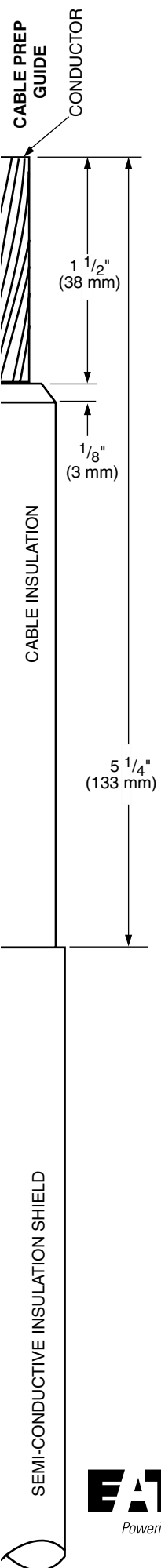

**Eaton**  
 1000 Eaton Boulevard  
 Cleveland, OH 44122  
 United States  
 Eaton.com

**Eaton's Cooper Power Systems  
 Division**  
 2300 Badger Drive  
 Waukesha, WI 53188  
 United States  
 Eaton.com/cooperpowerseries

© 2016 Eaton  
 All Rights Reserved  
 Printed in USA  
 Publication No. MN650006EN Rev 01  
 Supersedes S700152 Rev 00

Eaton is a registered trademark.

All trademarks are property  
 of their respective owners.

**EATON**  
 Powering Business Worldwide

For Eaton's Cooper Power series product  
 information call 1-877-277-4636 or visit:  
 www.eaton.com/cooperpowerseries.