

## 200 A 15/25 kV class deadbreak straight connector installation instructions

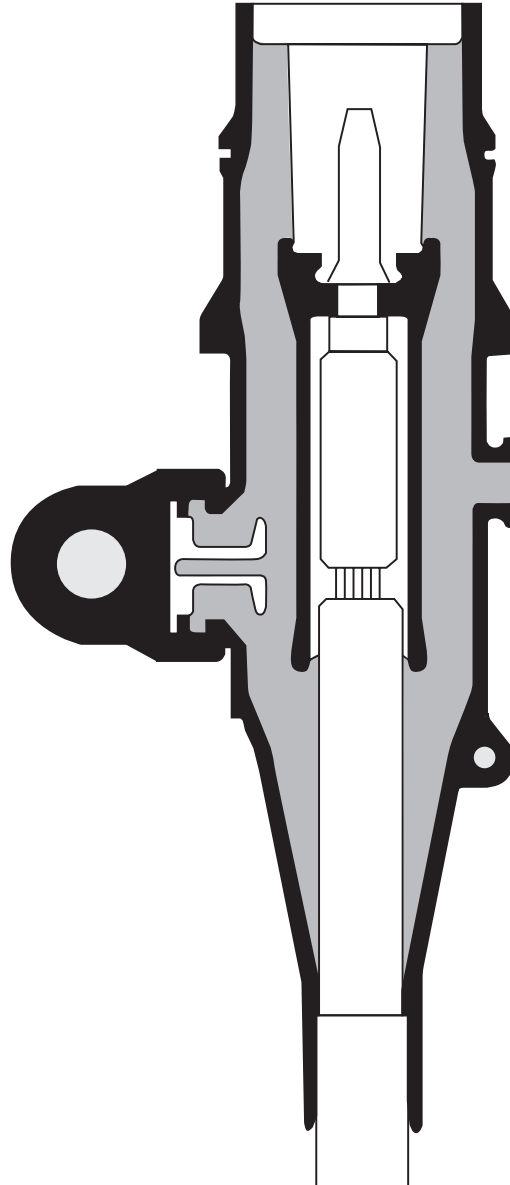

## **DISCLAIMER OF WARRANTIES AND LIMITATION OF LIABILITY**

The information, recommendations, descriptions and safety notations in this document are based on Eaton Corporation's ("Eaton") experience and judgment and may not cover all contingencies. If further information is required, an Eaton sales office should be consulted. Sale of the product shown in this literature is subject to the terms and conditions outlined in appropriate Eaton selling policies or other contractual agreement between Eaton and the purchaser.

THERE ARE NO UNDERSTANDINGS, AGREEMENTS, WARRANTIES, EXPRESSED OR IMPLIED, INCLUDING WARRANTIES OF FITNESS FOR A PARTICULAR PURPOSE OR MERCHANTABILITY, OTHER THAN THOSE SPECIFICALLY SET OUT IN ANY EXISTING CONTRACT BETWEEN THE PARTIES. ANY SUCH CONTRACT STATES THE ENTIRE OBLIGATION OF EATON. THE CONTENTS OF THIS DOCUMENT SHALL NOT BECOME PART OF OR MODIFY ANY CONTRACT BETWEEN THE PARTIES.

In no event will Eaton be responsible to the purchaser or user in contract, in tort (including negligence), strict liability or otherwise for any special, indirect, incidental or consequential damage or loss whatsoever, including but not limited to damage or loss of use of equipment, plant or power system, cost of capital, loss of power, additional expenses in the use of existing power facilities, or claims against the purchaser or user by its customers resulting from the use of the information, recommendations and descriptions contained herein. The information contained in this manual is subject to change without notice.

**Contents**

**DISCLAIMER OF WARRANTIES AND LIMITATION OF LIABILITY . . . . . I**

**SAFETY FOR LIFE . . . . . III**

**SAFETY INFORMATION . . . . . III**  
    Safety instructions . . . . . iii

**GENERAL . . . . . 1**

**INSTALLATION . . . . . 1**

**PREPARATION OF CONCENTRIC NEUTRAL CABLE . . . . . 2**

**STRAIGHT CONNECTOR AND COPPERTOP INSTALLATION . . . . . 3**



## Safety for life



Eaton's Cooper Power series products meet or exceed all applicable industry standards relating to product safety. We actively promote safe practices in the use and maintenance of our products through our service literature, instructional training programs, and the continuous efforts of all Eaton employees involved in product design, manufacture, marketing, and service.

We strongly urge that you always follow all locally approved safety procedures and safety instructions when working around high voltage lines and equipment, and support our "Safety For Life" mission.

## Safety information

The instructions in this manual are not intended as a substitute for proper training or adequate experience in the safe operation of the equipment described. Only competent technicians who are familiar with this equipment should install, operate, and service it.

A competent technician has these qualifications:

- Is thoroughly familiar with these instructions.
- Is trained in industry-accepted high and low-voltage safe operating practices and procedures.
- Is trained and authorized to energize, de-energize, clear, and ground power distribution equipment.
- Is trained in the care and use of protective equipment such as arc flash clothing, safety glasses, face shield, hard hat, rubber gloves, clampstick, hotstick, etc.

Following is important safety information. For safe installation and operation of this equipment, be sure to read and understand all cautions and warnings.

### Hazard Statement Definitions

This manual may contain four types of hazard statements:

#### DANGER

Indicates an imminently hazardous situation which, if not avoided, will result in death or serious injury.

#### WARNING

Indicates a potentially hazardous situation which, if not avoided, could result in death or serious injury.

#### CAUTION

Indicates a potentially hazardous situation which, if not avoided, may result in minor or moderate injury.

#### CAUTION

Indicates a potentially hazardous situation which, if not avoided, may result in equipment damage only.

### Safety instructions

Following are general caution and warning statements that apply to this equipment. Additional statements, related to specific tasks and procedures, are located throughout the manual.

#### DANGER

**Hazardous voltage. Contact with hazardous voltage will cause death or severe personal injury. Follow all locally approved safety procedures when working around high- and low-voltage lines and equipment.**

G103.3

#### WARNING

**Before installing, operating, maintaining, or testing this equipment, carefully read and understand the contents of this manual. Improper operation, handling or maintenance can result in death, severe personal injury, and equipment damage.**

G101.0

#### WARNING

**This equipment is not intended to protect human life. Follow all locally approved procedures and safety practices when installing or operating this equipment. Failure to comply can result in death, severe personal injury and equipment damage.**

G102.1

#### WARNING

**Power distribution and transmission equipment must be properly selected for the intended application. It must be installed and serviced by competent personnel who have been trained and understand proper safety procedures. These instructions are written for such personnel and are not a substitute for adequate training and experience in safety procedures. Failure to properly select, install or maintain power distribution and transmission equipment can result in death, severe personal injury, and equipment damage.**

G122.3

---

**⚠ WARNING**

---

**All associated apparatus must be de-energized during installation, operation and/or maintenance.**

**General**

The Eaton Cooper Power series Deadbreak Straight Connector is a fully-shielded and insulated plug-in termination for connecting underground cable to transformers, switching cabinets and junctions equipped with deadbreak bushings.

Wide cable ranges are sized to accept cables insulated at either 175 mil or 220 mil within a given conductor size. The wider cable ranges increase installation flexibility.

The Coppertop (bimetal) compression connector is a standard item to transition from the cable to the bushing contacts. An aluminum crimp barrel is inertia-welded to a copper lug. The aluminum barrel makes the connector easy to crimp and the copper lug ensures a reliable, tight, cool operating connection with the bushing contacts.

---

**⚠ CAUTION**

---

**The 200 A Deadbreak Straight Connector is designed to be operated in accordance with normal safe operating procedures. These instructions are not intended to supersede or replace existing safety and operating procedures. The straight connector should be installed and serviced only by personnel familiar with good safety practices and the handling of high-voltage electrical equipment.**

**Installation**

Cable stripping and scoring tools, available from various tool manufacturers, are recommended for use when installing deadbreak connectors. After preparing the cable, the connector housing is pushed onto the cable.

Complete straight connector kit includes:

- Connector Body with Test Point
- Coppertop Compression Connector
- Bail Assembly
- Silicone Lubricant
- Instruction Sheet

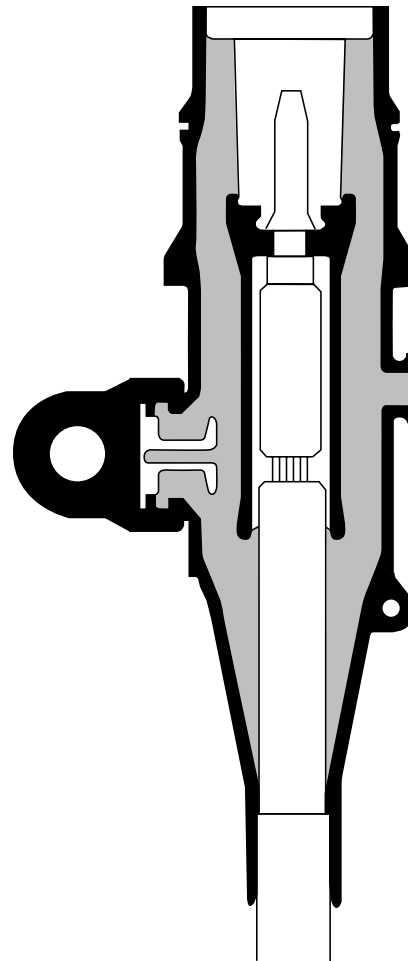

**Figure 1. 15/25 kV deadbreak straight connector**

Tools/Accessories needed:

- Tape Measure
- Wire Brush
- Knife
- Cable Stripping Tool
- Crimping Tool
- Cable Cleaner
- Cable Cutters
- Emery Cloth

These instructions do not claim to cover all details or variations in the equipment, procedure, or process described, nor to provide directions for meeting every contingency during installation, operation, or maintenance. When additional information is desired to satisfy a problem not covered sufficiently for the user's purpose, contact your Eaton representative.

## 200 A 15/25 kV class deadbreak straight connector installation instructions

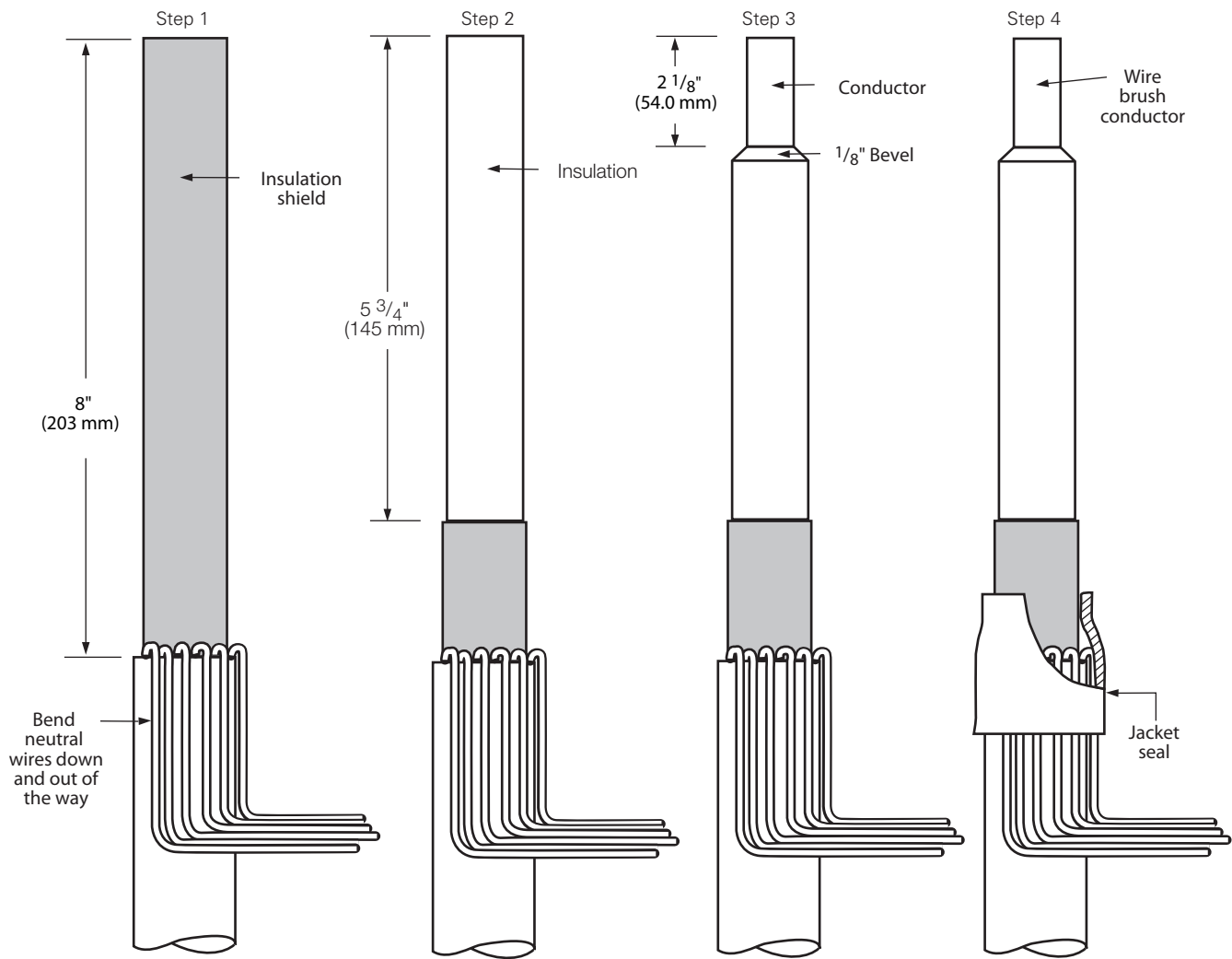

### Preparation of concentric neutral cable

#### Step 1

Measure down from top of the cable a minimum of 8".

Remove cable jacket (if jacketed cable is used) to expose neutral wires.

Unwind neutral wires.

**Note:** If an Eaton Cooper Power series jacket seal is used, follow instructions supplied with the jacket seal kit.

#### Step 2

Measure down from top of the cable 5 3/4".

Remove the insulation shield. Take care not to nick or gouge insulation.

#### Step 3

Measure down from the top of the cable 2 1/8".

Remove the insulation and conductor shield to expose the bare conductor. Take care not to nick the conductor.

Place a 1/8" bevel on the insulation to ease installation.

#### Step 4

If not already in place, apply a suitable jacket seal over the jacket and exposed neutral wires.

Proceed to Step 5.

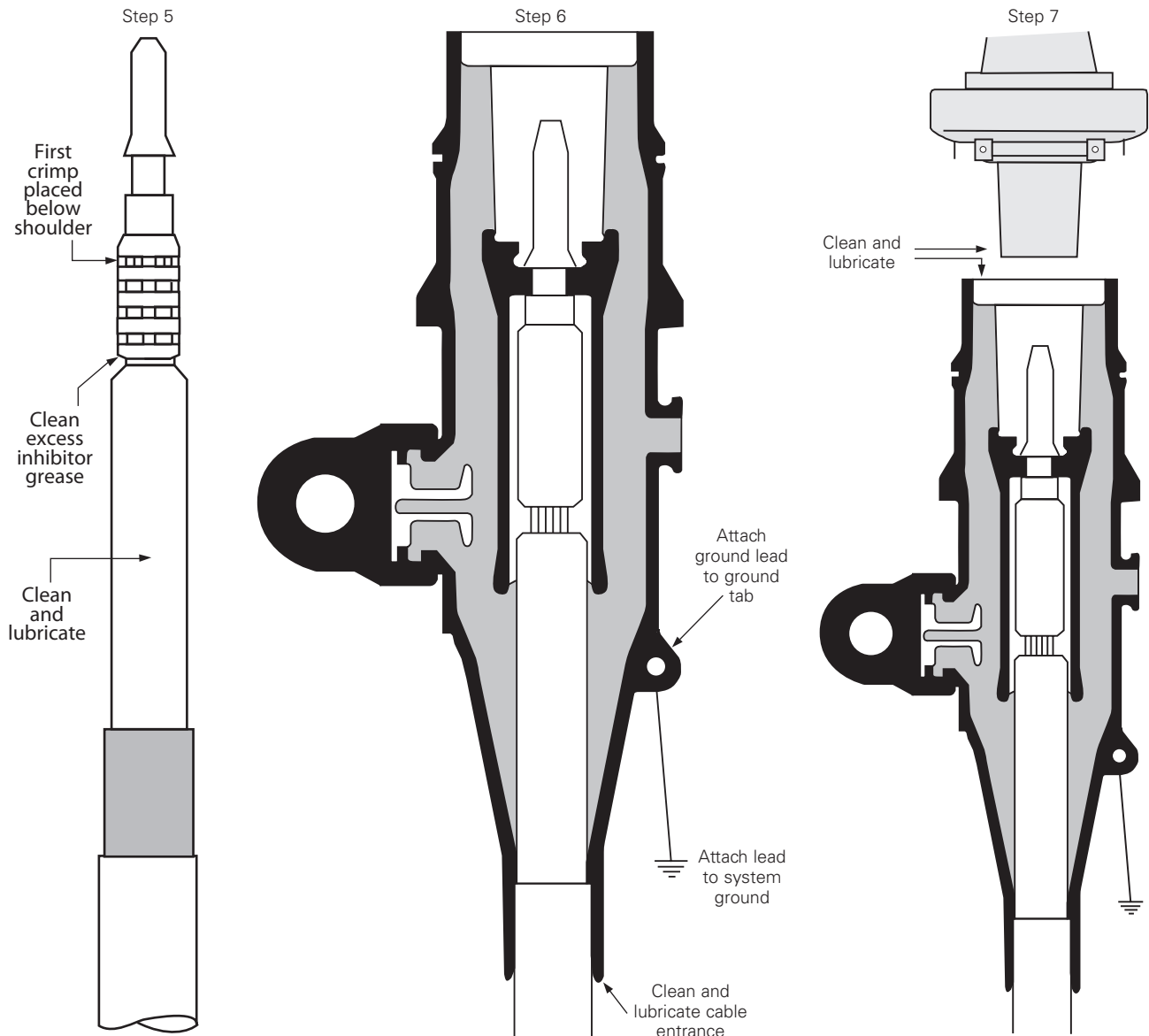

## Straight connector and coppertop installation

### Step 5

Clean the exposed conductor using a wire brush.

Place the Coppertop (bimetal) connector on the conductor.

Crimp the connector in place using a tool and die combination listed in Table 1. Start crimping just below the shoulder and rotate each successive crimp to prevent bowing. Do not overlap crimps. Place as many crimps on the connector as will fit.

### Step 6

Clean excess inhibitor grease from Coppertop connector by wiping toward the coppertop.

Clean insulation with a lint free cloth saturated with a cleaning solution. Wipe insulation toward insulation shield.

Apply a thin coating of grease to the insulation.

Clean and lubricate the cable entrance of the connector.

Place straight connector on cable. With a twisting motion, push connector onto cable until it snaps into position. Attach a ground lead to the grounding tab of the connector.

### Step 7

Clean the straight connector and bushing interfaces and apply a thin uniform layer of silicone lubricant to both interfaces. Push the connector onto the bushing until it is fully seated.

Insert the bail rods into the bushing tabs. Slide the bail plates around the connector and insert the threaded ends of the rods through the holes in the plates. Engage and tighten the knurled nuts.

# 200 A 15/25 kV class deadbreak straight connector installation instructions

**Table 1. Crimp chart**

Connector	5/8" Diameter					3/4" Diameter				
Conductor size	NO. 4 Thru 2/0 Stranded					3/0 - 4/0 Stranded				
	Tool	Y34	Y35 or Y39		MD6		Y34	Y35 or Y39		MD6
<b>Burndy</b>	Die	A243	U243	UBG	W243	WBG	U247	U247	U467	W247
		A25AR	U25ART	U687	BG NOSE	W687	A27AR	U27ART		
<b>Somerset (T and B)</b>	Tool	UT-3		UT-5		UT-15	UT-5		UT-15	
	Die	5/8"		TV		54 H	TV		66	
<b>Kearney</b>	Tool	0		H-1, H-2			0		H-1, H-2	
	Die	5/8" NOSE	9/16"	9/16"	572		737	747	737	747
<b>Alcoa</b>	Tool		12A					12A		
	Die		B24 EA					B39 EA		
<b>Anderson tool</b>			VC-5, VC-6					VC-5, VC-6		
<b>EEL – Reference</b>			8A					10A		

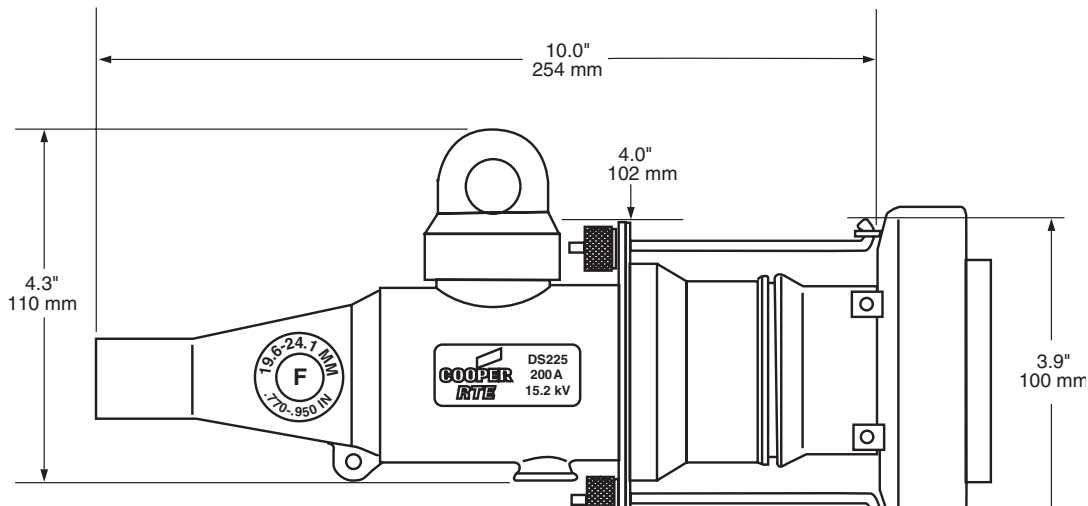

**Figure 2. DS225 deadbreak connector dimensional information**

**⚠ WARNING**

This is a Deadbreak Connector System. All associated apparatus must be de-energized before and during installation and/or operation.



This page intentionally left blank.

This page intentionally left blank.

This page intentionally left blank.



**Eaton**  
1000 Eaton Boulevard  
Cleveland, OH 44122  
United States  
Eaton.com

**Eaton's Power Systems Division**  
2300 Badger Drive  
Waukesha, WI 53188  
United States  
Eaton.com/cooperpowerseries

© 2017 Eaton  
All Rights Reserved  
Printed in USA  
Publication No. MN650043EN Rev. 00  
Supersedes 5000050922 Rev. 0  
February 2017

Eaton is a registered trademark.

All trademarks are property  
of their respective owners.

For Eaton's Cooper Power series product  
information  
call 1-877-277-4636 or visit:  
[www.eaton.com/cooperpowerseries](http://www.eaton.com/cooperpowerseries).