

200 A, 35 kV class loadbreak junction installation instructions

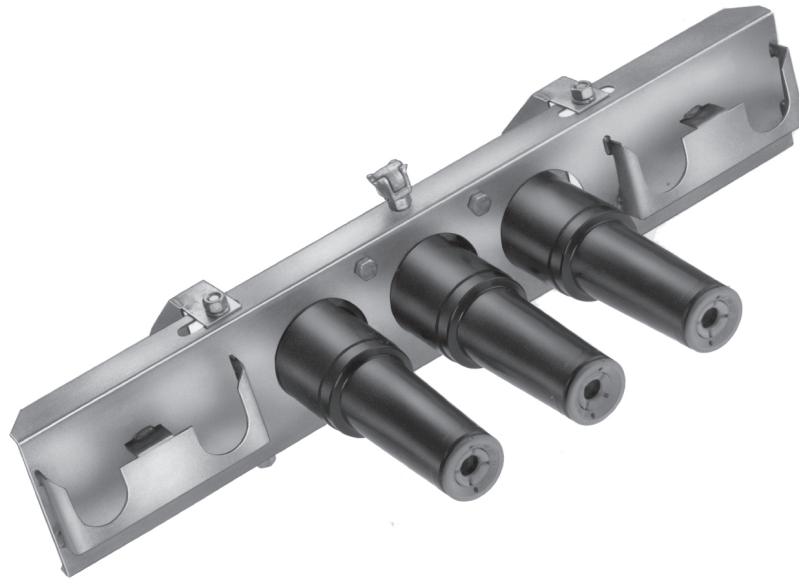

DISCLAIMER OF WARRANTIES AND LIMITATION OF LIABILITY

The information, recommendations, descriptions and safety notations in this document are based on Eaton Corporation's ("Eaton") experience and judgment and may not cover all contingencies. If further information is required, an Eaton sales office should be consulted. Sale of the product shown in this literature is subject to the terms and conditions outlined in appropriate Eaton selling policies or other contractual agreement between Eaton and the purchaser.

THERE ARE NO UNDERSTANDINGS, AGREEMENTS, WARRANTIES, EXPRESSED OR IMPLIED, INCLUDING WARRANTIES OF FITNESS FOR A PARTICULAR PURPOSE OR MERCHANTABILITY, OTHER THAN THOSE SPECIFICALLY SET OUT IN ANY EXISTING CONTRACT BETWEEN THE PARTIES. ANY SUCH CONTRACT STATES THE ENTIRE OBLIGATION OF EATON. THE CONTENTS OF THIS DOCUMENT SHALL NOT BECOME PART OF OR MODIFY ANY CONTRACT BETWEEN THE PARTIES.

In no event will Eaton be responsible to the purchaser or user in contract, in tort (including negligence), strict liability or otherwise for any special, indirect, incidental or consequential damage or loss whatsoever, including but not limited to damage or loss of use of equipment, plant or power system, cost of capital, loss of power, additional expenses in the use of existing power facilities, or claims against the purchaser or user by its customers resulting from the use of the information, recommendations and descriptions contained herein. The information contained in this manual is subject to change without notice.

Contents

DISCLAIMER OF WARRANTIES AND LIMITATION OF LIABILITY I

SAFETY FOR LIFE III

SAFETY INFORMATION III
 Safety instructions iii

PRODUCT INFORMATION 1
 Introduction 1
 Acceptance and initial inspection 1
 Handling and storage 1

EQUIPMENT REQUIRED 2
 200 A 35 kV Loadbreak junction only kit includes 2
 200 A 35 kV Loadbreak junction with stainless steel bracket kit includes 2
 200 A 35 kV Loadbreak junction with U-Straps 2

TOOLS REQUIRED 2

INSTALLATION INSTRUCTIONS 2
 Loadbreak junction with stainless steel bracket 2
 Loadbreak junction with U-Straps 4

OPERATING INSTRUCTIONS 5
 Loadmake operation 5
 Loadbreak operation 5

MOUNTING CONFIGURATIONS 6
 Drawings and dimensions 6



Safety for life



Eaton's Cooper Power series products meet or exceed all applicable industry standards relating to product safety. We actively promote safe practices in the use and maintenance of our products through our service literature, instructional training programs, and the continuous efforts of all Eaton employees involved in product design, manufacture, marketing, and service.

We strongly urge that you always follow all locally approved safety procedures and safety instructions when working around high voltage lines and equipment, and support our "Safety For Life" mission.

Safety information

The instructions in this manual are not intended as a substitute for proper training or adequate experience in the safe operation of the equipment described. Only competent technicians who are familiar with this equipment should install, operate, and service it.

A competent technician has these qualifications:

- Is thoroughly familiar with these instructions.
- Is trained in industry-accepted high and low-voltage safe operating practices and procedures.
- Is trained and authorized to energize, de-energize, clear, and ground power distribution equipment.
- Is trained in the care and use of protective equipment such as arc flash clothing, safety glasses, face shield, hard hat, rubber gloves, clampstick, hotstick, etc.

Following is important safety information. For safe installation and operation of this equipment, be sure to read and understand all cautions and warnings.

Hazard Statement Definitions

This manual may contain four types of hazard statements:

DANGER

Indicates an imminently hazardous situation which, if not avoided, will result in death or serious injury.

WARNING

Indicates a potentially hazardous situation which, if not avoided, could result in death or serious injury.

CAUTION

Indicates a potentially hazardous situation which, if not avoided, may result in minor or moderate injury.

CAUTION

Indicates a potentially hazardous situation which, if not avoided, may result in equipment damage only.

Safety instructions

Following are general caution and warning statements that apply to this equipment. Additional statements, related to specific tasks and procedures, are located throughout the manual.

DANGER

Hazardous voltage. Contact with hazardous voltage will cause death or severe personal injury. Follow all locally approved safety procedures when working around high- and low-voltage lines and equipment.

G103.3

WARNING

Before installing, operating, maintaining, or testing this equipment, carefully read and understand the contents of this manual. Improper operation, handling or maintenance can result in death, severe personal injury, and equipment damage.

G101.0

WARNING

This equipment is not intended to protect human life. Follow all locally approved procedures and safety practices when installing or operating this equipment. Failure to comply can result in death, severe personal injury and equipment damage.

G102.1

WARNING

Power distribution and transmission equipment must be properly selected for the intended application. It must be installed and serviced by competent personnel who have been trained and understand proper safety procedures. These instructions are written for such personnel and are not a substitute for adequate training and experience in safety procedures. Failure to properly select, install or maintain power distribution and transmission equipment can result in death, severe personal injury, and equipment damage.

G122.3

Product information

Introduction

The Eaton Cooper Power series 200 A, 35 kV Class Loadbreak Junction provides two, three or four 21.1/36.6 kV loadbreak interfaces that are internally bused together and meet all requirements of IEEE Std 386™ standard — Separable Insulated Connector Systems. Loadbreak junctions are used in pad-mounted apparatus, underground vaults, and other apparatus to sectionalize, establish loops, taps, or splices, and to facilitate apparatus changeouts.

WARNING

High voltage. All associated apparatus must be de-energized during any hands-on installation or maintenance. Failure to comply may result in death, severe personal injury and equipment damage.

CAUTION

High voltage. The 200 A Loadbreak Junction is designed to be operated in accordance with normal safe operating procedures. These instructions are not intended to supersede or replace existing safety and operating procedures. The loadbreak junction should be installed and serviced only by personnel familiar with good safety practices and the handling of high-voltage electrical equipment.

Read this manual first

Read and understand the contents of this manual and follow all locally approved procedures and safety practices before installing or operating this equipment.

Additional information

These instructions cannot cover all details or variations in the equipment, procedures, or process described nor provide directions for meeting every possible contingency during installation, operation, or maintenance. For additional information, contact your representative.

Acceptance and initial inspection

Each loadbreak junction is in good condition when accepted by the carrier for shipment. Upon receipt, inspect the shipping container for signs of damage. Unpack the loadbreak junction and inspect it thoroughly for damage incurred during shipment. If damage is discovered, file a claim with the carrier immediately.

Handling and storage

Be careful during handling and storage of the loadbreak junction to minimize the possibility of damage. If the loadbreak junction is to be stored for any length of time prior to installation, provide a clean, dry storage area.

Quality standards

ISO 9001 Certified Quality Management System

Equipment required

200 A loadbreak junction only kit includes

- Loadbreak Junction
- Instruction Sheet

200 A loadbreak junction with stainless steel bracket kit includes

- Loadbreak Junction with Frontplate (assembled). See Figure 2.
- Stainless Steel Adjustable Mounting Bracket and Assembly hardware. See Figure 3.
- Instruction Sheet

200 A loadbreak junction with U-straps

- Loadbreak Junction
- U-straps with Assembly Hardware
- Instruction Sheet

Tools required

- 5/16" Wrench

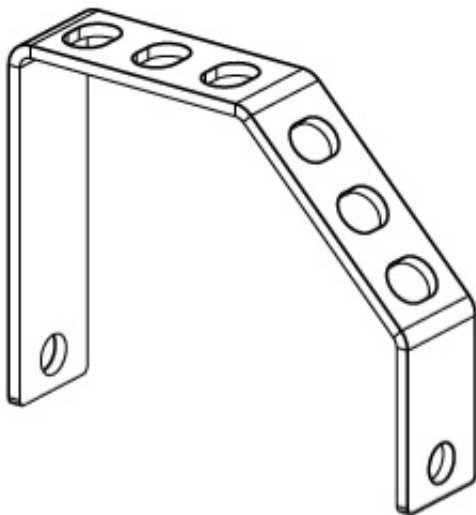

Figure 1. Pivot support leg

Installation instructions

Loadbreak junction with stainless steel bracket

Step 1

- Using supplied 5/16" hardware, attach adjustable mounting bracket to junction.

Note: Refer to mounting configurations and dimensions on page 6.

Step 2

- Adjustable mounting bracket can be mounted flat or at 45° tilt from mounting surface.
- Select desired mounting angle.

Step 3

- Using supplied 5/16" hardware, loosely attach adjustable mounting bracket to back of frontplate and place assembly against the mounting surface in desired orientation (Figure 2).
- Adjust the brackets for proper alignment and mark their location on the mounting surface.

Step 4

- After mounting location has been marked, detach adjustable mounting bracket from frontplate. Using 1/2" hardware (not supplied), mount bracket on mounting surface according to location marks made in Step 3.

200 A, 35 kV class loadbreak junction installation instructions

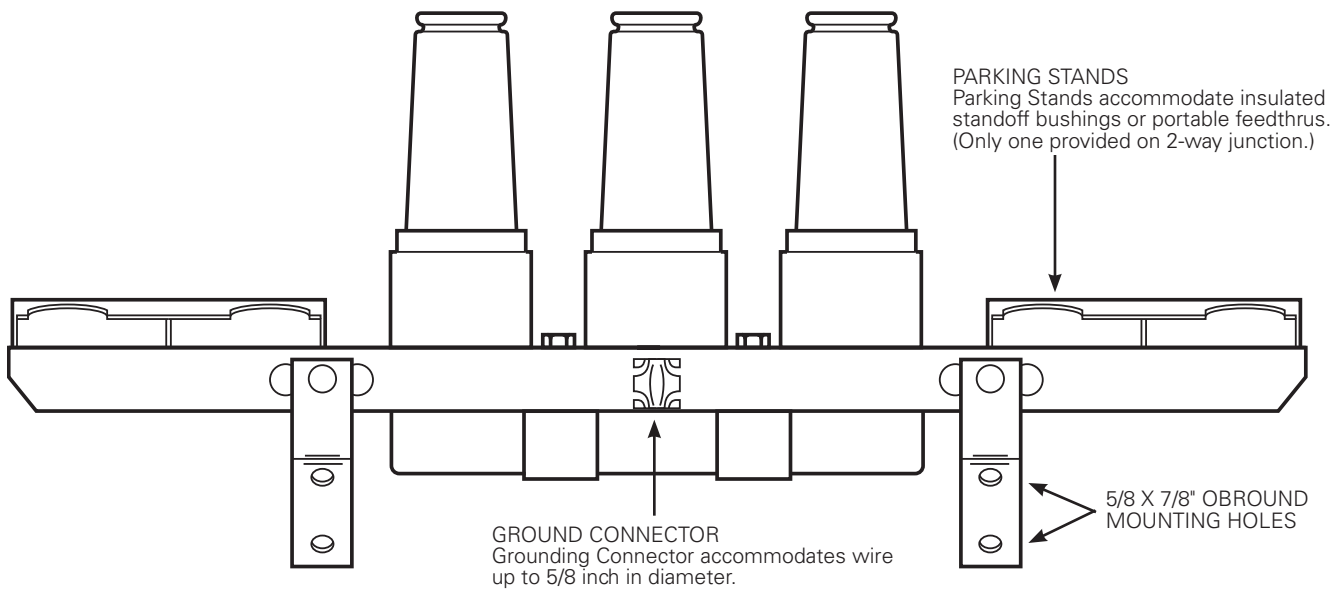

Figure 2. Pivot support/mounting feet assembled to frontplate

Step 5

- With adjustable mounting bracket secure, using supplied 5/16" hardware, mount frontplate with junction to bracket.

Step 6

- Using supplied drain wire clamps, connect bracket to ground. (Drain wire clamps accommodate two wires up to 1/0 stranded [5/8" dia.])

Step 7

- Remove protective shipping caps from junction interfaces. Clean and apply a thin layer of lubricant to the junction interfaces and mating accessory.

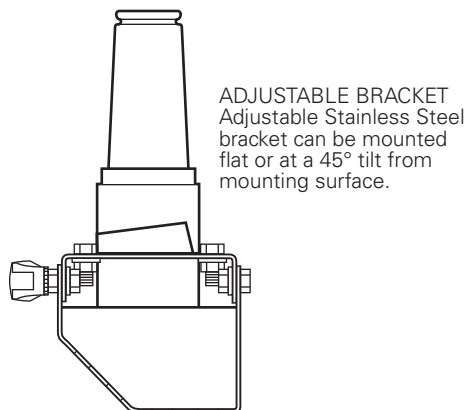

Figure 3. Adjustable bracket

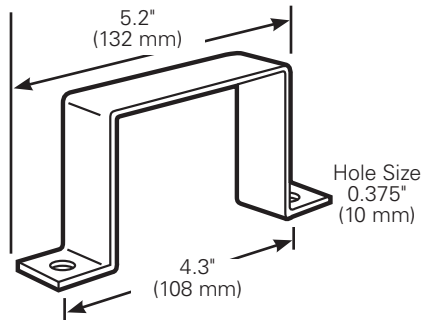

Figure 4. Stainless steel U-strap

Loadbreak junction with U-straps

Step 1

- Position loadbreak junction against mounting plate of apparatus and hold in place.

Step 2

- Place one supplied U-strap (Figure 4) between each post of the loadbreak junction and using the supplied 5/16" hardware attach U-straps to apparatus mounting plate, securing the loadbreak junction in place.

IMPORTANT

In applications where the junction is mounted without a stainless steel bracket, the mounting U-straps or the semi-conductive jacket of the junction must be grounded by an alternate means.

Step 3

- Tighten bolts securely.

Step 4

- Remove protective shipping caps from junction interfaces. Clean and apply a thin layer of lubricant to the junction interfaces and mating accessory.

WARNING

High voltage. All unused junction interfaces must be covered with a insulated protective cap before energization.

Do not use plastic shipping caps for this purpose.

Failure to comply may result in death, severe personal injury and equipment damage.

Operating instructions

Do not connect two different phases of a multiple-phase system. Before closing a single-phase loop, make certain both ends of the loop are the same phase.

Loadmake operation

- Area must be clear of obstructions or contaminations that would interfere with the operation of the loadbreak elbow.
- Securely fasten a clampstick to the pulling eye of the elbow.
- Place the loadbreak elbow over the bushing, inserting the white arc follower of the probe into the bushing approximately 2" until a slight resistance is felt. This will align and stabilize the elbow.
- Turn your back to the bushing and grasp the clampstick securely and obtain good footing. Slam the elbow onto the bushing with one quick and continuous motion.
- Turn around and apply a force to the clampstick to push the elbow onto the bushing. A popping or snapping sound is often heard when this operation is performed.
- To check that the elbow is properly latched apply a gentle pull force to the clampstick. When latched properly the elbow will not slide back off of the bushing.
- As a last operation, push on the clampstick to seat the elbow all the way onto the bushing again. This insures that the elbow is latched and was not dislodged during the latching check in previous step above.

Loadbreak operation

- Area must be clear of obstructions or contaminants that would interfere with this operation.
- Use clampstick to secure standoff insulator or portable feedthru in bracket. Ground devices to system ground per appropriate Installation Instructions. All associated apparatus must also be grounded.
- Secure elbow eye firmly onto clampstick and lock.
- Twist clampstick clockwise until the elbow rotates slightly on bushing — about 1/4" (7 mm). This action will break any surface friction between outer surface of bushing and inner surface of elbow.
- Withdraw elbow from bushing with a fast, firm, straight motion. Minimum amount of travel of elbow to break load is 9" (229 mm).
- Use clampstick to place elbow on lubricated standoff insulator or portable feedthru. (Follow loadmake instructions.)
- Place an insulated protective cap with ground wire attached to system ground on any exposed energized bushing using clampstick. Follow the same operating procedures as for the elbow as outlined above under Loadmake Operation.

CAUTION

The operator should always use personal protective equipment (insulated gloves, clampstick and eye protection) whenever operating the elbow. The operator should always be in the best possible operating position, providing firm footing and enabling a secure grasp of the clampstick, while maintaining positive control of the elbow before, during and immediately after operation. If there is any question regarding the operator's operating position, de-energize the elbow before operation. The operator should not be looking directly at the connector during the moment of circuit interruption or connection.

Mounting configurations

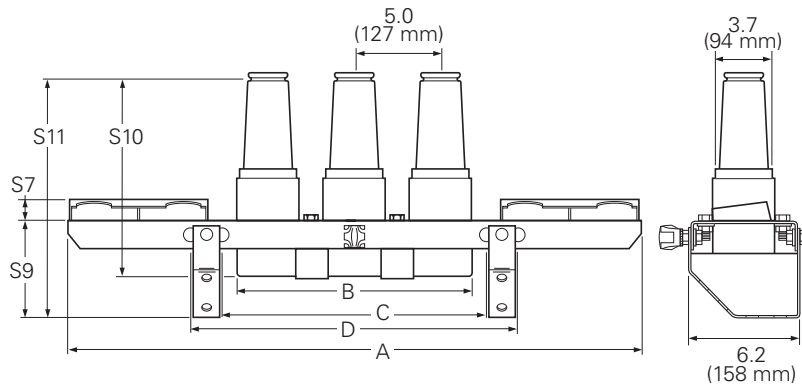

Table 1. 35 kV Dimensional information

Number of interfaces	Mounting dimensions in./mm			
	A	B	C	D
2	23.1	8.8	15.0	19.0
	(587)	(223)	(381)	(483)
3	33.3	13.8	15.0	19.0
	(846)	(350)	(381)	(483)
4	38.5	18.8	20.0	24.0
	(978)	(477)	(508)	(610)

S Dim.	in (mm)
S7	1.02 (26 mm)
S9	5.46 (139 mm)
S10	11.52 (293 mm)
S11	13.79 (350 mm)

Figure 5. Dimensional drawing shows mounting configurations

Note: Dimensions are approximate and for reference only.

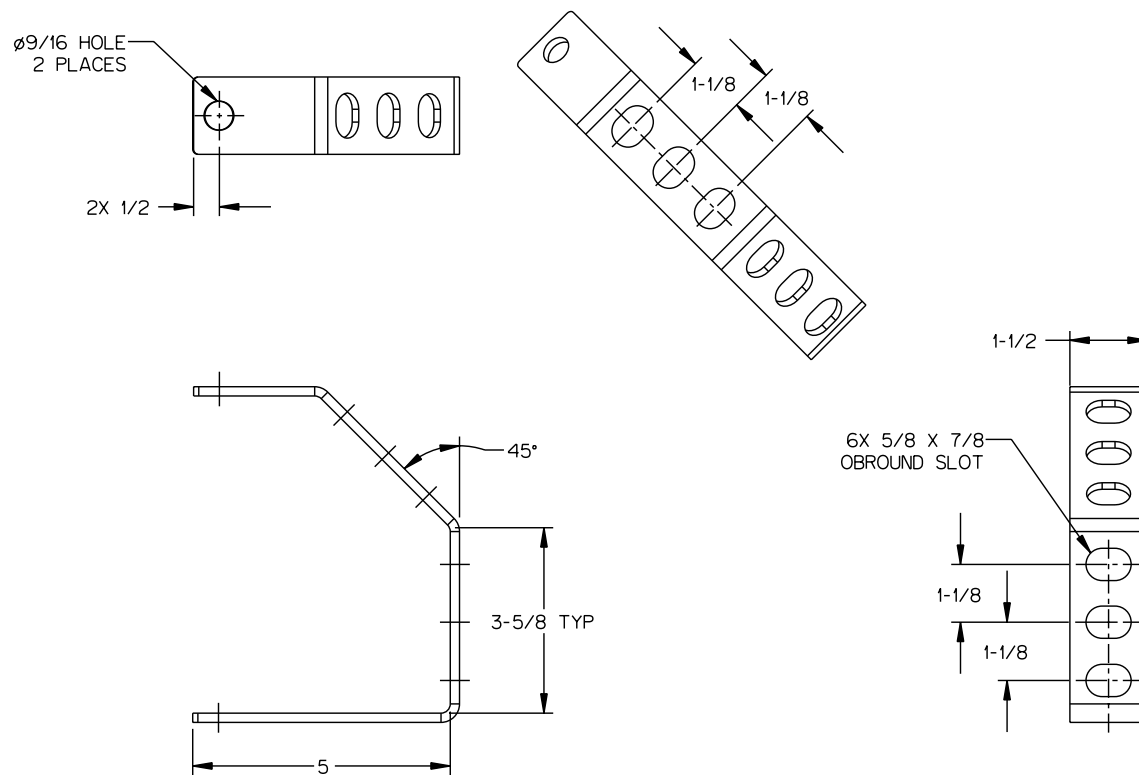

Figure 6. Mounting bracket

Note: Dimensions are approximate and for reference only.

This page intentionally left blank.



Eaton
1000 Eaton Boulevard
Cleveland, OH 44122
United States
Eaton.com

Eaton's Power Systems Division
2300 Badger Drive
Waukesha, WI 53188
United States
Eaton.com/cooperpowerseries

© 2017 Eaton
All Rights Reserved
Printed in USA
Publication No. MN650040EN
(Replaces S500511 Rev 2)
February 2017

Eaton is a registered trademark.

All trademarks are property
of their respective owners.

For Eaton's Cooper Power series product
information
call 1-877-277-4636 or visit:
www.eaton.com/cooperpowerseries.