

200 A 35 kV class "LE" series elbow installation instructions



DISCLAIMER OF WARRANTIES AND LIMITATION OF LIABILITY

The information, recommendations, descriptions and safety notations in this document are based on Eaton Corporation's ("Eaton") experience and judgment and may not cover all contingencies. If further information is required, an Eaton sales office should be consulted. Sale of the product shown in this literature is subject to the terms and conditions outlined in appropriate Eaton selling policies or other contractual agreement between Eaton and the purchaser.

THERE ARE NO UNDERSTANDINGS, AGREEMENTS, WARRANTIES, EXPRESSED OR IMPLIED, INCLUDING WARRANTIES OF FITNESS FOR A PARTICULAR PURPOSE OR MERCHANTABILITY, OTHER THAN THOSE SPECIFICALLY SET OUT IN ANY EXISTING CONTRACT BETWEEN THE PARTIES. ANY SUCH CONTRACT STATES THE ENTIRE OBLIGATION OF EATON. THE CONTENTS OF THIS DOCUMENT SHALL NOT BECOME PART OF OR MODIFY ANY CONTRACT BETWEEN THE PARTIES.

In no event will Eaton be responsible to the purchaser or user in contract, in tort (including negligence), strict liability or otherwise for any special, indirect, incidental or consequential damage or loss whatsoever, including but not limited to damage or loss of use of equipment, plant or power system, cost of capital, loss of power, additional expenses in the use of existing power facilities, or claims against the purchaser or user by its customers resulting from the use of the information, recommendations and descriptions contained herein. The information contained in this manual is subject to change without notice.

Contents

SAFETY INFORMATION

Safety Information	iv
--------------------------	----

PRODUCT INFORMATION

Introduction	1
Acceptance and Initial Inspection	1
Handling and Storage	1
Quality Standards	1

INSTALLATION INSTRUCTIONS

Installation Instructions	2
Preparation of Concentric Neutral Cable	3
Elbow and Loadbreak Probe Installation	4

OPERATING PROCEDURES

Loadmake Operation	5
Loadbreak Operation	5



Safety for life



Eaton meets or exceeds all applicable industry standards relating to product safety in its Cooper Power™ series products. We actively promote safe practices in the use and maintenance of our products through our service literature, instructional training programs, and the continuous efforts of all Eaton employees involved in product design, manufacture, marketing, and service.

We strongly urge that you always follow all locally approved safety procedures and safety instructions when working around high voltage lines and equipment, and support our “Safety For Life” mission.

Safety information

The instructions in this manual are not intended as a substitute for proper training or adequate experience in the safe operation of the equipment described. Only competent technicians who are familiar with this equipment should install, operate, and service it.

A competent technician has these qualifications:

- Is thoroughly familiar with these instructions.
- Is trained in industry-accepted high and low-voltage safe operating practices and procedures.
- Is trained and authorized to energize, de-energize, clear, and ground power distribution equipment.
- Is trained in the care and use of protective equipment such as arc flash clothing, safety glasses, face shield, hard hat, rubber gloves, clampstick, hotstick, etc.

Following is important safety information. For safe installation and operation of this equipment, be sure to read and understand all cautions and warnings.

Hazard Statement Definitions

This manual may contain four types of hazard statements:

DANGER

Indicates an imminently hazardous situation which, if not avoided, will result in death or serious injury.

WARNING

Indicates a potentially hazardous situation which, if not avoided, could result in death or serious injury.

CAUTION

Indicates a potentially hazardous situation which, if not avoided, may result in minor or moderate injury.

CAUTION: Indicates a potentially hazardous situation which, if not avoided, may result in equipment damage only.

Safety instructions

Following are general caution and warning statements that apply to this equipment. Additional statements, related to specific tasks and procedures, are located throughout the manual.

DANGER

Hazardous voltage. Contact with hazardous voltage will cause death or severe personal injury. Follow all locally approved safety procedures when working around high- and low-voltage lines and equipment.

G103.3

WARNING

Before installing, operating, maintaining, or testing this equipment, carefully read and understand the contents of this manual. Improper operation, handling or maintenance can result in death, severe personal injury, and equipment damage.

G101.0

WARNING

This equipment is not intended to protect human life. Follow all locally approved procedures and safety practices when installing or operating this equipment. Failure to comply can result in death, severe personal injury and equipment damage.

G102.1

WARNING

Power distribution and transmission equipment must be properly selected for the intended application. It must be installed and serviced by competent personnel who have been trained and understand proper safety procedures. These instructions are written for such personnel and are not a substitute for adequate training and experience in safety procedures. Failure to properly select, install or maintain power distribution and transmission equipment can result in death, severe personal injury, and equipment damage.

G122.3

⚠ WARNING

All associated apparatus must be de-energized during any hands-on installation or maintenance. Failure to comply may result in death, severe personal injury and equipment damage.

⚠ CAUTION

The 200 A loadbreak elbow connector is designed to be operated in accordance with normal safe operating procedures. These instructions are not intended to supersede or replace existing safety and operating procedures. The elbow connector should be installed and serviced only by personnel familiar with good safety practices and the handling of high-voltage electrical equipment.

⚠ CAUTION

Optional Capacitive Test Point Operating Instructions: Use only voltage indicating instruments specifically designed for test points. Use of conventional voltage sensing devices may provide false "No Voltage" indications.

The test point must be dry and free of contaminants when checking for voltage. After indication is taken: clean, dry, and lubricate the test point cap with silicone grease and assemble to the test point.

Always consider the termination to be energized until the test point "No Voltage" indication is confirmed by other means.

⚠ CAUTION

Elbows with tan cuffs (QuickMake probe) must be mated only with 21.1 kV 1Ø rated bushings (identified by tan nose pieces). Elbows with purple cuffs (3Ø probe) must be mated only with 21.1/36.6 kV 3Ø rated bushings (identified by purple nose pieces).

Product information

Introduction

Eaton's Cooper Power™ series loadbreak elbow connector is a fully-shielded and insulated plug-in termination for connecting underground cable to transformers, switching cabinets and junctions equipped with loadbreak bushings. The elbow connector and bushing insert comprise the essential components of all loadbreak connections.

Read this manual first

Read and understand the contents of this manual and follow all locally approved procedures and safety practices before installing or operating this equipment.

Additional information

These instructions cannot cover all details or variations in the equipment, procedures, or process described nor provide directions for meeting every possible contingency during installation, operation, or maintenance. For additional information, contact your Eaton representative.

Acceptance and initial inspection

Each loadbreak elbow is in good condition when accepted by the carrier for shipment. Upon receipt, inspect the shipping container for signs of damage. Unpack the elbow and inspect it thoroughly for damage incurred during shipment. If damage is discovered, file a claim with the carrier immediately.

Handling and storage

Be careful during handling and storage of the loadbreak elbow to minimize the possibility of damage. If the elbow is to be stored for any length of time prior to installation, provide a clean, dry storage area.

Standards

ISO 9001 Certified Quality Management System

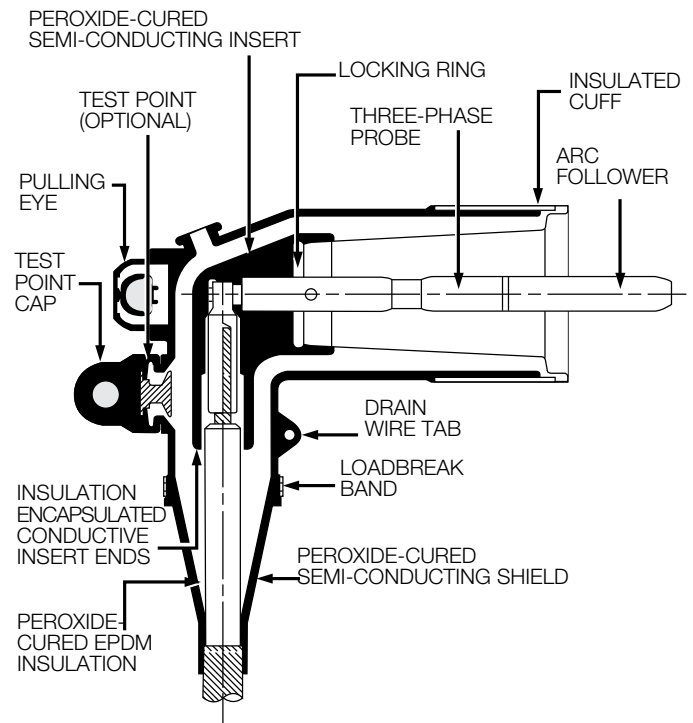

Figure 1. Line illustration of 200 A 35 kV Class elbow.

Installation instructions

Cable stripping and scoring tools, available from various tool manufacturers, are recommended for use when installing loadbreak elbows. After preparing the cable, the elbow housing is pushed onto the cable. The load-break probe is threaded into the coppertop connector using the supplied installation tool or an approved equivalent. Use a clampstick to perform loadmake and loadbreak operations. (See page 6 for operating instructions.)

Complete elbow kit includes:

- Elbow Body
- Coppertop Compression Connector
- Loadbreak Probe
- Probe Installation Tool
- Silicone Lubricant
- Instruction Sheet

Tools/Accessories needed:

- Tape Measure
- Wire Brush
- Knife
- Cable Stripping Tool
- Crimping Tool
- Cable Cleaner
- Cable Cutters
- Clampstick
- Personal Protection Equipment

For detailed instructions, please see pages 3-4.

Table 1. Crimp Chart												
Connector Size (AWG or kcmil)		Catalog Number	Nominal Barrel Diameter	Burndy®			Kearney™		Anderson® Tool	Thomas & Betts®		
Concentric or Compressed	Compact or Solid			Tool MD6	Tool Y35	Tool Y46**	Tool O	Tool H1, H2		Tool UT-3	Tool UT-5	Tool UT-15
				Die	Die		Die	Die		Die	Die	Die
2.88 in x 0.625 in. Connectors												
#6	#4	CC2C01T	5/8 in.	W-BG	U243	5/8 NOSE (5)	9/16 (5)	VC-5	5/8 (2)	TU	54H (2)	
#4	#3	CC2C02T		(2)	(2)			(4)				
#3	#2	CC2C03T		BG Nose	UBG			VC-6				
#2	#1	CC2C04T		(4)	(3)			(4)				
#1	1/0	CC2C05T										
1/0	2/0	CC2C06T		W243	U25ART							
2/0	3/0	CC2C07T		(3)	(2)							
2.88 in. x 0.780 in. Connectors												
3/0	4/0	CC2C08T	3/4 in.	W247	U27ART	737	737	VC-5	-	TU	66R (2)	
4/0	250	CC2C09T		(5)	(3)	(4)	(4)	(4)		(4)		
250 *	300	CC2C10T				747	747	VC-6		(4)		

* Compresses Stranding Only

**Burndy® Tool Y46 requires adapter P-U-ADP

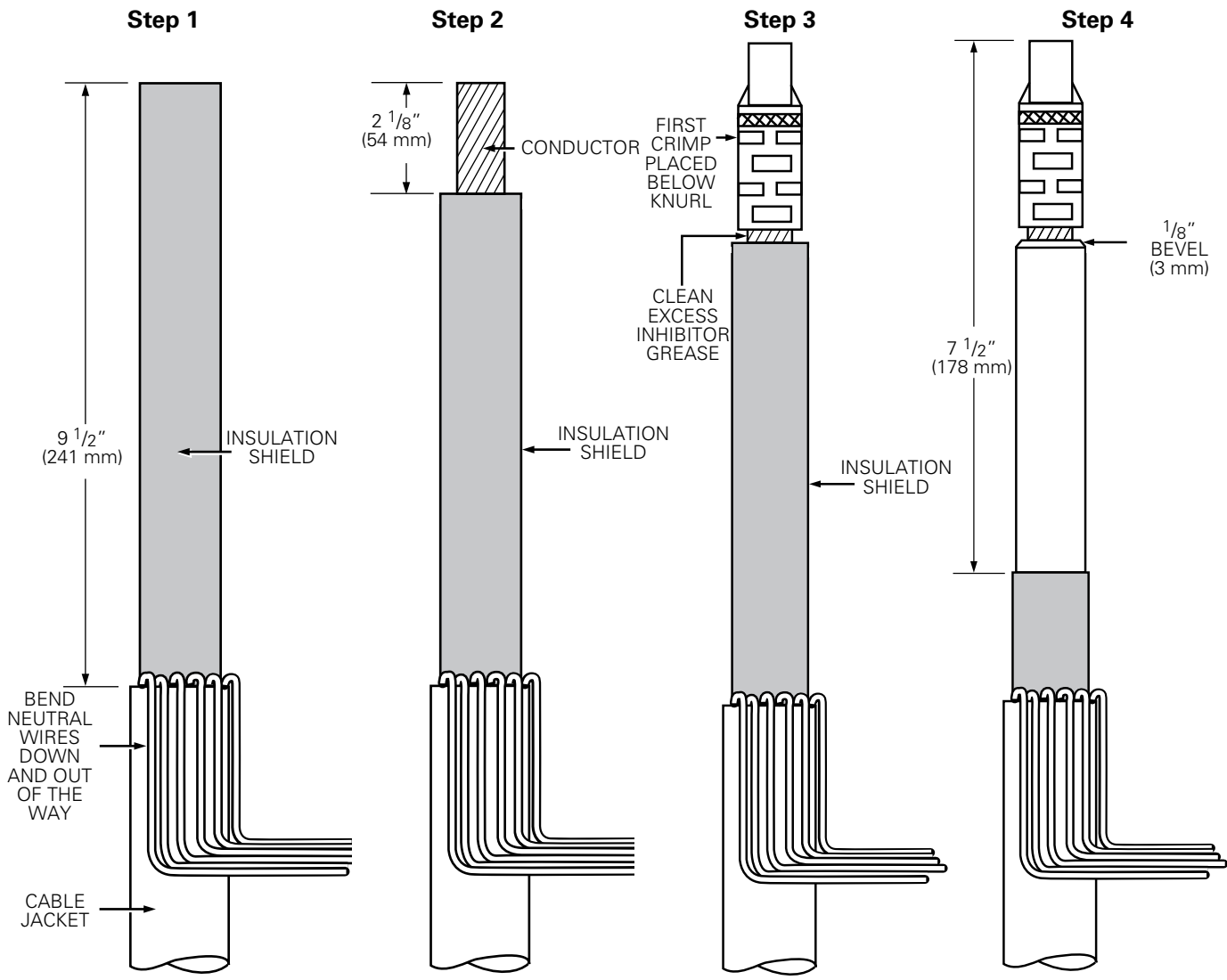

Cable preparation (concentric neutral)

Note: If concentric neutral cable is not being used, follow cable preparation directions in shield adapter kit.

Step 1

Measure down $9 \frac{1}{2}$ " from top of the cable.

Remove cable jacket (if jacketed cable is used) to expose neutral wires.

Unwind neutral wires.

Step 2

Measure down from the top of the cable $2 \frac{1}{8}$ ".

Remove the insulation and conductor shield to expose the bare conductor. Take care not to nick the conductor.

Step 3

Clean the exposed conductor using a wire brush.

Note: The probe (male contact) should be preassembled into the threads of the compression connector prior to crimping to ensure proper thread engagement.

Place the coppertop (bimetal) connector on the conductor. Make sure the threaded hole in connector faces the apparatus bushing.

Crimp the connector in place using a tool and die combination listed in Table 1 on page 3. Start crimping just below the knurled line and rotate each successive crimp to prevent bowing. Do not overlap crimps. Place as many crimps on the connector as will fit. Smooth any sharp edges on the crimp connector surface.

Clean excess inhibitor grease from coppertop connector by wiping toward threaded eye.

Step 4

Measure down from the top of the connector $7 \frac{1}{2}$ ".

Remove the insulation shield. Take care not to nick or gouge insulation. Place a $\frac{1}{8}$ " bevel on the insulation to ease elbow installation.

Step 5

Apply a suitable jacket seal over the jacket and exposed neutral wires.

If an Eaton jacket seal is used, follow instructions supplied with the jacket seal kit.

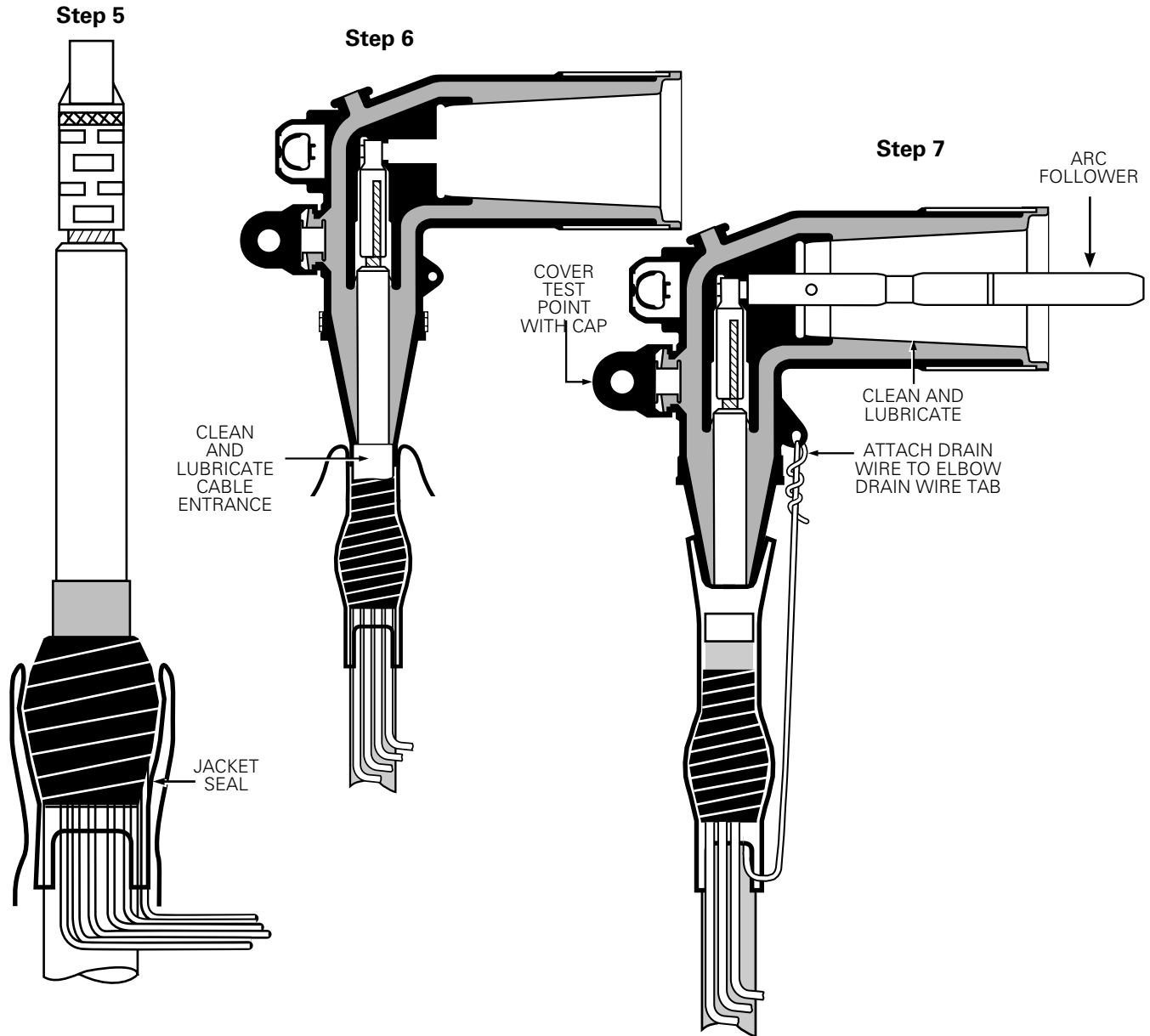

Elbow and loadbreak probe installation

Step 6

Clean insulation with a lint free cloth saturated with a cleaning solution. Wipe insulation toward insulation shield.

Apply a thin coating of supplied silicone lubricant to the insulation.

Clean and lubricate the cable entrance of the elbow.

Place elbow on cable. With a twisting motion, push elbow onto cable until threaded eye of coppertop connector is aligned with the elbow.

Step 7

By hand, thread loadbreak probe into threaded eye of coppertop connector.

When tight, use the provided installation tool to properly torque the loadbreak probe. Proper torque is applied when the tool achieves a 180° permanent set.

Note: If a different installation tool is used it must apply a torque of 100 to 120 in-lb (11.0-13.5 Nm).

Clean and lubricate bushing and elbow interface areas with a thin even coating of the silicone lubricant provided.

Attach a drain wire lead to the drain wire eye of the elbow.

To aid in the installation of the elbow onto the bushing, lightly lubricate the white arc follower on the end of the probe with a thin even coating of the silicone lubricant provided.

Operating instructions

Loadmake operation

- Area must be clear of obstructions or contaminations that would interfere with the operation of the loadbreak elbow.
- Securely fasten a clampstick to the pulling eye of the elbow.
- Place the loadbreak elbow over the bushing, inserting the white arc follower of the probe into the bushing approximately 2" until a slight resistance is felt. This will align and stabilize the elbow.
- Turn your back to the bushing and grasp the clampstick securely and obtain good footing. Slam the elbow onto the bushing with one quick and continuous motion.
- Turn around and apply a force to the clampstick to push the elbow onto the bushing. A popping or snapping sound is often heard when this operation is performed.
- To check that the elbow is properly latched apply a gentle pull force to the clampstick. When latched properly the elbow will not slide back off of the bushing.
- As a last operation, push on the clampstick to seat the elbow all the way onto the bushing again. This insures that the elbow is latched and was not dislodged during the latching check in previous step above.

Loadbreak operation

- Area must be clear of obstructions or contaminants that would interfere with this operation.
- Use clampstick to secure standoff insulator or portable feedthru in bracket. Ground devices to system ground per appropriate Installation Instructions. All associated apparatus must also be grounded.
- Secure elbow eye firmly onto clampstick and lock.
- Twist clampstick clockwise until the elbow rotates slightly on bushing—about 1/4" (7 mm). This action will break any surface friction between outer surface of bushing and inner surface of elbow.
- Withdraw elbow from bushing with a fast, firm, straight motion. Minimum amount of travel of elbow to break load is 9" (229 mm).
- Use clampstick to place elbow on lubricated standoff insulator or portable feedthru. (Follow loadmake instructions.)
- Place an insulated protective cap with ground wire attached to system ground on any exposed energized bushing using clampstick. Follow the same operating procedures as for the elbow as outlined above under Loadmake Operation.



CAUTION

The operator should always use personal protective equipment (insulated gloves, clampstick and eye protection) whenever operating the elbow. The operator should always be in the best possible operating position, providing firm footing and enabling a secure grasp of the clampstick, while maintaining positive control of the elbow before, during and immediately after operation. If there is any question regarding the operator's operating position, de-energize the elbow before operation. The operator should not be looking directly at the connector during the moment of circuit interruption or connection.

This page intentionally left blank.

This page intentionally left blank.

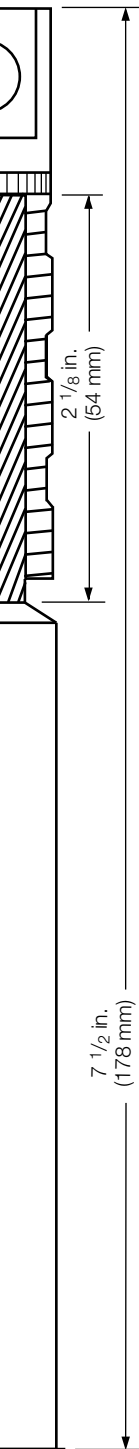

Eaton
 1000 Eaton Boulevard
 Cleveland, OH 44122
 United States
 Eaton.com

**Eaton's Cooper Power Systems
 Division**
 2300 Badger Drive
 Waukesha, WI 53188
 United States
 Eaton.com/cooperpowerseries

© 2015 Eaton
 All Rights Reserved
 Printed in USA
 Publication No. MN650010EN, Rev. 0
 Supersedes S500411Rev. 1

Eaton, Cooper Power, and Kearney are valuable trademarks of Eaton in the U.S. and other countries. You are not permitted to use the trademarks without the prior written consent of Eaton. Burndy® is a registered trademark of FCI. Thomas & Betts® is a registered trademark of Thomas and Betts. ACA Conductor Accessories is a division of AFL Telecommunications LLC. Anderson® is a registered trademark of Hubbell Power Systems.

For Eaton's Cooper Power series "LE" elbow product information call 1-877-277-4636 or visit: www.eaton.com/cooperpowerseries.