

200 A 35 kV class insulated standoff bushing



General

Eaton's Cooper Power™ series 200 A, 35 kV insulated standoff bushing meets the full requirements of IEEE Std 386™-2006 standard, Separable Insulated Connector Systems, and provides a single loadbreak interface made of high quality peroxide cured insulating EPDM rubber. It is used to isolate and sectionalize energized cable in pad-mounted cabinets, underground vaults, and other apparatus. Temporary or permanent parking of energized IEEE Std 386™-2006 standard loadbreak elbow connectors is simplified with use of the insulated standoff bushing. Dual colored (tan and purple) nosepiece designated application with both single-phase (21.1 kV) and (21.1/36.6 kV) rated 35 kV Class 200 A large interface loadbreak elbow connectors.

The insulated standoff bushing is designed to be installed in the parking stand mounted on a transformer or other apparatus. A grounding lug is provided on the standoff bushing bracket for attachment of a drain wire to ensure deadfront construction. When mated with a comparably rated product, the insulated standoff bushing provides a fully-shielded, submersible, separable connector for energized operation.

The standard insulated standoff bushing has a stainless steel eyebolt with a brass pressure foot. The molded EPDM rubber body is bolted to a stainless steel base bracket using a galvanized steel holddown ring.

Installation

No special tools are required. A clampstick tool is used to place the standoff bushing in the parking stand on the front plate of the apparatus. Refer to *Service Information S500-22-1, 200 A 15, 25, and 35 kV Class Insulated Standoff Bushing Installation Instructions* for details.

Production tests

Tests are conducted in accordance with IEEE Std 386™-2006 standard.

- AC 60 Hz 1 Minute Withstand
 - 50 kV
- Minimum Corona Voltage Level
 - 26 kV

Tests are conducted in accordance with Eaton requirements.

- Physical Inspection
- Periodic Dissection
- Periodic X-Ray Analys

Table 1. Voltage Ratings and Characteristics

Description	kV
Standard Voltage Class	35
Maximum Rating Phase-to-Ground	21.1
AC 60 Hz 1 Minute Withstand	50
DC 15 Minute Withstand	103
BIL and Full Wave Crest	150
Minimum Corona Voltage Level	26

Voltage ratings and characteristics are in accordance with IEEE Std 386™-2006 standard..

Ordering information

To order the 35 kV Class Insulated Standoff Bushing Kit, refer to Table 2.

Table 2. Standoff Bushing Kit

Description	Catalog Number
Standoff Bushing with Standard Bracket	ISB235

Each kit contains:

- Insulated Standoff Bushing with Bracket
- Shipping Cap (not for energized operation)
- Installation Instruction Sheet

Features and detailed description

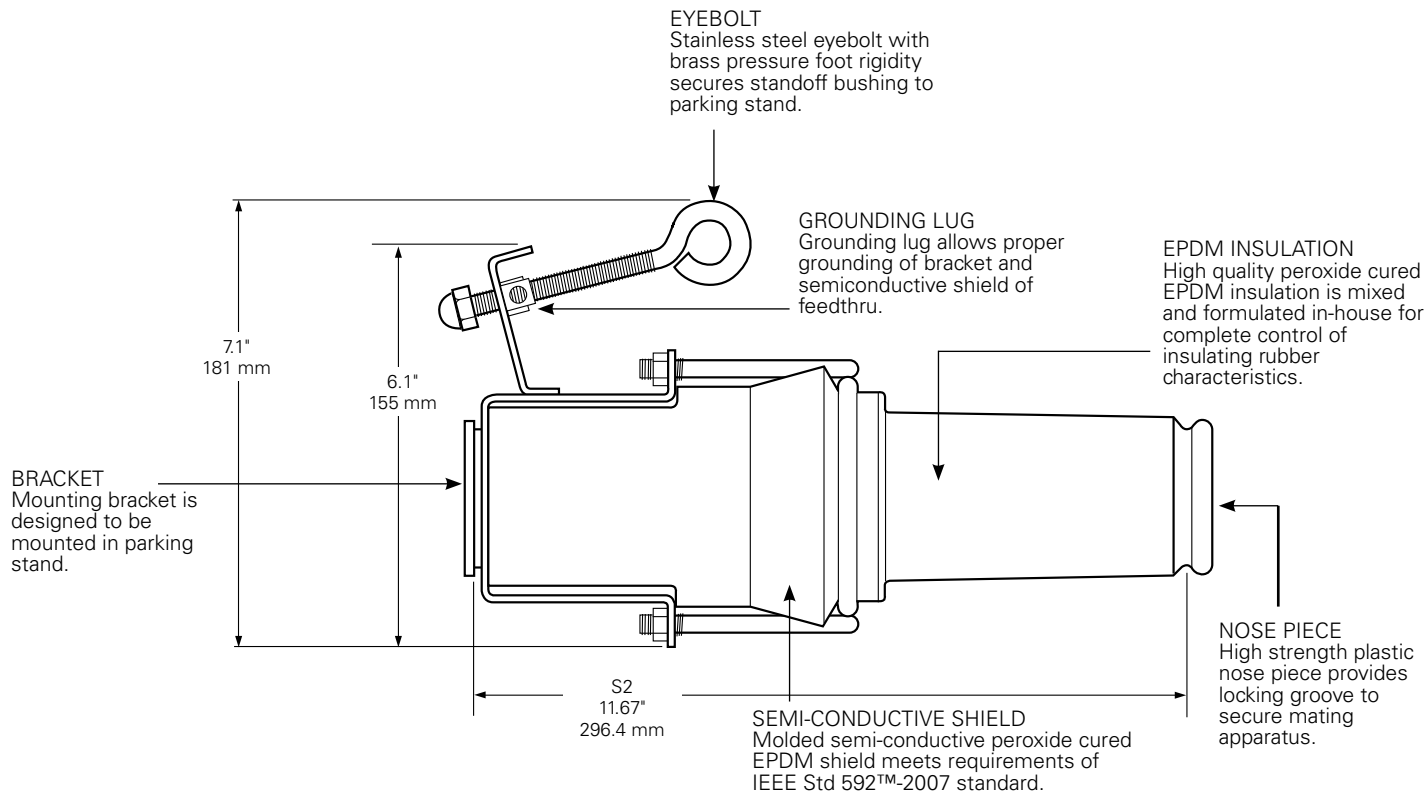

Figure 1. Insulated standoff bushing profile and stacking dimensions.

Note: Dimensions given are for reference only.

Eaton
1000 Eaton Boulevard
Cleveland, OH 44122
United States
Eaton.com

Eaton's Cooper Power Systems Division
2300 Badger Drive
Waukesha, WI 53188
United States
Eaton.com/cooperpowerseries

© 2015 Eaton
All Rights Reserved
Printed in USA
Publication No. CA650088EN

Eaton is a registered trademark.
All other trademarks are property
of their respective owners.

For Eaton's Cooper Power series product information call 1-877-277-4636 or visit:
www.eaton.com/cooperpowerseries.